

DISPLAY THIS CARD ON PRINCIPAL FRONTAGE OF WORK

CITY OF PORTLAND

Please Read Application And Notes, If Any, Attached

SECTION

PERMIT

Permit Number: 051161

PERMIT ISSUED

OCT 18 2005

CITY OF PORTLAND

This is to certify that Lacasse David R/Todd Ashfo

has permission to Extend rooftop deck in comm space

AT 72 High St

039 G010E02

provided that the person or persons, firm or corporation accepting this permit shall comply with all of the provisions of the Statutes of Maine and of the ordinances of the City of Portland regulating the construction, maintenance and use of buildings and structures, and of the application on file in this department.

Apply to Public Works for street line and grade if nature of work requires such information.

Notification of inspection must be given and work in permit in progress before this building or part thereof is leased or closed-in. FOUR HOUR NOTICE IS REQUIRED.

A certificate of occupancy must be procured by owner before this building or part thereof is occupied.

OTHER REQUIRED APPROVALS

Fire Dept. _____
Health Dept. _____
Appeal Board _____
Other _____
Department Name

Deanne Banks 10/18/05
Director - Building & Inspection Services

PENALTY FOR REMOVING THIS CARD

City of Portland, Maine - Building or Use Permit Application

389 Congress Street, 04101 Tel: (207) 874-8703, Fax: (207) 874-8716

PERMIT ISSUED

Permit No: 05-1161	Issue Date: OCT 18 2005	CBL: 039 G010E02
-----------------------	----------------------------	---------------------

Location of Construction: 72 High St	Owner Name: Lacasse David R	Owner Address: 80 High St #1	Phone:
Business Name:	Contractor Name: Todd Ashford	Contractor Address: Portland	Phone:
Lessee/Buyer's Name	Phone:	Permit Type: Alterations - Multi Family	Zone: R6

Past Use: Condo's	Proposed Use: Condo's/ Extend rooftop deck in common space	Permit Fee: \$39.00	Cost of Work: \$1,925.00	CEO District: 2
Proposed Project Description: 72-74 High St - five (5) d.u. legal use: 78-80 High St - five (5) d.u., 124 Pleasant St - seven (7) d.u. Extend rooftop deck in common space		FIRE DEPT: <input type="checkbox"/> Approved <input type="checkbox"/> Denied INSPECTION: Use Group: R2 Type: SB IRL-2003 Signature: [Signature] Date: 10/18/05	PEDESTRIAN ACTIVITIES DISTRICT (P.A.D.) Action: <input type="checkbox"/> Approved <input type="checkbox"/> Approved w/Conditions <input type="checkbox"/> Denied Signature: _____ Date: _____	

Permit Taken By: Idobson	Date Applied For: 08/12/2005	Zoning Approval
-----------------------------	---------------------------------	------------------------

1. This permit application does not preclude the Applicant(s) from meeting applicable State and Federal Rules. 2. Building permits do not include plumbing, septic or electrical work. 3. Building permits are void if work is not started within six (6) months of the date of issuance. False information may invalidate a building permit and stop all work..	Special Zone or Reviews <input type="checkbox"/> Shoreland <input type="checkbox"/> Wetland <input type="checkbox"/> Flood Zone <input type="checkbox"/> Subdivision <input type="checkbox"/> Site Plan Maj <input type="checkbox"/> Minor <input type="checkbox"/> MM <input type="checkbox"/> Denied Date: 9/19/05	Zoning Appeal <input type="checkbox"/> Variance <input type="checkbox"/> Miscellaneous <input type="checkbox"/> Conditional Use <input type="checkbox"/> Interpretation <input type="checkbox"/> Approved <input type="checkbox"/> Denied Date:	Historic Preservation <input type="checkbox"/> Not in District or Landmark <input type="checkbox"/> Does Not Require Review <input type="checkbox"/> Requires Review <input checked="" type="checkbox"/> Approved <input type="checkbox"/> Approved w/Conditions <input type="checkbox"/> Denied to D.A. Date: D. Anderson 9/28/05
--	---	--	--

CERTIFICATION

I hereby certify that I am the owner of record of the named property, or that the proposed work is authorized by the owner of record and that I have been authorized by the owner to make this application as his authorized agent and I agree to conform to all applicable laws of this jurisdiction. In addition, if a permit for work described in the application is issued, I certify that the code official's authorized representative shall have the authority to enter all areas covered by such permit at any reasonable hour to enforce the provision of the code(s) applicable to such permit.

SIGNATURE OF APPLICANT	ADDRESS	DATE	PHONE
RESPONSIBLE PERSON IN CHARGE OF WORK, TITLE		DATE	PHONE

City of Portland, Maine - Building or Use Permit

389 Congress Street, 04101 Tel: (207) 874-8703, Fax: (207) 874-8716

Permit No: 05-1161	Date Applied For: 08/12/2005	CBL: 039 G010E02
------------------------------	--	----------------------------

Location of Construction: 72 High St	Owner Name: Lacasse David R	Owner Address: 80 High St #1	Phone:
Business Name:	Contractor Name: Todd Ashford	Contractor Address: Portland	Phone:
Lessee/Buyer's Name	Phone:	Permit Type: Alterations - Multi Family	

Condo's/ Extend rooftop deck in common space - over existing flat roof	Extend rooftop deck in common space
--	-------------------------------------

Dept: Historical **Status:** Approved **Reviewer:** Deborah Andrews **Approval Date:** 09/28/2005
Note: **Ok to Issue:**
1) * Not visible from the street

Dept: Zoning **Status:** Approved with Conditions **Reviewer:** Marge Schmuckal **Approval Date:** 09/09/2005
Note: apparently condoized prior to the condominium conversion section of the ordinance was enacted. **Ok to Issue:**
1) This is NOT an approval for an additional dwelling unit. You SHALL NOT add any additional kitchen equipment including, but not limited to items such as stoves, microwaves, refrigerators, or kitchen sinks, etc. Without special approvals.
2) ANY exterior work requires a separate review and approval thru Historic Preservation. This property is located within a Historic District.
3) This permit is being approved on the basis of plans submitted. Any deviations shall require a separate approval before starting that work.
4) This entire property shall remain a seventeen (17) family dwelling as denoted. Any change of use shall require a separate permit application for review and approval. 72-74 High St = five (5) dwelling units. 78-80 High St = five (5) d.u. 124 Pleasant St = seven (7) d.u.

Dept: Building **Status:** Approved with Conditions **Reviewer:** Jeanine Bourke **Approval Date:** 10/18/2005
Note: 10/12/05 spoke to Todd A. About construction details as noted on plans. Also left vm w/owners about vent pipe. **Ok to Issue:**
10/18 David L. Called to say vent pipe was re-routed, ok to issue
1) Permit approved based on the plans submitted and reviewed w/owner/contractor, with additional information as agreed on and as noted on plans.

All Purpose Building Permit Application

If you or the property owner owes real estate or personal property taxes or user charges on any property Within the City, payment arrangements must be made before permits of any kind are accepted.

Location/Address of Construction: <u>80 High St (Back)</u>		
Total Square Footage of Proposed Structure <u>86 Sq Ft</u>		Square Footage of Lot
Tax Assessor's Chart, Block & Lot Chart# <u>39</u> Block# <u>G 10 E 2</u> Lot#	Owner: <u>David + Pandora LaCase</u>	Telephone: <u>774-2695</u>
Lessee/Buyer's Name (If Applicable)	Applicant name, address & telephone: <u>David LaCase</u> <u>80 High St #1</u> <u>774-2695</u>	cost Of Work: \$ <u>1,935</u> Fee: \$
<u>Space, Porch + 100' Top</u>		
If the location is currently vacant, what was prior use: _____		
Approximately how long has it been vacant: _____		
Proposed use: <u>Extension to walkway for units 78 + 80 #1</u>		
Project description: <u>Back entrance</u>		
Contractor's name, address & telephone: <u>Todd Westford 756-3294</u>		
Who should we contact when the permit is ready: <u>Pandora + David LaCase</u>		
Mailing address:		
We will contact you by phone when the permit is ready. You must come in and pick up the permit and review the requirements before starting any work, with a Plan Reviewer. A stop work order will be issued and a \$100.00 fee if any work starts before the permit is picked up.		

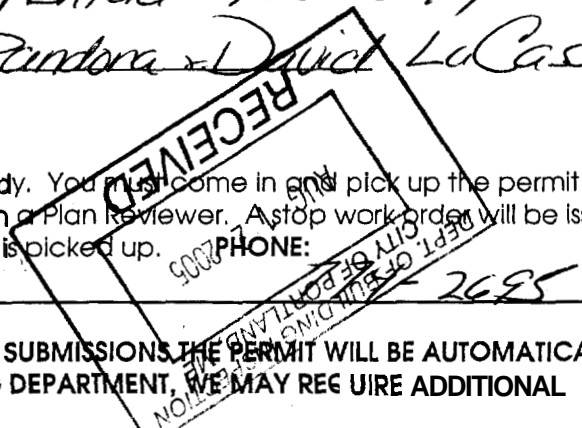

IF THE REQUIRED INFORMATION IS NOT INCLUDED IN THE SUBMISSIONS, THE PERMIT WILL BE AUTOMATICALLY DENIED AT THE DISCRETION OF THE BUILDING/PLANNING DEPARTMENT. WE MAY REQUIRE ADDITIONAL INFORMATION IN ORDER TO APPROVE THIS PERMIT.

I hereby certify that I am the Owner of record of the named property, or that the owner of record authorizes the proposed work and that I have been authorized by the owner to make this application as his/her authorized agent. I agree to conform to all applicable laws of this jurisdiction. In addition, if a permit for work described in this application is issued, I certify that the Code Official's authorized representative shall have the authority to enter all areas covered by this permit at any reasonable hour to enforce the provisions of the codes applicable to this permit.

Signature of applicant: <u>Pandora LaCase</u>	Date: <u>8/19/05</u>
---	----------------------

This is NOT a permit, you may not commence ANY work until the permit is issued.
If you are in a Historic District you may be subject to additional permitting and fees with the Planning Department on the 4th floor of City Hall

Ivan needs help with grounds care. Linda proposed a clean-up day, exact date to be announced. Members interested in lending a hand should sign up with her.

~~David and Pauline proposed building a deck, at their own expense, over the flat roof outside their porch. The structure would be a LCE and would extend from the porch that is now being replaced. A formal motion was passed by all voting members, except for Linda, who abstained.~~

Richards' unit has a leak. Bob will find a mason to repair the bricks and pointing

The wall north of 80 High St. is bucking. Bob will look at it and include it as an item in his report at the September meeting.

The meeting was adjourned at 8:45 p.m.

Next Regular Board Meeting

Monday, September 12, 5:30, at 80-1 High St. (LaCasse home)

Respectfully Submitted,

Larry Fader, Secretary

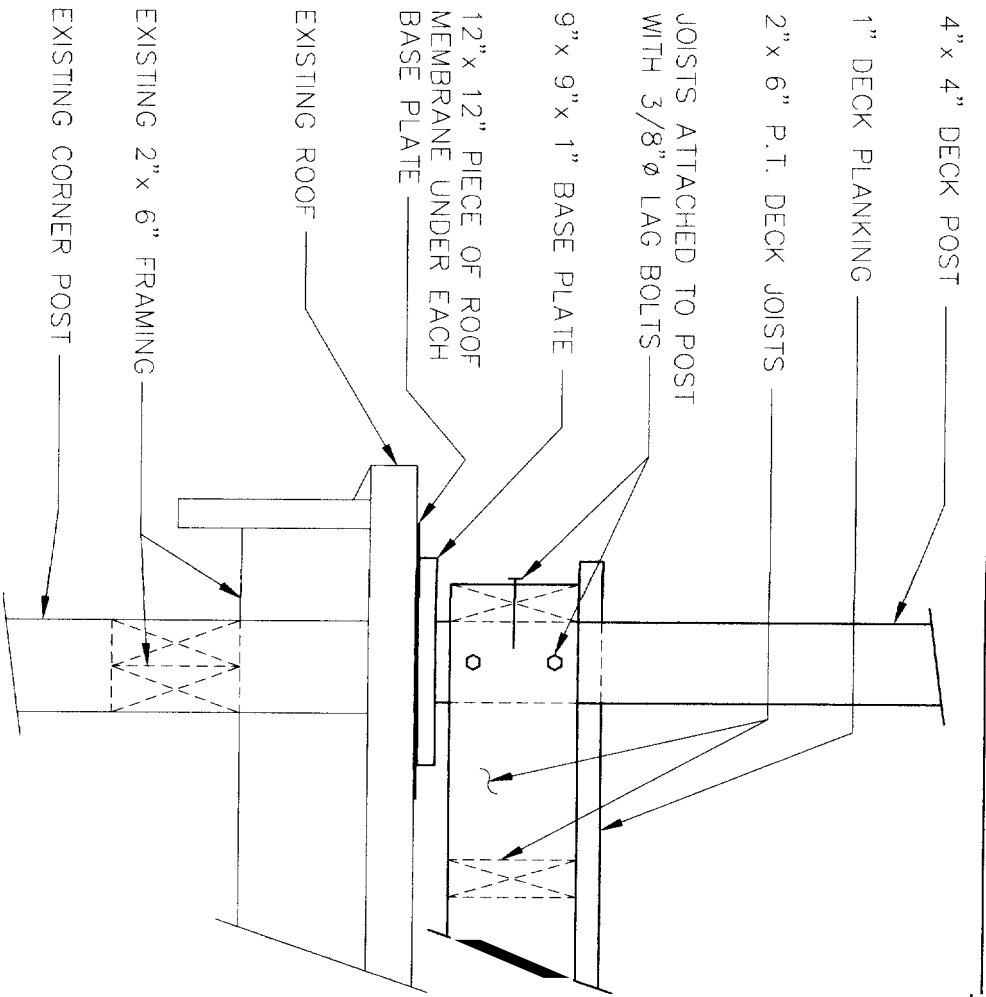

EXISTING ONE-STORY
STRUCTURE IS SUPPORTED
ON CONCRETE PAD

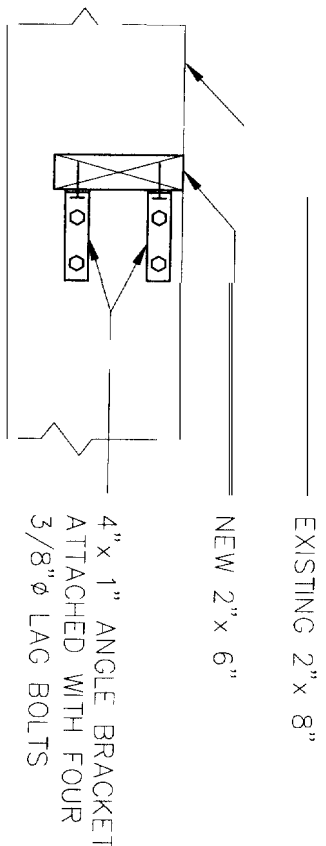
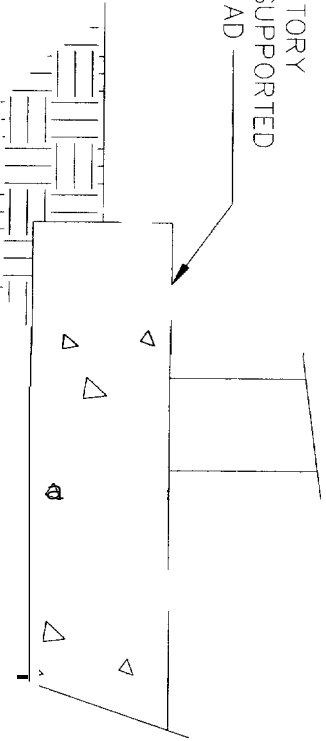

C SECTION
SH 2 ATTACHING NEW 2" x 6"
TO EXISTING 2" x 8"

B SECTION
SH 2 CORNER SUPPORT

David and Pandora LaCasse
80 High Street
Portland, Maine 02901

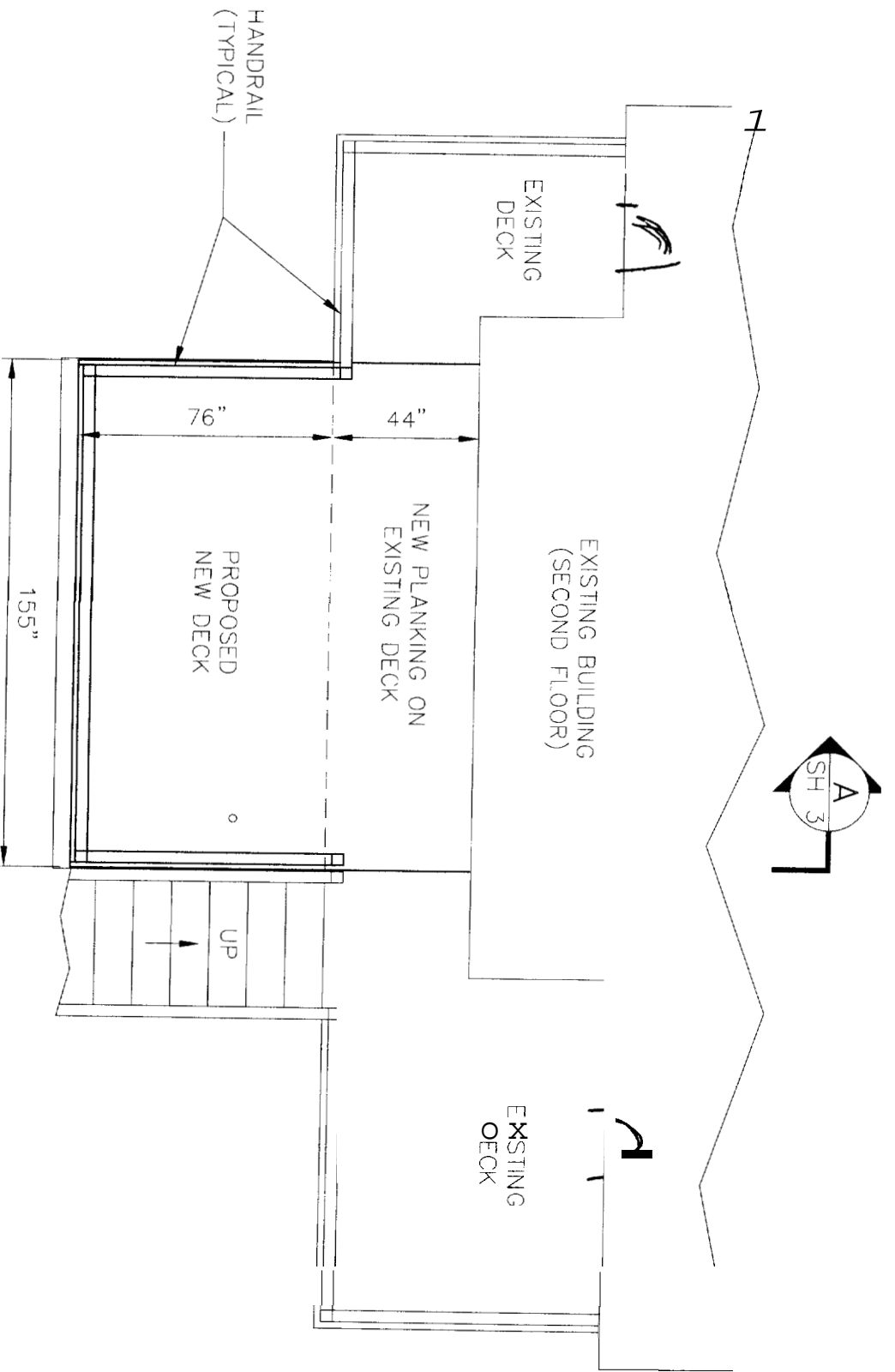

FLOOR PLAN

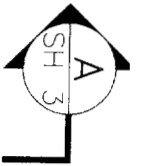
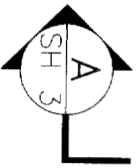

EXISTING DECK

EXISTING BUILDING (SECOND FLOOR)

EXISTING DECK



12" 12" 12" 10" 12" 12" 7"

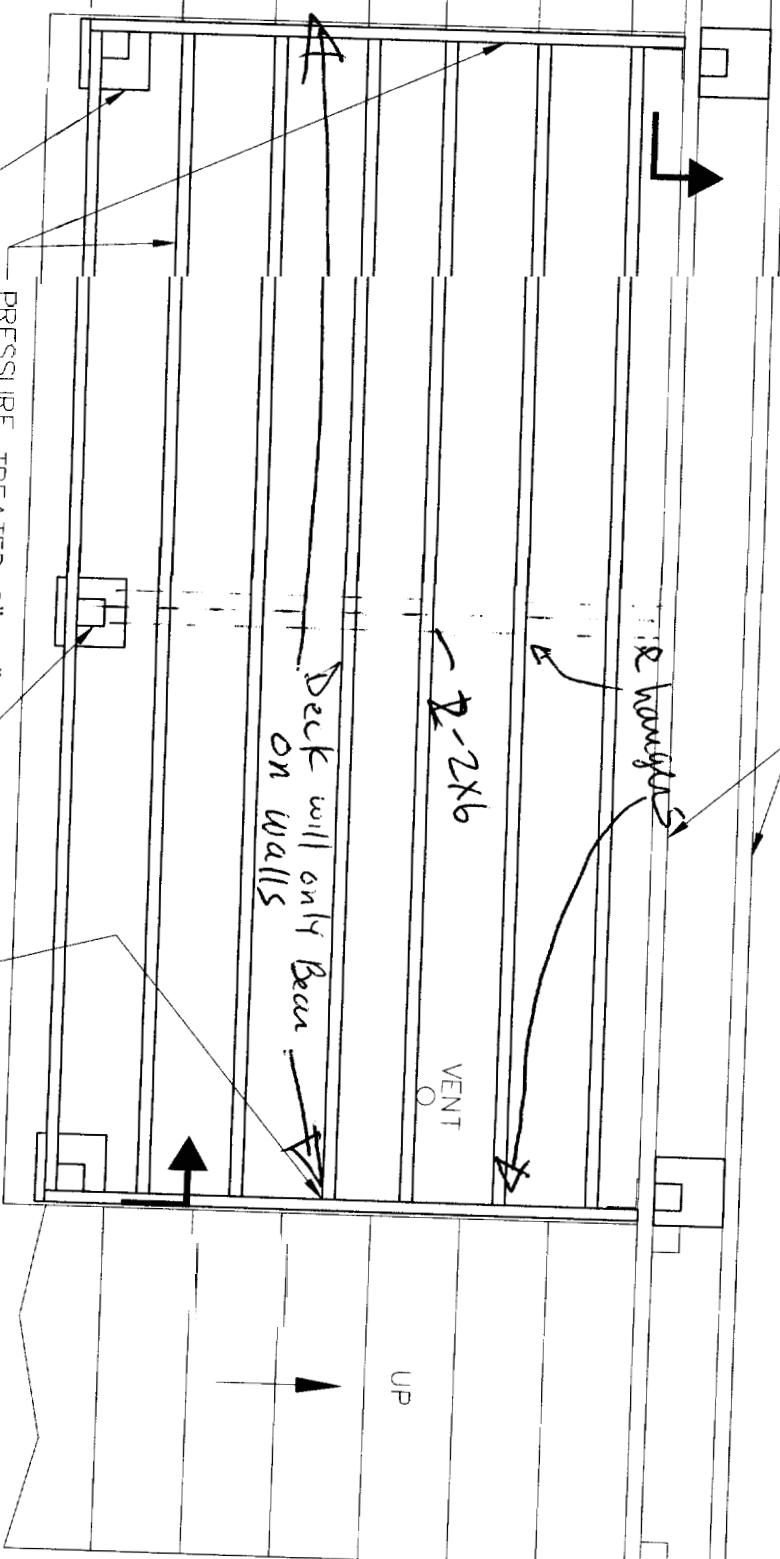

EXISTING 2" x 8" JOISTS

2x6 hangers

2x6

Deck will only Bear on walls

VENT

UP

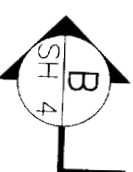

PRESSURE TREATED 2" x 6"

CEDAR 4" x 4" POSTS

9" x 9" x 1" PRESSURE TREATED BASE PLATES

FRAMING PLAN

JOISTS ATTACHED WITH STEEL JOIST HANGERS (EXCEPT SEE SECTIONS B & C FOR PERIMETER JOISTS)

David and Pandora LoCasse
80 High Street
Portland, Maine 02901
SHEET 9

2" x 6" PRESSURE TREATED JOISTS PER
FRAMING PLAN ON SHEET 2

HANDRAIL PER ENLARGED DETAIL BELOW

EXISTING FIRST FLOOR ROOF

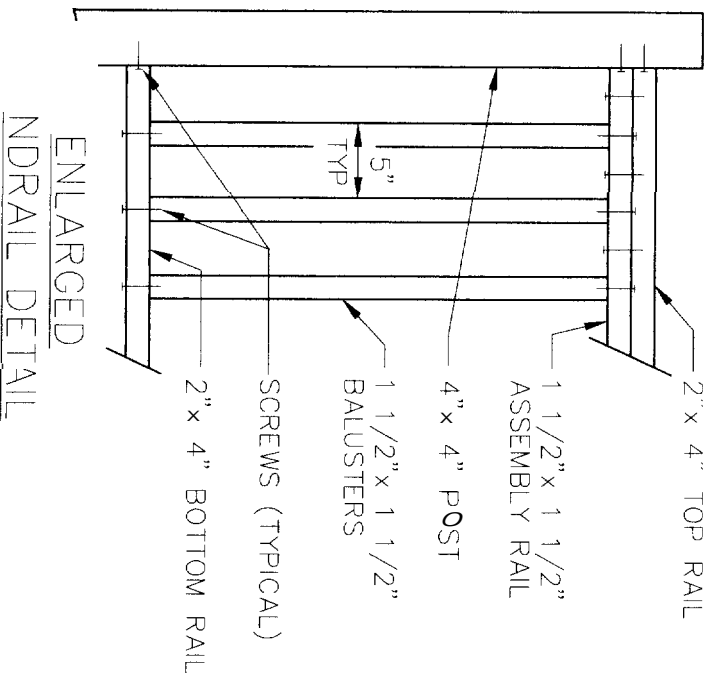

ENLARGED
HANDRAIL DETAIL

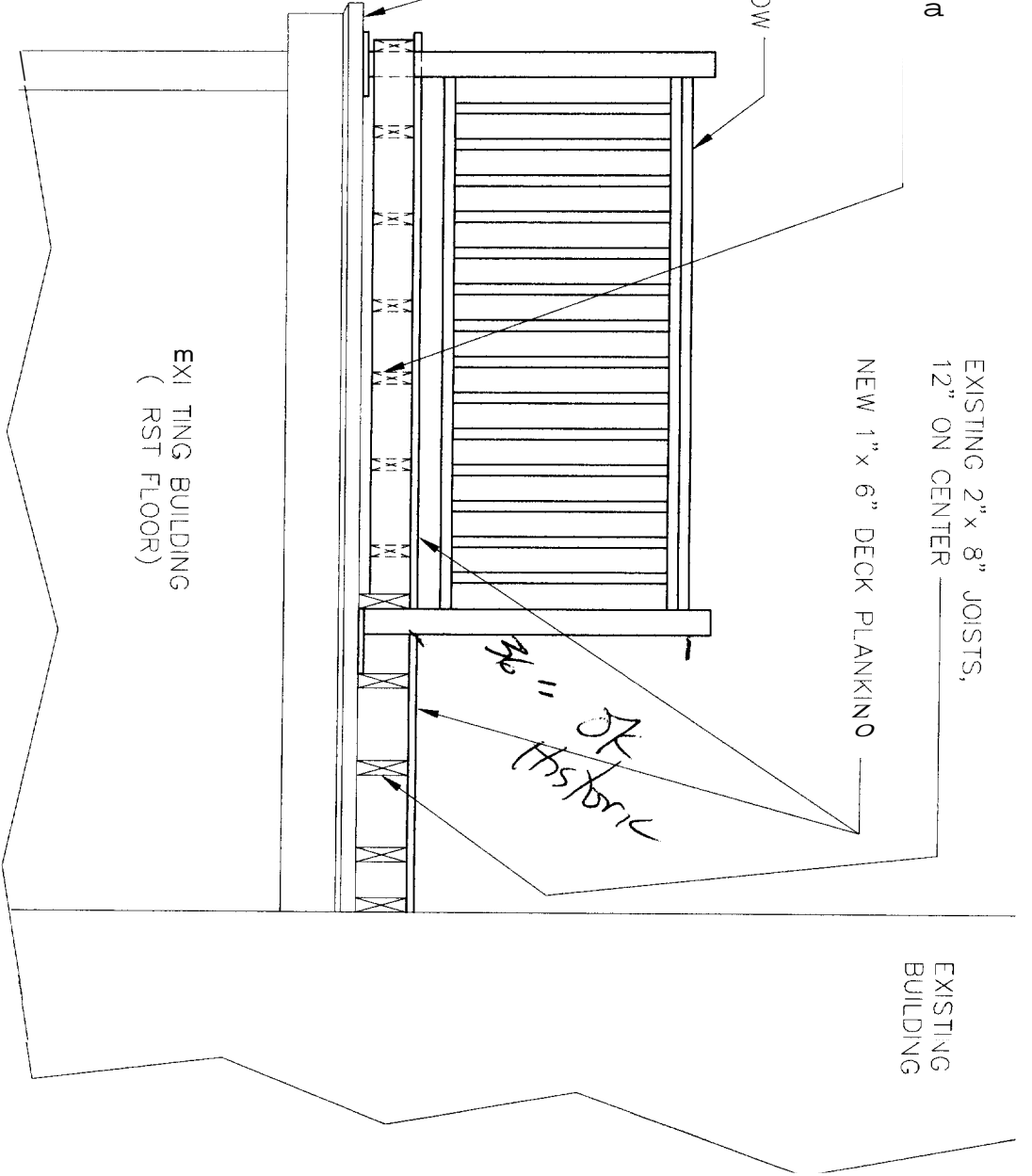

EXISTING BUILDING
(FIRST FLOOR)

A SECTION
SH 1 FRAMING DETAILS

David and Pandora LaCasse
80 High Street
Portland, Maine 02901

SHEET 3



Please call 874-8703 or 874-8693 to schedule your inspections as agreed upon

Permits expire in 6 months, if the project is not started or ceases for 6 months,

The Owner or their designee is required to notify the inspections office for the follow inspections and provide adequate notice. Notice must be called in order to schedule an inspection:

By initialzing at each inspection the, you are agree inspection procedure and additional fees from a "Stop Work Order" and "Stop Work Order Release" will be incurred if the procedure is not fallowed as stated below.

A Pre-construction Meeting will take place upon receipt of your building permit,

- Footing/Building Location Inspection: Prior to pouring concrete
- Re-Bar Schedule Inspection: Prior to pouring concrete
- Foundation Inspection: Prior to placing ANY backfill
- Framing, Rough Plumbing/Electrical: Prior to any insulating or drywalling
- Final Certificate of Occupancy: Prior to any occupancy of the structure or use. **NOTE:** There is a \$75.00 fee per inspection at this point.

Certificate of Occupancy is not required for certain projects. Your inspector can advise you if your project requires a Certificate of Occupancy. All projects DO require a final inspection

Plus If any of the inspections do not occur, the project cannot go on to the next phase. **REGARDLES OF THE NOTICE OR CIRCUMSTANCES.**

N/A **CERIFICATE OF OCCUPANICES MUST BE ISSUED AND PAID FOR, BEFORE THE SPACE MAY BE OCCUPIED**

Panda, Anne
Signature of App cant/Designee

1/11/05
Date

[Signature]
Signature of Inspections Official

1 Nov 05
Date

CBL: 0396010-000 Building Permit #:

251111