

ROOF FRAMING REPAIR PLAN AT 5th OFFICE  
 1/4"=1'-0"  
 FIELD VERIFY ALL DIMENSIONS AND ELEVATIONS.

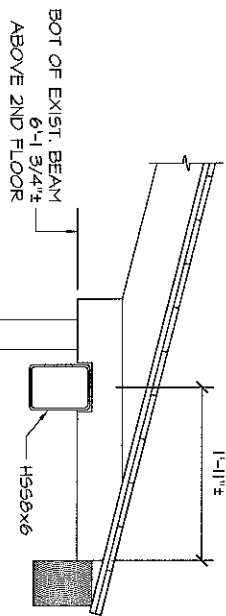

SECTION 1  
 3/4"=1'-0" S6

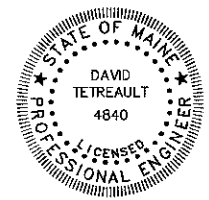
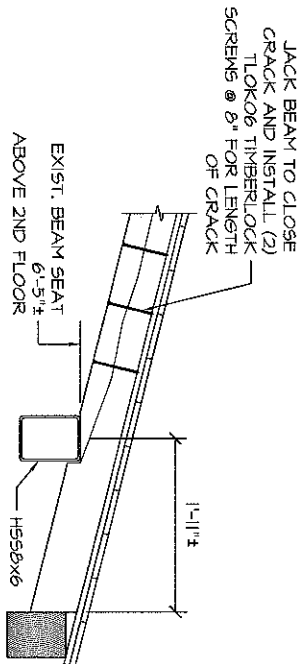

SECTION 2  
 3/4"=1'-0" S6

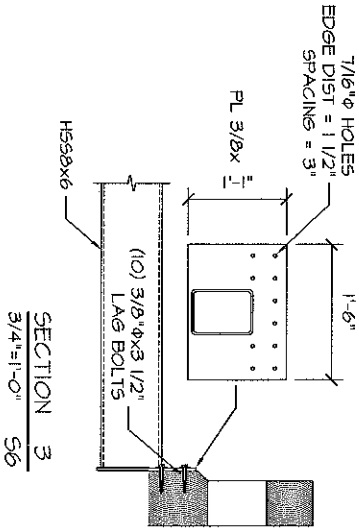

SECTION 3  
 3/4"=1'-0" S6

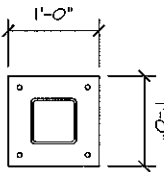

BASE PLATE DETAIL  
 3/4"=1'-0"  
 THICKNESS = 1/2"  
 HOLE DIA. = 5/8"  
 HOLE EDGE DIST = 1 1/2"

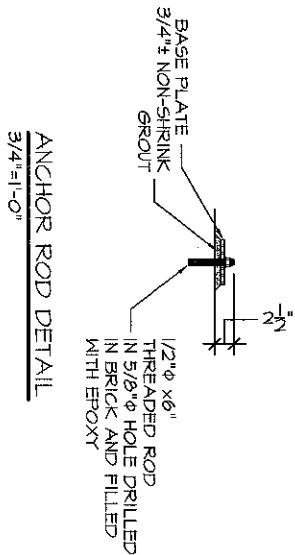

ANCHOR ROD DETAIL  
 3/4"=1'-0"

date	revision number
02/22/12	

RENTAL PROPERTY OF NEVA CRAM AND KERRY DRACH  
 130 - 132 PLEASANT STREET  
 PORTLAND, MAINE

