

New entrance opening & new stair to Lvl 2 above. Provide 2 hr.-rated soffit under stair. Provide temporary barrier at Lvl 1 around work area to segregate noise, dust, etc. Coordinate schedule of work with existing Tenant and expedite work to greatest degree practical. Restore any casework or other item that is temporarily removed due to new work. Restore all surfaces to original condition.

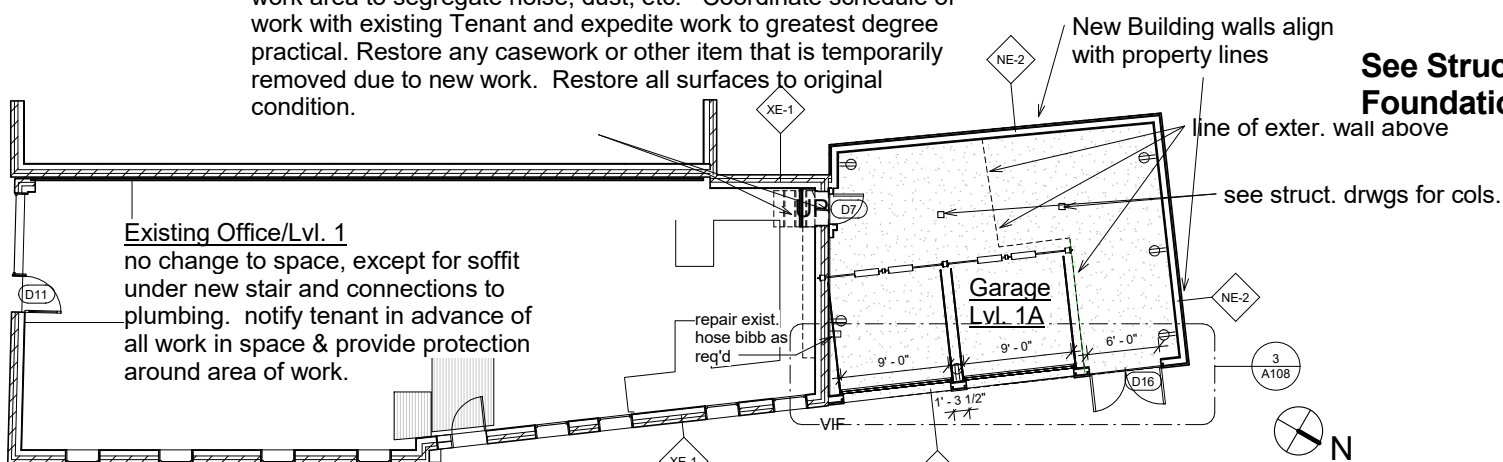

1 Existing Level 1 w new construction  
1/8" = 1'-0"

**See Structural Drawings for Foundation Plan**

Wall Schedule			
Type Mark	Description	Family and Type	Comments
NI-9	New Glass Partition	Basic Wall: 3/8" temp glass wall	
XE-2	Existing parapet wall	Basic Wall: Chimney wall	existing
XE-1	Existing 8" Brick Wall w/ Int Insuling	Basic Wall: Double Wythe Brick Inter studs	
NE-2	New Exterior Mtl. Panel Wall	Basic Wall: Exterior - Mtl Pnl on Wd Stud	
NE-3		Basic Wall: Generic - 6" Masonry	
NE-4		Basic Wall: Generic - 8" - Filled	foundation - see structural
NXI-1	New or Exist. Interior Furring	Basic Wall: Interior - 1.5" stud furring	
NI-7	New Cab Wall	Basic Wall: Interior - 2 layer plywood	
NI-1	Interior Partition	Basic Wall: Interior - 3.5" stud & gyp	
XI-3	Existing Partial Hgt wall	Basic Wall: Interior - 3.5" stud & gyp partial hgt	
NI-10	Interior Partition	Basic Wall: Interior - 3.5" stud & gyp w insul	thermal insul in wall
NI-2	New Interior Furring	Basic Wall: Interior - 3.5" stud furring	
		Basic Wall: Interior - 5 1/2" Partition (1-hr)	
NI-4	Interior Partition	Basic Wall: Interior - 5.5" stud & gyp	or as req'd for plumb. lines
NI-3	New Interior Insul. Wall	Basic Wall: Interior - Insul staggrd 3.5" stud & gyp 2	acoustic & thermal insul. wall
NI-8	New Cab. Wall	Basic Wall: Interior Cab wall- 1 layer plywood	

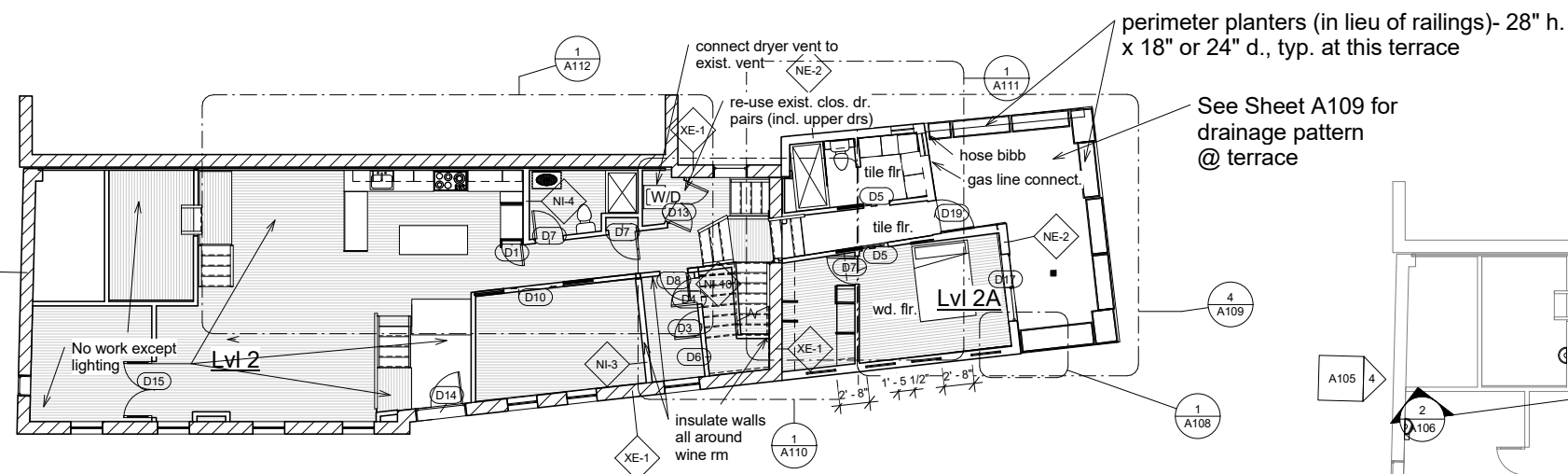

2 Existing Level 2 w new construction  
1/8" = 1'-0"

**Note:** Planters, interior railings, new awning & interior steel base by Owner's subcontractor. GC to coordinate w/ Sub for installation.

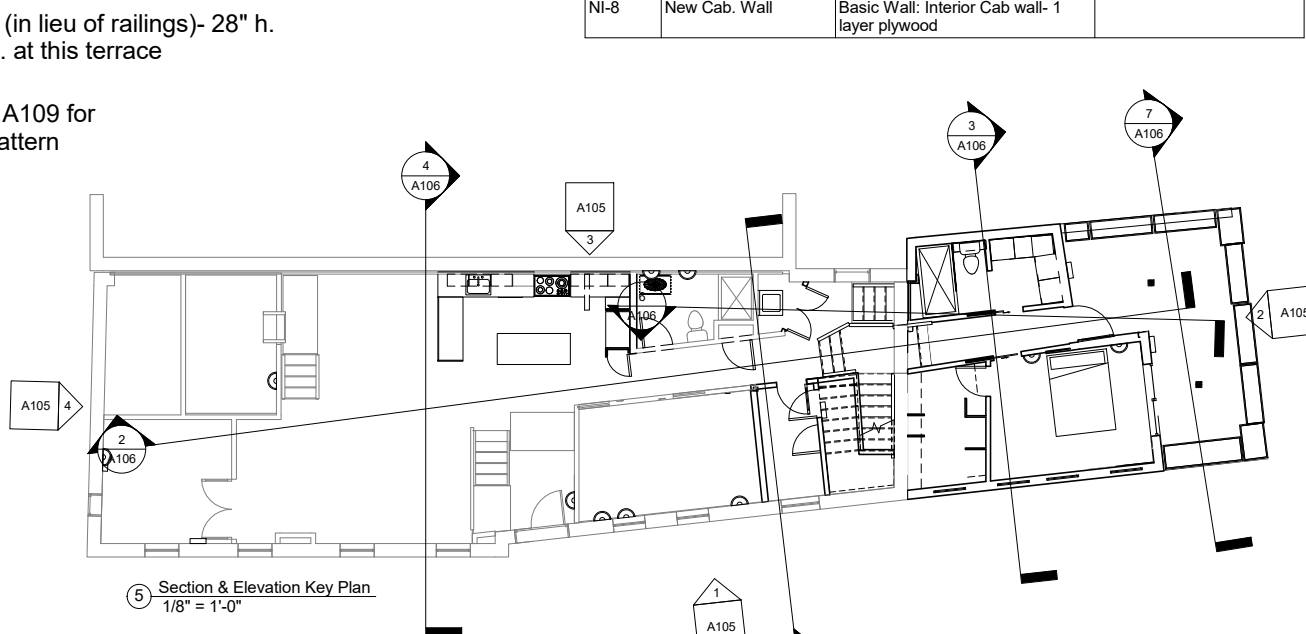

5 Section & Elevation Key Plan  
1/8" = 1'-0"

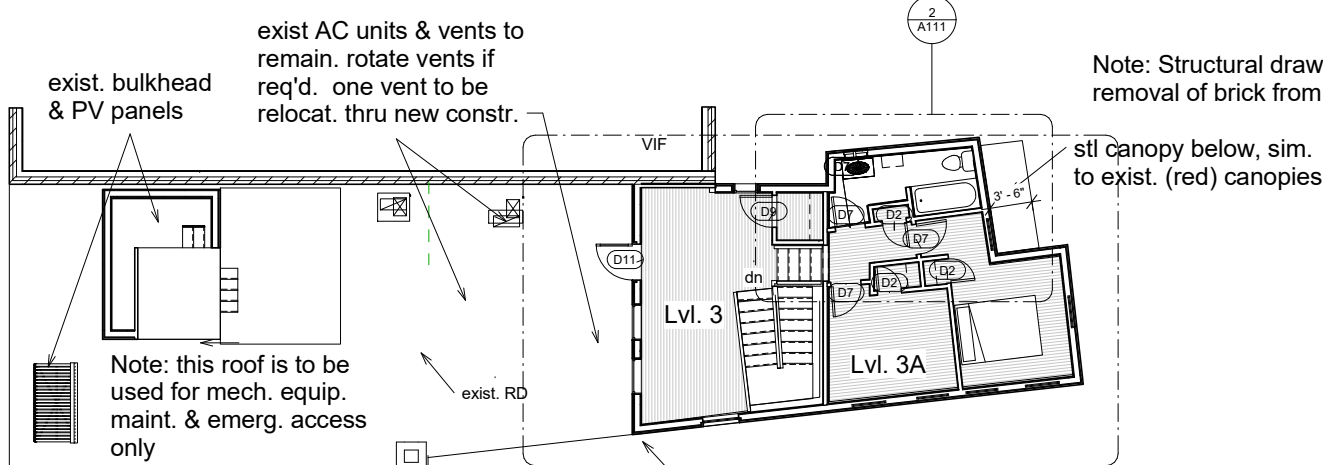

3 Existing Roof Plan w new construction  
1/8" = 1'-0"

Note: Structural drawings not yet revised for revised terrace shape @ Lvl. 2A; revised shape of upper roofs @ Lvl. 3/3A; removal of brick from east elevation. Structural Engineer will modify these drawings prior to construction.

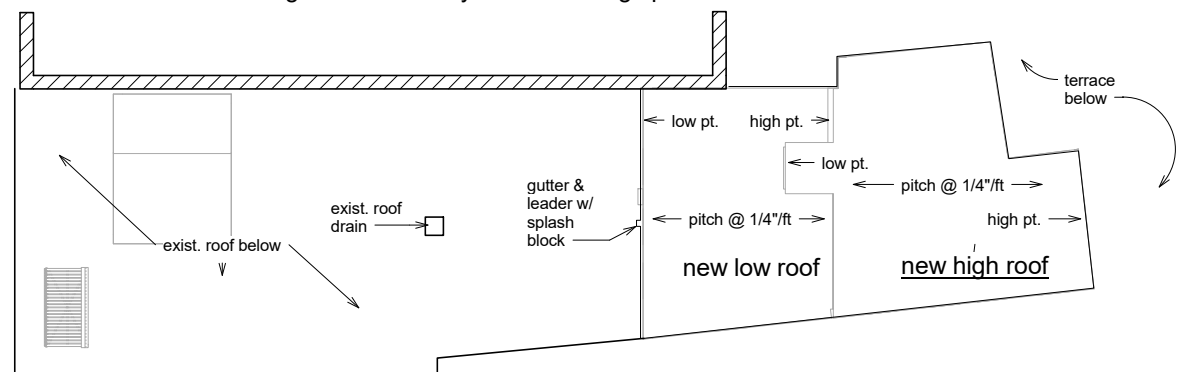

4 New Roof Plan  
1/8" = 1'-0"

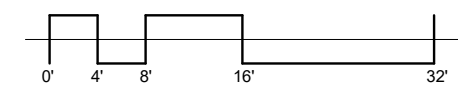

**Reiter Architecture & Design**  
PO Box 275, Brooklin ME 04616 tel. 917-502-2225 email: laurenreiter@yahoo.com

**Becker Structural Engineers**  
75 York St # 3, Portland, ME 04101 Tel: (207) 879-1838

Revision Schedule		
Revision Number	Revision Description	Revision Date
	Issued for permit	2/14/16

**Reiter Residence**  
35 Pleasant Street /  
6 South Street  
Portland, Maine 04101  
**RENOVATION**

**Proposed Plans**

Project number	RENOVATION
Date	Issue Date
Drawn by	Author
Checked by	Checker

**A104**

Scale 1/8" = 1'-0"