

LEVEL C PLAN AT STAIR TOWER #1
1/4"=1'-0"

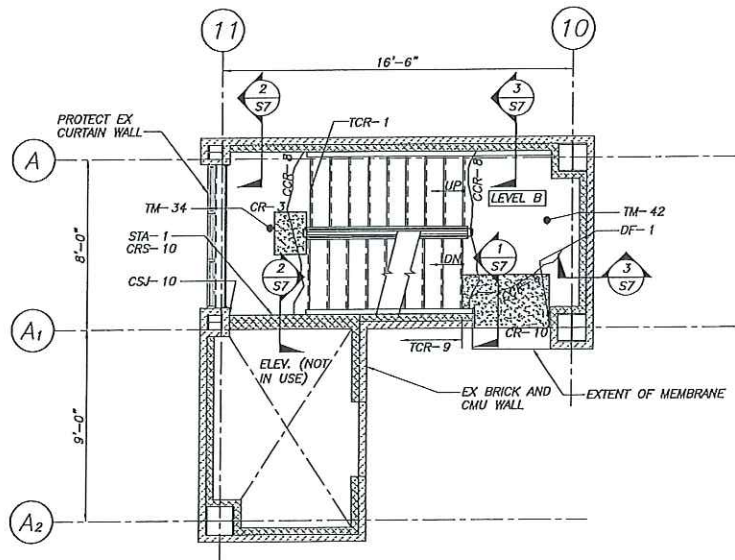

LEVEL B PLAN AT STAIR TOWER #1
1/4"=1'-0"

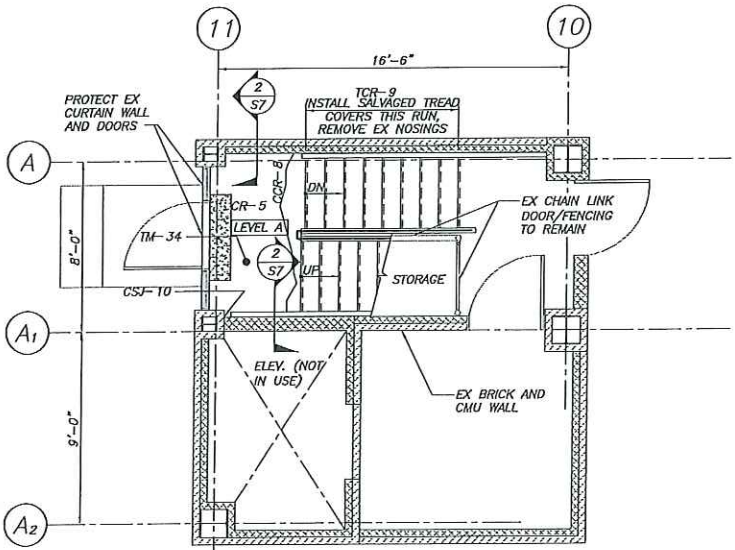

LEVEL A PLAN AT STAIR TOWER #1
1/4"=1'-0"

SCOPE OF WORK - STAIR #1					
ITEM	WORKCODE	DESCRIPTION	QUANTITY	UNIT	NOTES
1	DF	DOOR FRAME REMOVAL AND JAMB REPAIR	3	EA	REF DWG S7
2	STA	REPLACE LANDING SUPPORT ANGLE	4	EA	REF DWG S7
3	TCR	TREAD COVER REMOVAL/REINSTALL AND TREAD REPAIR	33	EA	REF DWG S7
4	TM	PEDESTRIAN MEMBRANE AT LANDINGS	405	SF	REF DWG S6
5	CR	CONCRETE REPAIR	35	SF	REF DWG S5
6	CCR	CRACK CHASE REPAIR	80	LF	REF DWG S5
7		PREP AND PAINT STEEL STAIR FRAMING	1	STAIRWAY	REF DWG S0
8		PAINT WALLS AND CEILING	3,300	SF	REF DWG S0
9	STL	REPLACE DOOR LINTELS AT LVL D	1	EA	REF DWG S7
10	CCC	COLUMN COVER CMU REPLACEMENT	1	COVER	REF DWG S5
11	CRS	ROUT/SEAL CMU CRACK	25	LF	REF DWG S5
12	CSJ	CUT OUT AND REPLACE MASONRY CONTROL JOINT	25	LF	REF DWG S5
13	SC	CUT AND AND REPLACE CURTAIN WALL TO CMU JOINT SEALANT	45	LF	REF DWG S5

NOTES:
1. QUANTITIES SHOWN IN THE SCHEDULE ABOVE MAY BE GREATER THAN WHAT ARE SHOWN ON THE PLAN.
2. ALL QUANTITIES SHOULD BE FIELD VERIFIED.

- LEGEND
- CRACK CHASE REPAIR
 - ▨ CONCRETE LANDING REPAIR
 - ▩ STAIR LANDING REPLACEMENT
 - ▧ OVERHEAD SPALL REPAIR
 - ▤ CMU WALL
 - ▥ BRICK MASONRY WALL
- WORK CODE LEGEND
- FCJ-20
 - QUANTITY
 - WORK CODE INDICATOR
 - IDENTIFYING SYMBOL (REF LEGEND)

- STAIR TOWER #1 PAINTING NOTES:
- REFERENCE DRAWING S0 AND SPECIFICATIONS FOR ADDITIONAL PAINTING AND SURFACE PREPARATION REQUIREMENTS.
 - ALL EXPOSED STEEL WITHIN STAIR TOWER IS TO BE PREPARED AND PAINTED INCLUDING BUT NOT LIMITED TO STAIR FRAMING, HANDRAILS, GUARDRAILS, STEEL ATTACHMENTS TO THE CURTAIN WALL AND MISCELLANEOUS EXPOSED STRUCTURAL STEEL.
 - ALL STAND AND DRAIN PIPES ARE TO BE PREPPED AND PAINTED.
 - THE STAIR TOWER WALLS AND CEILING ARE TO BE PAINTED. THE UNDERSIDE OF THE CONCRETE LANDINGS ARE TO BE SCRAPPED OF LOOSE PAINT AND REMAIN UNPAINTED.
 - ELECTRICAL BOXES, LIGHTS AND EMERGENCY LIGHTS DO NOT NEED TO BE REMOVED AND CAN BE PAINTED AROUND. ELECTRICAL CONDUIT DOES NOT NEED TO BE REMOVED BUT SHOULD BE PAINTED TO MATCH THE WALLS. PROTECTION CAGES AROUND THE LIGHTS ARE TO BE REMOVED, PAINTED AND RESET. CONTRACTOR TO REMOVE AND REINSTALL ALL SIGNS ATTACHED TO THE WALL PRIOR TO PAINTING.

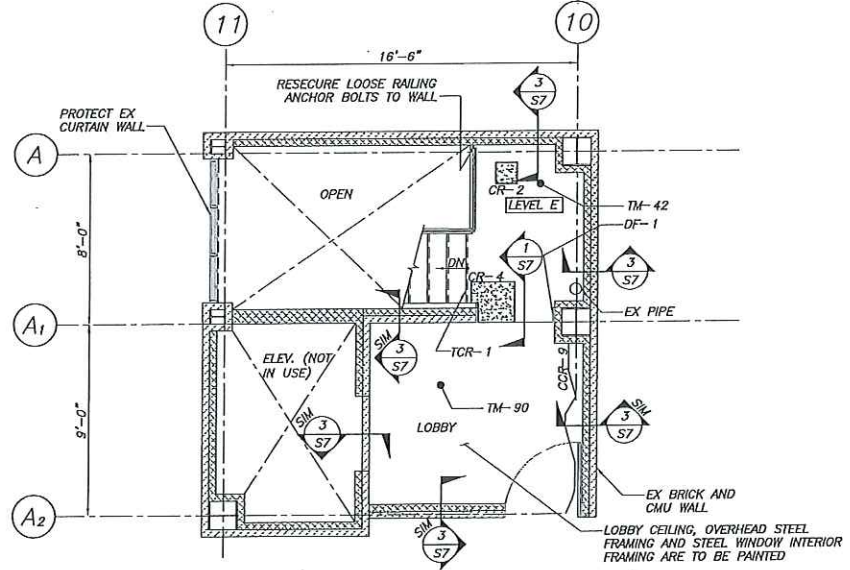

LEVEL E PLAN AT STAIR TOWER #1
1/4"=1'-0"

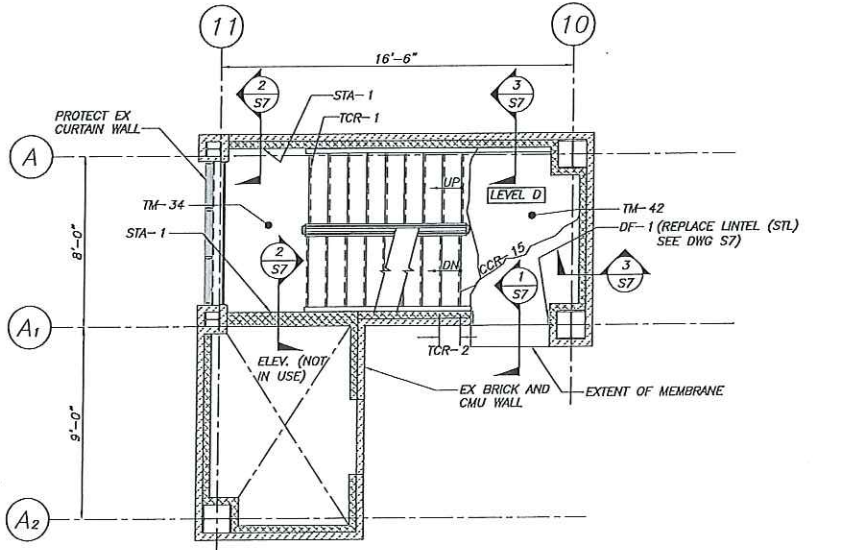

LEVEL D PLAN AT STAIR TOWER #1
1/4"=1'-0"

THIS DRAWING IS AN INSTRUMENT OF SERVICE AND SHALL REMAIN THE PROPERTY OF BECKER STRUCTURAL ENGINEERS INC. IT SHALL NOT BE REPRODUCED, COPIED, LENT OR DISPOSED OF DIRECTLY OR INDIRECTLY FOR ANY PURPOSE OTHER THAN THAT FOR WHICH IT IS SPECIFICALLY FURNISHED AND MUST BE RETURNED TO BECKER STRUCTURAL ENGINEERS INC. ON COMPLETION OF WORK, IF REQUESTED.

Issue For	11/30/17 FOR BID
Date	11/30/17
Rev No	1

SPRING STREET PARKING GARAGE
PORTLAND, MAINE
STAIR REPAIRS
STAIR #1 PLANS

Designed	JMM	Scale	AS NOTED
Drawn	RJB	Date	11/30/17
Checked	JMM	Becker Job Number	4198