

COPYRIGHT: Reuse or reproduction of the contents of this document is not permitted without written permission of Bild Architecture LLC

CEILING TYPES

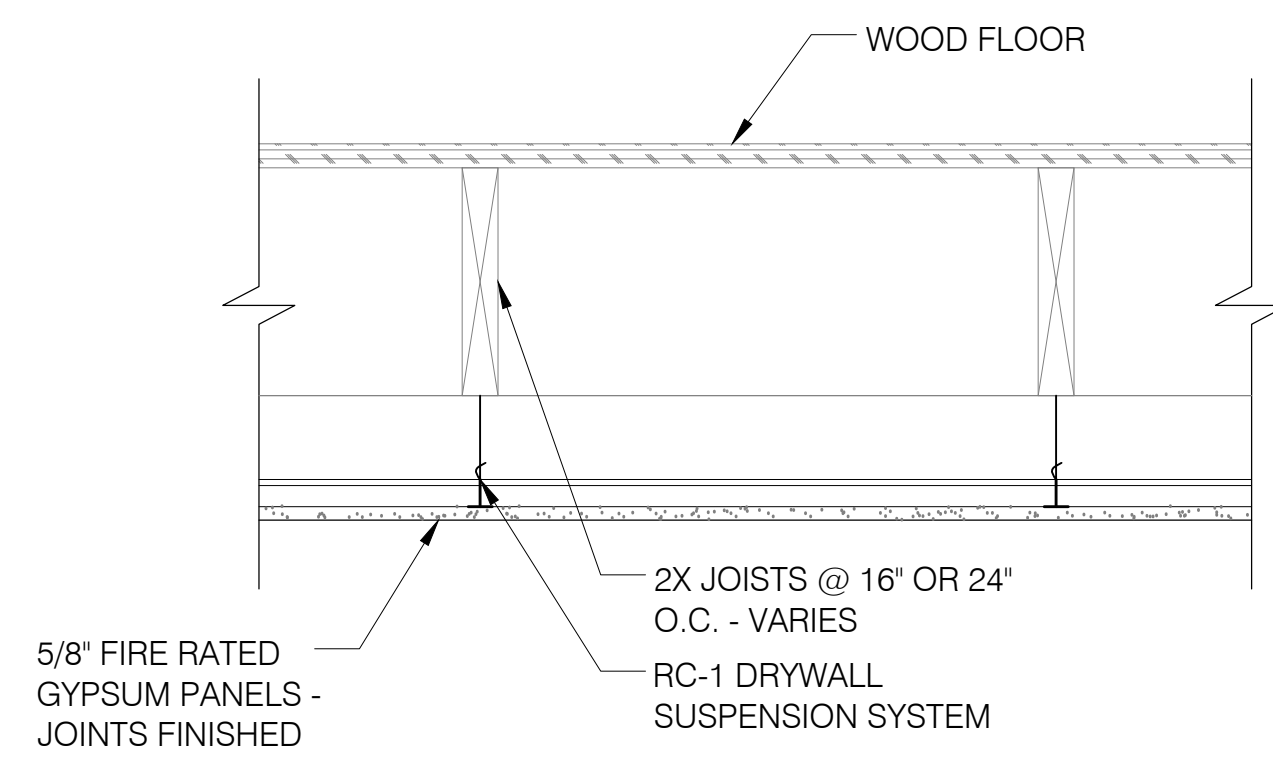

C1	SUSPENDED GYP BD CEILING 1 HOUR RATED UL-L569 ASSEMBLY
	12 5/8" ACTUAL CEILING THICKNESS

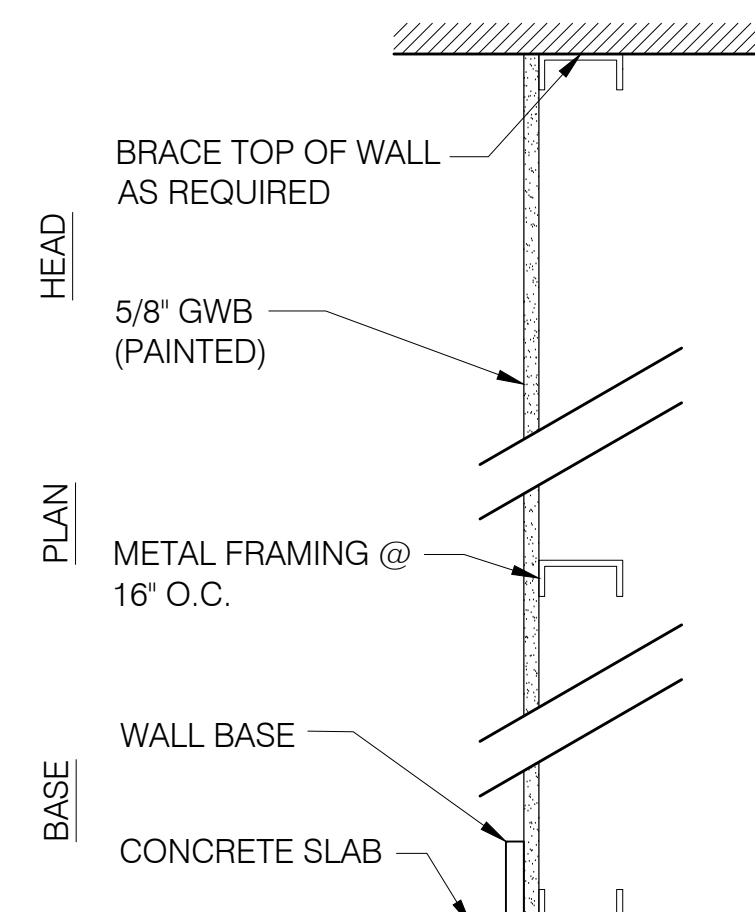

W1	CHASE WALL
	4 1/8" ACTUAL WALL THICKNESS

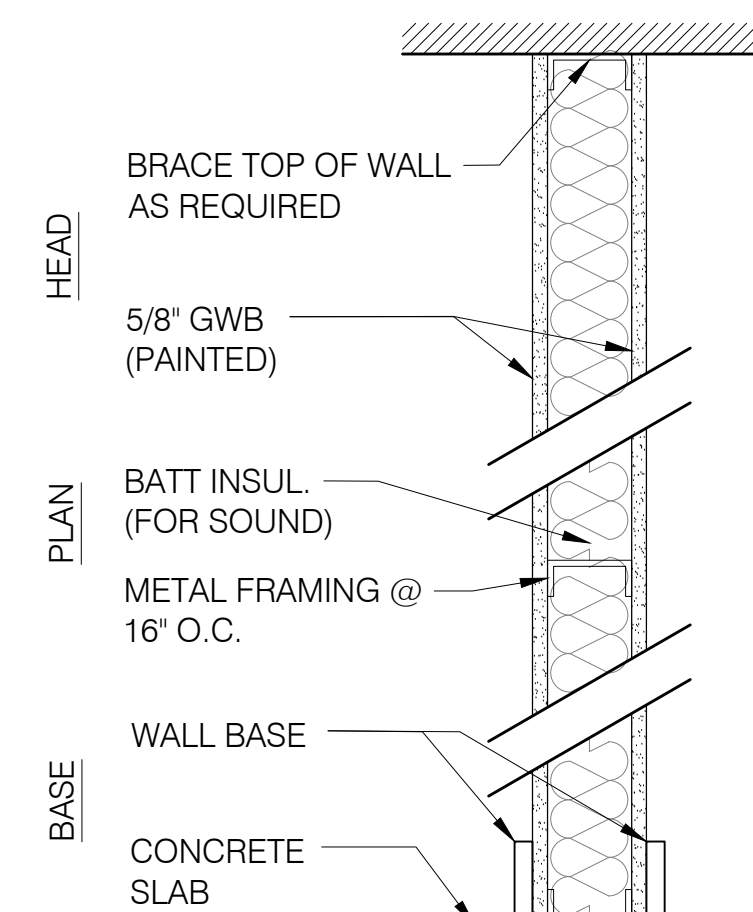

W2	2X4 METAL FRAMING ACOUSTICAL WALL
	4 3/4" ACTUAL WALL THICKNESS

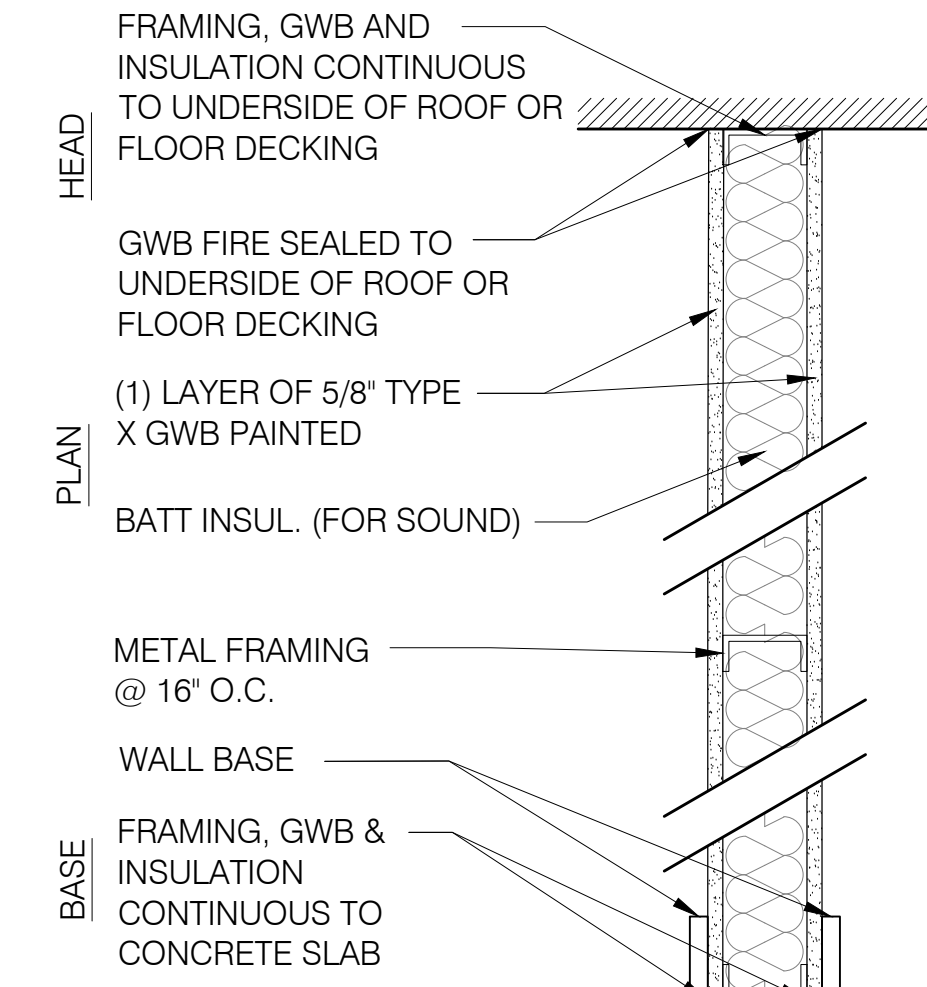

1H	2X4 WOOD FRAMING FIRE WALL 1 HOUR RATED UL-U419 ASSEMBLY
	4 3/4" ACTUAL WALL THICKNESS

WALL TYPES

GENERAL NOTES

- ALL MATERIALS, COMPONENTS, AND WORK ARE NEW AND SHALL BE PROVIDED IN THIS CONTRACT BY THE CONTRACTOR UNLESS NOTED OTHERWISE.
- ALL WORK INCLUDED IN THIS CONTRACT SHALL CONFORM TO ALL STATE, NATIONAL AND OTHER CODES AND ORDINANCES WHICH APPLY TO THIS PROJECT.
- IT IS THE INTENT AND MEANING OF THESE DRAWINGS THAT THE CONTRACTOR AND EACH SUBCONTRACTOR PROVIDE ALL LABOR, MATERIALS, TRANSPORTATION, SUPPLIES, EQUIPMENT, ETC. TO OBTAIN A COMPLETE JOB TO INDUSTRY STANDARD IN A PROFESSIONAL WORKMANLIKE MANNER.
 - CONTRACTORS AND SUBCONTRACTORS SHALL REVIEW THE DRAWINGS AND SPECIFICATIONS PRIOR TO PERFORMANCE OF ANY WORK.
 - CONTRACTORS AND SUBCONTRACTORS SHALL INSTALL ALL MATERIALS AS PER THE CONSTRUCTION DOCUMENTS AND THE MANUFACTURER'S INSTALLATION RECOMMENDATIONS.
 - INSTALLERS MUST BE TRAINED AND EXPERIENCED IN THE APPLICATION/INSTALLATION OF THE PRODUCTS/MATERIALS THAT THEY ARE INSTALLING.
 - PRODUCTS/MATERIALS MUST BE APPLIED/INSTALLED/USED IN CONDITIONS AS ALLOWED BY THE MANUFACTURER.
 - PRODUCTS/MATERIALS MUST BE APPLIED/INSTALLED/USED IN COORDINATION WITH ALL OTHER WORK CONDUCTED ON SITE.
- THE CONTRACTOR SHALL FIELD VERIFY ALL EXISTING CONDITIONS AND REPORT ANY DISCREPANCY(IES) IMMEDIATELY TO THE OWNER.
- ANY DEVIATIONS WHATSOEVER FROM THE DRAWINGS AND/OR SPECIFICATIONS ARE NOT ALLOWED WITHOUT THE OWNER'S WRITTEN PERMISSION. FAILURE TO PROCURE SUCH WRITTEN AUTHORIZATION PLACES ALL RESPONSIBILITY FOR THE VARIATION ON THE CONTRACTOR.
- AT THE END OF EACH WORKING DAY, THE CONSTRUCTION SITE SHALL BE LEFT IN A NEAT AND CLEAN MANNER.
- THE CONTRACTOR SHALL BE RESPONSIBLE FOR OBTAINING ALL PERMITS WHICH ARE REQUIRED FOR THE SATISFACTORY COMPLETION OF THE WORK AND THE OWNER SHALL BE RESPONSIBLE FOR PAYING ALL FEES, HOOK UP CHARGES, ETC.
- THE CONTRACTOR SHALL OBTAIN APPROVAL FROM THE OWNER FOR THE SEQUENCE AND TIMING OF OPERATIONS PRIOR TO COMMENCING WORK. AREAS FOR STAGING ETC. MUST BE APPROVED BY THE OWNER.
- THE CONTRACTOR SHALL DISPOSE OF AND / OR RECYCLE ANY CONSTRUCTION DEBRIS FROM THE PROJECT SITE AS REQUIRED BY REGULATING AGENCIES. THE CONTRACTOR SHALL BE RESPONSIBLE FOR OBTAINING DISPOSAL PERMITS WHICH ARE REQUIRED. CONSTRUCTION DEBRIS FROM THE PROJECT SITE SHALL BE DISPOSED OF IN AN APPROVED AND LEGAL MANNER.
- DUTY OF COOPERATION: RELEASE OF THESE PLANS CONTEMPLATES FURTHER COOPERATION AMONG THE OWNER, THE CONTRACTOR, THE ARCHITECT AND THE ARCHITECT'S CONSULTANTS. DESIGN AND CONSTRUCTION ARE COMPLEX. ALTHOUGH THE ARCHITECT AND HIS CONSULTANTS HAVE PERFORMED THEIR SERVICES WITH DUE CARE AND DILIGENCE, THEY CANNOT GUARANTEE PERFECTION. COMMUNICATION IS IMPERFECT, AND EVERY CONTINGENCY CANNOT BE ANTICIPATED. ANY AMBIGUITY OR DISCREPANCY DISCOVERED BY THE USE OF THESE PLANS SHALL BE REPORTED IMMEDIATELY TO THE OWNER. FAILURE TO NOTIFY THE OWNER COMPOUNDS MISUNDERSTANDING AND MAY INCREASE CONSTRUCTION COSTS. A FAILURE TO COOPERATE BY A SIMPLE NOTICE TO THE OWNER SHALL RELIEVE THE OWNER AND THE ARCHITECT FROM RESPONSIBILITY FROM ALL COSTS.
- THESE DRAWINGS DO NOT INCLUDE THE NECESSARY COMPONENTS FOR CONSTRUCTION SAFETY. THE GENERAL CONTRACTOR SHALL PROVIDE FOR THE SAFETY, CARE OF UTILITIES AND ADJACENT PROPERTIES DURING CONSTRUCTION, AND SHALL COMPLY WITH STATE AND FEDERAL SAFETY REGULATIONS.
- ALL MATERIALS AND WORK SHALL BE GUARANTEED FOR A MINIMUM OF ONE YEAR FROM THE DATE OF FINAL PAYMENT.
- COORDINATE ALL MECHANICAL & ELECTRICAL DEVICES SO THEY DO NOT CONFLICT W/ ARCHITECTURAL FEATURES.
- ELECTRICAL WORK TO BE DESIGNED, PERMITTED AND INSTALLED BY CONTRACTOR.
- EXISTING ELECTRICAL SYSTEM TO BE PRESERVED TO THE MAXIMUM EXTENT ALLOWABLE BY CODE.
- PLUMBING WORK TO BE DESIGNED, PERMITTED AND INSTALLED BY CONTRACTOR.
- HVAC WORK TO BE DESIGNED, PERMITTED AND INSTALLED BY CONTRACTOR.



Bild Architecture
PO Box 8235
Portland, ME
04104
207.408.0168
evan@bildarchitecture.com



PROJECT NO.
16015
PROJECT NAME
HEAD GAMES
PORTLAND, ME

REVISIONS	DATE	DESCRIPTION
1	12.7.2016	
2	1.31.2017	
3	4.18.2017	
4		
5		

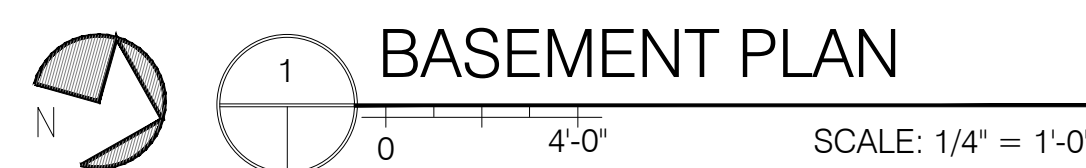
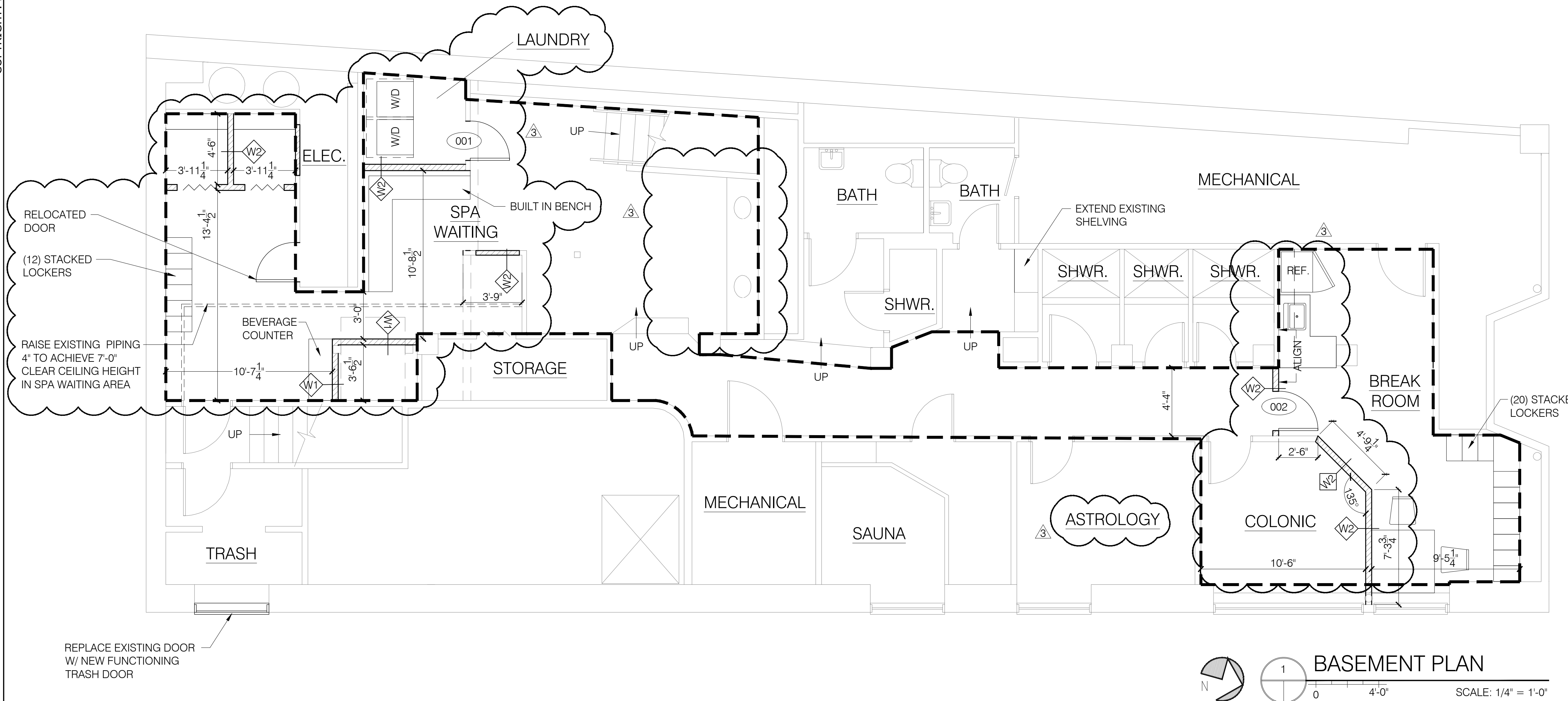
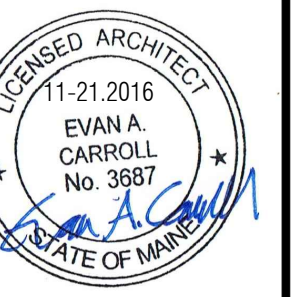
PERMITTING DRAWINGS
DRAWN BY
AEW
SHEET TITLE
BASEMENT PLAN

ISSUE DATE
11.21.16
SHEET SCALE
1/4" = 1'-0"

A
1.0