

## Installation, Operation and Maintenance Manual

Please read and save these instructions for future reference. Read carefully before attempting to assemble, install, operate or maintain the product described. Protect yourself and others by observing all safety information. Failure to comply with instructions could result in personal injury and/or property damage!

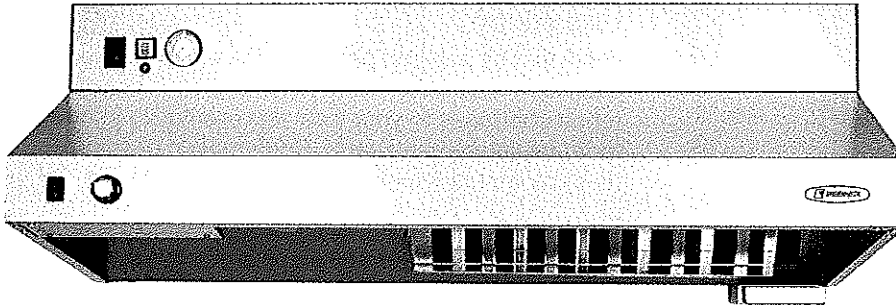

Listed to UL 300A Standard

### WARNING

To reduce the risk of fire, electric shock, or injury to persons, observe the following:

- Use this unit only in the manner intended by the manufacturer.
- Before servicing or cleaning unit, switch power off at service panel and lock the service disconnecting means to prevent power from being switched on accidentally. When the service disconnecting means cannot be locked, securely fasten a prominent warning device, such as a tag, to the service panel.
- Installation work and electrical wiring must be done by a qualified person(s) in accordance with all applicable codes and standards, including fire rated construction codes and standards.
- Sufficient air is needed for proper combustion and exhausting of gases through the flue (chimney) of fuel burning equipment to prevent backdrafting. Follow the heating equipment manufacturer's guideline and safety standards such as those published by the National Fire Protection Association (NFPA), and the American Society of Heating, Refrigeration and Air Conditioning Engineers (ASHRAE), and the local code authorities.
- When cutting or drilling into wall or ceiling, do not damage electrical wiring and other hidden utilities.
- To reduce the risk of fire or electric shock, do not use this range hood with an additional speed control device.
- Ducted fans must always be vented to the outdoors.
- To reduce the risk of fire, use only metal ductwork.
- Use with approved wiring only.
- This unit must be grounded.

### WARNING

To reduce the risk of range top grease fire:

- Never leave surface units unattended at high settings. Boilovers cause smoking and greasy spillovers that may ignite. Heat oils slowly on low or medium settings.
- Always turn hood ON when cooking at high heat or when cooking flaming foods.
- Clean ventilation fans frequently. Grease should not be allowed to accumulate on fan or filter.
- Use proper pan size. Always use cookware appropriate for the size of the surface element.

To reduce the risk of injury to persons in the event of a range top grease fire, observe the following:\*

- SMOTHER FLAMES with a close-fitting lid, cookie sheet, or metal tray, then turn off the burner. BE CAREFUL TO PREVENT BURNS. If the flames do not go out immediately, EVACUATE AND CALL THE FIRE DEPARTMENT.
- NEVER PICK UP A FLAMING PAN. You may be burned.
- DO NOT USE WATER, including wet dishcloths or towels - violent steam explosion will result.

\*Based on "Kitchen Fire Safety Tips" published by NFPA.

## Table of Contents

Receiving, Unpacking, Handling & Storage . . . . .	2
Model Number Code . . . . .	3
Parts Checklist . . . . .	3
Exploded View . . . . .	3
Sample Installations . . . . .	4
Preparing the Install Location	
Mounting Bracket . . . . .	5
Ductwork . . . . .	5
Static Pressure Testing . . . . .	5
Fans . . . . .	6
Accessories . . . . .	6
Installation	
Installation Elevation . . . . .	7
Mounting Bracket . . . . .	7
Installing Hood onto Mounting Bracket . . . . .	8
Installing the Fan . . . . .	9
Range Element Disconnect Installation	
Gas Disconnect Valve . . . . .	10
Electrical Disconnect Box . . . . .	10
Installing Accessories	
ClockBox . . . . .	11
Remote ADA Switches . . . . .	11
Manual Pull Station . . . . .	11
Ductwork . . . . .	11
Electrical Installation	
Main Control Power . . . . .	12
Electric Disconnect Box . . . . .	13
Gas Disconnect Valve . . . . .	13
Inline/Wall Mount Fan . . . . .	14
ClockBox . . . . .	14
Remote ADA Switches . . . . .	14
Fire Alarm System Connections . . . . .	14
Wiring Diagram . . . . .	15
ClockBox Wiring Diagram . . . . .	16
Operation . . . . .	17
Environmental Monitoring / Pre-Suppression	
Functions . . . . .	17
Accessing the Internal Components . . . . .	18
ClockBox Operation and Navigation . . . . .	19
Test Tank and Demonstration . . . . .	20
Controller Schematic . . . . .	21
Alarm Connections . . . . .	21
Self-Monitoring System . . . . .	22
After an Actuation . . . . .	23
How to Reset the Suppression System . . . . .	23-24
Maintaining the System . . . . .	25
Inspection Procedures	
Nozzle Caps . . . . .	25
Fusible Link System . . . . .	25
10 Year Maintenance . . . . .	25
Lighting . . . . .	25
Removing the Extinguisher Tank . . . . .	26
Service and Recertification Schedule . . . . .	26
Replacement Parts . . . . .	26
Maintenance Log . . . . .	27
Our Commitment . . . . .	28

## Receiving

Upon receiving the product, check to ensure all items are accounted for by referencing the delivery receipt or packing list. Inspect each crate or carton for shipping damage before accepting delivery. Alert the carrier of any damage detected. The customer will make notation of damage (or shortage of items) on the delivery receipt and all copies of the bill of lading which is countersigned by the delivering carrier. If damaged, immediately contact your Greenheck Representative. Any physical damage to the unit after acceptance is not the responsibility of Greenheck Fan Corporation.

## Unpacking

Verify that all required parts and the correct quantity of each item have been received. If any items are missing, report shortages to your local representative to arrange for obtaining missing parts. Confirmation of shipment(s) must be limited to only items on the bill of lading.

## Handling

Handle in such a manner as to keep from scratching or chipping the coating. Damaged finish may reduce ability of unit to resist corrosion.

## Storage

Units are protected against damage during shipment. If the unit cannot be installed and operated immediately, precautions need to be taken to prevent deterioration of the unit during storage. The user assumes responsibility of the unit and accessories while in storage. The manufacturer will not be responsible for damage during storage. These suggestions are provided solely as a convenience to the user.

The ideal environment for the storage of units and accessories is indoors, above grade, in a low humidity atmosphere which is sealed to prevent the entry of blowing dust, rain, or snow. Temperatures should be evenly maintained between 30°F (-1°C) and 110°F (43°C). All accessories must be stored indoors in a clean, dry location.

## Model Number Code

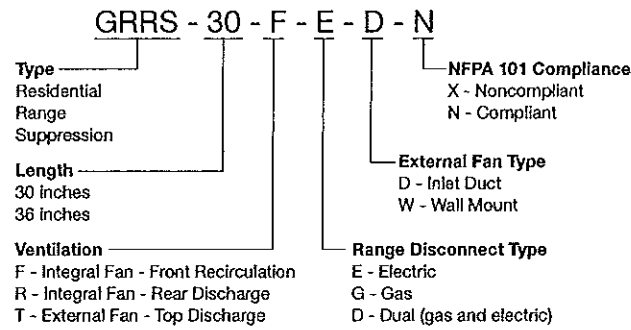

**Example: GRRS-30-F-D-N**  
Greenheck RRS, 30 inches long, with front fan discharge, with dual element disconnect, NFPA 101 Compliant

## Parts Checklist

- Hood
- Back support mounting bracket
- External fan (Inline / Wall Mount / None)
  - 25 ft. plenum rated wire for plug and play connection
- 8 ft. of metal clad wire for hood power connection (marked with red tape)
- Gas disconnect valve (optional)
  - 6 ft. shielded control wire for plug and play connection
- Electrical disconnect box (optional)
  - 6 ft. shielded control wire for plug and play connection
- 8 ft. of metal clad wire for gas disconnect/electrical disconnect connection (marked with black tape)
- Remote switches, ADA (optional)
- Manual Pull Kit (optional) consisting of the following:
  - Pull Box (1)
  - Pull Face (1)
  - Elbow Pulley (3)
  - 25 ft. Cable and Pin
- The ClockBox (optional)
  - 20 ft. shielded control wire for plug and play connection

## Exploded View

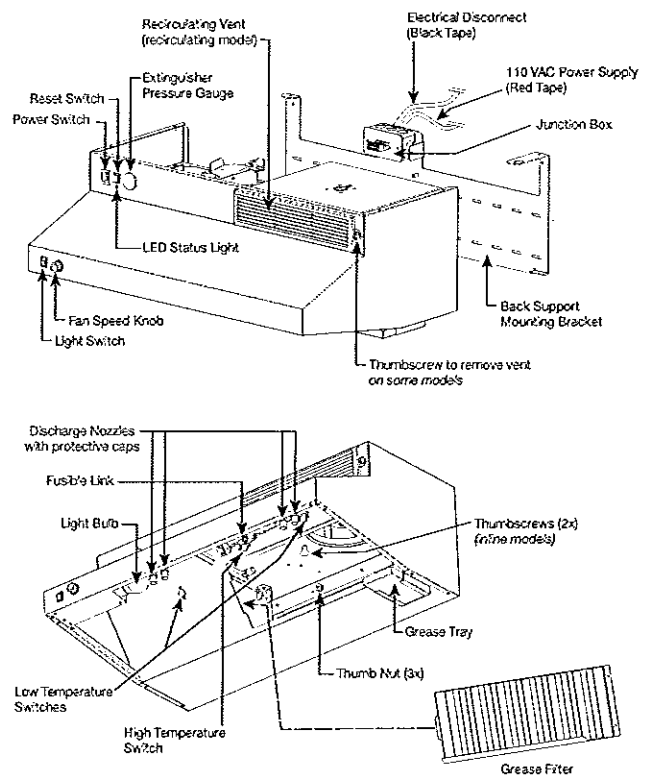

# Sample Installations

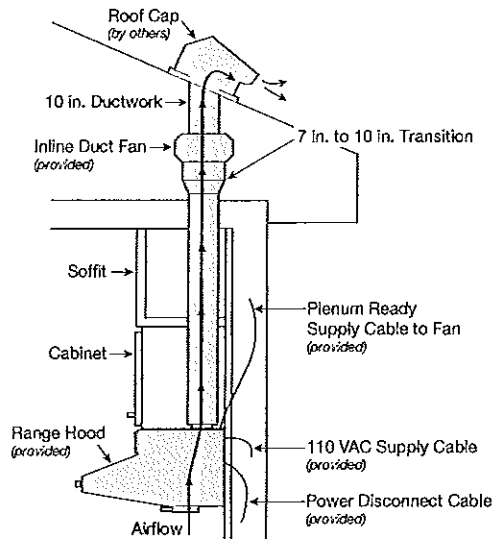

**External Fan | Inline Fan**

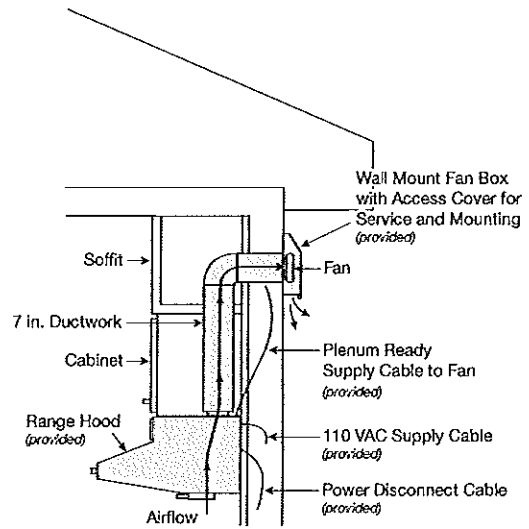

**External Fan | Wall Mount Fan**

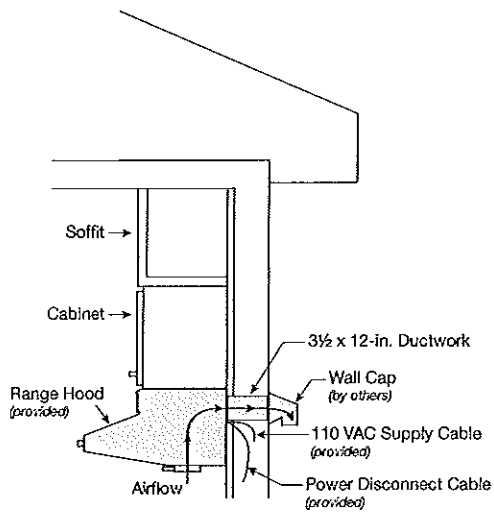

**Integral Fan | Rear Discharge**

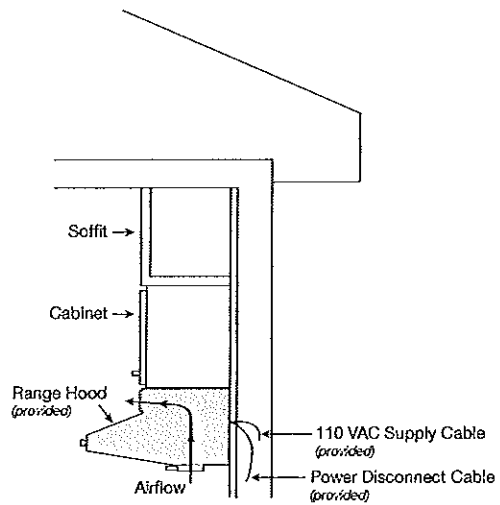

**Integral Fan | Front Recirculation**

## Preparing the Install Location

**Mounting Bracket** - The mounting bracket and hood must be centered over the range. If the range is not in place, the center marking should be relative to its final position. Refer to page 7 for bracket mounting points, rear access holes and access points.

**Ductwork** - The ductwork and fittings used for outside venting (if applicable) must be carefully selected to ensure that the static pressure is in line with the fan parameters. The table below displays maximum duct length allowed for the various fan options.

Hood Width	NFPA 101 Compliance	Fan Type	Venting	CFM (at hood)	Duct Length (maximum)
30 inches	No	Internal	Front (recirculating)	140	Not applicable
	No	Internal	Rear Discharge	250	Not applicable
	No	Inline Duct Fan	Vertical Duct	470	35 feet
	No	Exterior Wall Fan	Vertical Duct	150	20 feet
	Yes	Internal	Front (recirculating)	500	Not applicable
	Yes	Internal	Rear Discharge	500	Not applicable
	Yes	Inline Duct Fan	Vertical Duct	510	35 feet
	Yes	Exterior Wall Fan	Vertical Duct	550	20 feet
36 inches	No	Internal	Front (recirculating)	140	Not applicable
	No	Internal	Rear Discharge	250	Not applicable
	No	Inline Duct Fan	Vertical Duct	470	35 feet
	No	Exterior Wall Fan	Vertical Duct	150	20 feet
	Yes	Internal	Front (recirculating)	500	Not applicable
	Yes	Internal	Rear Discharge	500	Not applicable
	Yes	Inline Duct Fan	Vertical Duct	510	35 feet
	Yes	Exterior Wall Fan	Vertical Duct	550	20 feet

Maximum duct length equals horizontal and vertical duct runs plus duct components such as fittings, elbows, and transitions.

For installations requiring vertical duct venting to an inline fan and NFPA 101 compliance, the hood should be adapted from a 7-inch round duct access hole to a minimum 12-inch duct.

For installations requiring vertical duct venting to an inline fan and NFPA 101 compliance is NOT required, the hood can be adapted to a minimum 10-inch duct.

### WARNING

The amount of fittings and ductwork directly affects the resistance or static pressure placed on the system. If the system is not within the proper static pressure range, the heat sensors and controls will be adversely affected and will impact the proper function of the safety controls. Therefore it is required that airflow testing be recorded along with installation documentation. The air testing is accessed by the removal of the grease tray and measured with an airflow pressure gauge.

**Static Pressure Testing** - The magnehelic gauge test port opening is located beneath the grease tray. The static pressure needs to be measured to ensure airflows meet design criteria. The airflow is measured by attaching the gauge tubing to the magnehelic gauge inlet, and the hood fitting is attached to the grease drain hole beneath the grease tray.

A reading of 0.45 to 0.85 inches wg. is required to meet design standards. This reading will correspond to the static pressure of the ductwork, hood and fan combination.

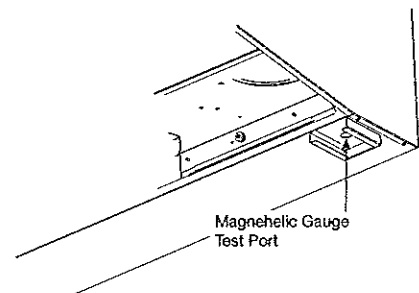

## Fans

For inline fans and exterior wall fans, fan location and proper mounting will be required.

If the hood system is configured for front recirculation discharge or rear discharge and NFPA 101 compliance, the unit will come equipped with a fan box. If installing under cabinets, keeping the fan box flush to the underside of cabinet will guarantee correct spacing. Otherwise, center and mark the installation area according to wall mounting bracket prior to hanging.

The following steps will be required.

1. Insert/attach the top portion of the manual pull kit conduit through the fan box.

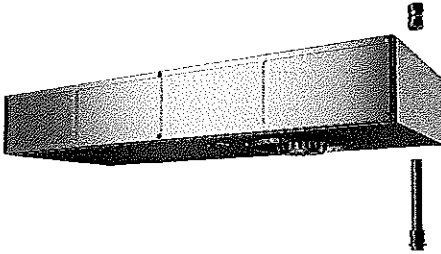

2. Attach square duct collar to the bottom of the fan box with included hardware.

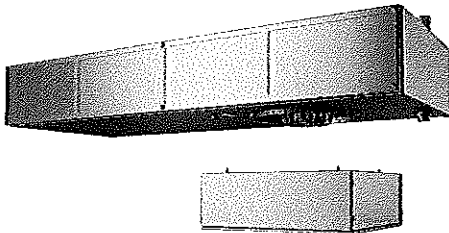

3. Attach the fan box to the mounting bracket with included 8/32 nuts, then complete the installation on the manual pull kit conduit and top/bottom unions.

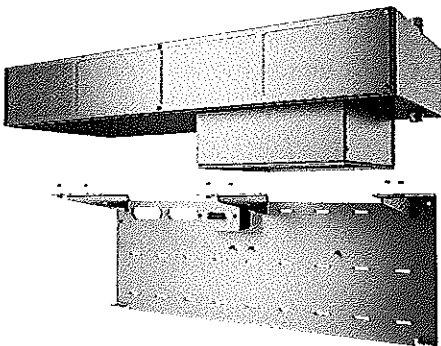

When prepping a space for installation, a 4- $\frac{5}{16}$  inch space must be allowed between the top of the mounting bracket and the bottom of the cabinet for the fan box. The additional height of the unit should not result in reduced range clearance. Cabinets should be installed approximately 5 inches higher to accommodate the additional size of the NFPA 101 fan box assembly.

## Accessories

Location restrictions will apply if the hood system supplied is provided with any of the optional accessories:

- ClockBox
- Remote ADA Switches
- Manual Pull Station

# Installation

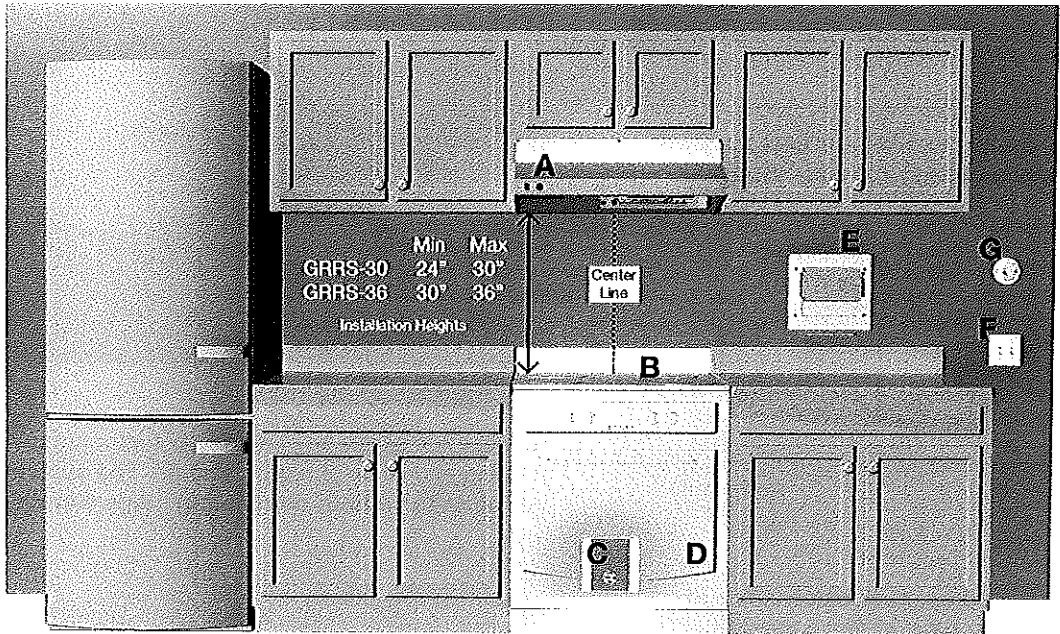

## Installation Elevation

- A. Hood (30 or 36 inches)
- B. Appliance (for reference purposes)
- C. Range Disconnect - electric, gas or dual (optional)
- D. Gas Range Element Disconnect (not shown)
- E. The ClockBox. Range Element Time-Out System (optional)
- F. Handicapped Accessible Control Box (optional)
- G. Manual Pull Station (optional)

## Mounting Bracket for a 30-inch unit

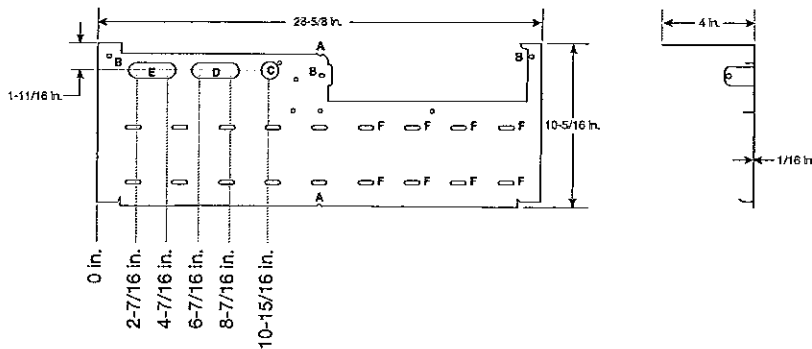

## Mounting Bracket

- A. Center notches
- B. Critical mounting points must be secured to studs or drywall hangers.
- C. Rear access to junction box connection
- D. Primary access point for connections to junction box
- E. Secondary access point for connections to hood (options/ accessories)
- F. Additional mounting points. Secure minimum of three (3) screws per row.

## Mounting Bracket for NFPA Installation

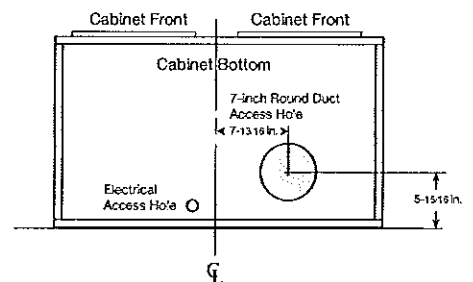
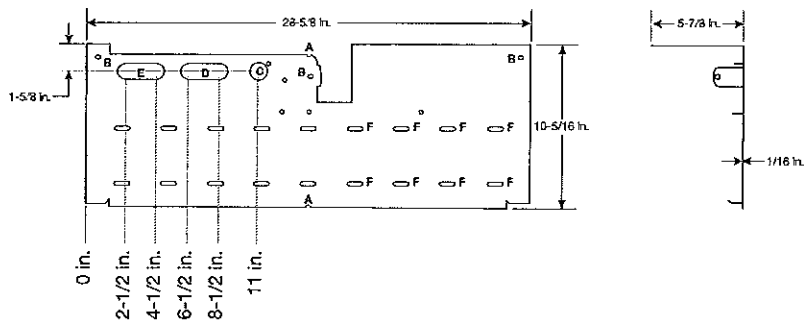

## Installing Hood onto Mounting Bracket

### NOTE

Install manual pull station, if provided, before arming the system.

1. Lift hood onto mounting bracket and seat the lower tabs of the mounting bracket into slots in back of hood.

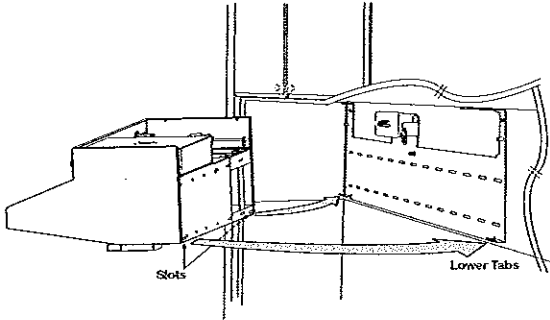

2. While holding the hood up, hook safety cable to chain link on mounting bracket and screw nut to close the link. The hood is now in the service position.

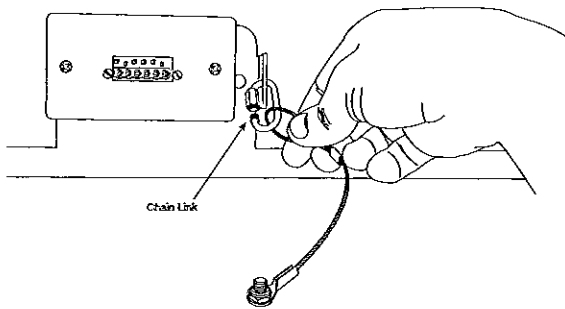

3. Connect male plug from top of hood into female plug mounted in junction box.

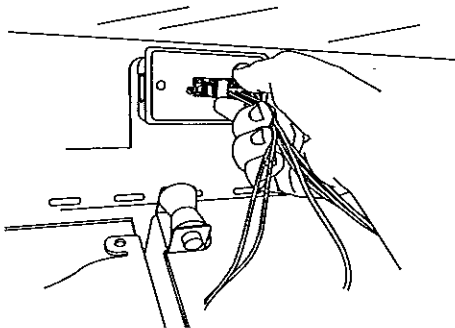

4. Remove the safety pin - identified with the yellow CAUTION flag from the trigger on top of the extinguisher bottle.

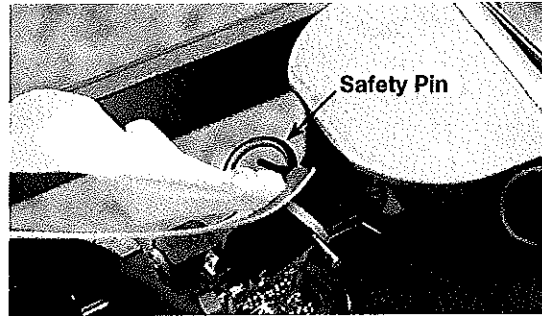

5. Remove the safety key from the actuator arm by rotating and lifting straight upwards. The system will not actuate without completing steps 4 and 5.

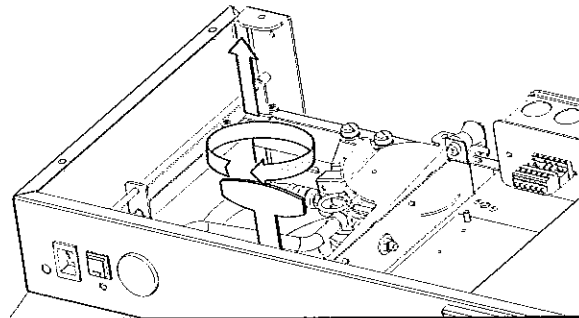

### CAUTION

The system is now armed.

6. Rotate hood to wall and thread the three thumb nuts to the bolts in the mounting plate. Check page 18 for location of thumb nuts.

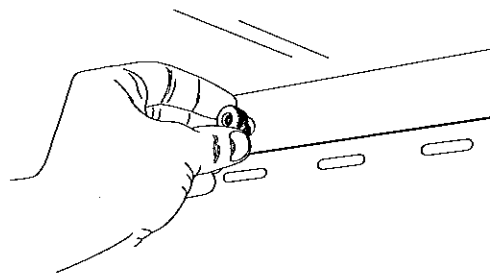



## Installing Fan (if applicable)

### Inline

Install fan vertically in ductwork running between the unit and roof cap.

For best results, use as few elbows or transitions as possible. If necessary, long radius elbows or bends are recommended.

To attach ductwork, use duct tape at inlet and outlet to assure a good seal. If using fan clamps, attach clamps and insert screws through clamp into inlet and outlet flanges.

### CAUTION

Use sheet metal screws to secure ductwork to inlet and outlet. It is critical that the screw penetrate the metal of the flange, but not so far as to bind the impeller. It may be necessary to angle screws away from impeller.

### Inline Exhaust Fan - NFPA

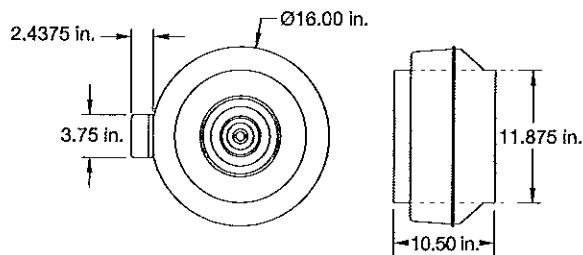

### Inline Exhaust Fan - Non-NFPA

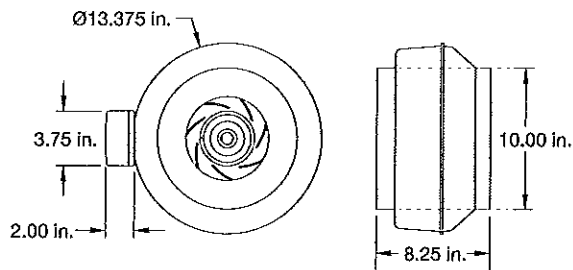

### Wall Mounted Fan

Fasten the fan box to an external wall via the four 0.27-inch mounting holes.

Run electrical through the 0.81-inch hole towards the top right corner of the box.

Attach ductwork using duct sealant, caulk, or tape to all seams to prevent air leakage and maximize air performance.

For best results use as few elbows or transitions as possible. If necessary, long radius elbows or bends are recommended.

### Wall Fan - NFPA

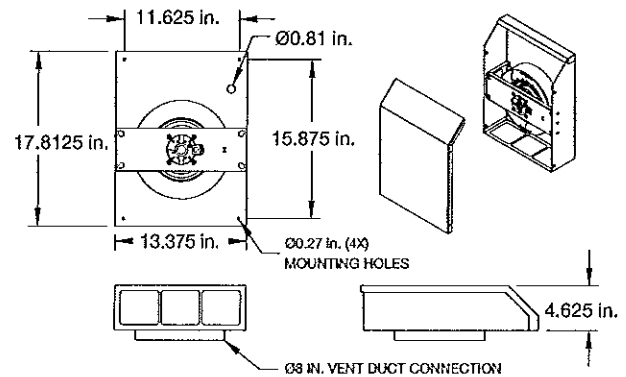

### Wall Fan - Non-NFPA

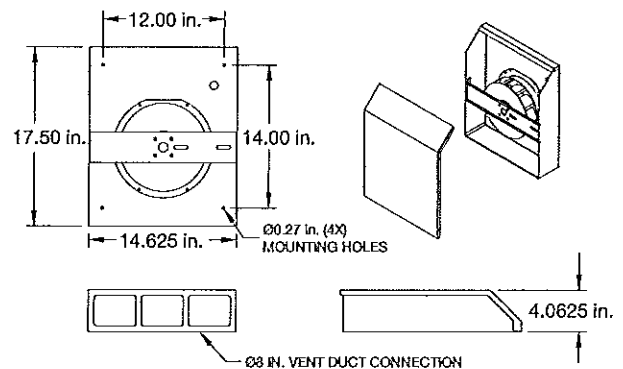

## Range Element Disconnect Installation

### Gas Disconnect Valve (if applicable)

The gas solenoid is designed for use with 3/4-inch NPT pipe. Be sure to note the "IN" and "OUT" ends of the solenoid body (as marked on the body). This determines direction of gas flow. Refer to wiring diagram on pages 13 and 15 for details on electrical connection.

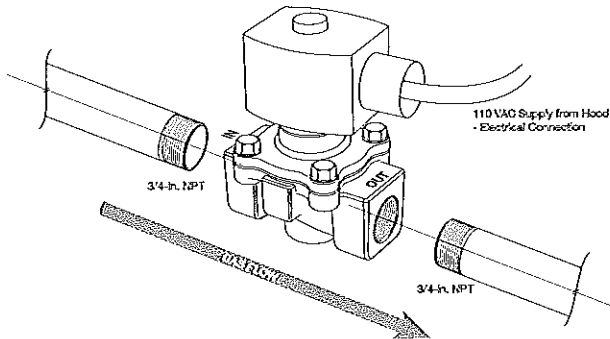

### Electrical Disconnect Box (if applicable)

1. Cut a hole in the drywall for the relay box; refer to the submittal for dimensions. Be sure to note the 1-1/4 inch overhang on each side of the face plate. Given this, the hole should be about 6-3/8 by 8-3/4 inch. The relay box has been designed to fit in a standard 2x4 studded wall.

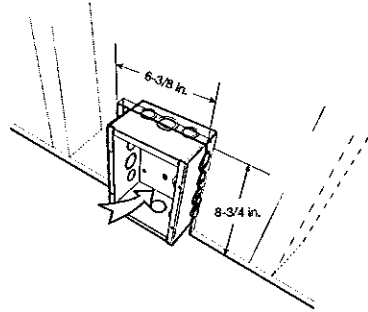

2. If you haven't already done so, run wiring from the junction box location (on the unit mounting plate) to the power disconnect box location and string through one of the knockouts in the box.

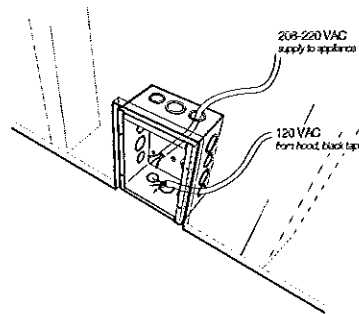

3. Make all wiring connections and secure face plate to box in wall. Wiring information is provided on pages 13 and 15.

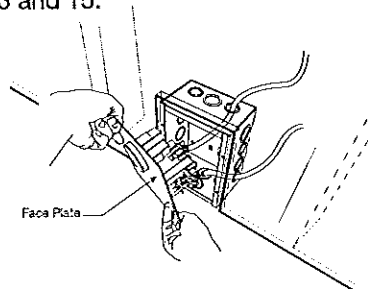

## Installing Accessories

Refer to your submittal for installation dimensions of these accessories.

### ClockBox (optional)

The ClockBox works by controlling the cooking element (gas, electric and dual element ranges) and minimizes the likelihood of an unattended cooking fire. The system disables the cooking element until the operator unlocks the cover and presses the GO button. After two hours the cooking element is automatically disabled.

If this unit was provided with the ClockBox, a ClockBox controller and Touchscreen user-interface will be provided. Both will need to be remotely mounted near the appliance (range) on a nearby wall.

### Remote ADA Switches (optional)

If the unit is provided with the remote ADA switches, these will have to be installed to be in compliance with ADA standards for Accessible Design.

### Manual Pull Station Installation (optional)

If the unit is provided with the remote ADA switches, these will have to be installed to be in compliance with ADA standards for Accessible Design.

Parts included in the kit:

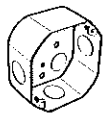

Pull Box (x1)

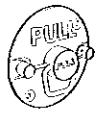

Pull Face (x1)



Elbow Pulley (x3)



Cable and Pin (25 ft)

### Step 1: Installing Conduit

Mount the pull box in an appropriate location according to local building codes. Keep in mind you are supplied with 25 feet of cable and three (3) elbow pulleys. Install 1/2 inch conduit (not included) between the unit and the pull box, using the pulleys as needed. Pull cable through the conduit, and allow 8 to 12 inches of slack to be left at the hood unit end. Be sure to abide by all local building codes when installing conduit.

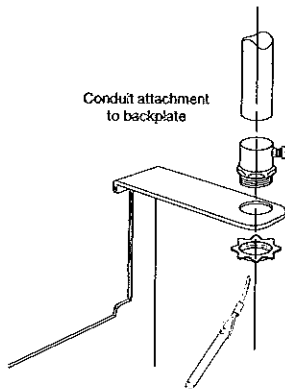

### Step 2: Replace Safety Pin and Key (to prevent accidental discharge)

With the unit lowered into its service position, put the safety pin in its slot at the top of the extinguisher tank. Also replace the safety key in its slot in the actuator arm. Then remove the cable from the actuator arm.

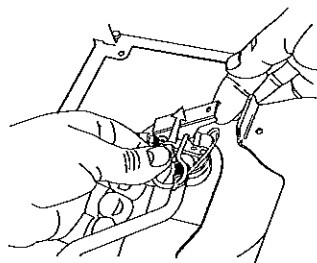

### Step 3: Install Cable and Pin to hood

Thread the cable through the conduit, with the pin reaching the unit. Remove the grease filter. In the upper right corner, find the two pulleys as illustrated. Hold the rear-most pulley in place. From the top of the unit, replace its pin with the one on the cable. Push the pin through the pulley until you hear it click in place. Go back to the actuator arm and rehook cable onto the arm.

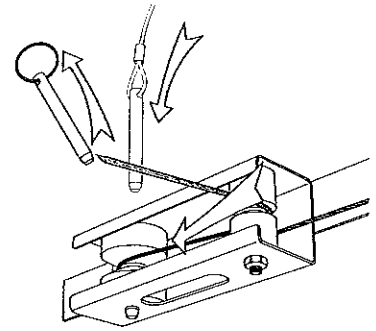

### WARNING

You must allow for 8 to 12 inches of slack in the cable to sit at the pull face. Failure to do so will cause the unit to discharge the next time the unit is lowered into its service position.

### CAUTION

Make sure the cable does not become caught on any part of the hood or conduit, or the cable will not be able to be pulled, and the unit will not discharge.

### Step 4: Install Cable to Pull Face

With the unit in its lowered position, attach the cable to the pull face by crimping a loop in the cable through the hole on the back side of the handle. Be sure cable is securely crimped to withstand at least 50 lbs.

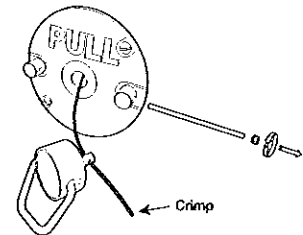

of pull force. Leave no more than 12 inches of slack in the line on the pull face end, but maintain 8 to 12 inches. To make this easier, the handle may be removed by loosening the set screw in one of the studs, and sliding the red plastic rod out. Attach the pull face to the pull box already mounted on the wall, collecting any slack into the pull box. Do not allow slack cable to collect above the hood.

### Installing Ductwork (optional)

Ductwork will need to be provided and installed if the unit was provided with an external fan.

Installation work must be done by qualified person(s) in accordance with all applicable codes and standards, including fire-rated construction.

To minimize static pressure losses and promote adequate airflow, minimize duct run lengths where possible.

## Electrical Installation

### Main Control Power

1. Determine mounting location of the appliance disconnect (contactor box and/or gas valve) and mounting bracket, if not already done.
2. Run factory-provided wire from junction box through the wall to the appliance disconnect, unless ClockBox option is provided. For electrical installation information regarding the ClockBox, refer to page 16. Wire the factory-provided 110 VAC main power connection to a 15 amp rated circuit.
3. If the hood unit is to be linked to a fire alarm system, accommodations for those wires will need to be made at this time as well. Refer to fire alarm electrical installation information on page 14.

### CAUTION

Electrical installation should be performed by a licensed electrician. Installation should be performed according to all applicable codes and regulations. Shut off power at the main breaker to prevent electrical shock when accessing electrical connections. All field installation and wiring of electrical equipment must be done to meet NEC and local codes

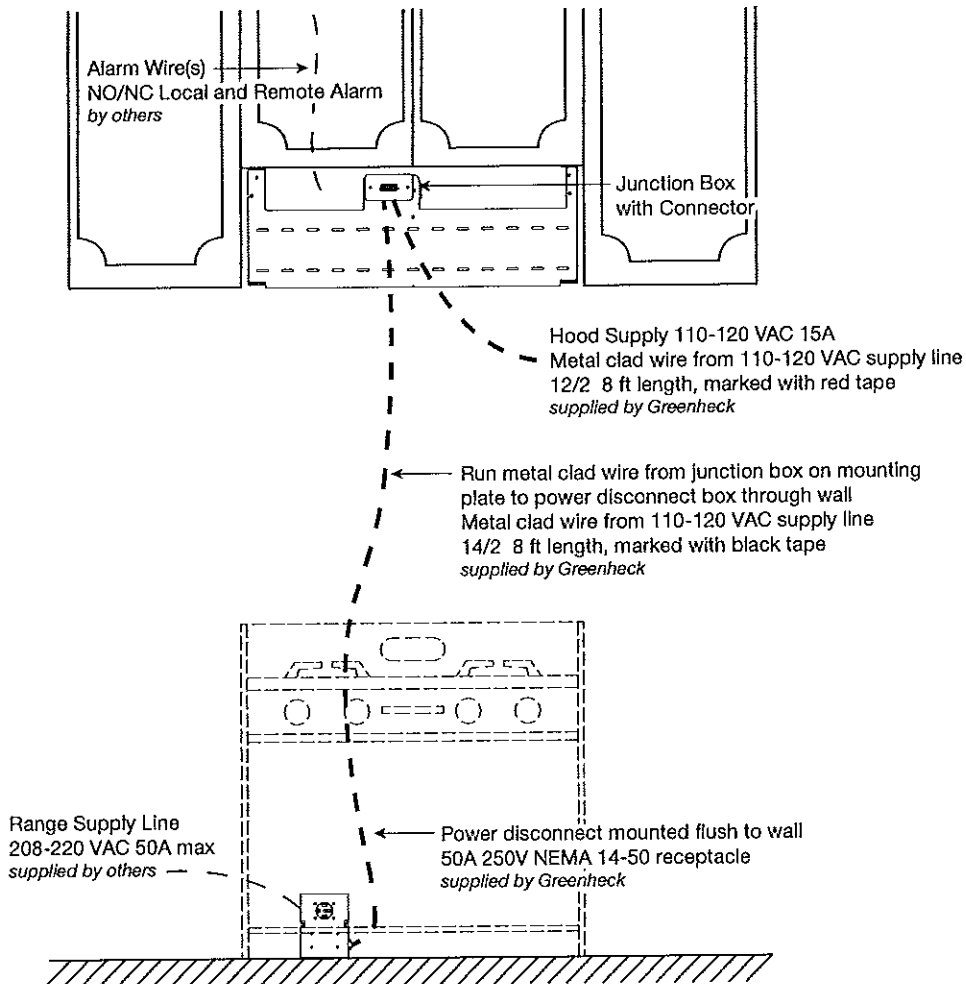

### Electric Disconnect Box (if applicable)

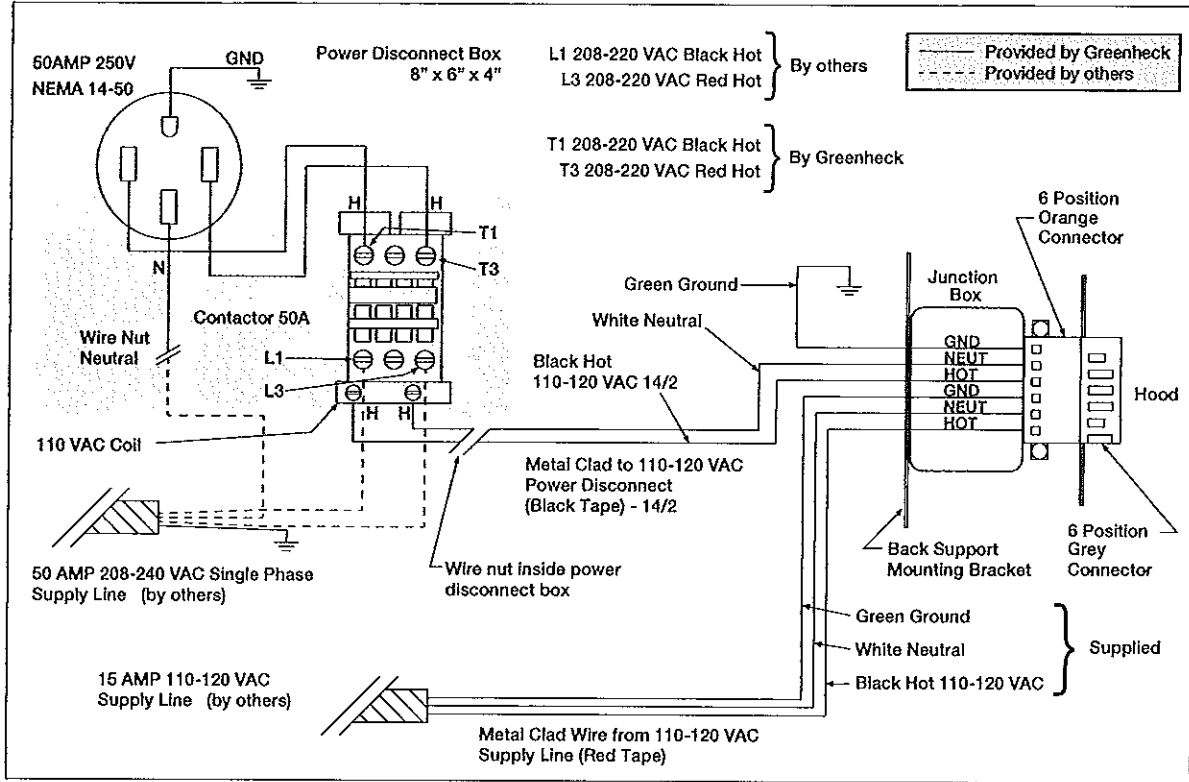

### Gas Disconnect Valve (if applicable)

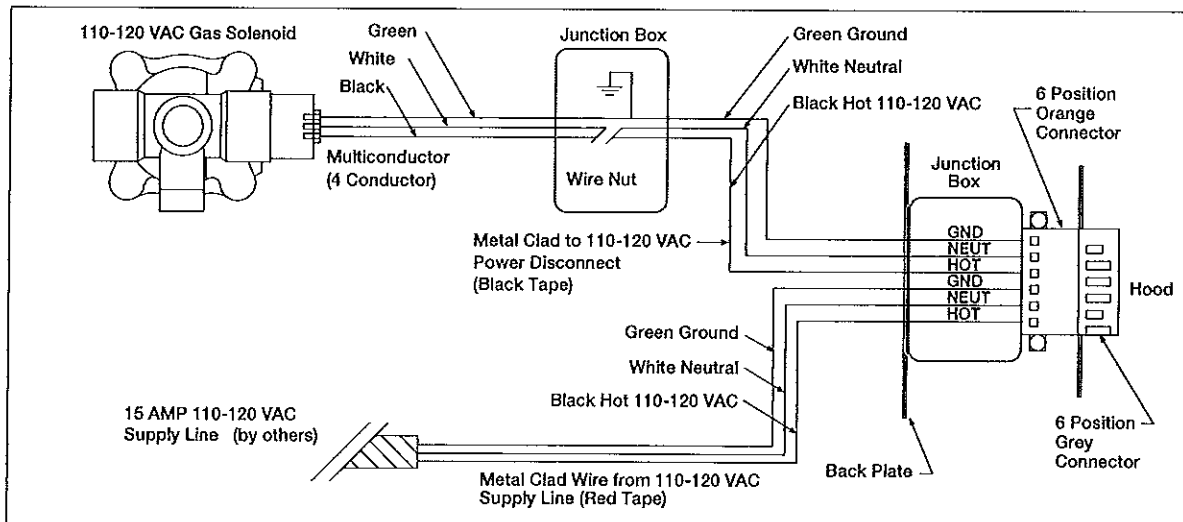

### Inline/Wall Mount Fan Power (if applicable)

Twenty-five (25) feet of plenum rated wire is provided with both the inline fan and wall mounted fan option. The fan needs to be connected with the provided connector within the hood controls. See wiring diagram on page 15 for wiring information.

### ClockBox (if applicable)

Twenty (20) feet of shielded control wire is provided with the ClockBox option to connect the ClockBox controller to the touchscreen interface. The ClockBox needs to be connected back via the connector within hood controls. See wiring diagram on page 15 for wiring information.

### Remote ADA Switches (if applicable)

Eight (8) feet of shielded control wire is provided with the ADA remote switch option. The switches need to be connected back with the provided connector within the hood controls. See wiring diagram on page 15 for wiring information.

### Fire Alarm System Connections

The hood unit has two fire alarm connections (discrete switches), each with its own trigger. A connection is made to one output (Y#) and one common (C#) at the controller. The output labeled Y0 is triggered by a fault from the high temperature switch (190°F), or pressure switch, or hose switch. Output Y1 is triggered by a high temperature switch (190°F) and a low pressure fault in the extinguisher tank (the fire suppressant has discharged). You may use either one connection or both, depending on your situation. When there is a fault, a buzzer in the unit will sound and the power disconnect will turn off.

**Local Alarm Connection:** Connect to output Y0 and common C0

**Remote Alarm Connection:** Connect to output Y1 and common C1

To connect to the alarms, it is preferred that you use a spade terminal connector (supplied), but a stripped wire is acceptable.

Connecting the alarm system in the configuration described above results in a normally open connection.

To switch these two alarm contacts to normally closed connections, insert a jumper into the blue and the gray terminal adjacent to it (**terminal blocks 4 and 5**). One leg of the provided jumper is inserted into the blue terminal and the other into the gray terminal.

#### NOTE

Ensure jumper is inserted completely and the top of the jumper is level with the other jumpers.

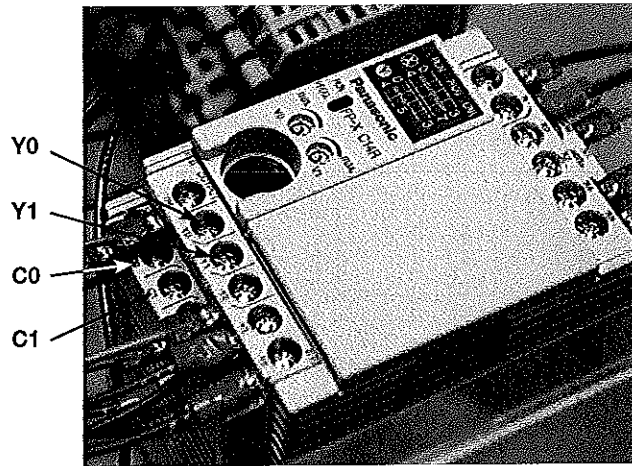

Onboard Controller

In addition to the fire alarm system connections described previously, a second connection may be made to the fire alarm switch installed in the unit. Unlike the connection above, this switch does not require power to be fed to the hood in order to function. The fire alarm switch is located above the actuator arm, beside the controller assembly. The fire alarm switch is activated when the actuator arm trips.

To connect the fire alarm switch, wire the fire alarm to the common connector and normally open or normally closed connection as shown.

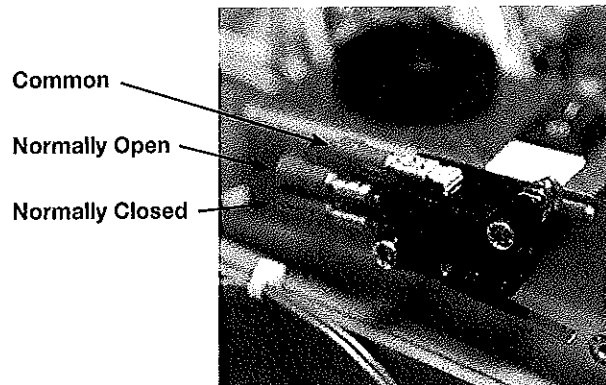

Fire Alarm Switch

# Wiring Diagram

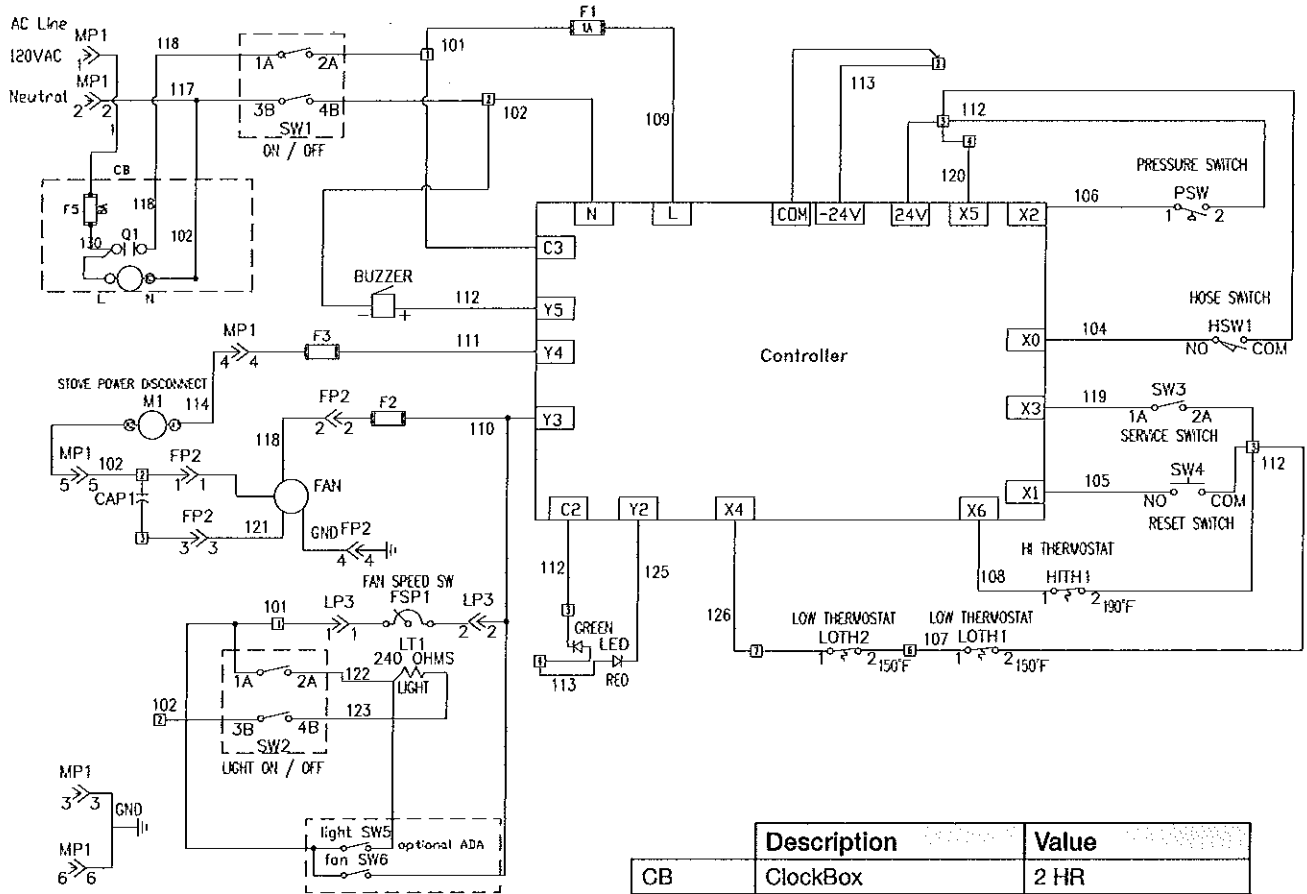

	Description	Value
CB	ClockBox	2 HR
F1	Controller Fuse	1 AMP Fast Blow
F2	Fan Fuse	2 AMP Slow Blow
F3	Dual Disconnect	1 AMP Slow Blow
F3	Disconnect Fuse	0.5 AMP Slow Blow
F4	Main Fuse	8 AMP Slow Blow
F5	ClockBox Fuse	8 AMP Slow Blow
MP1	Main Power Connector	
FP2	Fan Connector	
SW1	Main Power Switch	
SW2	Light Switch	
SW3	Service Switch	
SW4	Reset Switch	
SW5	Optional ADA Light	
SW6	Optional ADA Fan	
HSW1	Hose Switch	
HITH1	High Temp Thermostat	190°F
LOTH1,2	Low Temp Thermostat	150°F
FSP1	Fan Speed Controller	4.0 FLA
FAN	Inline or Recirc Fan	
CAP1	Capacitor for Recirc Fan	10 UF
M1	Stove Disconnect	40 FLA 50 A RES
LIGHT	Hood Light	60 WATT
Controller	Computer Driving Hood	
BUZZER	Alarm in Hood	90 DB

## ClockBox Wiring Diagram (if applicable)

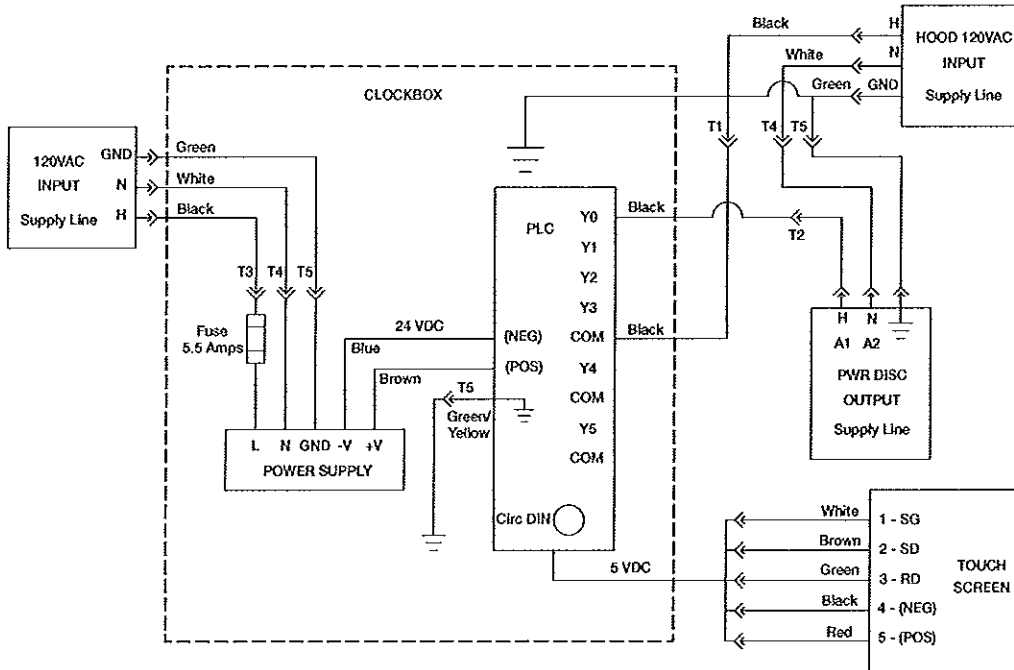

1. An independent 110 VAC supply line is provided to the ClockBox.
  - a. This supply line provides power to the ClockBox, which is independent from the supply line to the hood.
2. The ClockBox provides 110 VAC to the Power Disconnect Assembly
3. The ClockBox provides control signal voltage (5VDC) and logic control to the Touchscreen [HMI]
4. The Power Disconnect Assembly supplies the input line to the stove/range as follows:
  - a. If an **Electric Disconnect**
    - Controls the 110 VAC contactor coil allowing the 220 VAC supply line to the stove/range via the NEMA 14-50 receptacle.
  - b. If a **Gas Disconnect**
    - Open the solenoid valve allowing gas to flow to the input line of the stove/range
  - c. If **Dual Disconnect**
    - Both conditions 6.a.i and 6.b.i will apply
  - d. The above reference will be maintained for as long as there is time left at the ClockBox, it will open the contact in the timer, stopping the supply line to the Power Disconnect, which in turn, will shut off the stove.

## ClockBox System Interface Diagram

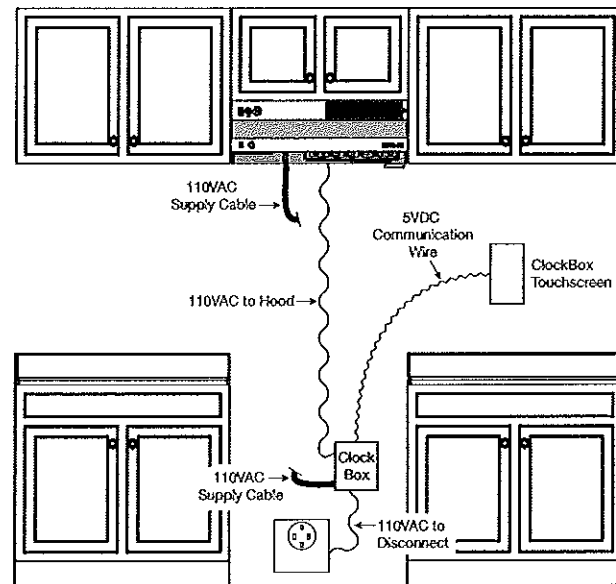

### NOTE

Some electric stoves/ranges have a warning light to alert the user that the burners/coils are hot. These warning lights will be off since the supply line powering the stove/range is not present.



## Operation - How it Works

The GRRS functions as a standard ventilation range hood with the added capability to suppress stove top fires.

Designed for use over a standard 30 and 36 inch residential range, it uses a mechanical, commercial style automatic fire suppression system.

Refer to the illustration below to familiarize yourself with the following functions.

- A controller provides an internal alarm plus connections for up to two external alarms that may go to a local alarm panel and/or remote location, i.e. the local fire department.
- The unit is powered from standard 115 VAC / 60 Hz / single phase. A main Power Switch is located at the upper left of the front surface. (Remote ADA switches provided).
- For normal daily use, the unit provides a fan speed control knob and a light switch for the light.
- A Reset Button (white) is provided to energize the controller and the main power disconnect contactor (electric range) or valve (gas stove). Upon initial power up, the control system is not enabled and this reset button needs to be pressed. In doing so the Status LED below the reset switch will turn from red to green.

## Environmental Monitoring / Pre-Suppression Functions

The controller operating system is designed to enhance the functionality of the unit and the safety of the cooking environment.

The system relies on input from a set of thermostats to control the fan and shutoff power to the stove when the temperature reaches preset points.

As the temperature rises, the controller monitors the environment with the three (3) thermostats. The board is programmed to respond to two temperature thresholds. The first at 150°F and the second at 190°F.

At the first temperature threshold of 150°F, the ventilation fan will turn on, **regardless of the front panel switch setting.**

At the second temperature threshold of 190°F:

1. The power disconnect to the stove (valve or contactor) is de-energized, shutting off power to the stove.
2. The "local" alarm output is tripped, indicating a trouble condition with the unit. This output is from contacts C0 and Y0 on the controller.
3. The on-board audible alarm sounds (high pitched tone).

### NOTE

See page 21 for controller schematic.

## Accessing the Internal Components

Moving the unit between 'operating' and 'service' positions.

All GRRS models have been configured as a stand alone unit mounted to a wall plate. As such, the unit may easily be tilted down into a service position, giving you access to the electronics and extinguisher tank, or be removed completely for maintenance and cleaning. Provisions have been made to facilitate easy removal including a minimal amount of fasteners and modular electrical connections.

To place the unit in the service position, a few simple steps are required. Be sure to wear safety glasses at all times during this process:

1. Shut the unit off with the power switch on the front of the hood.
2. Remove the grease tray and the grease entrapment filter.
3. For **non-ducted installation**, loosen and remove the thumb nuts that are on the rear inside wall of fan housing compartment.

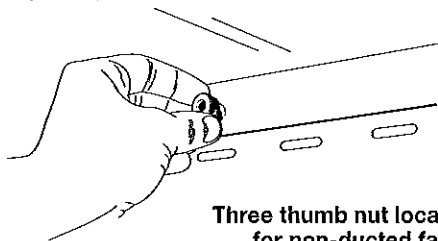

Three thumb nut locations for non-ducted fan

On **ducted installations**, remove the two thumb nuts located at the top inside near the fan intake. Slowly lower the unit.



Thumb nut locations for ducted fan only

4. The unit will now freely pivot downward to a stop position. A safety cable is provided to prevent the unit from falling or lowering too far.
5. Place safety pin in the tank valve to avoid accidental discharge.

With the unit in this position, basic servicing and cleaning may be performed, including servicing the extinguisher tank assembly.

To move the unit back to the operating position, simply reverse the process as outlined above.

## CAUTION

- Be careful while working with the unit in the service position. Release of the cable system or applying force to the tank valve assembly may cause discharge of the tank. The high pressure discharge has the potential to cause skin or eye damage and injury!
- An electrical shock hazard is present at the electrical compartment whenever there is power to the hood. Use caution when working around this device while the unit has power.

# ClockBox Operation and Navigation (if applicable)

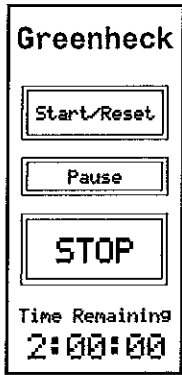

Figure 1

FIGURE 1

1. Press **Start/Reset** to allow the 2 hour timer to begin. This will prompt to the password screen. See Figure 2.
2. Press **Pause** to pause the timer, press again to continue.
3. Press **STOP** to stop the timer.
4. If the timer is running, pressing the **Start/Reset** button will reset the timer at the original timer value and start running the timer again.
5. The Greenheck logo is a hidden button which allows access to background menus. Press the **Greenheck** logo to access hidden menu to modify timer values and passwords. See Figure 3.

**NOTE:** Main Screen will always show available time. System is pre-set to countdown remaining time.

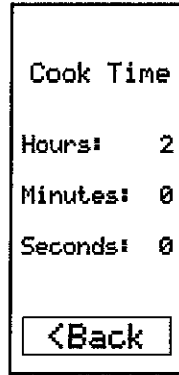

Figure 4

FIGURE 4

1. To adjust hours, minutes, or seconds of cook timer, press on respective number. Enter the new value and press enter symbol (↵) to store the value.

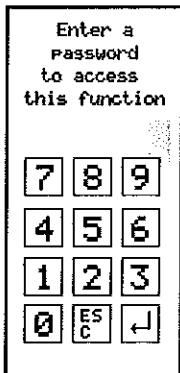

Figure 2

FIGURE 2

1. Factory preset master password: 06412
2. Enter password 06412 and then press the enter symbol (↵).

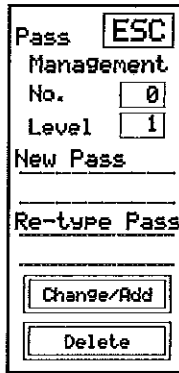

Figure 5

FIGURE 5

1. Adjust password number and level. Press under **New Pass** to key new password. To validate the password, re-type the password under **Re-Type Pass**. Press the **Change/Add** key to add or adjust a password or **Delete** to omit a stored password.

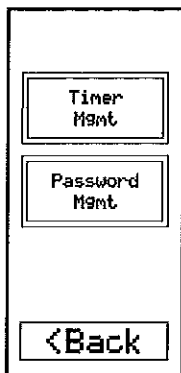

Figure 3

FIGURE 3

1. Press **Timer Mgmt** to modify the timer value. See Figure 4 for timer management screen.
2. Press **Password Mgmt** to add/modify/delete passwords. See Figure 5 for password management screen.

## Test Tank and Demonstration

Once the hood has been installed, it may be necessary or desired to test the unit with a test tank filled with pressurized nitrogen (optional).

1. Following the "Removing the Extinguisher Tank" instructions on page 25, remove the extinguisher tank and replace it with a test tank.

### WARNING

The safety pin must be in place in the extinguisher tank until the unit is ready to be returned to service or to be tested. **Always wear safety glasses during this procedure.**

2. The unit can be actuated one of two ways:

#### A. Cut Test Links

Replace the actuator arm's safety key. Loosen the turnbuckle in the fusible link cable assembly (underside of hood). Replace one of the fusible links with a test link. Retighten the turnbuckle to the proper tension. Remove the safety key and raise the unit to its operational position. To test, cut the test link with wire cutters or similar.

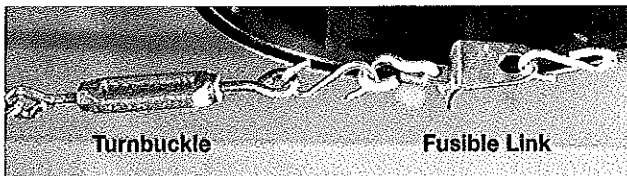
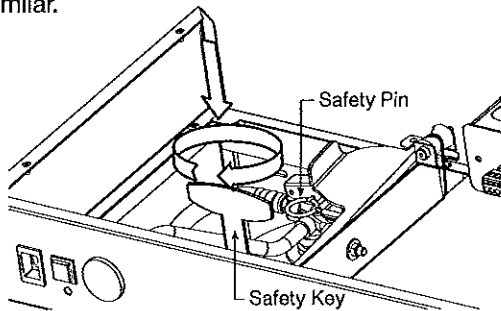

#### B. Manual Pull Kit (if installed)

Raise the unit to its operational position after the test tank has been installed. Remove the plastic break rod from the pull face with an allen wrench (refer to manual pull station appendix for more detailed information on this). Pull the handle to actuate the unit. Refer to the "Manual Pull Kit" section on the method to return the pull station to an operational state.

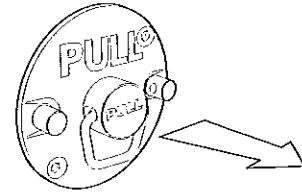

3. Nitrogen should be released from each nozzle simultaneously.

### WARNING

Be careful of the protective caps on the nozzles. These will fly off the nozzles when the unit is actuated. **Always wear safety glasses during this procedure.**

4. Replace the test tank with the extinguisher tank, the test link with a fusible link, and place the unit to its operational position. The unit is now ready to be put into service.

# Controller Schematic

On the controller, there are two rows of LED indicators next to the X (inputs) and two rows of LED's on the Y area (outputs).

LED Label	Input Function	Scenario	LED State
X0	Hose Switch	Hose in place	On
		Hose disconnected	Off
X1	Reset Switch	When switch is depressed	On
		Switch not pressed	Off
X2	Pressure Switch	Pressure okay	On
		Pressure failure	Off
X3	Service Switch	Servicing unit	On
		Normal operation	Off
X4	Low Temperature Switch	Both low temp thermostats below 150°F	On
		Either thermostat at or above 150°F	Off
X5	Remote and Local Alarms	Alarms are configured for normally closed (jumper installed)	On
		Alarms are configured for normally open (no jumper)	Off
X6	High Temperature Switch	High temperature thermostat below 190°F	On
		High temperature thermostat at or above 190°F	Off

LED Label	Output Function	Scenario	LED State
Y0	Output for Local Alarm	Low gas switch activates OR hose switch activates OR high temperature switch activates	On*
		Normal operation	Off*
Y1	Output for Remote Alarm	Loss of pressure AND high temperature (fire suppression discharge)	On*
		Normal Operation	Off*
Y2	Normal Condition	Alarm condition	On
		Normal condition	Off
Y3	Fan	When controller turns the fan on	On
		When controller is not running the fan	Off
Y4	Power Disconnect	When power is being set to gas/electric disconnect (normal operation)	On
		When power is lost to gas/electric disconnect	Off
Y5	Horn	Horn is on	On
		Horn is off	Off

\*The LED's state depends on whether the alarm contacts are set up for normally open or normally closed. These contacts are set up for normally open from the factory (LED's illuminate during alarm). To configure the fire contacts for normally closed state (LED's illuminate on no alarm), a jumper must be placed between two terminals. Please see page 14 for additional information.

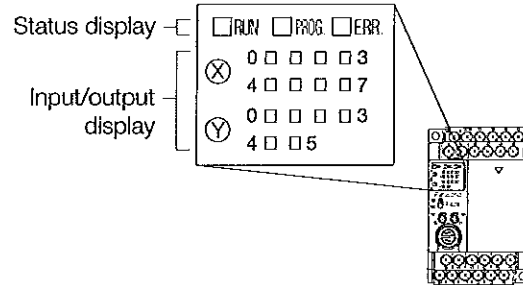

The controller's operating system is designed to enhance the functionality of the unit and the safety of the cooking environment.

## Alarm Connections

**Alarm Outputs:** The other function of the controller is to report alarms from the system either for a system fault or as a result of a system discharge. Refer to Fire Alarm System Connections on page 14 in this installation manual for information on how to connect the alarm outputs.

Output Y1 and common C1 are configured to close with the discharge of the extinguisher tank. This condition is determined by the controller with the low pressure input from the switch and a high temperature condition from the 190°F rated thermostat. Both conditions must be present in order for this output to trigger.

Note that the microswitch outputs are dry contact type, rated for low voltage, and can be normally open (NO) or normally closed (NC), with a common. Therefore do not produce any current or voltage output.

### NOTE

Pressing the reset button will not turn off alarm. Unit needs to be recharged to reset alarm.

**Service Switch:** The black switch next to the controller and internal audible alarm is the service switch. It can be switched on or off. When it is switched to on, the remote alarm and local alarm are deactivated. Its purpose is to allow service to be conducted and components tested without setting off the alarm. Once testing or service is done, turn the service switch to off for normal operation.

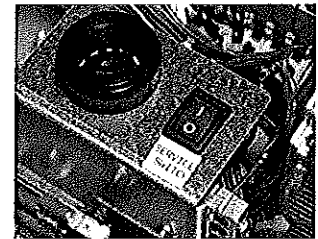

Service Switch in the OFF position

NOTE: LED will flash orange and green.

## Self-Monitoring System

These functions are to be checked at start-up.

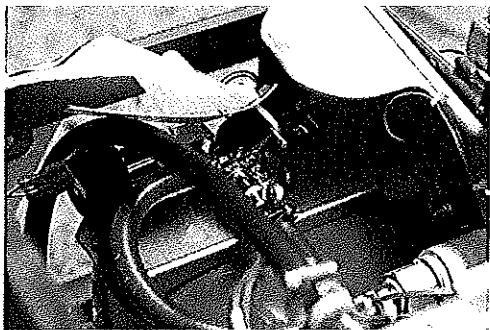

### Low Pressure

#### HOW TO TEST FUNCTION

- Unplug one of the wire terminal connections attached to the pressure switch.
- LED turns from green to orange blinking with buzzer.
- Power for gas valve or disconnect turns off.
- Audible buzzer inside of hood beeps 4 times.
- Local Alarm Activation "Y0-C0".
- Hood remains powered.

### Loose Connection on Discharge Hose

#### HOW TO TEST FUNCTION

- Unplug the hose quick disconnect coupling to discharge manifold.
- LED turns from green to orange blinking with buzzer.
- Power for gas valve or disconnect turns off.
- Audible buzzer inside of hood beeps 3 times.
- Local Alarm Activation "Y0 to C0".
- Hood remains powered.

### High Temperature Switch

#### HOW TO TEST FUNCTION

- Unplug red wire terminal located on terminal strip #4. NOTE: Do not remove the wire, just unplug the terminal. You can also use a heat gun on the center of the hood to simulate a high temperature.
- LED turns from green to orange blinking with buzzer.
- Power for gas valve or disconnect turns off.
- Audible buzzer inside of hood beeps 5 times.
- Local Alarm Activation "Y0 to C0".
- Fan turns on.
- Fan remains on for 3 minutes after you lower temperature or put red wire back on.
- Hood remains powered.

### Low Temperature Switches

#### HOW TO TEST FUNCTION

- Use heat gun on either left or right low temp switch.
- Fan turns on.
- Fan remains on for three minutes after temperature falls below 150°F.

### High Temperature and Low Pressure Switches

#### HOW TO TEST FUNCTION

- Unplug red wire terminal located on terminal strip #4. NOTE: Do not remove wire, just unplug it's round connector. Unplug one of the wire terminal connection attached to pressure switch.
- Fan turns on.
- LED turns from green to orange.
- Power for gas valve or disconnect turns off.
- Audible buzzer inside of hood on continuously.
- Local Alarm Activation "Y0 to C0".
- Remote Alarm Activation "Y1 to C1".
- Hood remains powered.

### Alarm Discharge Switch

#### HOW TO TEST FUNCTION

- Depress actuator lever located at the micro-switch next to tank.
- Check continuity of both normally open and closed contacts.

### Service Switch in ON (1) Position

#### HOW TO TEST FUNCTION

- LED turns from green to blinking orange/green.
- Power for gas valve or disconnect turns off.
- No alarm closure at Y1-C1 or Y0-C0.
- Pressing the reset button will not reset the hood until the service switch is put back in the off (normal) position.

## After an Actuation

The fire suppression system must be recharged and restored to service immediately after any discharge for continued fire suppression protection.

### WARNING

- Safety glasses and gloves must be worn for all the following operations. Flush thoroughly with clean water if agent comes in contact with skin or eyes.
- Allow time for cooling before attempting any cleaning. Using water to clean any appliance that contains hot grease or cooking oils, may result in violent steaming or splattering.

## Clean-Up Procedures

Due to the alkaline nature of the fire suppressing agent, kitchen surfaces must be cleaned immediately after system discharge. The wet chemical agent discharged produces a foamy by-product that can be wiped up with a cloth or sponge.

Clean-up procedures are as follows:

1. Before clean-up ensure that all fuel or electrical sources to the equipment to be cleaned have been shut off. Unplug exhaust hood and all appliance electrical controls to avoid any chance of electrical shock resulting from the cleaning process or from an electrically conductive liquid agent.
2. Discard food and cooking oil that has contacted the extinguishing agent since it is no longer suitable for consumption.
3. Wipe up as much of the agent as possible with paper towel or disposable rags.
4. Use hot, soapy water to clean away all residue and any surfaces that the agent has come in contact with.
5. Completely dry all areas before continuing the service procedure.

## Inspect the Unit for Damage

Be sure no components of the hood were damaged from fire/heat.

## Determine Cause of Discharge

Determining the reason for the system discharge before recharging the fire suppression system and resetting the unit is critical to ensure either the system performed as designed, or was caused by a component malfunction. Great care has been taken to simplify field installations, so system malfunctions should be extremely rare.

- A fire may have caused the fusible links to melt, causing the system to discharge. In case of fire, inspect the electrical system and all wiring for heat damage.
- The remote pull station (optional) may have been pulled.
- If fusible links have not been changed within the past 12 months, they may have stretched and released the actuation cable.

## How to Reset the Suppression System

**Resetting and testing release mechanisms, remote pull, and fusible links.**

Reset detection system by completing the following steps:

1. Remove extinguisher tank
2. Make sure tension arm cable is in the released slack position.
3. Remove the 3 fusible links from the cable assembly and replace links with 2 new properly rated links and one test link at terminal end.
4. Return tension arm and cable mechanism to a cocked position.
5. Using wire snips, cut the test link at the terminal end to simulate an actuation.
6. If system actuates successfully, go to Step 8.
7. If the release mechanism does not actuate, check the following components and remedy any disorder as follows:
  - a. Check the detector links for correct positioning through pulleys in system and for possible twists or knots in the cable
  - b. Ensure that actuator arm is in place and is cocked.
  - c. Retest the system after installing a new test link on the terminal end.
  - d. Verify that safety pin is removed from suppression tank. If problems persist call the factory at 1-800-371-6858.
8. Upon successful actuation of the system, complete the following steps:
  - a. Release cable from actuation lever and install a properly rated fusible link in the terminal location.
  - b. Replace extinguisher tank and reattach cable to actuation lever to place it into its "ready" position.

## Recharge Tank

1. Placing the hood into the service position allows for removal of tank and examination of components.
2. Disconnect the tank pressure switch and the hose discharge assembly connection and remove the tank from the hood. It is recommended to replace the pin back into the tank in case of left over suppression media.
3. Remove the tank valve assembly and inspect the valve and O-rings for damage. Thoroughly flush the valve and O-ring with water.
4. Once flushing is complete, refill the tank with the measured amount in the recharge and refill kit, screw on valve assembly, and recharge with nitrogen to a pressure of 100-105 psi (green zone on pressure gauge).
5. Reinstall tank and ensure all systems have been thoroughly checked and retested with new links. The system can now be put into service.

The pressure gauge is directly plumbed to the wet chemical tank valve assembly and indicates the pressure status of the nitrogen in the tank. The tank includes a pressure switch that closes if pressure is in the "green" or normal operation range.

#### **Resetting Gas Shut-Off Valve**

Before the gas supply is turned back on, extinguish any open flames and turn off all burners and any electrical or mechanical devices that are capable of igniting gas to reduce the risk of explosion due to leaking gas. Check to ensure the power switch is on.

Reset gas shut-off valve by completing the following steps:

1. On the top of the hood press the white manual reset button. The gas valve will energize into its normal operating (open) position.
2. Examine burners for gaseous odor. If gas odor exists, turn off power switch which will cause the gas valve to close and shut off gas supply. Clear gas fumes by opening windows and doors and then correct gas leak before proceeding.
3. Reset gas valve again and if there is no gaseous odor, pilot lights may be ignited at this time. Gas stoves with a pilot light that is always on require added caution. The pilot light must be relit manually.

#### **Resetting Electrical Relay Shut-Off**

1. Check to ensure the power source is on.
2. Press the white manual reset switch on the top of the hood.
3. Status LED will turn from red to green.

If the system does not reset, one of the following possibilities may be the problem:

- Tank hose not connected properly
- Tank pressure sensor wire disconnected
- Tank not to adequate pressure
- Electric power is shut off



## Maintaining the System

### Cleaning the Hood

To remove built up grease and cooking debris, clean the unit thoroughly with mild detergent and water. Be careful when using abrasive cleaning pads as they may scratch or mar the stainless steel surfaces. The grease entrapment filter, front discharge grille and grease tray are dishwasher safe. The carbon filter cannot be washed and should be replaced periodically as needed.

### Inspection Procedures

#### Inspect the Nozzle Caps

The nozzle caps should be inspected and cleaned. All five (5) nozzles should have protective caps installed. If necessary, remove the caps and check for build up of debris or any signs of clogging of the nozzle orifice. If clogging is suspected, remove the nozzle with a 7/16-inch wrench, and flush with hot water until it flows freely through the nozzle.

Replace the nozzle and protective cap.

Replacement caps and nozzle O-rings are available from Greenheck or through your representatives.

#### WARNING

The protective caps stay on the nozzles at all times. In the event of a discharge, the caps will blow off.

#### Inspect Fusible Link System\*

Periodic inspection of the fusible link system ensures the unit is ready to work in the case of a fire.

1. Place safety pin in tank valve.
2. Remove tank from hood.
3. Remove tension from cable system by loosening the turnbuckle.
4. If the fusible links need to be replaced, call 1-800-355-5354 or contact your representative.
5. Inspect pulleys and cable. Pulleys should rotate freely and cable should be flexible. Everything should be free of grease build-up.
6. Tighten the turnbuckle, reapplying tension to the stainless steel rope, making sure the cable is running through the pulleys properly and there are no kinks or knots.
7. Reposition the tank.
8. Remove safety pin from tank valve.

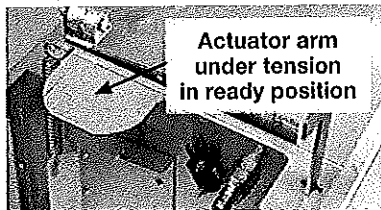

\*Each fusible link is date-stamped and must be replaced if expired or after 12 months of use.

#### WARNING

If grease build-up on the cable system is not kept to a minimum, the cable could become stiff and will not discharge the suppressant in the event of a fire.

### 10 Year Maintenance

Hydrostatic testing and new liquid agent, or tank replacement is recommended at ten-year intervals. The manufactured date is stamped on the top of the tank. This should be performed by an authorized technician or at the manufacturer's facilities. Material safety data sheets are available from Greenheck.

#### WARNING

Rubber gloves and safety glasses should be worn during service or inspection of the tank. If contact with the chemical agent skin or eyes occurs, flush immediately with water for 15 minutes. If irritation persists, contact a physician. If taken internally, do not induce vomiting. Dilute with water or milk and contact a physician.

### Lighting

Illumination is provided by a 60 watt medium-base shatterproof incandescent light bulb. To replace, make sure the light switch is in the "OFF" position and then gently unscrew the bulb. (Bulb: 60A15/TF)

### Removing the Extinguisher Tank

1. Lower the hood to its service position
2. Insert the safety pin in the valve head so that accidental release of the suppressant does not occur.
3. Unplug the pressure switch wire and move it out of the way for now.
4. Disconnect the discharge hose from its fitting located inside the unit closest to the user.
5. Unscrew the two wingnuts holding the bracket for the tank.
6. Lift the tank out of the hood.
7. To replace the tank, simply reverse these steps.

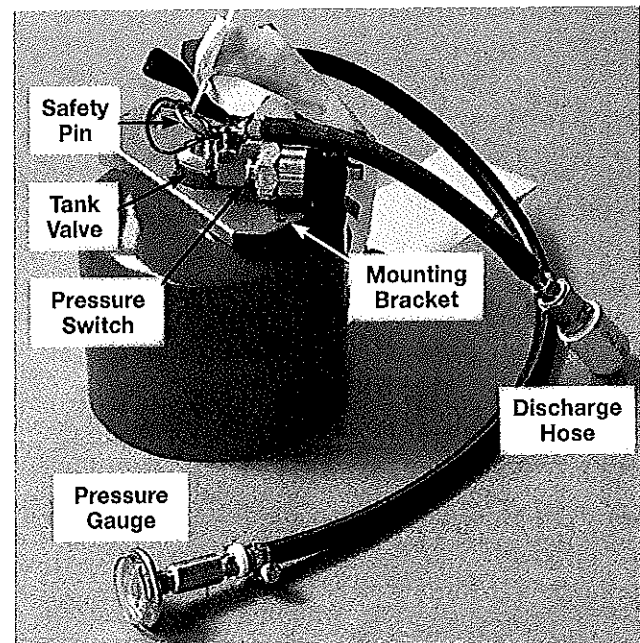

## Recommended Service and Recertification Schedule

### WARNING

Safety glasses must be worn whenever service operations are performed.

	Monthly	Annually	Every 10 years
Cleaning	Yes	Yes	
Suppression Nozzles	Inspect	Inspect	
Fusible Links	Inspect	Replace	
Extinguisher Tank	Inspect	Recertify	Replace

## Replacement Parts

Part Number	Description
479683	Fire Ready Annual Service Kit (3) Links and Service Tag
479684	Fire Ready Recharge Kit Tank Assembly fully charged with adapter
479685	Fire Ready Test Kit, Tank Assembly Nitro only with adapter and test link
479686	Fire Ready Tank Kit, Tank Assembly Empty with adapter
479687	Fire Ready Test Kit Set of 2 Test Links, 4 Nozzle Caps and 1 Safety Key
479688	Fire Ready Electrical Disconnect Box 208-240VAC/50A (as replacement)
479689	Fire Ready 3/4-inch Gas Valve 115VAC (as replacement)
479690	Fire Ready 60W Shatterproof Bulb, pack of 2
479691	Fire Ready Fusible Links, 212°F, 3 links
479692	Fire Ready Fusible Links, 280°F, 3 links
479693	Fire Ready Nozzle Caps, set of 10
479694	Fire Ready Wire Rope Assembly Set Hood Width of 30 inches
479695	Fire Ready Wire Rope Assembly Set Hood Width of 36 inches
479696	Fire Ready Replacement Charcoal Filters "F" Calibrations, pack of 10
479697	Fire Ready Grease Entrapment Filter
479698	Fire Ready Grease Filter Cup
479699	Fire Ready Replacement Fuse Kit for Control Systems

# Maintenance Log

Date \_\_\_\_\_ Time \_\_\_\_\_ AM/PM

Notes: \_\_\_\_\_

\_\_\_\_\_  
\_\_\_\_\_  
\_\_\_\_\_

Date \_\_\_\_\_ Time \_\_\_\_\_ AM/PM

Notes: \_\_\_\_\_

\_\_\_\_\_  
\_\_\_\_\_  
\_\_\_\_\_

Date \_\_\_\_\_ Time \_\_\_\_\_ AM/PM

Notes: \_\_\_\_\_

\_\_\_\_\_  
\_\_\_\_\_  
\_\_\_\_\_

Date \_\_\_\_\_ Time \_\_\_\_\_ AM/PM

Notes: \_\_\_\_\_

\_\_\_\_\_  
\_\_\_\_\_  
\_\_\_\_\_

Date \_\_\_\_\_ Time \_\_\_\_\_ AM/PM

Notes: \_\_\_\_\_

\_\_\_\_\_  
\_\_\_\_\_  
\_\_\_\_\_

Date \_\_\_\_\_ Time \_\_\_\_\_ AM/PM

Notes: \_\_\_\_\_

\_\_\_\_\_  
\_\_\_\_\_  
\_\_\_\_\_

Date \_\_\_\_\_ Time \_\_\_\_\_ AM/PM

Notes: \_\_\_\_\_

\_\_\_\_\_  
\_\_\_\_\_  
\_\_\_\_\_

Date \_\_\_\_\_ Time \_\_\_\_\_ AM/PM

Notes: \_\_\_\_\_

\_\_\_\_\_  
\_\_\_\_\_  
\_\_\_\_\_

Date \_\_\_\_\_ Time \_\_\_\_\_ AM/PM

Notes: \_\_\_\_\_

\_\_\_\_\_  
\_\_\_\_\_  
\_\_\_\_\_

Date \_\_\_\_\_ Time \_\_\_\_\_ AM/PM

Notes: \_\_\_\_\_

\_\_\_\_\_  
\_\_\_\_\_  
\_\_\_\_\_

Date \_\_\_\_\_ Time \_\_\_\_\_ AM/PM

Notes: \_\_\_\_\_

\_\_\_\_\_  
\_\_\_\_\_  
\_\_\_\_\_

Date \_\_\_\_\_ Time \_\_\_\_\_ AM/PM

Notes: \_\_\_\_\_

\_\_\_\_\_  
\_\_\_\_\_  
\_\_\_\_\_

## Our Commitment

*As a result of our commitment to continuous improvement, Greenheck reserves the right to change specifications without notice.*

Specific Greenheck product warranties are located on [greenheck.com](http://greenheck.com) within the product area tabs and in the Library under Warranties.

Greenheck's Fire Ready Residential Range Hood, Model GRRS catalog provides additional information describing the equipment, available accessories, and specification data.

AMCA Publication 410-96, Safety Practices for Users and Installers of Industrial and Commercial Fans, provides additional safety information. This publication can be obtained from AMCA International, Inc. at [www.amca.org](http://www.amca.org).



Phone: 715.359.6171 • Fax: 715.355.2399 • Parts: 800.355.5354 • E-mail: [gfcinfo@greenheck.com](mailto:gfcinfo@greenheck.com) • Website: [www.greenheck.com](http://www.greenheck.com)