

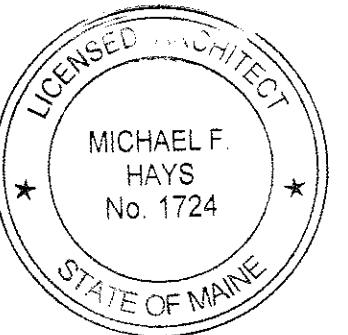

GRANT HAYS
ASSOCIATES

ARCHITECTURE & INTERIOR DESIGN
P.O. BOX 6179 FALMOUTH MAINE 04103
207.871.5900 www.granthays.com

J/AL



Michael F. Hays
REVISION/

PROJECT NAME

3RD FLOOR TOILET
UPGRADES & MISC.
19 CROSS ST./ 261 COMMERCIAL ST.
PORTLAND, MAINE 04101

J/HEET

ACCESSIBILITY
DETAILS
& NOTES

DATE
9 JUNE 2014

J/SCALE
NO SCALE

DRAWN
MFH

JOB NO.
140619

J/HEET

A 4

COPYRIGHT
REPRODUCTION OR REVUE OF THIS
DOCUMENT WITHOUT WRITTEN
PERMISSION FROM GRANT HAYS/
ASSOCIATES IS PROHIBITED.

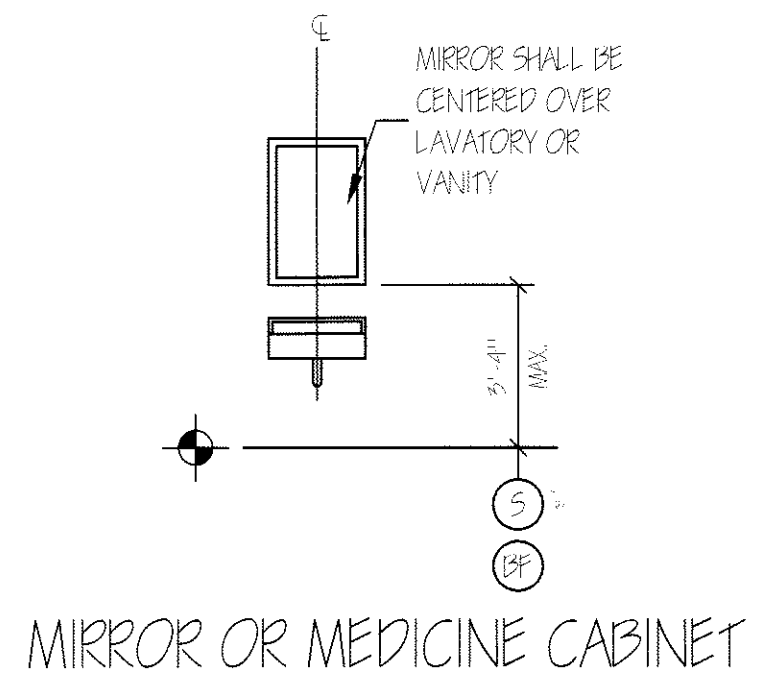

MIRROR OR MEDICINE CABINET
NTS

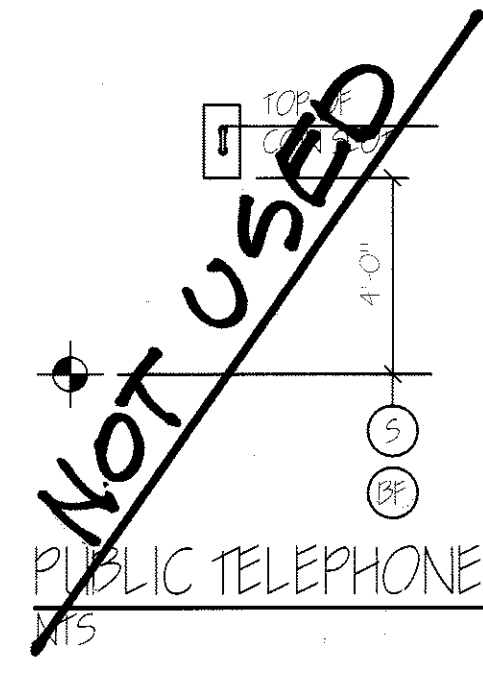

~~NOT USED~~
PUBLIC TELEPHONE
NTS

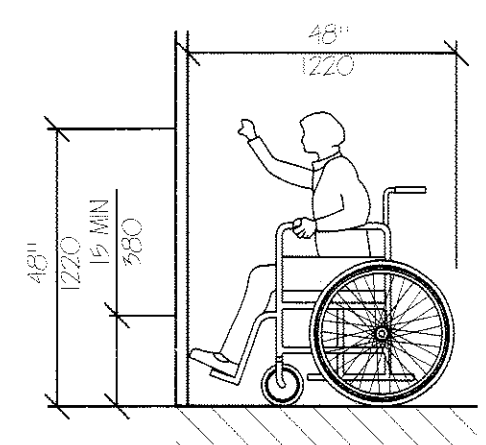

HIGH FORWARD REACH LIMIT
NTS

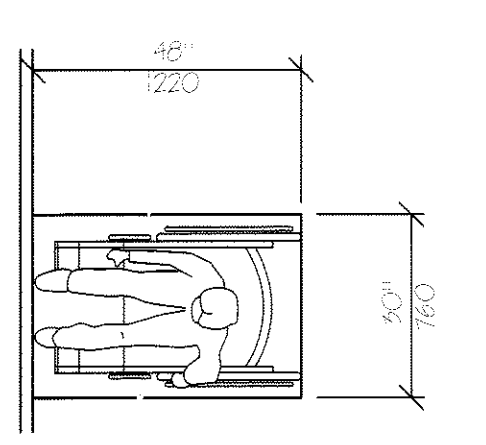

STORAGE SHELVES AND CLOSETS
NTS

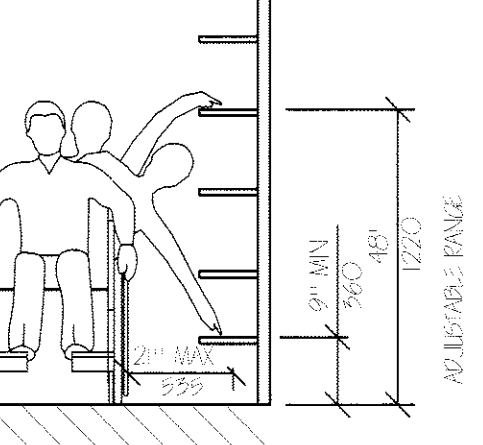

SHELVES
NTS

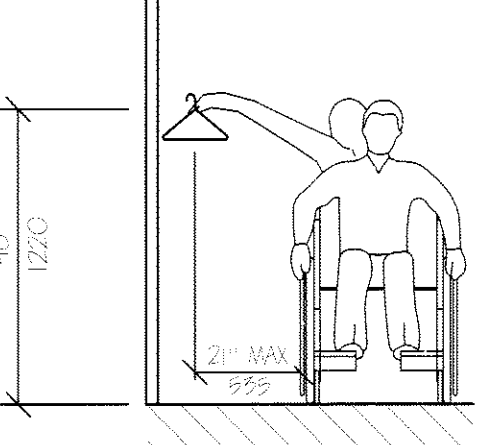

CLOSETS
NTS

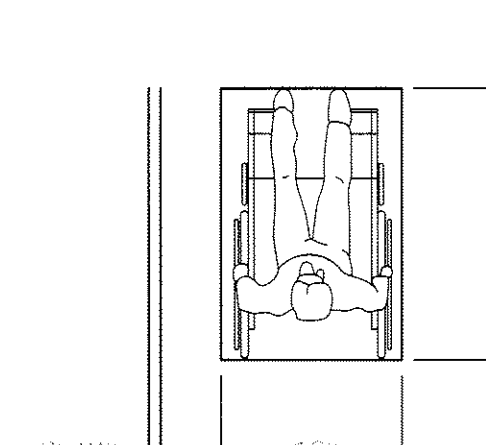

CLEAR FLOOR SPACE
PARALLEL APPROACH
NTS

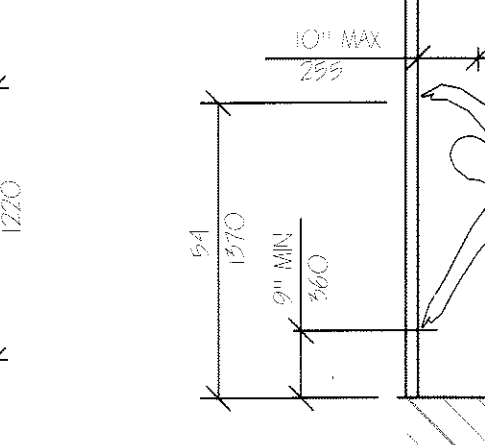

HIGH AND LOW
SIDE REACH LIMITS
NTS

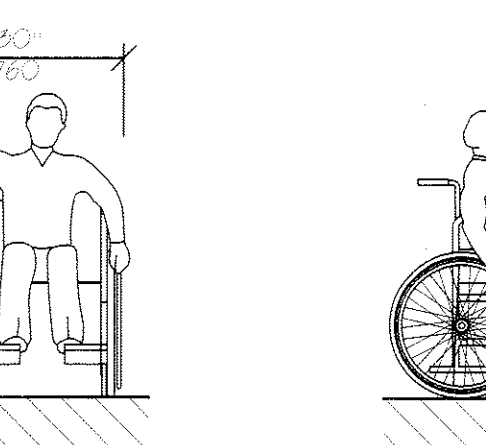

LAVATORY CLEARANCES
NTS



~~NOT USED~~
FIRE EXTINGUISHER
CABINET (FEC)
NTS

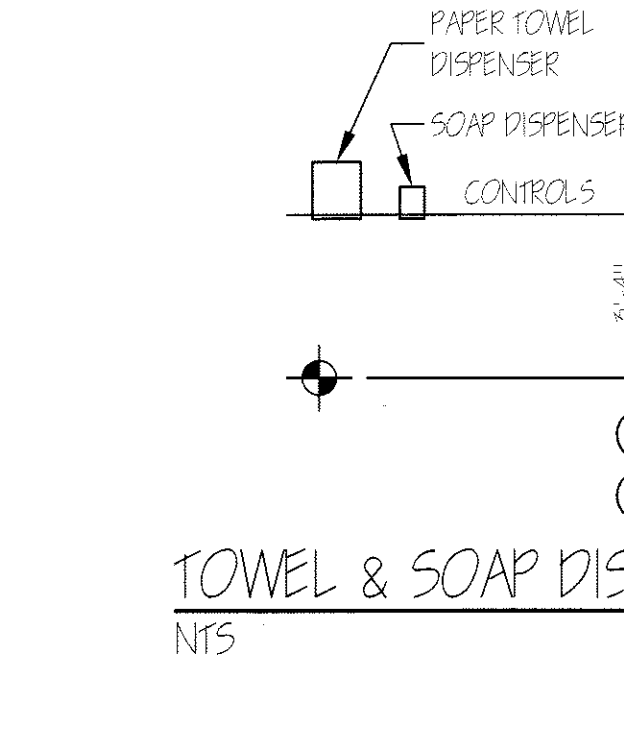

TOWEL & SOAP DISPENSERS
NTS

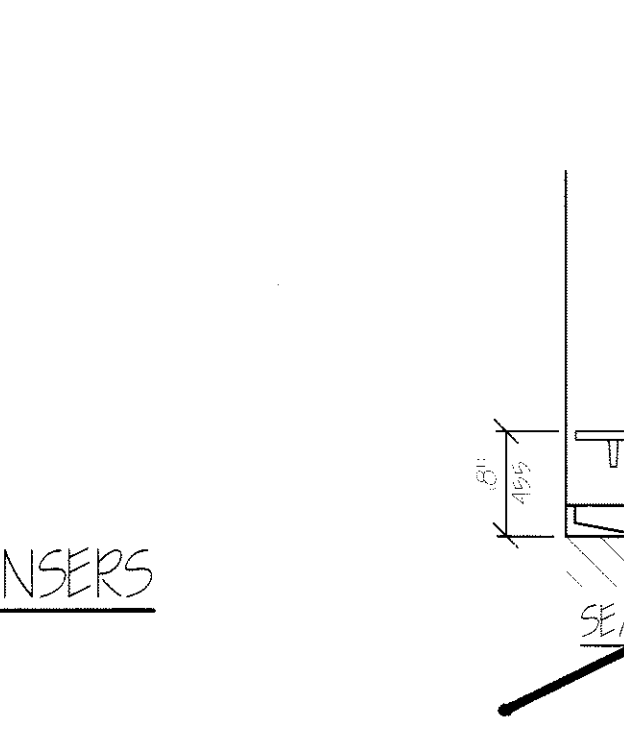

~~NOT USED~~
SHOWER SEAT ELEVATIONS
NTS

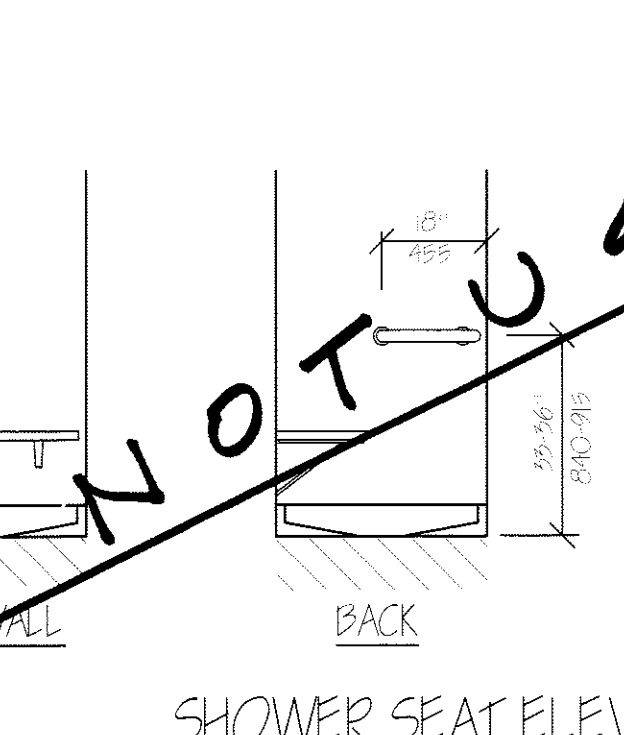

~~NOT USED~~
SHOWER STALL PLAN
NTS

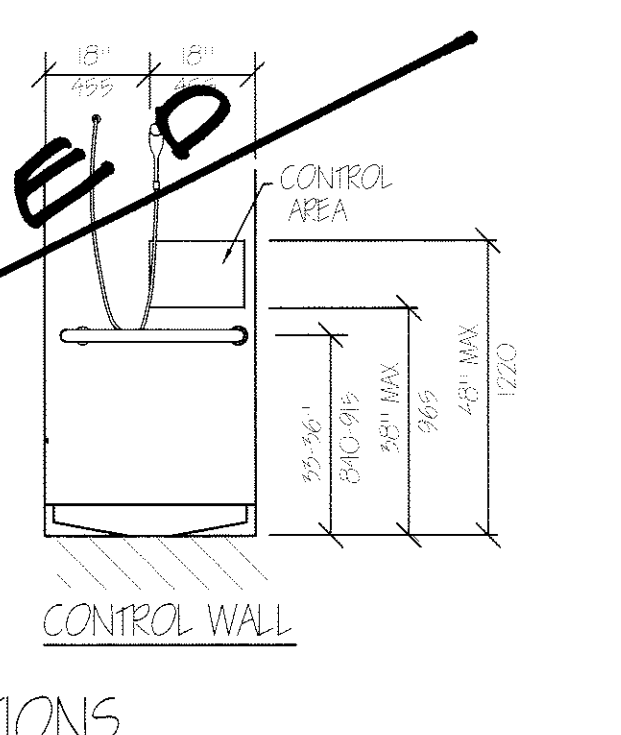

~~NOT USED~~
SHOWER SEAT DESIGN
NTS

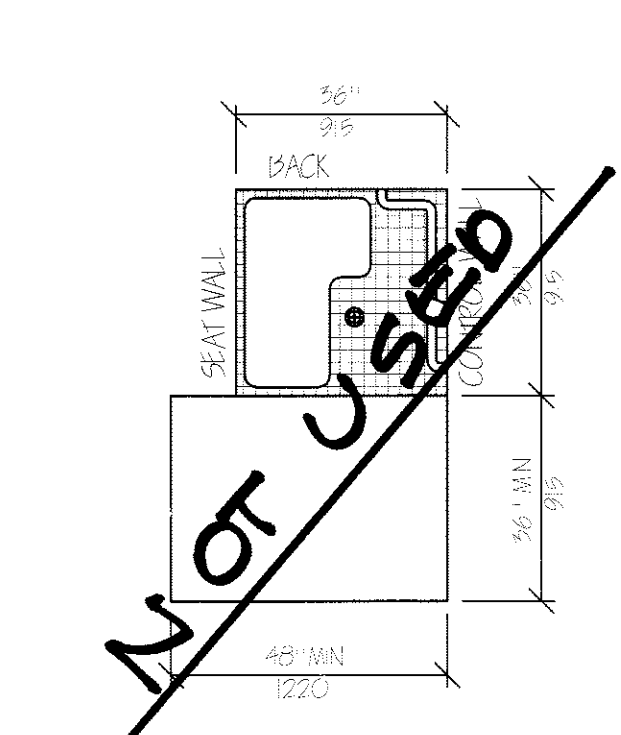

~~NOT USED~~
CLEAR FLOOR SPACE
AT LAVATORIES
NTS

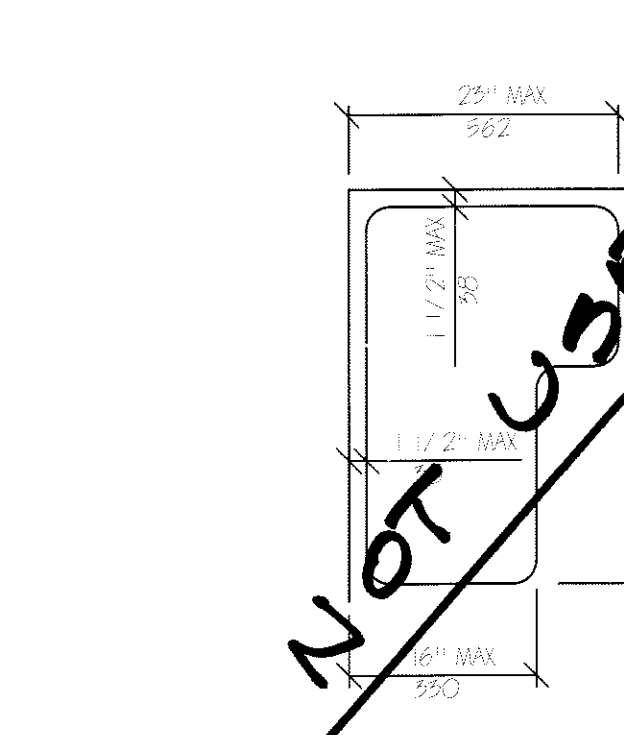

~~NOT USED~~
CLEAR FLOOR SPACE
AT LAVATORIES
NTS

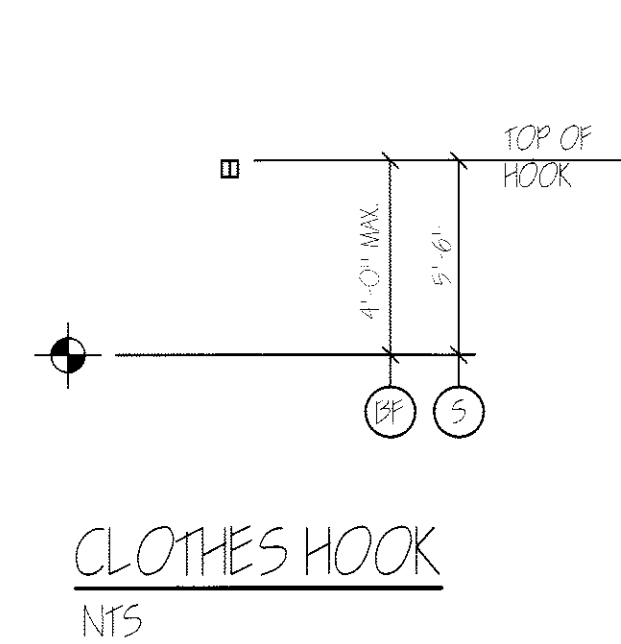

CLOTHES HOOK
NTS

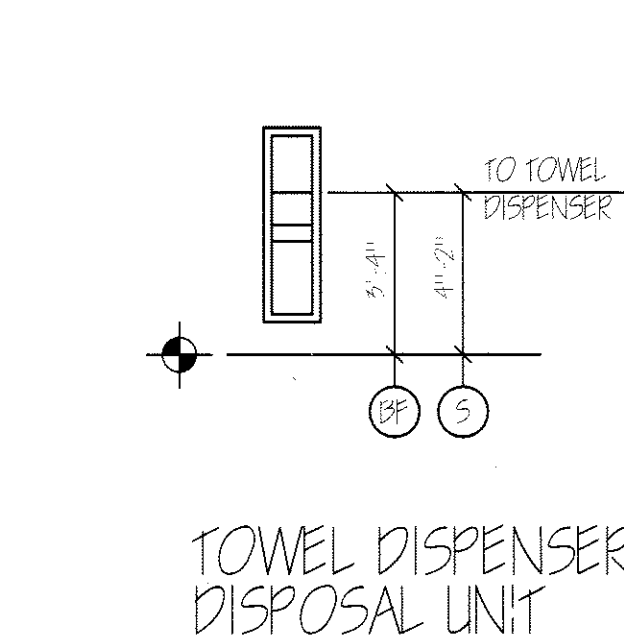

TOWEL DISPENSER
DISPOSAL UNIT
NTS

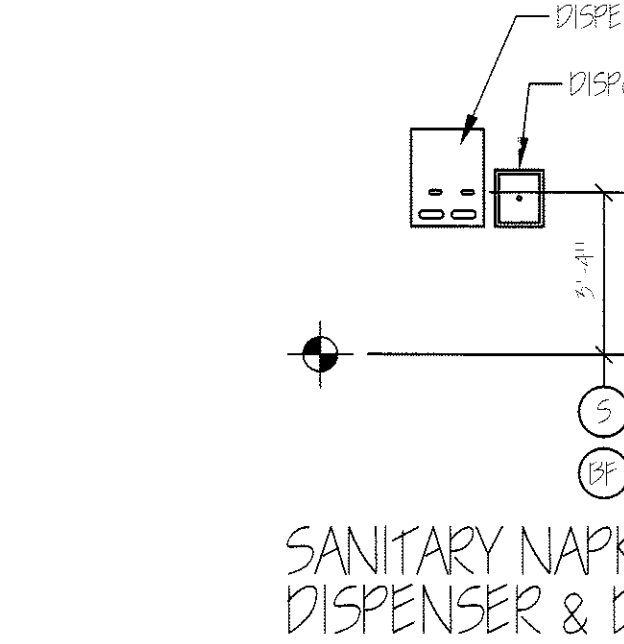

SANITARY NAPKIN
DISPENSER & DISPOSAL
NTS

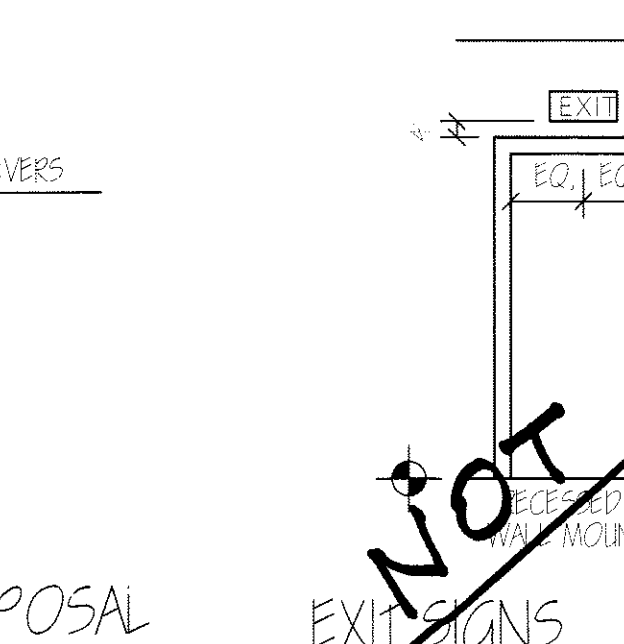

~~NOT USED~~
EXIT SIGNS
TYPICAL UNLESS OTHERWISE NOTED
NTS

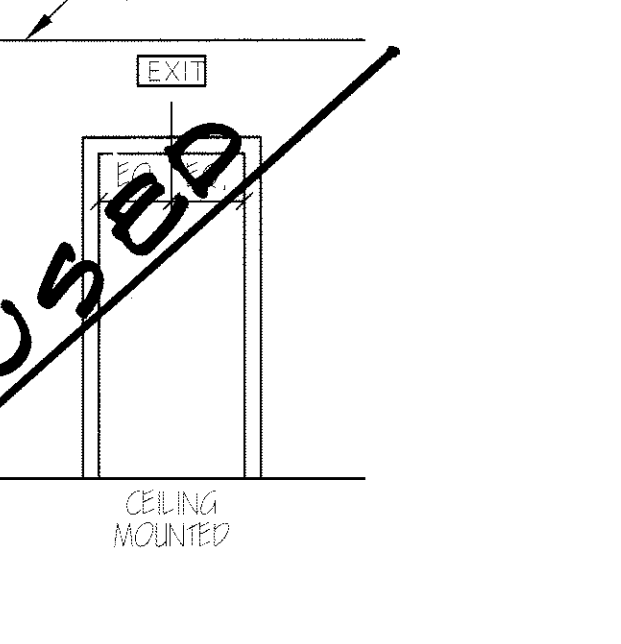

~~NOT USED~~
EQUIPMENT PERMITTED IN SHADED AREA
DRINKING FOUNTAIN SPOUT HEIGHT
AND KNEE CLEARANCE
NTS

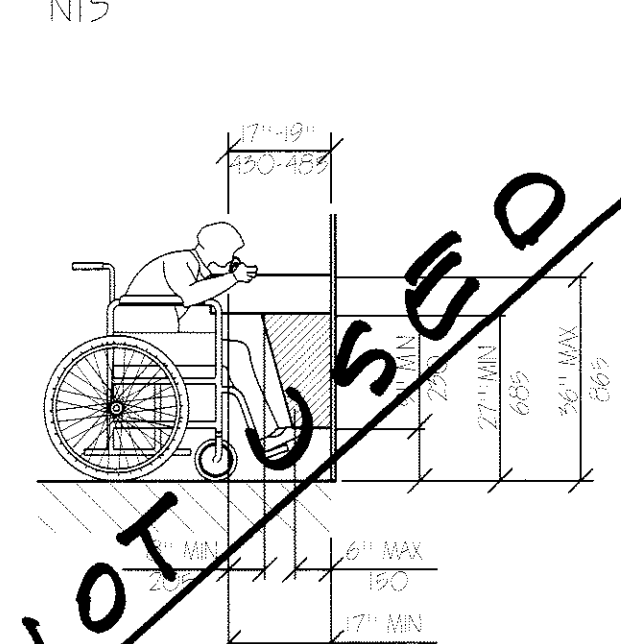

~~NOT USED~~
DRINKING FOUNTAIN
NTS

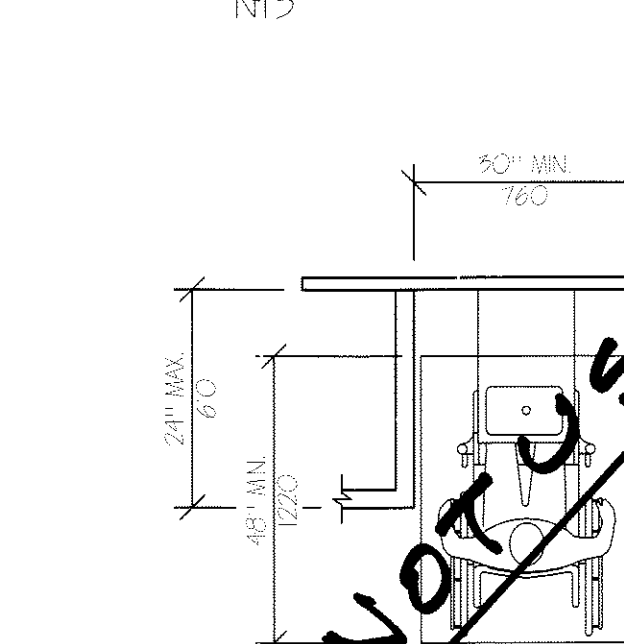

~~NOT USED~~
HEIGHT AND DEPTH OF URINALS
NTS

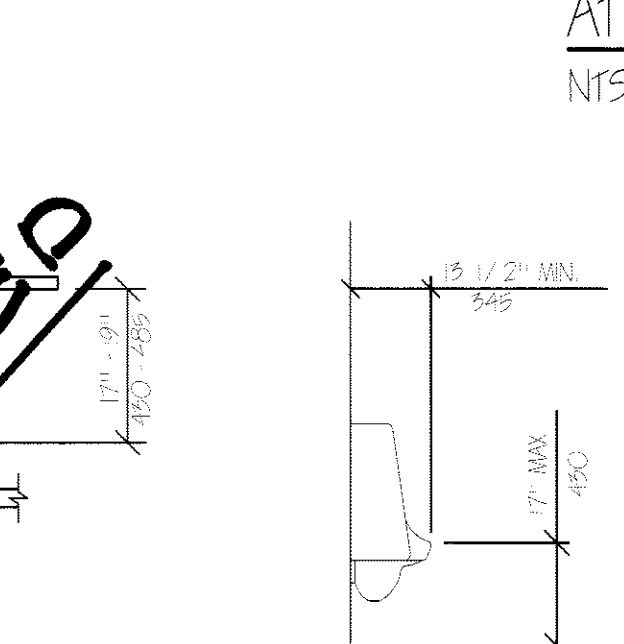

~~NOT USED~~
HEIGHT AND DEPTH OF URINALS
NTS

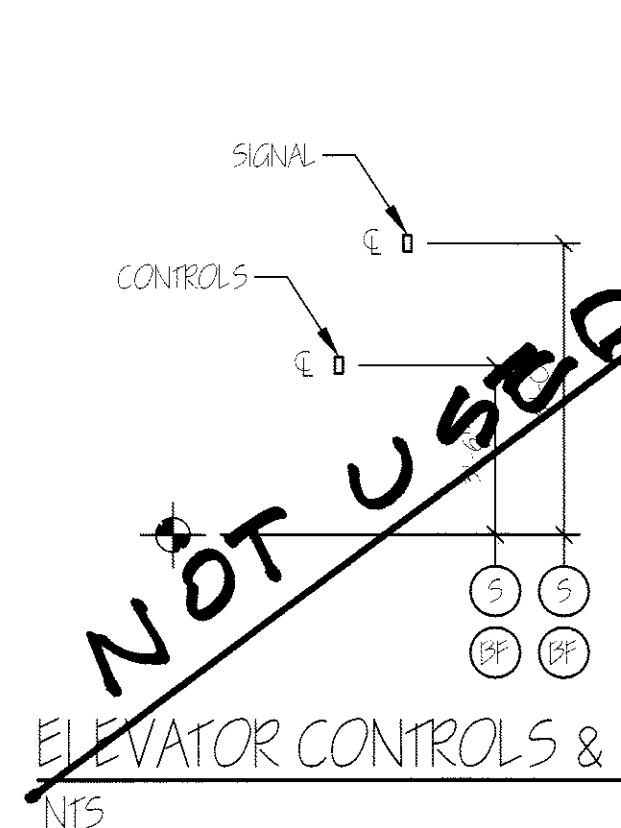

~~NOT USED~~
ELEVATOR CONTROLS & SIGNALS
NTS

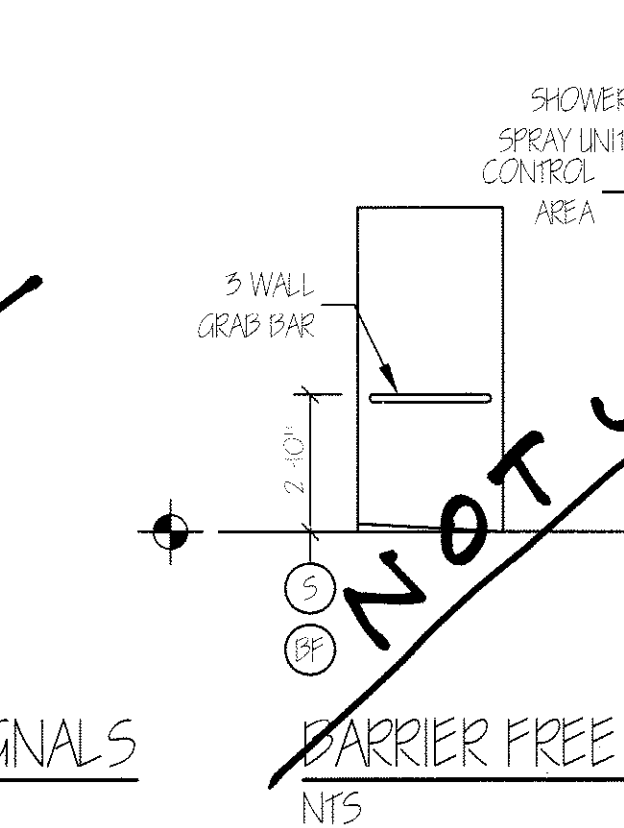

~~NOT USED~~
BARRIER FREE SHOWER
NTS

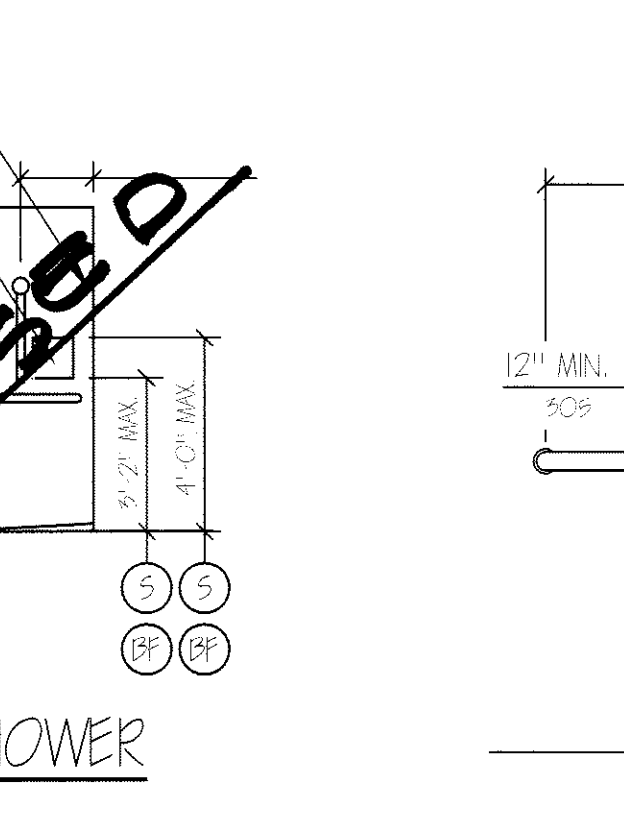

~~NOT USED~~
GRAB BARS AT WATER CLOSETS
NTS

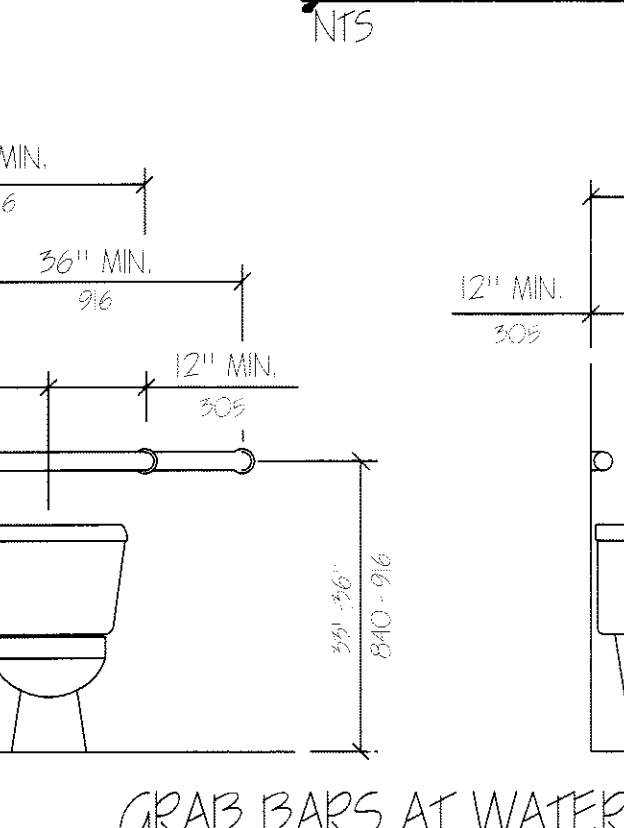

~~NOT USED~~
GRAB BARS AT WATER CLOSETS
NTS

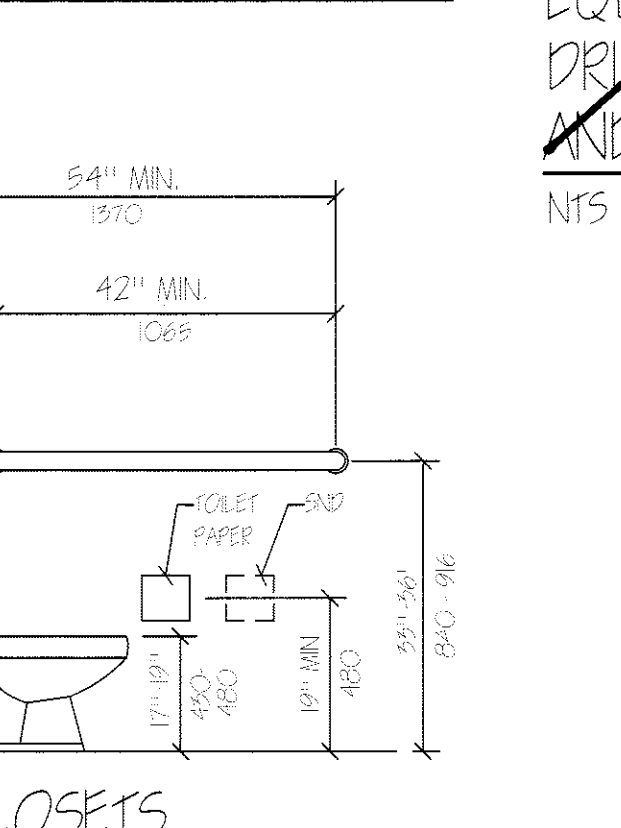

~~NOT USED~~
GRAB BARS AT WATER CLOSETS
NTS

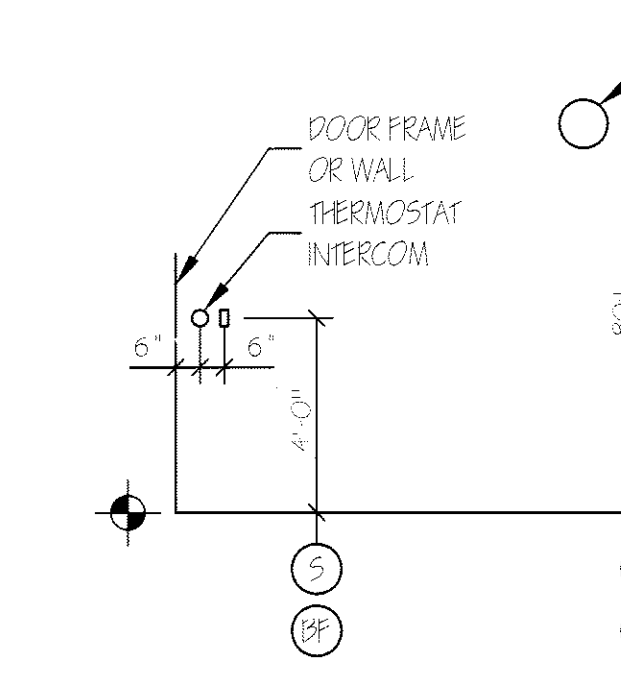

ELECTRICAL & FIRE PROTECTION DEVICES
TYPICAL UNLESS NOTED OTHERWISE
NTS

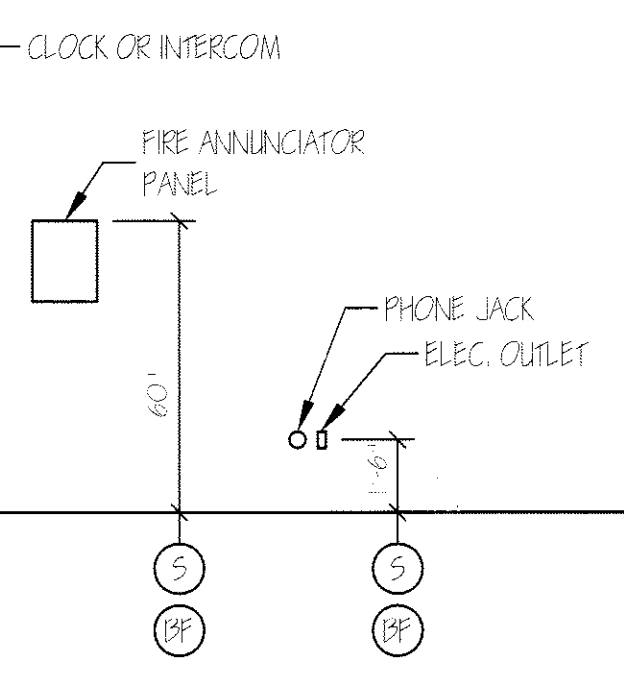

ELECTRICAL & FIRE PROTECTION DEVICES
TYPICAL UNLESS NOTED OTHERWISE
NTS

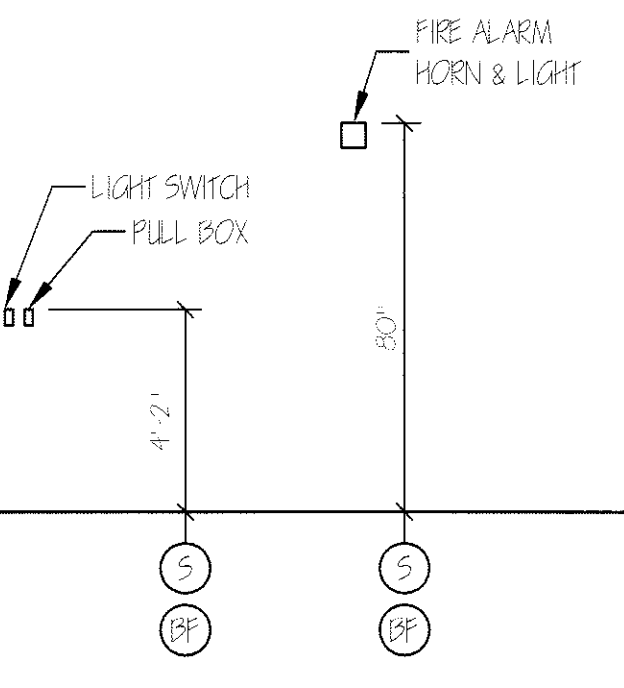

ELECTRICAL & FIRE PROTECTION DEVICES
TYPICAL UNLESS NOTED OTHERWISE
NTS



ELECTRICAL & FIRE PROTECTION DEVICES
TYPICAL UNLESS NOTED OTHERWISE
NTS

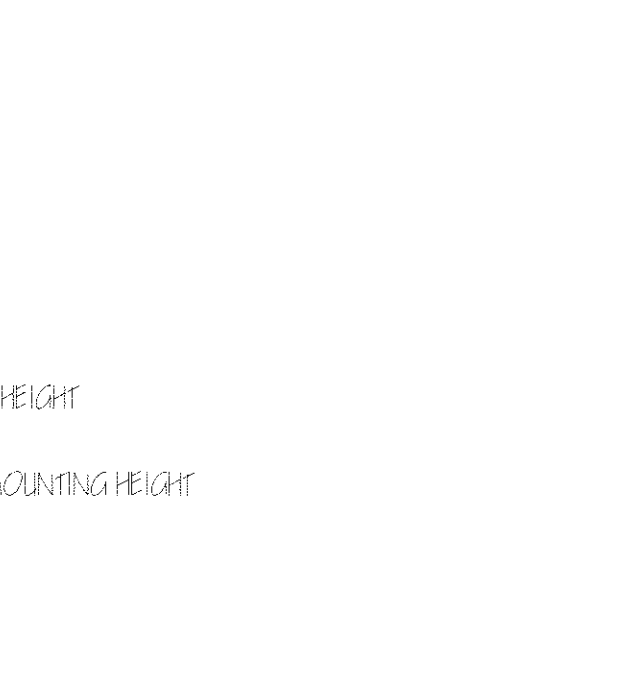

ELECTRICAL & FIRE PROTECTION DEVICES
TYPICAL UNLESS NOTED OTHERWISE
NTS

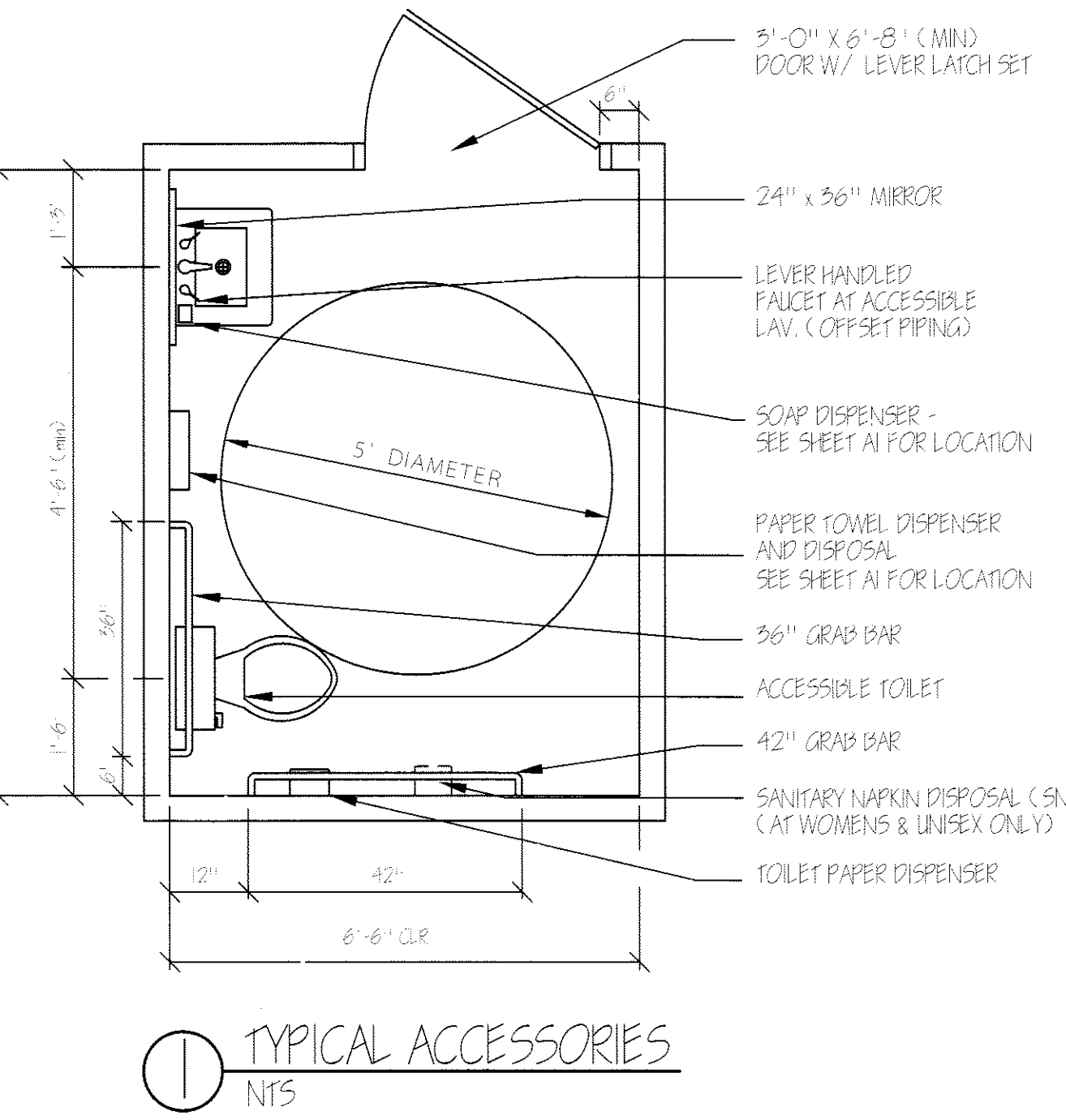

TYPICAL ACCESSORIES
NTS

ACCESSIBILITY ACCESSORY
MOUNTING HEIGHTS

GRAB BARS	33" - 36"
TOILET PAPER HOLDER	19" MIN
TOWEL BAR / PAPER TOWEL DISPENSER	48" MAX
BUILT IN PAPER TOWEL DISPENSER	48" MAX
SOAP DISH / DISPENSER AT WALL	48" MAX
SANITARY NAPKIN DISPENSER	48" MAX
SANITARY NAPKIN DISPOSAL	19" MAX
MIRROR (BOTTOM)	40" MAX
SHELVES / STORAGE	48" MAX
ELECTRICAL SWITCHES / OUTLETS	48" MAX
COAT HOOKS / ROOFS	48" MAX
SIGNAGE (TO BRAILLE COMPONENT)	60" MAX

ACCESSIBILITY GENERAL NOTES

1. DOORWAYS SHALL HAVE A MINIMUM CLEAR WIDTH OF 32" WITH THE DOOR OPEN 90 DEGREES. MEASURED BETWEEN THE FACE OF THE DOOR AND THE OPPOSITE STOP.
2. ALL DOORS SHALL HAVE LEVER HANDLE HARDWARE, EXCEPT AT SECURED STORAGE ROOMS, MECHANICAL ROOMS, AND ELEVATOR MACHINE ROOMS.
3. ALL CLOSERS SHALL BE 5LB PULL MAXIMUM AT DOORS EQUIPPED WITH LEVER HANDLE HARDWARE.
4. ALL DOORS WITH CLOSERS SHALL HAVE 18" CLEAR DISTANCE FROM THE LATCHSIDE OF THE OPENING TO ANY ADJACENT WALL OR OBSTRUCTION ON THE PULL SIDE OF THE OPENING.
5. ALL DOORS WITH CLOSERS SHALL HAVE 12" CLEAR DISTANCE FROM THE LATCHSIDE OF THE OPENING TO ANY ADJACENT WALL OR OBSTRUCTION ON THE PUSH SIDE OF THE OPENING.
6. ALL SIGNAGE SHALL BE MOUNTED 60" AFF TO BRAILLE COMPONENT AT LATCH SIDE WALL OF DOORS AND OPENINGS.

LEGEND

- (S) STANDARD MOUNTING HEIGHT
- (PK) BARRIER FREE ADULT MOUNTING HEIGHT
- (+/-) FINISH FLOOR LINE

NOTE

MOUNT ALL FIXTURES AT STANDARD MOUNTING HEIGHT UNLESS INDICATED ON PLAN BY A (+/-) SYMBOL. A (+/-) SYMBOL AT ANY ROOM SHALL INCLUDE ONE OF ANY FIXTURE AND ACCESSORY WITHIN THE ROOM.