

DISPLAY THIS CARD ON PRINCIPAL FRONTAGE OF WORK CITY OF PORTLAND

Please Read Application And Notes, If Any, Attached

BUILDING DEPARTMENT

PERMIT

Permit Number: 080031

This is to certify that HARBOR PLAZA ASSOCIATION S II / AL Construction
has permission to Interior Renovation to existing Hotel Lobby and Dining Area. Phase 1
AT 259 COMMERCIAL ST 038 F009001

provided that the person or persons, firm or corporation accepting this permit shall comply with all of the provisions of the Statutes of Maine and of the ordinances of the City of Portland regulating the construction, maintenance and use of buildings and structures, and of the application on file in this department.

Notification of inspection must be given and when permission is procured before this building or part thereof is altered or closed-in. **24 HOUR NOTICE IS REQUIRED.**

Apply to Public Works for street line and grade if nature of work requires such information.

A certificate of occupancy must be procured by owner before this building or part thereof is occupied.

OTHER REQUIRED APPROVALS

Fire Dept. Greg Cass
Health Dept. _____
Appeal Board _____
Other _____
Department Name _____

Jeanne Bonke 2/6/08
Director - Building & Inspection Services

PENALTY FOR REMOVING THIS CARD

Scanned

PERMIT ISSUED
FEB 7 2008
CITY OF PORTLAND



CITY OF PORTLAND, MAINE

Department of Building Inspections

January 8, 2011

Received from Botswana Properties, Inc.

Location of Work 151-10 Commercial Street (4th Fl) - White

Cost of Construction \$ 177,000

Permit Fee \$ 1901.00

Building (IL) Plumbing (I5) Electrical (I2) Site Plan (U2)

Other _____

CBL: 35-1-1

Check #: 1215

Total Collected \$ 1901.00

THIS IS NOT A PERMIT

No work is to be started until PERMIT CARD is actually posted upon the premises. Acceptance of fee is no guarantee that permit will be granted. PRESERVE THIS RECEIPT. In case permit cannot be granted the amount of the fee will be refunded upon return of the receipt less \$10.00 or 10% whichever is greater.

WHITE - Applicant's Copy
YELLOW - Office Copy
PINK - Permit Copy

City of Portland, Maine - Building or Use Permit Application

389 Congress Street, 04101 Tel: (207) 874-8703, Fax: (207) 874-8716

Permit No: 08-0031	Issue Date:	CBL: 038 F009001
-----------------------	-------------	---------------------

Location of Construction: 259 COMMERCIAL ST / Fore St	Owner Name: HARBOR PLAZA ASSOCIATES I	Owner Address: PO BOX 3572	Phone: 272-2992
Business Name:	Contractor Name: Allied/Cook Construction	Contractor Address: PO Box 1396 Portland	Phone: 2077722888
Lessee/Buyer's Name	Phone:	Permit Type: Alterations - Commercial	Zone: B-3

Past Use: Commercial Hotel -Portland Harbor Hotel	Proposed Use: Commercial Hotel - Portland Harbor Hotel. Interior Renovation to existing Hotel Lobby and Dining area. Phase 1	Permit Fee: \$4,925.00	Cost of Work: \$482,600.00	CEO District: 1
		FIRE DEPT: <input checked="" type="checkbox"/> Approved <input type="checkbox"/> Denied <i>See conditions</i>	INSPECTION: Use Group: <i>R-1/A2</i> Type: <i>1B</i> <i>IBC 2003</i>	

Proposed Project Description: Interior Renovation to existing Hotel Lobby and Dining Area. Phase 1	Signature: <i>[Signature]</i>	Signature: <i>[Signature]</i> 2/6/08
PEDESTRIAN ACTIVITIES DISTRICT (P.A.D.)		
Action: <input type="checkbox"/> Approved <input type="checkbox"/> Approved w/Conditions <input type="checkbox"/> Denied		
Signature:		Date:

Permit Taken By: lmd	Date Applied For: 01/08/2008	Zoning Approval
-------------------------	---------------------------------	------------------------

<p>1. This permit application does not preclude the Applicant(s) from meeting applicable State and Federal Rules.</p> <p>2. Building permits do not include plumbing, septic or electrical work.</p> <p>3. Building permits are void if work is not started within six (6) months of the date of issuance. False information may invalidate a building permit and stop all work..</p>	<p>Special Zone or Reviews</p> <p><input type="checkbox"/> Shoreland</p> <p><input type="checkbox"/> Wetland</p> <p><input type="checkbox"/> Flood Zone</p> <p><input type="checkbox"/> Subdivision</p> <p><input type="checkbox"/> Site Plan</p> <p>Maj <input type="checkbox"/> Minor <input type="checkbox"/> MM <input type="checkbox"/></p> <p>Date: <i>1/10/08</i></p>	<p>Zoning Appeal</p> <p><input type="checkbox"/> Variance</p> <p><input type="checkbox"/> Miscellaneous</p> <p><input type="checkbox"/> Conditional Use</p> <p><input type="checkbox"/> Interpretation</p> <p><input type="checkbox"/> Approved</p> <p><input type="checkbox"/> Denied</p> <p>Date:</p>	<p>Historic Preservation</p> <p><input checked="" type="checkbox"/> Not in District or Landmark</p> <p><input type="checkbox"/> Does Not Require Review</p> <p><input type="checkbox"/> Requires Review</p> <p><input type="checkbox"/> Approved</p> <p><input type="checkbox"/> Approved w/Conditions</p> <p><input type="checkbox"/> Denied</p> <p>Date:</p>
---	---	--	---

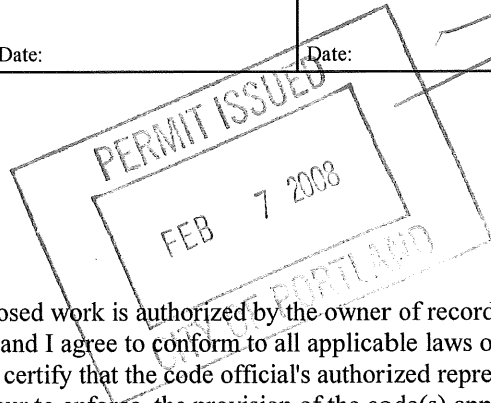

CERTIFICATION

I hereby certify that I am the owner of record of the named property, or that the proposed work is authorized by the owner of record and that I have been authorized by the owner to make this application as his authorized agent and I agree to conform to all applicable laws of this jurisdiction. In addition, if a permit for work described in the application is issued, I certify that the code official's authorized representative shall have the authority to enter all areas covered by such permit at any reasonable hour to enforce the provision of the code(s) applicable to such permit.

SIGNATURE OF APPLICANT _____ ADDRESS _____ DATE _____ PHONE _____

RESPONSIBLE PERSON IN CHARGE OF WORK, TITLE _____ DATE _____ PHONE _____

City of Portland, Maine - Building or Use Permit

389 Congress Street, 04101 Tel: (207) 874-8703, Fax: (207) 874-8716

Permit No: 08-0031	Date Applied For: 01/08/2008	CBL: 038 F009001
------------------------------	--	----------------------------

Location of Construction: 259 COMMERCIAL ST	Owner Name: HARBOR PLAZA ASSOCIATES II	Owner Address: PO BOX 3572	Phone: () 272-2992
Business Name:	Contractor Name: Allied/Cook Construction	Contractor Address: PO Box 1396 Portland	Phone: (207) 772-2888
Lessee/Buyer's Name	Phone:	Permit Type: Alterations - Commercial	

Proposed Use: Commercial Hotel - Portland Harbor Hotel. Interior Renovation to existing Hotel Lobby and Dining area. Phase 1	Proposed Project Description: Interior Renovation to existing Hotel Lobby and Dining Area. Phase 1
--	--

Dept: Zoning **Status:** Approved **Reviewer:** Marge Schmuckal **Approval Date:** 01/10/2008
Note: **Ok to Issue:**

Dept: Building **Status:** Approved with Conditions **Reviewer:** Jeanine Bourke **Approval Date:** 02/06/2008
Note: **Ok to Issue:**

- 1) Approved with condition that a floor plan design showing appliances, fixtures and plumbing shall be submitted for the the new bar and service area to review for compliance with the food code
- 2) Separate permits are required for any electrical, plumbing, or HVAC systems. Separate plans may need to be submitted for approval as a part of this process.
- 3) All penetrations through rated assemblies must be protected by an approved firestop system installed as tested in accordance with ASTM 814 or UL 1479, per IBC 2003 Section 712.

Dept: Fire **Status:** Approved with Conditions **Reviewer:** Capt Greg Cass **Approval Date:** 01/25/2008
Note: **Ok to Issue:**

- 1) The courtyard needs to be evaluated as an assembly space and means of egress shall be determined.

Comments:

2/6/2008-jmb: Spoke to Paul L. About the new bar and service area design to check compliance with the food code requirements. They have not finalized this and will submit when available. Ok to issue



General Building Permit Application

If you or the property owner owes real estate or personal property taxes or user charges on any property within the City, payment arrangements must be made before permits of any kind are accepted.

Location/Address of Construction: <u>456 - 458 FORE ST. - PORTLAND HARBOR HOTEL</u>		
Total Square Footage of Proposed Structure/Area <u>5296 SFT INTERIOR RENOVATION</u>		Square Footage of Lot <u>—</u>
Tax Assessor's Chart, Block & Lot Chart# Block# Lot# <u>38 · F · 9</u>	Applicant * <u>must be owner, Lessee or Buyer</u> * Name <u>HARBOR PLAZA ASSOC. II</u> Address <u>456 - 458 FORE ST.</u> City, State & Zip <u>PORTLAND, 04101</u>	Telephone: <u>272-2992</u>
Lessee/DBA (If Applicable) <u>PORTLAND HARBOR HOTEL ASSOCIATES</u>	Owner (if different from Applicant) Name Address City, State & Zip	Cost Of Work: \$ <u>482,600</u> C of O Fee: \$ <u>75</u> Total Fee: \$ <u>4921</u>
Current legal use (i.e. single family) <u>HOTEL</u> If vacant, what was the previous use? <u>—</u> Proposed Specific use: <u>HOTEL</u> Is property part of a subdivision? <u>NO</u> If yes, please name <u>—</u> Project description: <u>INTERIOR RENOVATION TO EXISTING HOTEL LOBBY, DINING AREA + PHASE I of PLANS.</u>		
Contractor's name: <u>ALLIE/COOK CONSTRUCTION</u> Address: <u>P.O. Box 1396</u> City, State & Zip: <u>PORTLAND ME 04101</u> Who should we contact when the permit is ready: <u>PAUL LALIBERTE</u> Mailing address: <u>SAME</u>		Telephone: <u>772-2888</u> Telephone: <u>772-2888</u> <u>415-6352</u>

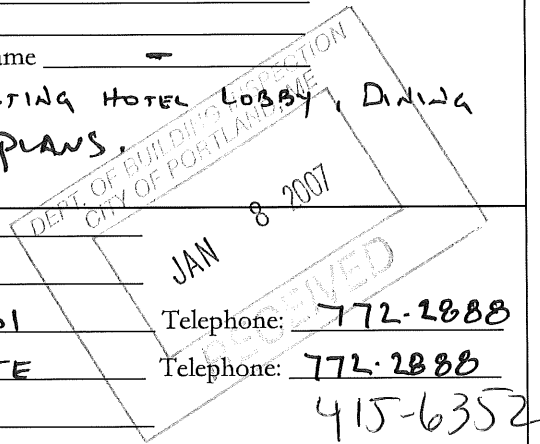

Please submit all of the information outlined on the applicable Checklist. Failure to do so will result in the automatic denial of your permit.

In order to be sure the City fully understands the full scope of the project, the Planning and Development Department may request additional information prior to the issuance of a permit. For further information or to download copies of this form and other applications visit the Inspections Division on-line at www.portlandmaine.gov, or stop by the Inspections Division office, room 315 City Hall or call 874-8703.

I hereby certify that I am the Owner of record of the named property, or that the owner of record authorizes the proposed work and that I have been authorized by the owner to make this application as his/her authorized agent. I agree to conform to all applicable laws of this jurisdiction. In addition, if a permit for work described in this application is issued, I certify that the Code Official's authorized representative shall have the authority to enter all areas covered by this permit at any reasonable hour to enforce the provisions of the codes applicable to this permit.

Signature: [Signature] Date: 8 JANUARY 2008

This is not a permit; you may not commence ANY work until the permit is issue

125

DESIGN CONTRACT :

KEVIN GAUGH 772-6022
ARCHETYPE



Certificate of Design Application

From Designer:

ARCHETYPE P.A ARCHITECTS

Date:

8 JAN 2008

Job Name:

PORTLAND HARBOR HOTEL

Address of Construction:

456-458 FOLE ST.

2003 International Building Code

Construction project was designed to the building code criteria listed below:

Building Code & Year IBC 2003 Use Group Classification (s) R-1

Type of Construction I-B

Will the Structure have a Fire suppression system in Accordance with Section 903.3.1 of the 2003 IRC YES / EXISTING

Is the Structure mixed use? NO If yes, separated or non separated or non separated (section 302.3) _____

Supervisory alarm System? YES Geotechnical/Soils report required? (See Section 1802.2) N/A

Structural Design Calculations

_____ Submitted for all structural members (106.1 – 106.11)

Design Loads on Construction Documents (1603)

Uniformly distributed floor live loads (7603.11, 1807)

Floor Area Use	Loads Shown
_____	_____
_____	_____
_____	_____
_____	_____
_____	_____

Wind loads (1603.1.4, 1609)

- _____ Design option utilized (1609.1.1, 1609.6)
- _____ Basic wind speed (1809.3)
- _____ Building category and wind importance Factor, w_p (table 1604.5, 1609.5)
- _____ Wind exposure category (1609.4)
- _____ Internal pressure coefficient (ASCE 7)
- _____ Component and cladding pressures (1609.1.1, 1609.6.2.2)
- _____ Main force wind pressures (7603.1.1, 1609.6.2.1)

Earth design data (1603.1.5, 1614-1623)

- _____ Design option utilized (1614.1)
- _____ Seismic use group ("Category")
- _____ Spectral response coefficients, S_D & S_{D1} (1615.1)
- _____ Site class (1615.1.5)

- _____ Live load reduction
- _____ Roof *live* loads (1603.1.2, 1607.11)
- _____ Roof snow loads (1603.7.3, 1608)
- _____ Ground snow load, P_g (1608.2)
- _____ If $P_g > 10$ psf, flat-roof snow load P_f
- _____ If $P_g > 10$ psf, snow exposure factor, C_e
- _____ If $P_g > 10$ psf, snow load importance factor, I_s
- _____ Roof thermal factor, C_t (1608.4)
- _____ Sloped roof snowload, P_s (1608.4)
- _____ Seismic design category (1616.3)
- _____ Basic seismic force resisting system (1617.6.2)
- _____ Response modification coefficient, R , and deflection amplification factor C_d (1617.6.2)
- _____ Analysis procedure (1616.6, 1617.5)
- _____ Design base shear (1617.4, 1617.5.1)

Flood loads (1803.1.6, 1612)

- _____ Flood Hazard area (1612.3)
- _____ Elevation of structure

Other loads

- _____ Concentrated loads (1607.4)
- _____ Partition loads (1607.5)
- _____ Misc. loads (Table 1607.8, 1607.6.1, 1607.7, 1607.12, 1607.13, 1610, 1611, 2404)



Certificate of Design

Date: 8 Jan 2008

From: ARCHETYPE PA

These plans and / or specifications covering construction work on:

INTERIOR RENOVATION PORTLAND HARBOR HOTEL

Have been designed and drawn up by the undersigned, a Maine registered Architect / Engineer according to the *2003 International Building Code* and local amendments.

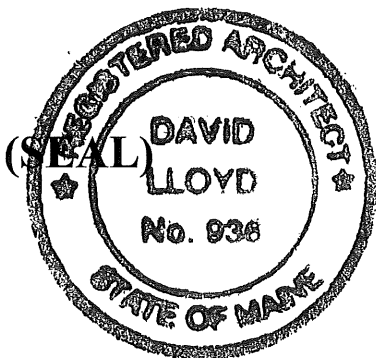

Signature: [Handwritten Signature]

Title: ARCHITECT

Firm: ARCHETYPE PA

Address: 48 Union Wharf
Portland ME 04101

Phone: 772-6022

For more information or to download this form and other permit applications visit the Inspections Division on our website at www.portlandmaine.gov

**Portland Harbor Hotel
468 Fore Street
Portland, ME 04101**

1/8/08

City Of Portland
389 Congress Street
Portland, ME 04101

Re: Building Permit for the renovations at the Portland Harbor Hotel

To Whom It May Concern:

Per the request of the City of Portland, I David Bateman, a member of the Portland Harbor Hotel certify that the Portland Harbor Hotel was constructed in 2001. I further certify that no asbestos was used in the construction of the Hotel and that no asbestos is currently present in the Portland Harbor Hotel.

Sincerely



David Bateman
Member Portland Harbor Hotel

IMPORTANT:
THESE INSTRUCTIONS ARE TO REMAIN
WITH THE HOMEOWNER.

FOR YOUR SAFETY

WARNING: If the information in this manual is not followed exactly, a fire or explosion may result causing property damage, personal injury or loss of life.

-- Do not store or use gasoline or other flammable vapours and liquids in the vicinity of this or any other appliance.

-- WHAT TO DO IF YOU SMELL GAS

- Do not try to light any appliance.
- Do not touch any electrical switch; do not use any phone in your building.
- Immediately call your gas supplier from a neighbour's phone. Follow the gas supplier's instructions.
- If you cannot reach your gas supplier, call the fire department.

-- Installation and service must be performed by a qualified installer, service agency or the gas supplier.

This appliance may be installed in an after-market permanently located, manufactured home (USA only) or mobile home, where not prohibited by local codes.

This appliance is only for use with the type of gas indicated on the rating plate. This appliance is not convertible for use with other gases, unless a certified kit is used.



**TOWN & COUNTRY
FIREPLACES™**

**TC36 & TC36 ARCH
INSTALLATION
AND OPERATING
INSTRUCTIONS**



**MODEL TC36 & TC36AR
SERIES C
MODULAR DIRECT VENT
FIREPLACE**



Contents

CAUTION.....	3
SAFETY	3
Important Note for the Commonwealth of Massachusetts:	4
INSTALLATION REQUIREMENTS	5
LOCATING THE FIREPLACE	5
TOP STANDOFFS.....	5
FRAMING AND FINISHING	7
MINIMUM COMBUSTIBLE FRAMING DIMENSIONS.....	9
MAESTRO CONTROL SYSTEM.....	10
CONVERSION TO PROPANE.....	12
HEARTH EXTENSION	19
VENTING.....	19
WALL TERMINATION VENTING	19
ROOF TERMINATION VENTING	24
VENT TERMINAL CLEARANCE	26
VENT PIPE SEALANT.....	27
INSULATED COLLAR SHIELD	27
VENT RESTRICTOR ADJUSTMENT.....	28
MANUFACTURED (MOBILE) HOME	28
GAS SUPPLY	29
WINDOW FRAME REMOVAL.....	29
FIREBOX PANELS INSTALLATION.....	30
FIRST FIRE	31
LIGHTING INSTRUCTIONS	31
APPENDIX A.....	32
MAINTENANCE	32
POWER VENT WIRING DIAGRAM	33
TC36 & TC36 ARCH REPLACEMENT PARTS	34
TC36 ARCH SPECIFIC REPLACEMENT PARTS.....	35
REPLACEMENT PARTS - MAESTRO CONCEALED VALVE	36
ROOF TERMINATION KIT.....	37
WALL TERMINATION KIT	37
WALL SHIELD/CEILING FIRESTOP THIMBLE.....	37
VENT PIPE DIMENSIONS.....	38
VENT OFFSET CHART	39
SAFETY LABEL LOCATION.....	43

CAUTION

FOR YOUR SAFETY - Do not install or operate your Town and Country fireplace without first reading and understanding this manual. Any installation or operational deviation from the following instructions voids the Town and Country Fireplaces™ Warranty and may prove hazardous.

This appliance and its individual shutoff valve must be disconnected from gas supply piping system during any pressure testing of that system at test pressures in excess of 1/2 psig (3.5 kPa).

This appliance must be isolated from the gas supply piping system by closing its individual manual shutoff valve during any pressure testing of the gas supply piping system at test pressures equal to or less than 1/2 psig (3.5 kPa).

Note: When lit for the first time, the appliance will emit a slight odour for a couple of hours. This is due to the curing of paints, sealants and lubricants used in the manufacturing process. This condition is temporary. Open doors and windows to ventilate area. Smoke and fumes caused by the curing process may cause discomfort to some individuals.

Do not use the fireplace if any part has been under water. Immediately call a qualified service technician to inspect the fireplace and to replace any part of the control system and any gas control which has been under water.

SAFETY

Due to high temperatures, this gas appliance should be located out of traffic and away from furniture and draperies.

Children and adults should be alerted to the hazards of high surface temperatures and should stay away to avoid burns or clothing ignition.

Young children should be carefully supervised when they are in the same room as the appliance.

Clothing or other flammable material should not be placed on or near the appliance.

Any grill, panel or door removed for servicing the unit must be replaced prior to operating. Failure to do so may create a hazardous condition.

Installation and repair should be done by a qualified service person. The appliance should be inspected before use and at least annually by a professional service person. More frequent cleaning may be required due to excessive lint from carpeting, bedding material, etc. It is imperative that control compartments, burners and circulating air passageways of the appliance be kept clean.

It is our policy that no responsibility is assumed by the Company or by any of its employees or representatives for any damages caused by an inoperable, inadequate, or unsafe condition which is the result, either directly or indirectly, of any improper operation or installation procedures.

Fig # 1 TC36 & TC36 ARCH FIREPLACE DIMENSIONS

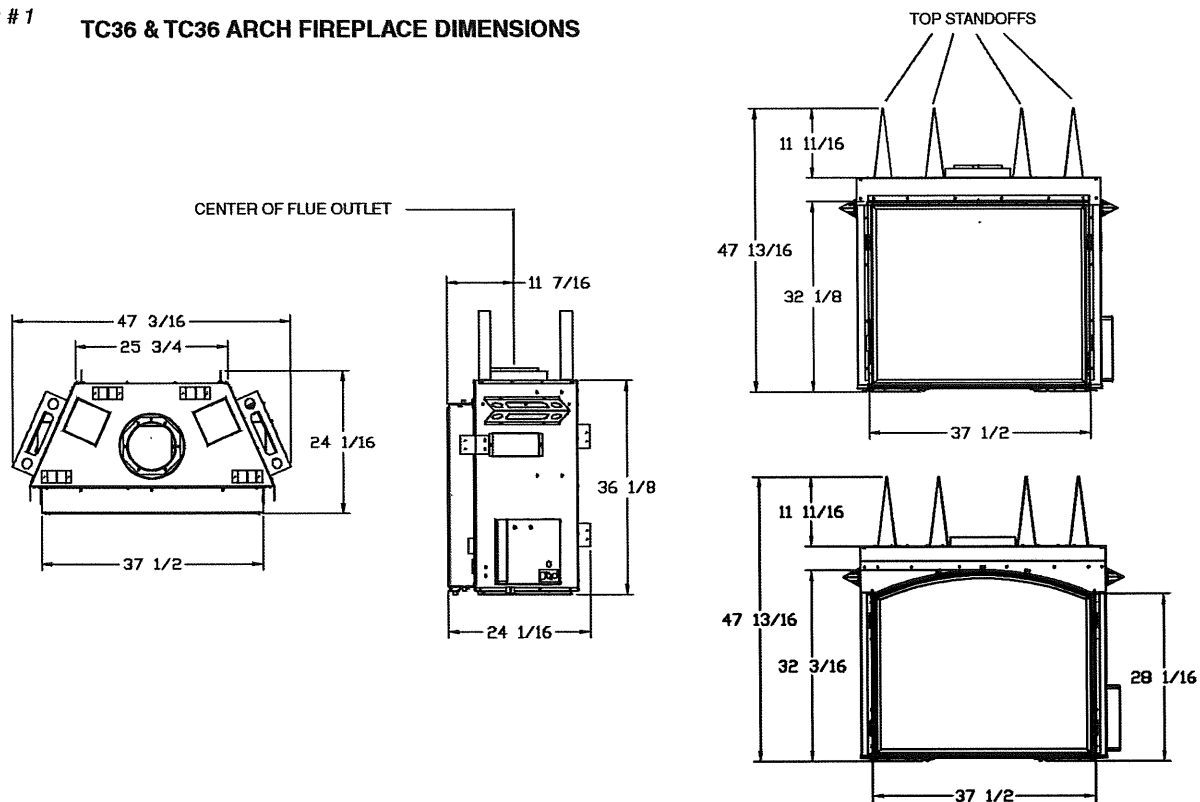

Important Note for the Commonwealth of Massachusetts:

From Massachusetts Rules and Regulations 248 CMR 5.08:

(a) For all side wall horizontally vented gas fuelled equipment installed in every dwelling, building or structure used in whole or in part for residential purposes, including those owned or operated by the Commonwealth and where the side wall exhaust vent termination is less than seven (7) feet above finished grade in the area of the venting, including but not limited to decks and porches, the following requirements shall be satisfied.

1. **INSTALLATION OF CARBON MONOXIDE DETECTORS.** At the time of installation of the side wall horizontal vented gas fuelled equipment, the installing plumber or gasfitter shall observe that a hard wired carbon monoxide detector with an alarm and battery back-up is installed on the floor level where the gas equipment is to be installed, in addition, the installing plumber or gasfitter shall observe that a battery operated or hard-wired carbon monoxide detector with an alarm is installed on each additional level of the dwelling, building or structure served by the side wall horizontal vented gas fuelled equipment. It shall be the responsibility of the property owner to secure the services of qualified licensed professionals for the installation of hard-wired carbon monoxide detectors.

a. In the event that the side wall horizontally vented gas fuelled equipment is installed in a crawl space or an attic, the hard-wired carbon monoxide detector with alarm and battery back-up may be installed on the next adjacent floor level.

b. In the event that the requirements of this subdivision cannot be met at the time of completion of installation, the owner shall have a period of thirty (30) days to comply with the above requirements; provided, however, that during said thirty (30) day period, a battery operated carbon monoxide detector with an alarm shall be installed.

2. **APPROVED CARBON MONOXIDE DETECTORS.** Each carbon monoxide detector as required in accordance with the above provisions shall comply with NFPA 720 and be ANSI/UL 2034 listed as IAS certified.

3. **SIGNAGE.** A metal or plastic identification plate shall be permanently mounted to the exterior of the building at a minimum height of eight (8) feet above grade directly in line with the exhaust vent terminal for the horizontally vented gas fuelled heating appliance or equipment. The sign shall read, in print size no less than one-half (1/2) inch in size, "GAS VENT DIRECTLY BELOW. KEEP CLEAR OF ALL OBSTRUCTIONS".

4. **INSPECTION.** The state or local gas inspector of the side wall horizontally vented gas fuelled equipment shall not approve the installation unless, upon inspection, the inspector observes carbon monoxide detectors and signage installed in accordance with the provisions of 248 CMR 5.089(2)(a) 1 through 4.

(b) **EXEMPTIONS.** The following equipment is exempt from 248 CMR 5.089(2)(a) 1 through 4.

1. The equipment listed in Chapter 10 entitled "Equipment Not Required To Be Vented" in the most current edition of NFPA 54 as adopted by the Board; and
2. Product Approved side wall horizontal vented gas fuelled equipment installed in a room or structure separate from the dwelling, building or structure used in whole or in part for residential purposes.

(c) **MANUFACTURER REQUIREMENTS – GAS EQUIPMENT VENTING SYSTEM PROVIDED.** When the manufacturer of Product Approved side wall horizontally vented gas equipment provides a venting system design or venting system components with the equipment, the instructions provided by the manufacturer for installation of the equipment and the venting system shall include:

1. Detailed instructions for the installation of the venting system design or the venting system components; and
2. A complete parts list for the venting system design or venting system.

(d) **MANUFACTURER REQUIREMENTS – GAS EQUIPMENT VENTING SYSTEM NOT PROVIDED.** When the manufacturer of a Product Approved side wall horizontally vented gas fuelled equipment does not provide the parts for venting the fuel gases, but identifies "special venting systems", the following requirements shall be satisfied by the manufacturer.

1. The referenced "special venting system" instructions shall be included with the appliance or equipment installation instructions; and
2. The "special venting systems" shall be Product Approved by the Board, and the instructions for that system shall include a parts list and detailed installation instructions.

(e) A copy of all installation instructions for all Product Approved side wall horizontally vented gas fuelled equipment, all venting instructions, all parts lists for venting instructions, and/or all venting design instructions shall remain with the appliance or equipment at the completion of the installation.

INSTALLATION REQUIREMENTS

The Town & Country Fireplace installation and venting must conform to the current CAN/CGA-B149 installation code (in Canada) or the current National Fuel Gas Code, ANSI Z223.1 (in the USA), and approved per local codes. Only qualified (licensed or trained) personnel should install this product.

In the state of Massachusetts, only a licensed Plumber and Gas Fitter may install this product.

LOCATING THE FIREPLACE

In planning the installation for the fireplace, it is necessary to determine where the unit is to be installed, location of vent system and where gas supply piping may be plumbed. Various installations are possible, such as, into an existing wall, a corner, a built-in wall or a wall projection (see Fig. #5). Due to high temperatures, do not locate this fireplace in areas of high traffic or near furniture or draperies.

The minimum clearances from the fireplace to combustible surfaces must be adhered to and are shown on Fig. #2 and 3.

TOP STANDOFFS

The top standoffs are shipped loose inside the fireplace, see window frame removal on page 28, and must be installed on top of the fireplace as shown in fig. #4. Do this once the fireplace is on site and in position.

Fig. # 4

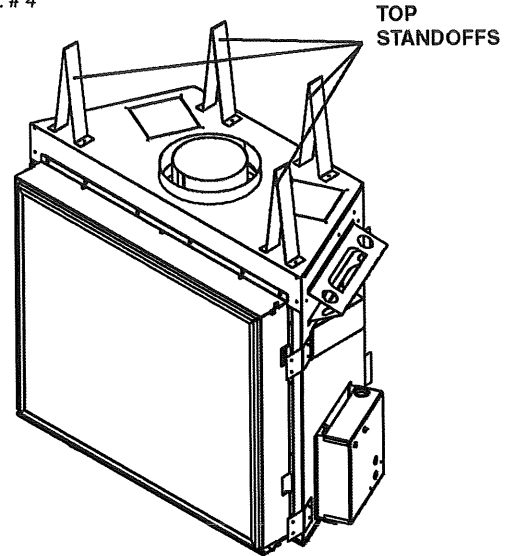

Fig. # 5

Examples of Common Locations

SEE FIG #9 FOR DIMENSIONS

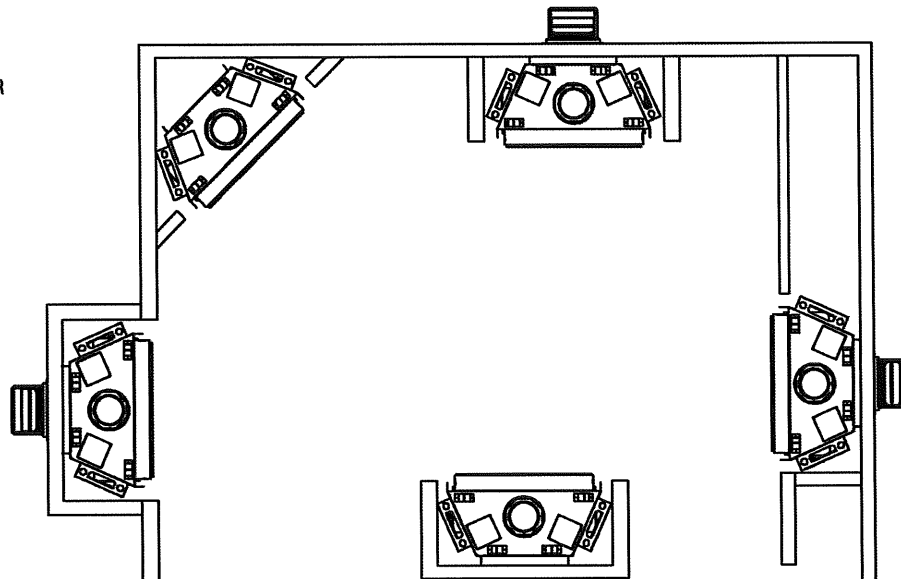
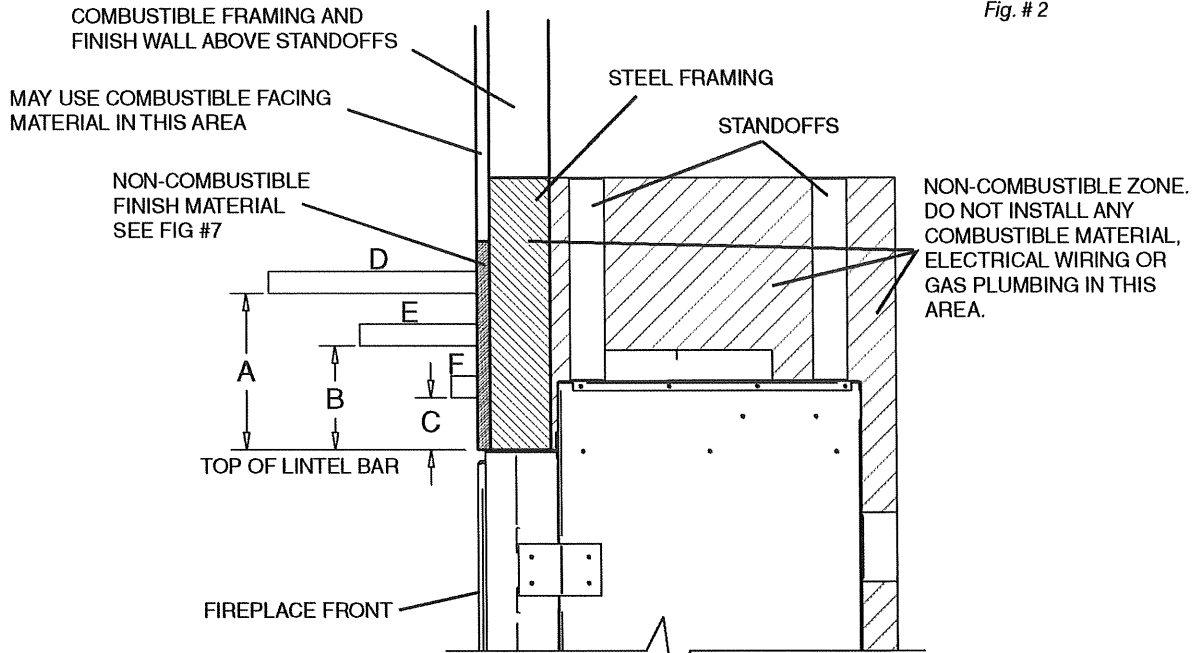

Fig. # 2



MANTEL CLEARANCE CHART			
REF.	* MANTEL CLEARANCE	REF.	** MANTEL DEPTH
A	9"	D	12"
B	6"	E	6 3/4"
C	3"	F	1 1/2"

Minimum Clearances to Combustibles:

Side standoffs.....	0 in.	(0 mm)
Back standoffs.....	0 in.	(0 mm)
Top standoffs.....	0 in.	(0 mm)
Bottom of appliance.....	0 in.	(0 mm)
Adjacent sidewall.....	4 in.	(102 mm)
Ceiling to appliance.....	24 in.	(610 mm)
*Mantel to appliance.....	See Figure #2	
**Maximum Mantel extension.....	See Figure #2	
Mantel support.....	4 in.	(102 mm)
Vertical vent pipe.....	1-3/4 in.	(45 mm)
Horizontal vent pipe		
Top.....	1-3/4 in.	(45 mm)
Sides.....	1-3/4 in.	(45 mm)
Bottom.....	1-3/4 in.	(45 mm)

Fig. # 3

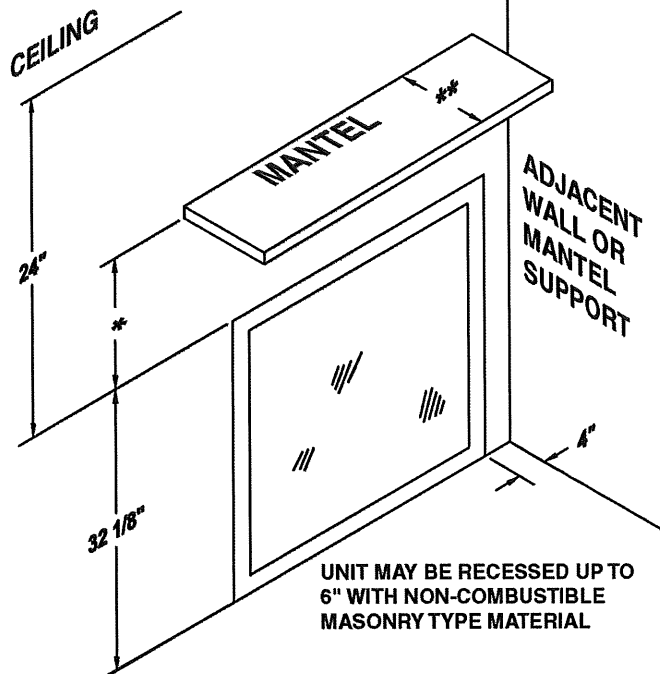

FRAMING AND FINISHING

Note: The fireplace should be in place and venting installed before framing in or building an enclosure around the unit.

The Town & Country Fireplace must be framed in as described below or totally enclosed with non-combustible material, such as facing brick.

Determine the total thickness of facing material to be used. A thickness of 3/4" will allow the finishing surface to be flush with the front of the unit. If preferred, additional masonry type non-combustible material can be installed above and to the sides up to 6 inches proud of the appliance. **Finishing material must not interfere with glass frame access or operation. The gap between the frame and the top and side lintel bars must be maintained for proper operation of the window latching mechanism.**

A Steel Stud Framing Kit is supplied with the fireplace and must be used unless the fireplace is totally enclosed with non-combustible material. Assemble the framing kit as per it's instructions. Attach the steel frame to the fireplace once

the fireplace is in its final position. Secure the steel frame to the framing brackets on each side of the unit. Ensure that the studs are set back far enough to allow for thickness of finishing surface.

The sides, back and top of the fireplace can be framed in up to the steel studs and the fireplace standoffs using conventional lumber. Consult local building codes for specific requirements.

Due to high temperatures, concrete board is supplied with the fireplace and must be used to sheet in the front of the fireplace, extending 12" above and 4 1/2" to the side of the framing edge bars. See figure #7. Standard sheetrock (drywall) may be used beyond this.

Chase Insulation: When installing this fireplace against a non-insulated exterior wall or chase, it is recommended that the outer walls be insulated to same degree as other exterior walls. Do not place fireplace directly against the insulation. Cover the insulation and plastic vapour barrier with a solid surface, such as drywall (sheetrock). Consult local codes. Do not insulate or use plastic vapour barrier within the framing kit.

Fig. # 6

NON-COMBUSTIBLE ZONE. DO NOT INSTALL ANY COMBUSTIBLE MATERIAL, ELECTRICAL WIRING, INSULATION, PLASTIC VAPOUR BARRIER OR GAS PLUMBING WITHIN THE STEEL STUD FRAMING

STEEL STUD FRAMING KIT DIMENSIONS (TC36.BFRKITA)

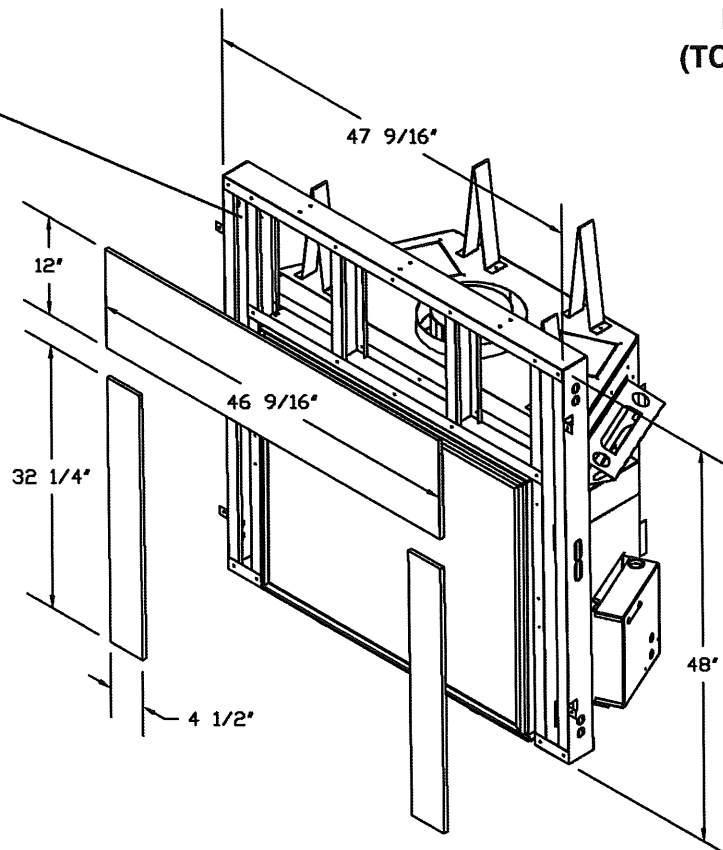

ALL OTHER FRAMING CAN BE DONE WITH CONVENTIONAL LUMBER

Fig. # 7

CONCRETE BOARD DETAIL

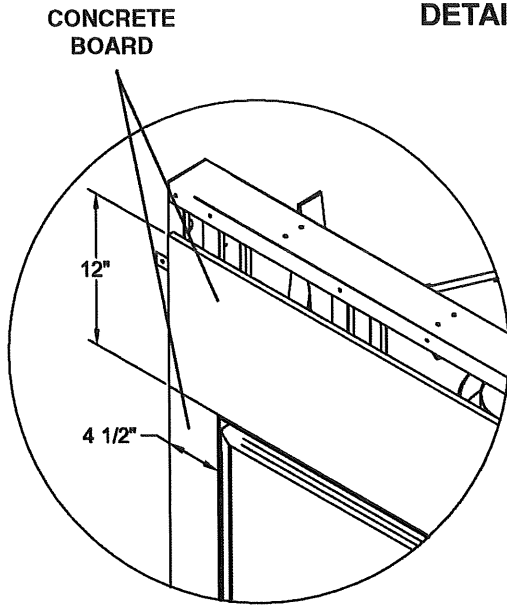

Concrete board (or other non-combustible material) must extend 12" above and 4 1/2" to the sides of the framing edges.

ARCH CONCRETE BOARD DETAIL

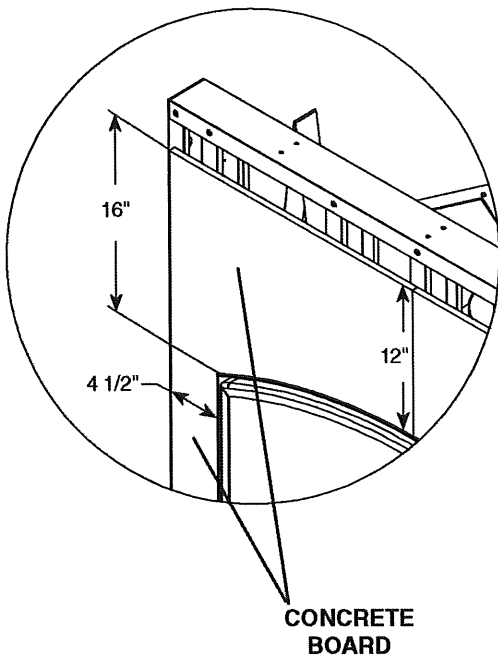

Fig. # 8

NON-COMBUSTIBLE RECESSED INSTALLATION DETAIL

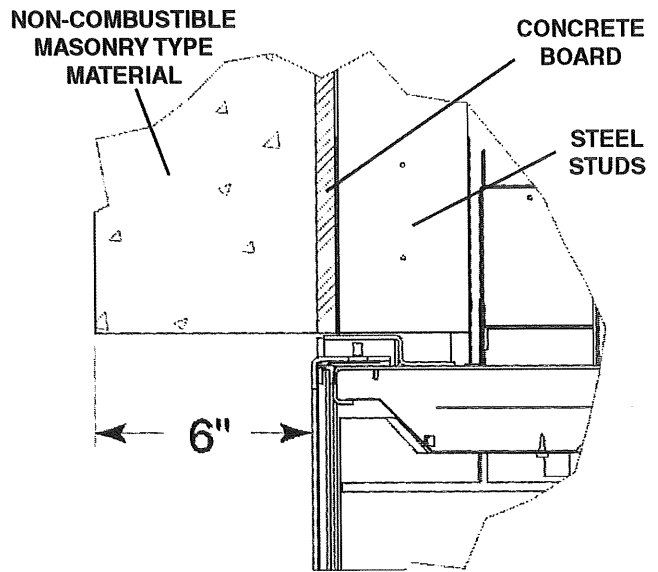
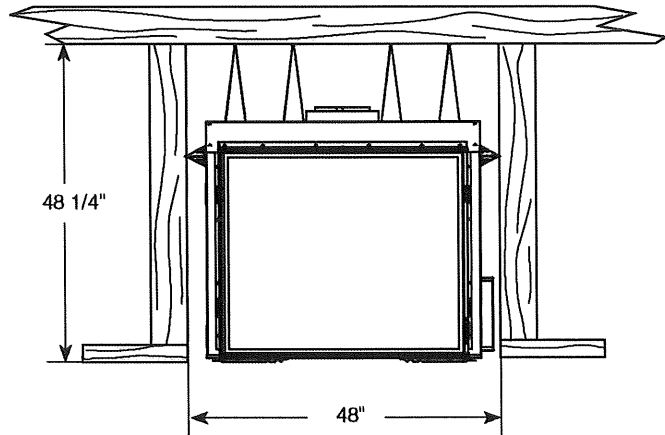
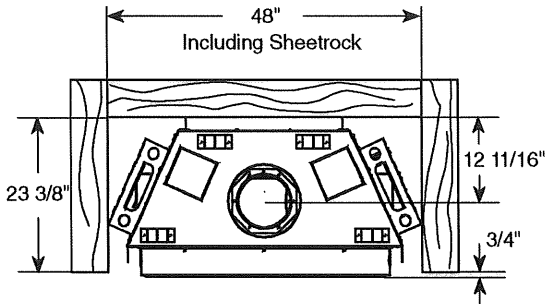
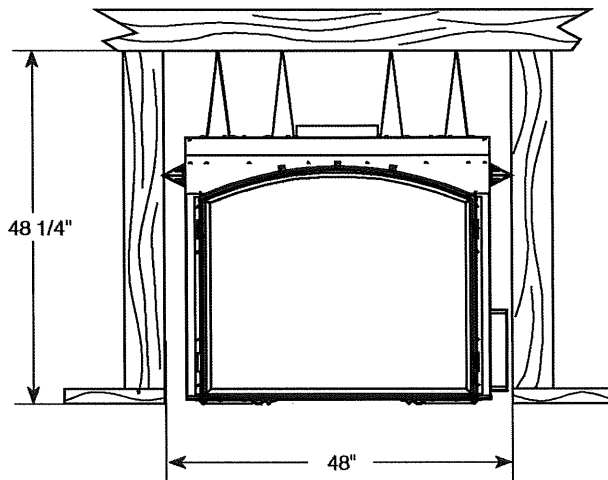
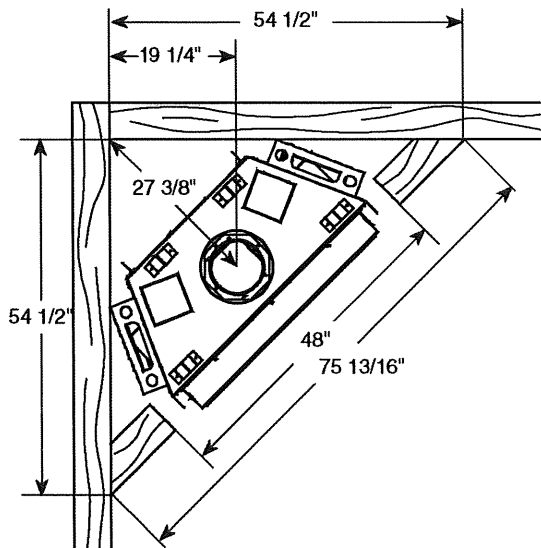

Fig. # 9

MINIMUM COMBUSTIBLE FRAMING DIMENSIONS



WARNING: Fireplace should be in its final location before framing.



MAESTRO CONTROL SYSTEM

The gas control system is located on the right hand side of the firebox behind an access panel and the decorative brick panel. The fireplace is operated via a wall switch that can be located up to 25 ft away from the fireplace and also by a hand held remote control unit.

Installation

- 1) Locate the fireplace in the desired location.
- 2) Remove access panel from right hand side of the firebox (Fig. #10)

Fig. # 10

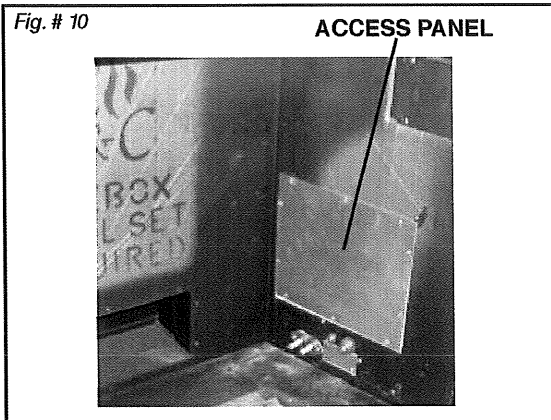

Fig. # 12

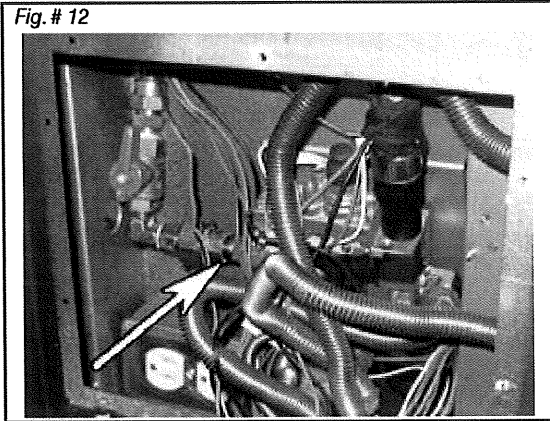
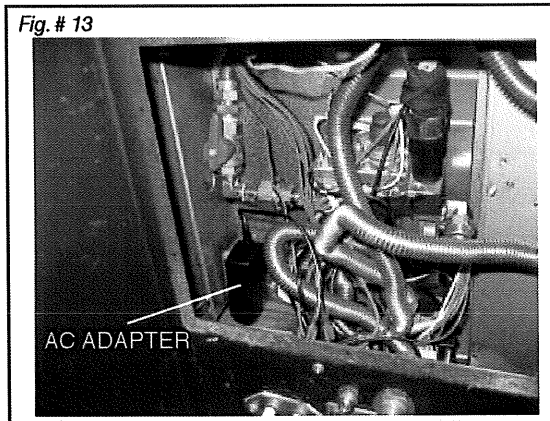
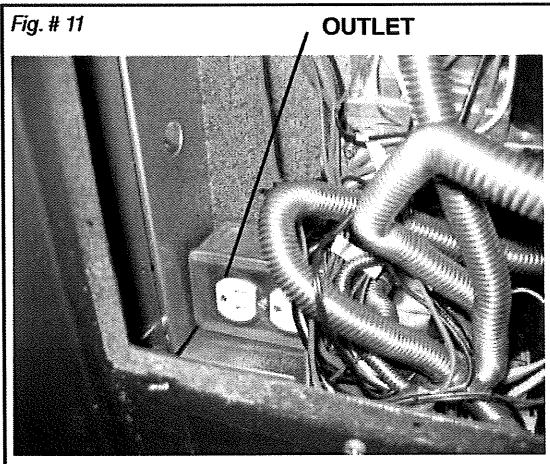

Fig. # 13



- 3) Connect a 110v AC electrical supply to the outlet installed inside the control box (Fig. #11)

Fig. # 11



- 7) Route the control cable as required to the wall control electrical box.
- 8) Attach the control cable to the wall control. (Fig. #14)
- 9) Insert the 4 supplied "AA" batteries into the battery pack and connect to wall control. (Fig. #15)
- 10) Fasten the wall switch to the electrical box.
- 11) Fasten the faceplate to switch
- 12) Turn on the gas supply and check that all connections are tight and leak free.

- 4) Connect the gas supply to the valve (Fig. #12)
- 5) Plug the A/C adaptor into the outlet (Fig. #13)
- 6) Attach the electrical box for the supplied wall control to the framing in the desired location (up to 25ft away).

Fig. # 14

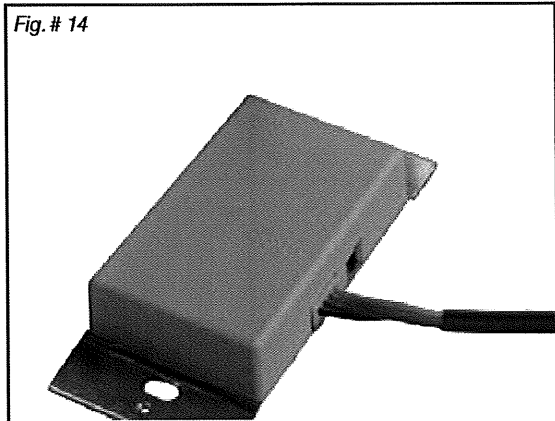
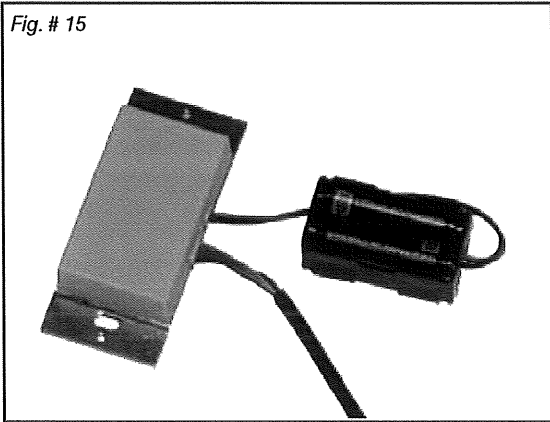

Fig. # 15



Burner installation

- 1) Remove the burner from the packaging and install as per its installation instructions.
- 2) Connect the flex hoses from the pilot and the main burner supply to the bulkhead fittings on the firebox. (Fig. #16)
- 3) Connect the electrical connections from the pilot assembly to the connections in the firebox side. Ensure that the orange wire from the spark electrode is connected to the rear of the two connectors in the bulkhead. (Fig. #17)

Note: If you need to test the supply pressure, turn off the gas supply before removing the blanking plug from the supply pressure test port.

Fig. # 17

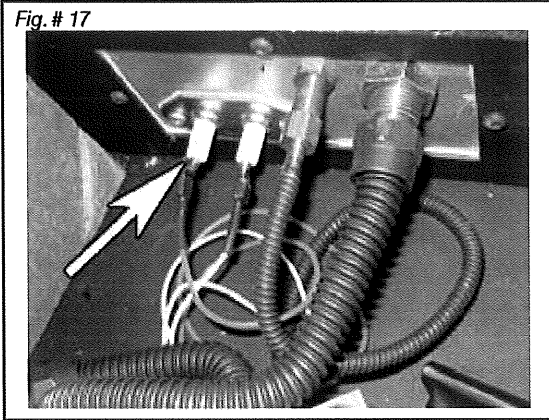

- 4) Remove the pressure test point pipe plug from the manifold test port. The plug is located between the right side lintel and firebox side. (Fig. #18)
- 5) Thread the extension piece into the open test port. (Fig. #19)
- 6) Attach a pressure gauge onto the hose barb on the now installed extension piece.

Fig. # 18

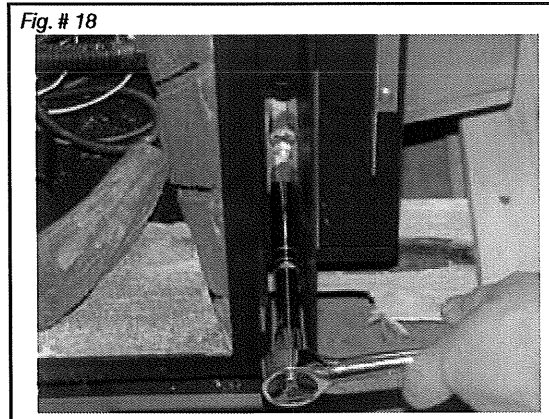

Fig. # 19

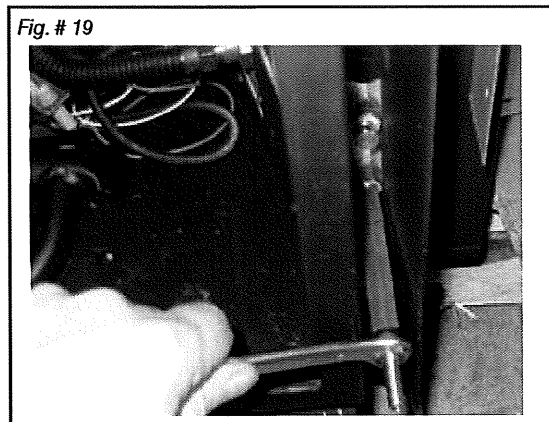
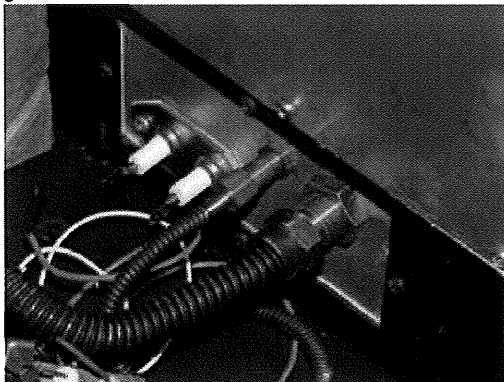

Fig. # 16



If this fireplace is to be used on Natural Gas go to step 17.

CONVERSION TO PROPANE

If the unit is to be used on propane convert as follows using the components supplied with this fireplace:

Warning:

This conversion kit shall be installed by a qualified service agency in accordance with the manufacturer's instructions and all applicable codes and requirements of the authority having jurisdiction. If the information in these instructions is not followed exactly, a fire, explosion or production of carbon monoxide may result causing property damage, personal injury or loss of life. The qualified service agency is responsible for the proper installation of this kit. The installation is not proper and complete until the operation of the converted appliance is checked as specified in the manufacturer's instructions supplied with the kit.

Caution: The gas supply and electrical power shall be shut off before proceeding with the conversion.

- 7) On the Country Home Burner remove the two screws securing the air deflector to the grate. (Fig. #20)
- 8) Remove the manifold assembly from the burner, Country Home and Chalet burners. (Fig. #21)
The burner tube will have to be removed to expose the orifice on the Black Diamond Burner. (Fig. #22)
- 9) With a 1/2" wrench remove the natural gas orifice (#30) and replace with propane orifice (#45)
- 10) With a 7/16" wrench loosen the pilot head on the pilot assembly (Fig. #23)

COUNTRY HOME BURNER

Fig. # 20

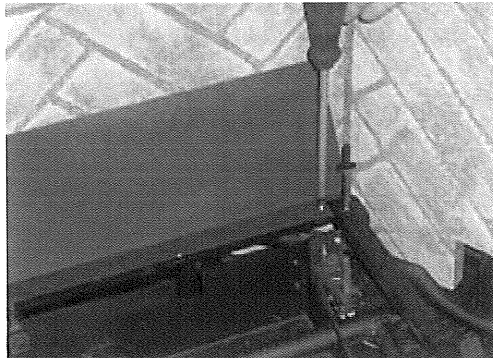

COUNTRY HOME & CHALET BURNER

Fig. # 21

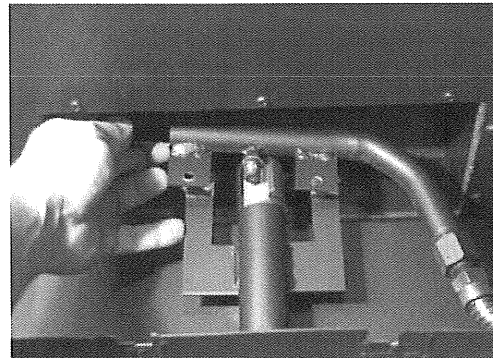

BLACK DIAMOND BURNER

Fig. # 22

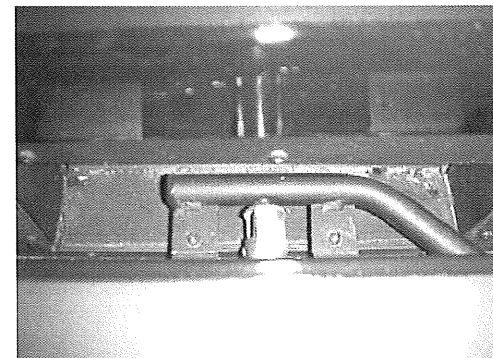

Fig. # 23

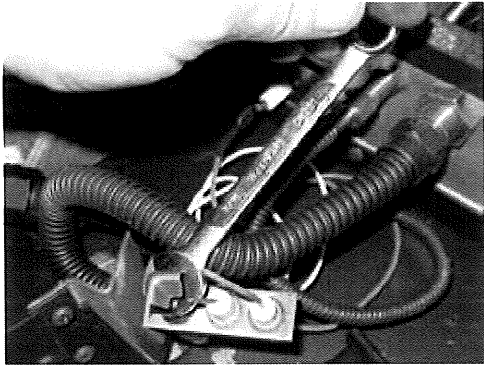

Fig. # 24

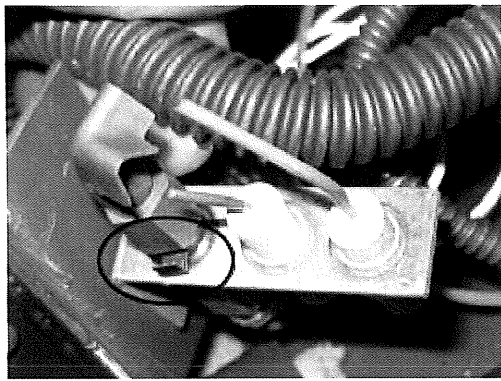
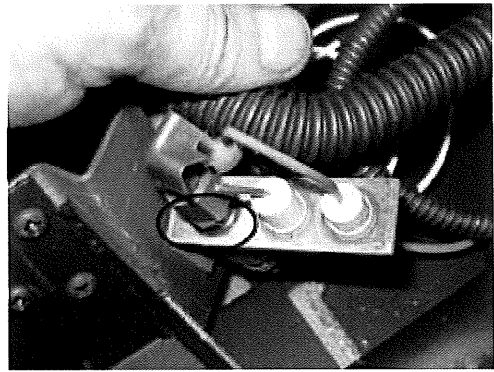

Fig. # 25



- 11) Slide the pilot adjustment band over and ensure that the hole in the orifice band is showing. (Fig. #24 shows NG position, Fig. #25 shows LP position)
- 12) Remove the minimum rate screw located in the valve. (Fig. #26)

Fig. # 26

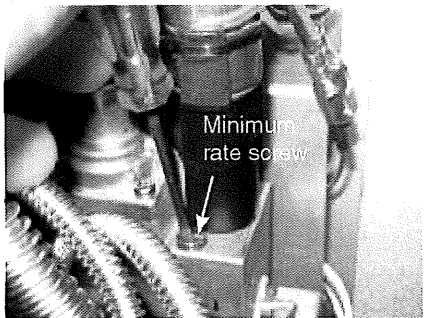
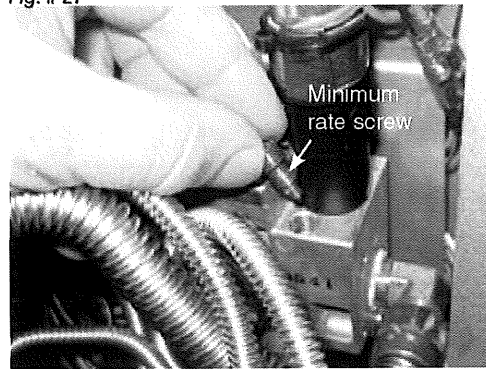
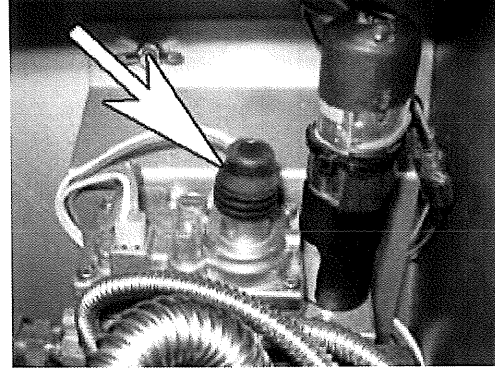

Fig. # 27



- 13) Replace the minimum rate screw with the one provided in the propane conversion kit supplied with this fireplace. Ensure that the screw is fully installed. (Fig. #27)

Fig. # 28



- 14) Pull off the rubber cap from the top of the pressure regulator. (Fig. #28) The pressure regulator adjustment tube is now accessible.

Fig. # 29

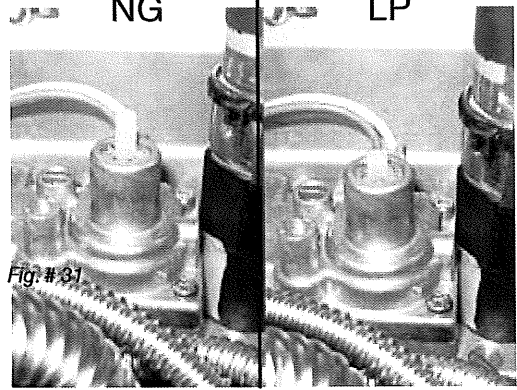

- 15) Press down on the center tube and rotate 90°. The center tube should stay down. (Fig. #29). Replace the rubber cap.

Fig. # 30

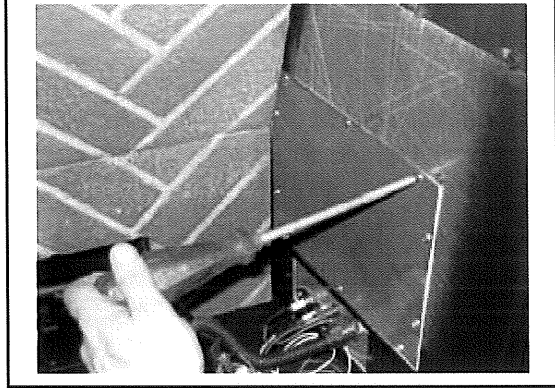

- 16) Sign and date the conversion label supplied and stick it to valve body.
- 17) Loosely attach the access panel to the side of the fire-box with a few screws. (Fig. #30)

Fig. # 31

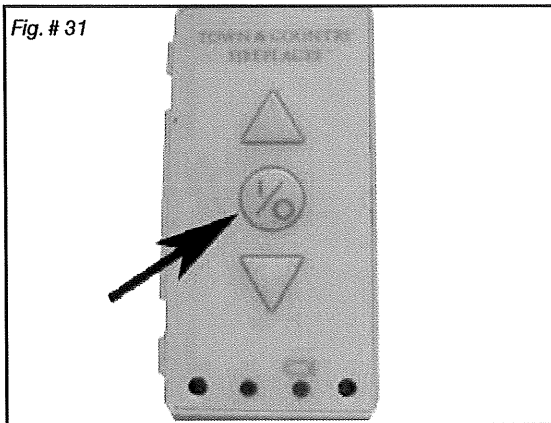

- 18) Turn on gas and electrical supplies.
- 19) Press the center button on the wall control (Fig. #31). The igniter will start to spark. After a short delay the pilot will light, followed by the main burner.

Fig. # 32

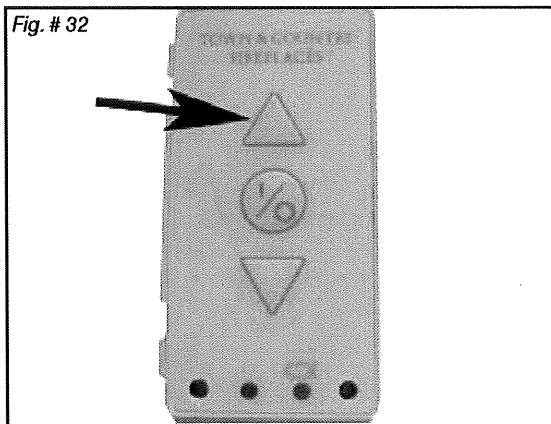

- 20) Press the up button on the wall control and hold it for 5 seconds or until a clicking sound is heard from the gas control. Release the button, check manifold pressure and ensure that it's correct. (Fig. #32)

- 21) Press the center button of the wall control. The fireplace will shut off.
- 22) Install the remaining screws in the access panel and tighten.
- 23) Remove the pressure gauge and the extension piece and thread the pressure test pipe plug into the pressure test port. Thread sealant is required on the threads.
- 24) Turn the fireplace on and verify that the connections are tight.
- 25) Continue installation of the burner as per the burner kit instructions.

Standing Pilot Function

(only for use where permitted)

The control system on this fireplace is shipped as a non-standing pilot fireplace. If required the system can be converted to a standing pilot by depressing a recessed button located on the lower right hand side of the wall control. (Fig. #33) This should be depressed with a paperclip, pencil or other thin object. Once activated the pilot will run continuously. Please check with your local inspector to ensure that this is permitted in your area.

Control System – Remote Control Initial Setup

This fireplace is supplied with a wall control and hand held remote control. **Please note only genuine Town & Country Fireplace wall controls and hand held remote controls can be used on this fireplace.**

- 1) Initial set up of the hand held remote is required. A "learn" button is located on the lower left hand side of the wall switch. This should be depressed with a paperclip, pencil or other thin object. (Fig. #34)
- 2) Once this has been pressed, press the center button on the hand held remote. (Fig. #35) The fireplace will then turn on.
- 3) Turn off the fireplace by pressing the center button again. The handset is now synchronized with the fireplace.

Fig. # 33

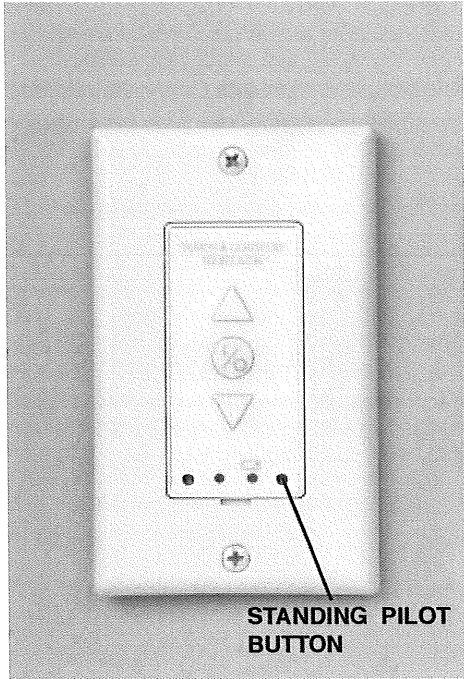

STANDING PILOT
BUTTON

Fig. # 35



ON/OFF BUTTON

Fig. # 34

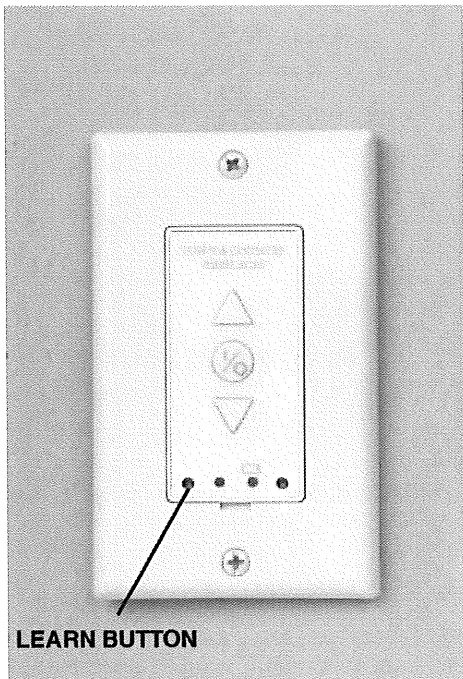

LEARN BUTTON

Fig. # 36

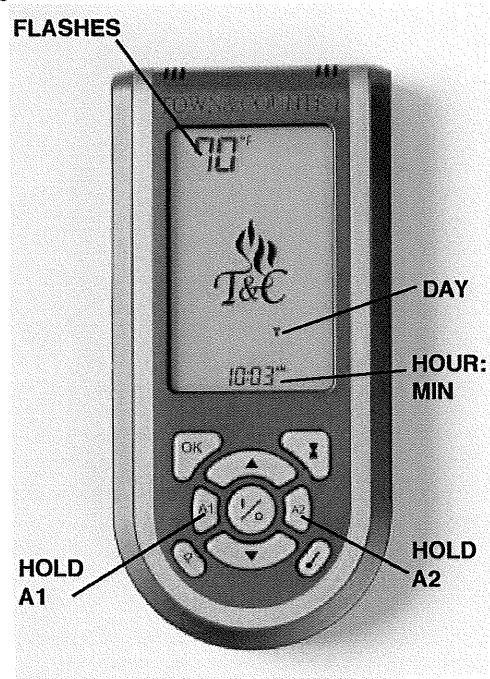

FLASHES

DAY

HOUR:
MIN

HOLD
A1

HOLD
A2

Initial Settings

(time and temperature)

- 1) Press and hold the A1 and A2 buttons at the same time until the temperature symbol flashes. (Fig. #36)
- 2) Use the up and down arrows to set preferred temperature units. (°F or °C)
- 3) Press OK and the "hour" value will start to flash.
- 4) Use the up and down arrows to set the "hour" value.
- 5) Press OK and the "minute" value will flash.
- 6) Use the up and down arrows to set the "minute" value.
- 7) Press OK and the "day" value will flash.
- 8) Use the up and down arrows to set the "day" value.

Fig. # 37

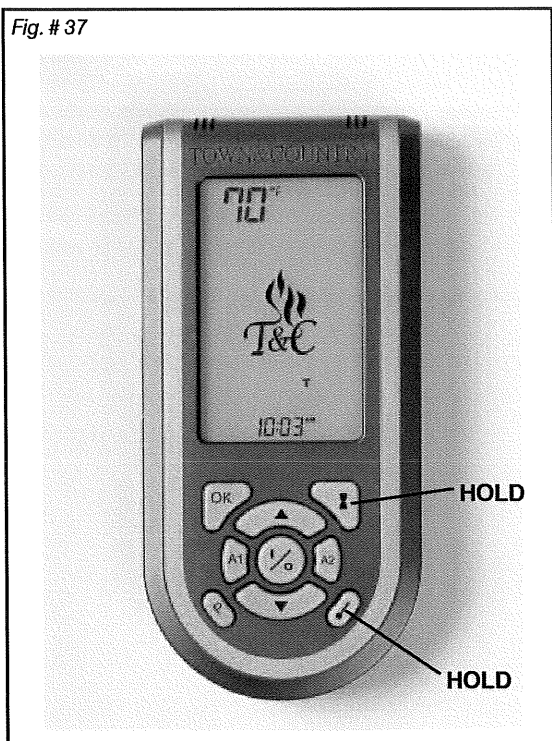

- 9) Press ok to end the initial set up.

Childproof Lock

An additional feature of this remote control is the childproof lock. To activate this system press and hold the timer and thermostat buttons for approx. 5 seconds until the "lock" symbol appears on the remote display. (Fig. #37) The remote control hand set buttons are now locked and the lock symbol will reappear every time a button is pressed on the remote control until the timer and thermostat buttons are pressed and held again.

Note: The fireplace can still be operated normally using the wall control even with the remote control buttons locked.

Control System - Operation

Each Town and Country Maestro Control system comes equipped with a manual mode on the wall control and hand held remote, and three programmable modes accessible with the hand remote.

Fig. # 38

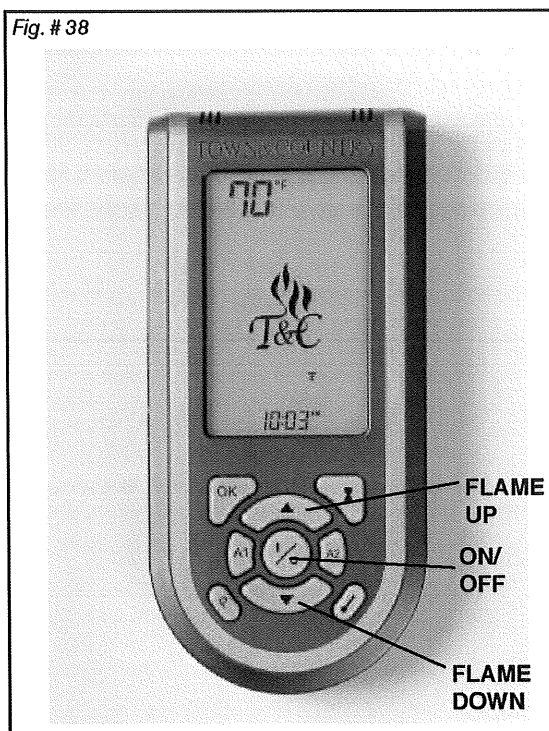

Manual Mode

(on remote and wall control)

Basic operation of the fireplace can be performed with the wall control or remote hand set. (ON/OFF, as well as flame modulation UP/ DOWN).

The center button on the remote control can be used to turn the fireplace ON and OFF. With the fireplace off, press the center button to turn it on. (The "MAN" and flame icons will be displayed on the screen) A second push will turn it off. (The "MAN" and flame icons will disappear from the screen)

When the fireplace is on, the up and down buttons located above and below the center button are used to modulate the flame height. (Fig. #38)

Countdown Timer Mode

(Operates the fireplace for a preset length of time)

- 1) Press the timer button and the time will flash on the lower center of the display. (Fig. #39)
- 2) When display is flashing, use the up and down arrows to set the length of time you would like the fireplace to run. (The range is 10 minutes minimum to 180 minutes maximum). (Fig. #41)
- 3) Press the OK button and the timer is set and the control is in countdown timer mode.
- 4) To exit the timer mode press the Program, Manual or Thermostat buttons. Please note that the first press of the Manual button will turn the fireplace off.

Program Mode

(to preset up to two on and off periods per day)

The program mode has two settings for weekdays and two for weekends. The hand held remote comes with the following pre programmed settings:

Fig. # 39

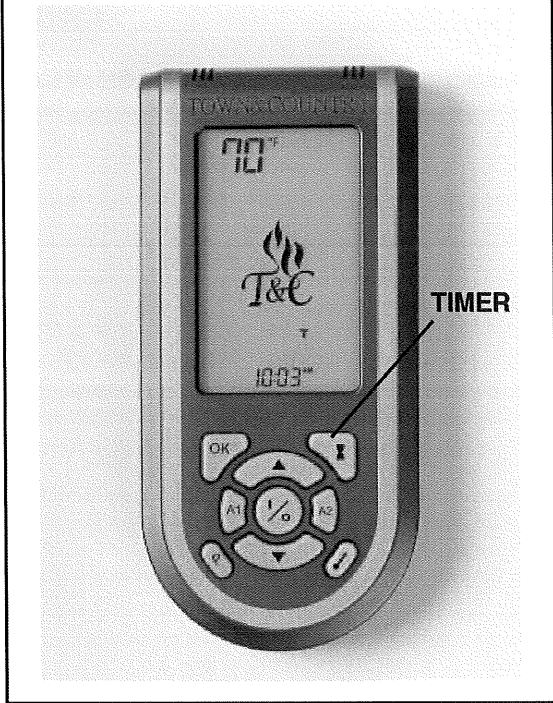

Weekday Program
(Monday through Friday)

Program one (P1) turns ON at 7:00am and turns OFF at 8:00am
 Program two (P2) turns ON at 5:00pm and turns OFF at 7:00pm

Weekend Program
(Saturday and Sunday)

Program one (P1) turns ON at 9:00am and turns OFF at 10:00am
 Program two (P2) turns ON at 6:00pm and turns OFF at 9:00pm

Activate the programs by pressing the program button on the lower left hand side of the remote hand set. (Fig. #41)
 To customize these setting:

- 1) Hold the program button down until the display flashes. (P1, weekday ON time - [Fig. #42])
- 2) Use the up and down buttons to change the time to the desired ON time.
- 3) By pressing the OK button, the P1 weekday OFF time will flash.
- 4) Use the up and down buttons to set the desired OFF time.
- 5) Press the OK button and the P2 weekday ON time will flash.

Fig. # 40

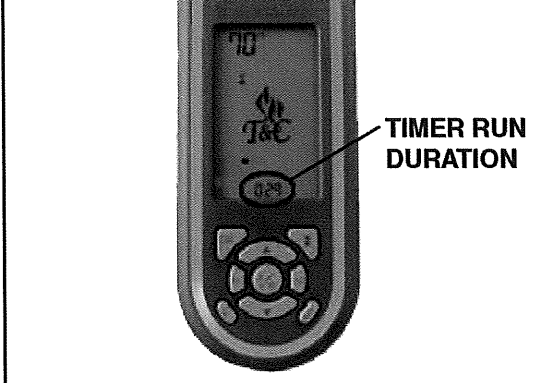
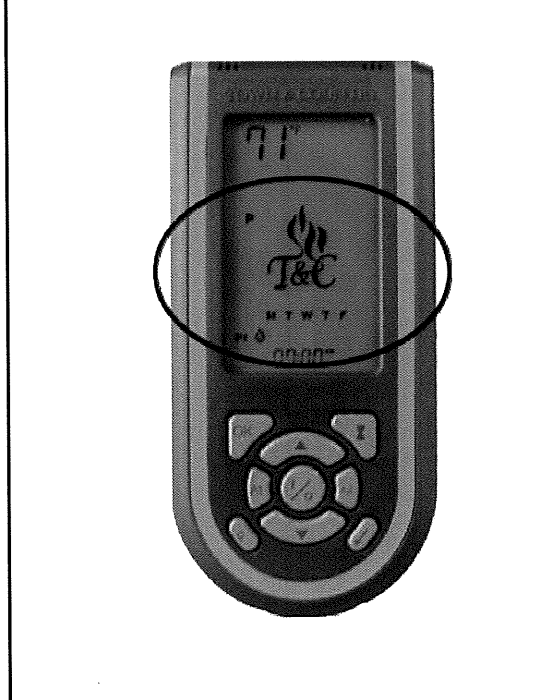

Fig. # 41



Fig. # 42



- 6) Repeat the process to set the P2 weekday, P1 weekend and P2 weekend programs.
- 7) When the P2 OFF time is set and the OK button is pressed the display will stop flashing and the remote will be in program mode.

The program settings are now stored in the remote handset and will not change unless the above process is repeated or the batteries are removed from the handset.

To switch out of program mode, simply press one of the manual, timer or thermostat mode buttons. Please note that if the manual button is pressed it will turn the fireplace off.

Thermostatic Mode (Only for use where permitted)
(Operates the fireplace within a set temperature range)

The fireplace is shipped with thermostatic mode function deactivated. If this function is permitted for use in your area it can be activated by depressing the recessed button on the **underside of the hand held remote**. (Fig. #43) Once activated, the thermostat symbol (Fig. #44) will be displayed when the thermostat button is pressed

To activate a set point temperature:

- 1) Press the thermostat button on the lower right hand side of the hand held remote to activate the thermostat mode. (Fig. #45) The temperature and thermostat symbols will appear.
- 2) Press and hold the thermostat button for 5 seconds. The temperature icon on the display will flash. (Fig. #46)
- 3) While the temperature icon is flashing use the up and down arrows to set the temperature to the desired setting.
- 4) Once the desired setting is reached, press the OK button. If the OK button is not pressed the icon will continue to flash for 5 seconds and then set itself to the temperature displayed.
- 5) The fireplace is now in thermostatic mode. To exit the thermostatic mode press the program, manual or timer buttons. Please note that the first press of the manual button will turn the fireplace off.

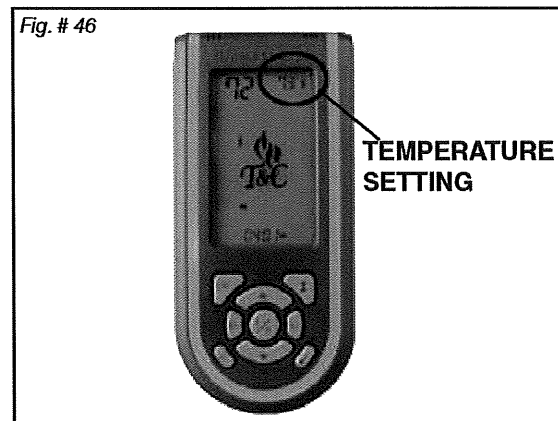
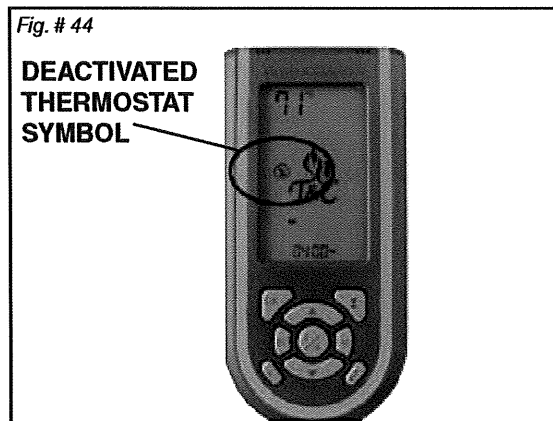
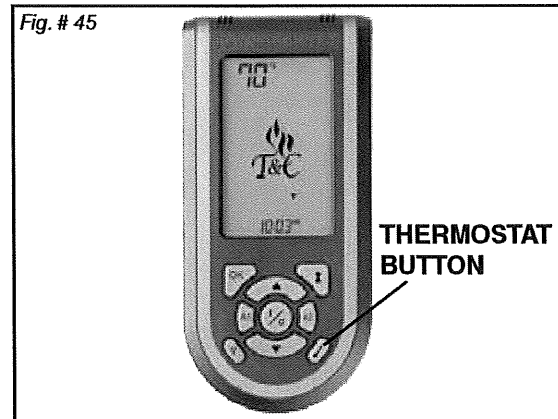
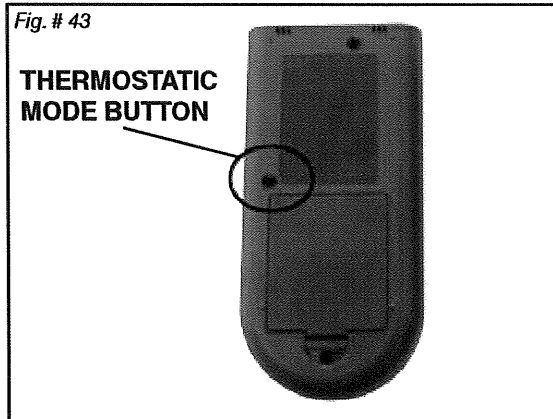

VENTING

Before installing venting for this unit, the installer should read these instructions to insure that the proper vent configuration has been selected.

Use only Town and Country Termination kits #:
TCVT.WTA - Wall Termination Kit
TCVT.RTA - Roof Termination Kit

Vent system components approved for use with the Town and Country Fireplace are shown in Fig. #49.

NOTE: Optional Power Vent (TCVT.PVA) requires different venting. Please refer to Power Vent manual.

Various combinations of vertical and horizontal runs may be used. Refer to Fig. #52 and 53 for details. For optimum performance and flame appearance, keep the vent length to a minimum and limit the number of elbows. Connections between each vent system component must be tightly joined, secured with sheet metal screws and sealed. A horizontal run of vent should have a 1/4" rise for every 1 ft. of run towards the termination.

CAUTION: UNDER NO CONDITION SHOULD COMBUSTIBLE MATERIAL BE CLOSER THAN 1 3/4 INCHES FROM THE TOP AND 1 3/4 INCHES FROM THE SIDES OF A HORIZONTAL SECTION AND 1 3/4 INCHES FROM THE VERTICAL SECTIONS OF THE VENT PIPE.

WALL TERMINATION VENTING

Exterior wall opening:

Determine the exact position of the fireplace so that the vent pipe is centred (if possible) between two building framing members. Consult your local building codes prior to proceeding. The vent kit will accommodate up to a maximum wall thickness of 12 inches.

- 1) Having determined the position of the fireplace, cut and frame a 14 1/2 inch opening centred at a minimum height of 68 1/2 inches above the floor. The opening may be round or square. Height of the opening will vary with each installation. As the horizontal vent run increases, so does the minimum vertical rise (see Fig. #52).

IMPORTANT: When locating the opening, it should be noted that vent terminal clearances must be maintained. See "Vent Terminal Clearances" section for proper clearances.

A minimum 2 foot length of pipe is required off the top of the fireplace for any wall termination. With this minimum vertical rise in combination with a 90° elbow, a maximum horizontal run of 18 inches is permitted (see Fig. #52 and 53). For longer horizontal runs greater than 18 inches, increase vertical rise appropriately.

The rise and run must be constrained to the boundaries of the chart shown in Fig. #52. The horizontal run of vent must have a 1/4" rise for every 1 ft. of run towards the termination.

Fig. # 47

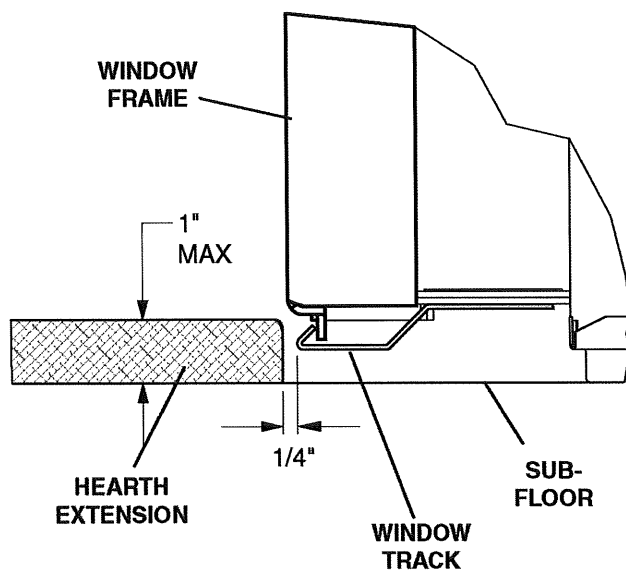

HEARTH EXTENSION

While a hearth extension is not required for this fireplace, one is recommended for aesthetic reasons. The hearth extension should be noncombustible and must not be any more than 1" above the bottom of the fireplace. If thicker, fireplace must be raised up accordingly.

Caution: Hearth extensions thicker than 1" will interfere with the window frame.

Fig. # 48

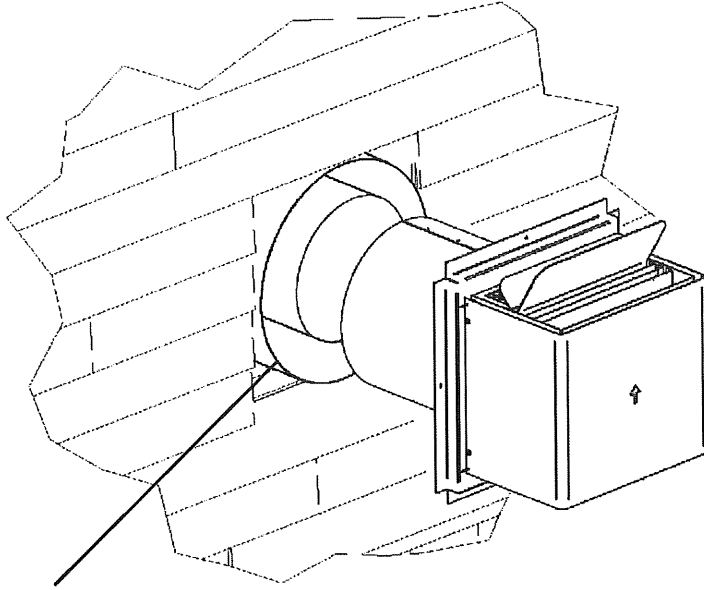

**WALL THIMBLE AND VENT
MUST NOT PROTRUDE
BEYOND SIDING**

Wall thimble:

Where a vent pipe passes through a combustibile wall, a wall thimble/shield must be used to retain insulation and maintain proper clearances. The wall thimble may be cut to length for various wall thicknesses up to 12" thick.

Measure the wall thickness including the siding. Trim the shield to match the wall thickness. Position the wall thimble from inside through the 14-1/2" opening. Properly adjusted, the thimble should be flush with the outer wall surface.

Fig. # 49

Vent System Components	Town & Country
12" Pipe Length	TCVT.811X12
18" Pipe Length	TCVT.811X18
24" Pipe Length	TCVT.811X24
48" Pipe Length	TCVT.811X48
18" Adjustable Pipe Length.....	TCVT.811X12ADJ
45° Elbow	TCVT.811XLB45
90° Elbow	TCVT.811XLB90
Wall/Offset Support	TCVT.811XOS
Wall Termination Kit	TCVT.WTA
Roof Termination Kit	TCVT.RTA
Wall Shield/Ceiling Firestop	TCVT.THIMA
Roof Flashing, Adjustable	TCVT.811FLADJ
Roof Flashing, Flat	TCVT.811FLFLT
Roof Flashing, Steep	TCVT.811FLSTP
	or any flashing that fits 11" pipe

Fig. # 50

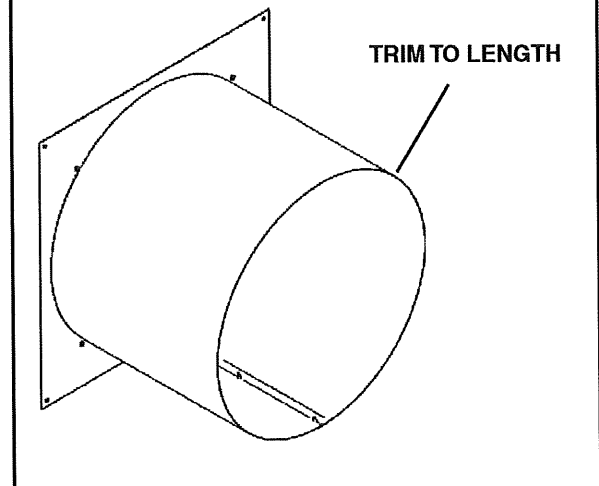

Vent pipe:

Install vent pipe through the wall thimble and attach to flue outlet collar on top of the fireplace. Secure all joints with screws and seal with approved "High Temp." self-adhesive aluminum tape provided.

Adjust the fireplace position so that the vent pipe does not protrude beyond the outer wall. The vent connector on the termination will accommodate walls up to 12" thick.

Wall vent terminal:

- 1) Engage the 8" vent collar with the vent pipe and slide terminal into place. Attach the terminal to the outside wall. **The vent terminal must not be recessed into the exterior wall or siding.**
- 2) Caulk in place to prevent any moisture entering the building.

NOTE: MINIMUM CLEARANCES TO THE VENT TERMINAL MUST BE MAINTAINED (see Fig. #52).

Fig. # 51

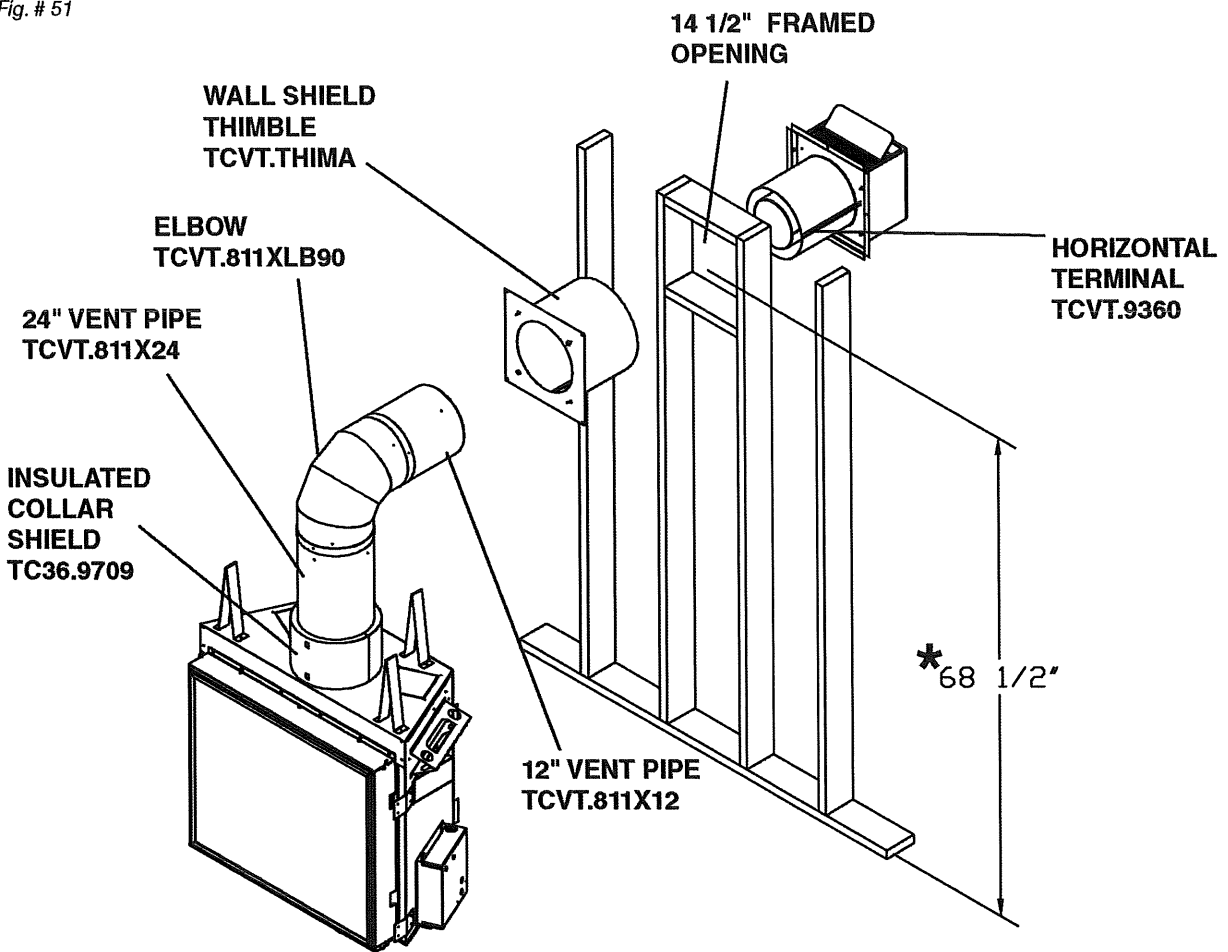

* Minimum height from the floor to center of the opening with a maximum horizontal run of 18" using TC Vent. The height will need to be increased with a longer horizontal run.

WALL TERMINATION VENTING CHART

Fig. # 52

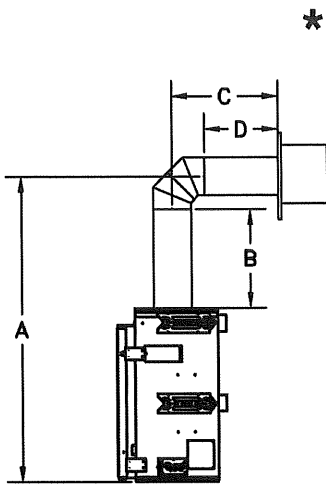

**

A Minimum rise	B Pipe length	C Maximum run	D Pipe length Maximum
68 1/2"	1-24"	20 1/2"	1-12"
72 3/4"	1-12" 1-18"	75 3/4"	1-48" 1-12"
78 3/4"	1-24" 1-12"	11' 2"	2-48" 1-24"
84 3/4"	1-24" 1-18"	15' 10 1/2"	3-48" 1-24" 1-12"
92 1/2"	1-48"	20' 10 1/2"	5-48"

For other rise/run combinations see chart below

** All dimensions are approximate. Both rise and run may vary with different combinations of pipe.

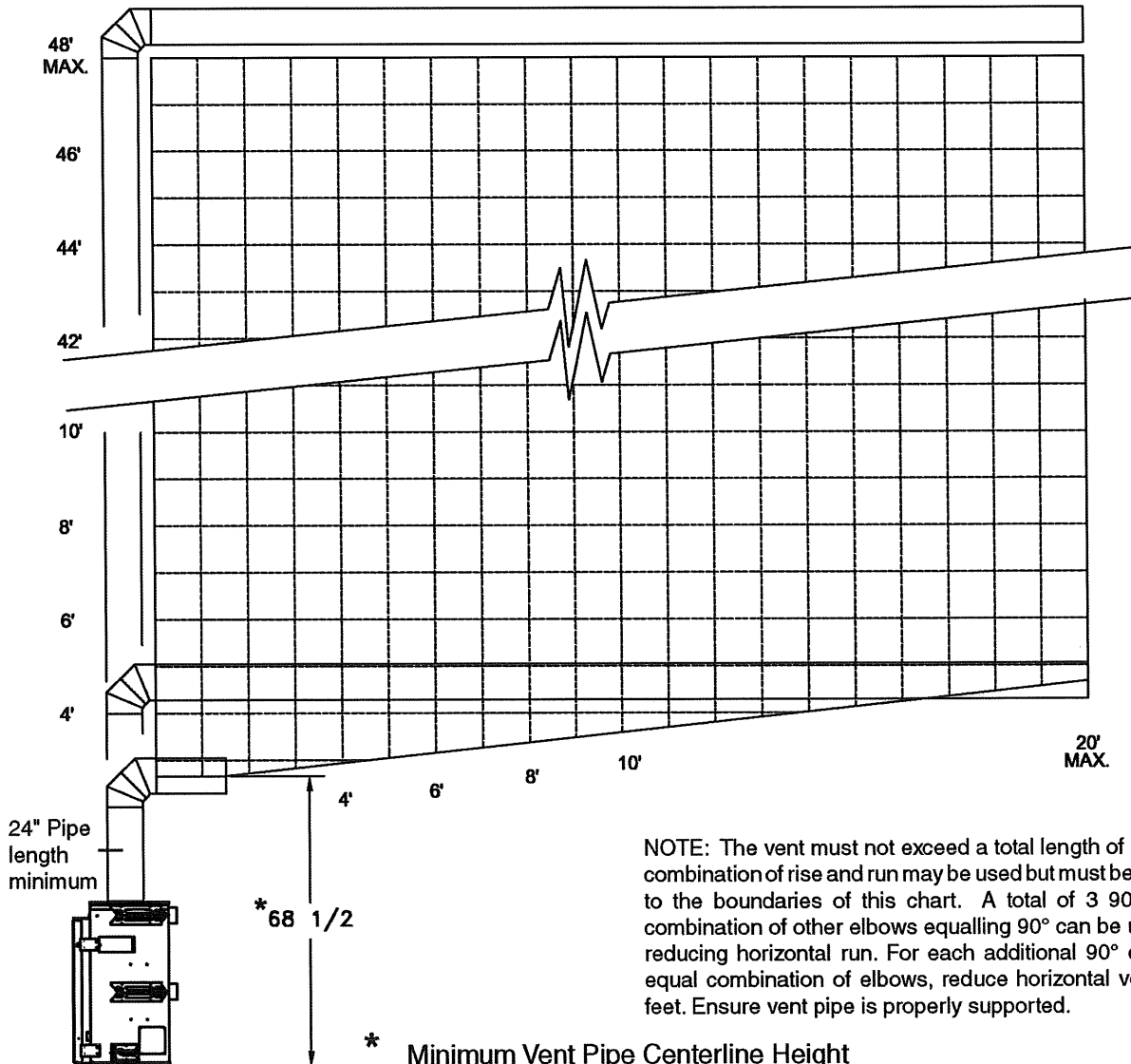

NOTE: The vent must not exceed a total length of 68 feet. Any combination of rise and run may be used but must be constrained to the boundaries of this chart. A total of 3 90° elbows or combination of other elbows equalling 90° can be used without reducing horizontal run. For each additional 90° elbow, or an equal combination of elbows, reduce horizontal vent run by 2 feet. Ensure vent pipe is properly supported.

ROOF TERMINATION VENTING CHART

Fig. # 53

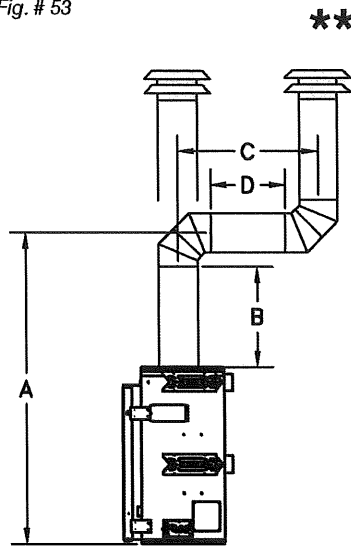

**

A Minimum rise	B Pipe length	C Maximum run	D Pipe length Maximum
68 1/2"	1-24"	29"	1-12"
72 3/4"	1-12" 1-18"	75 1/4"	1-48" 1-12"
78 3/4"	1-24" 1-12"	11' 1 1/2"	2-48" 1-24"
84 3/4"	1-24" 1-18"	15' 10"	3-48" 1-24" 1-12"
92 1/2"	1-48"	20' 10"	5-48"

For other rise/run combinations see chart below

** All dimensions are approximate. Both rise and run may vary with different combinations of pipe.

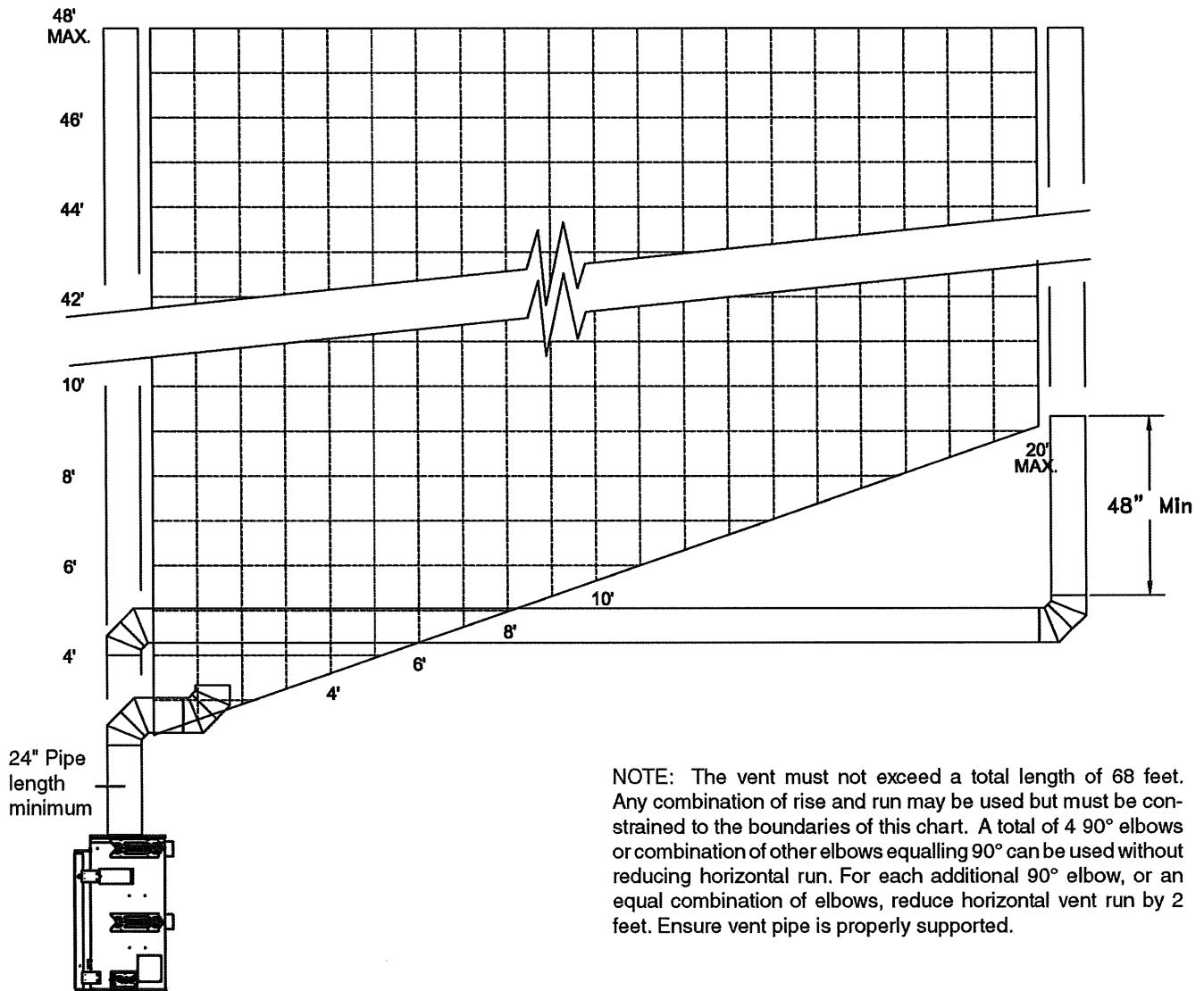

ROOF TERMINATION VENTING

Ceiling opening:

- 1) Determine the exact position of the fireplace so that the vent pipe is centered (if possible) between two building framing members. Lay out the vent system path, minimizing the number of elbows and length of vent. Consult your local building codes prior to proceeding.
- 2) Cut and frame a 14 1/2" opening in the floor, ceiling and roof where the vent system will pass. Size of the opening in the roof may need to be increased as the pitch of the roof increases. Avoid cutting rafters.

Ceiling firestop:

Where a vent pipe passes through a floor or ceiling, a ceiling firestop must be used to retain insulation and maintain proper clearances.

From below, push the ceiling firestop through the opening and secure in place. If the firestop is used to penetrate a floor, the outer shield may be trimmed in length. If the firestop penetrates into an attic, leave the shield full length to keep insulation away from the vent pipe. Additionally, after the vent pipe is in place, install a storm collar on top of the shield. This will prevent loose insulation from falling into the area between the vent pipe and the shield.

Fig. # 55

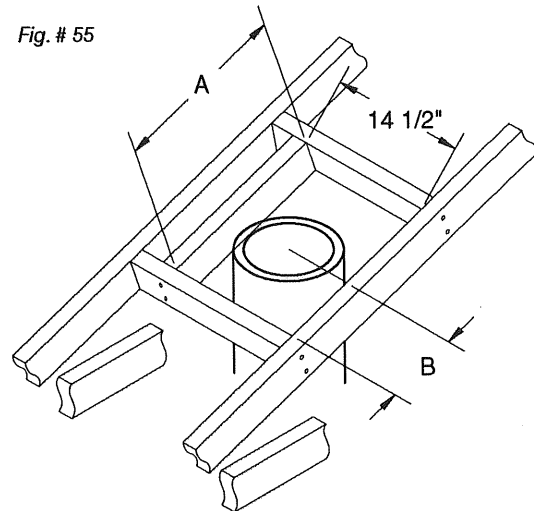

Size of the opening will have to increase with the pitch of the roof to ensure a 1 3/4 inch air space clearance between vent pipe and combustibles.

Roof Pitch	A	B
0/12	14 1/2"	7 1/4"
4/12	16 1/2"	8 3/4"
6/12	18"	10"
8/12	19 3/4"	11"
12/12	24"	13 3/4"

Fig. # 54

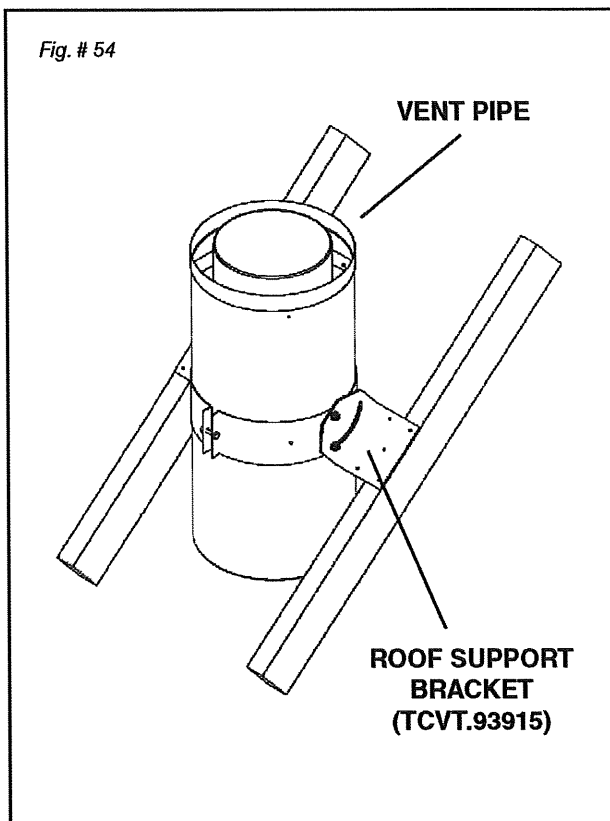

Vent pipe:

- 1) Install the first section of vent pipe into the collar on top of the fireplace. Secure in place with screws and seal with approved "High Temp." self-adhesive aluminum tape provided.
- 2) Continue adding vent pipe lengths up and through the firestop(s) and through the roof. The vent pipe must extend at least 24" above the roof.

Seal the vent pipe as per "Vent Pipe Sealant" section.

Roof support bracket:

Slip the roof support bracket down over the vent pipe. Rotate the 90° brackets to accommodate roof pitch. Attach the brackets to the roof joists with nails or building screws. Tighten the band around the vent pipe and secure in place with screws.

Roof vent terminal:

- 1) Place the roof flashing over top of the vent pipe and nail securely to the roof using roofing nails, top and sides UNDER shingles, lower end OVER shingles to provide a watershed. Make weather tight by sealing with a roofing compound (see Fig. #56).
- 2) Place the storm collar down over the vent pipe until it is level. Tighten storm collar for a snug fit. Apply a thick horizontal ring of mastic around the pipe at top of the storm collar (see Fig. #56).
- 3) Lower the roof vent terminal cap over the vent pipe and secure in place with screws provided (see Fig. #56). Seal screw heads and joint with caulking to prevent any moisture entering the venting system.

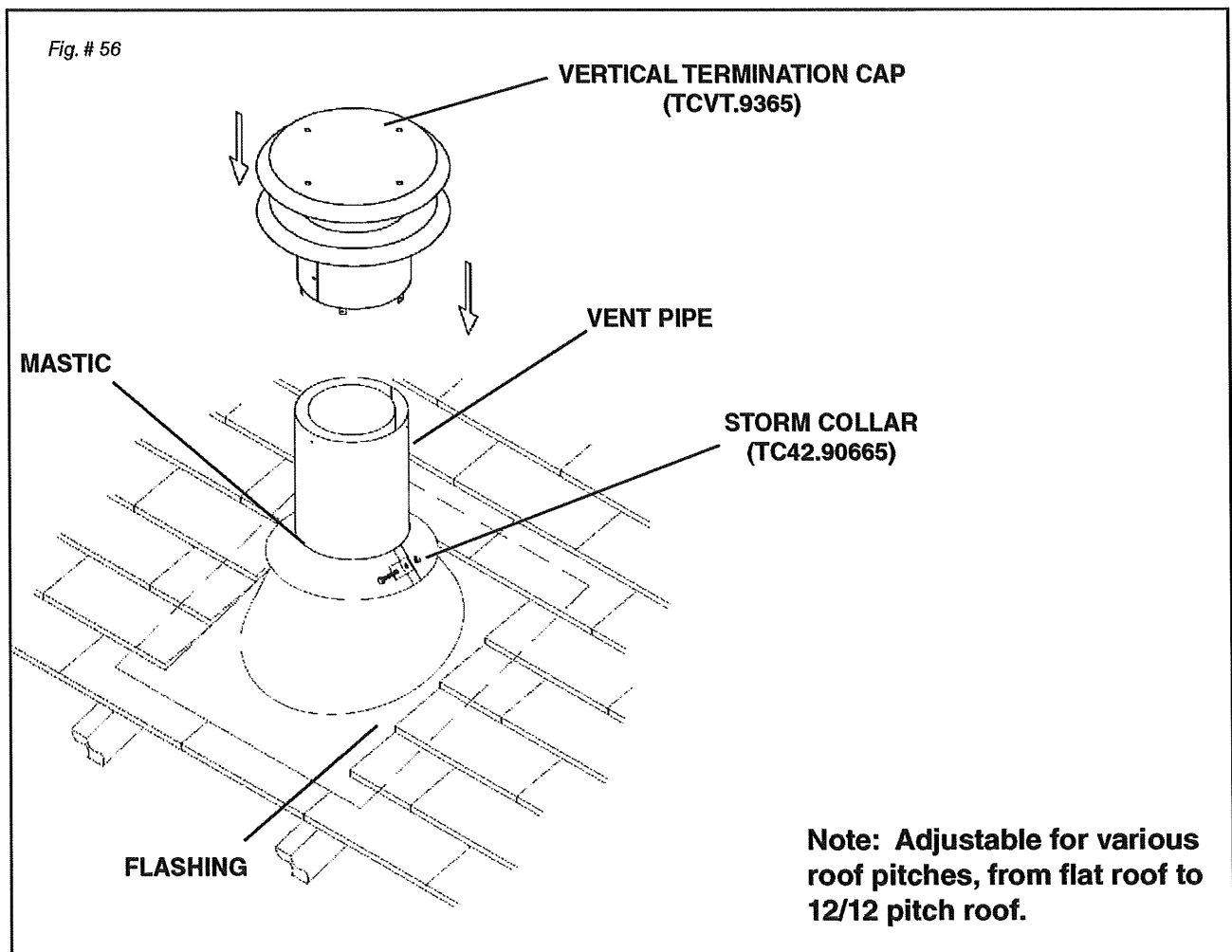

VENT TERMINAL CLEARANCE

Minimum clearances to the vent terminal must be maintained as shown in Fig. #57 and Fig. #58. Measure clearances to the nearest edge of termination hood.

NOTE: Vent terminal must not be recessed into a wall or siding.

NOTE: LOCAL CODES OR REGULATIONS MAY REQUIRE DIFFERENT CLEARANCES.

Fig. # 57

VENT TERMINAL MINIMUM CLEARANCES TO ADJACENT STRUCTURES

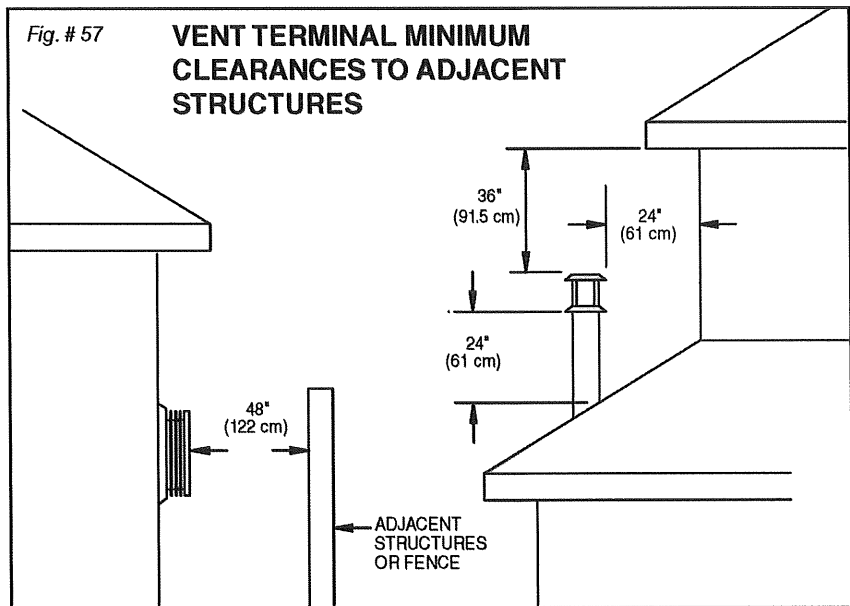
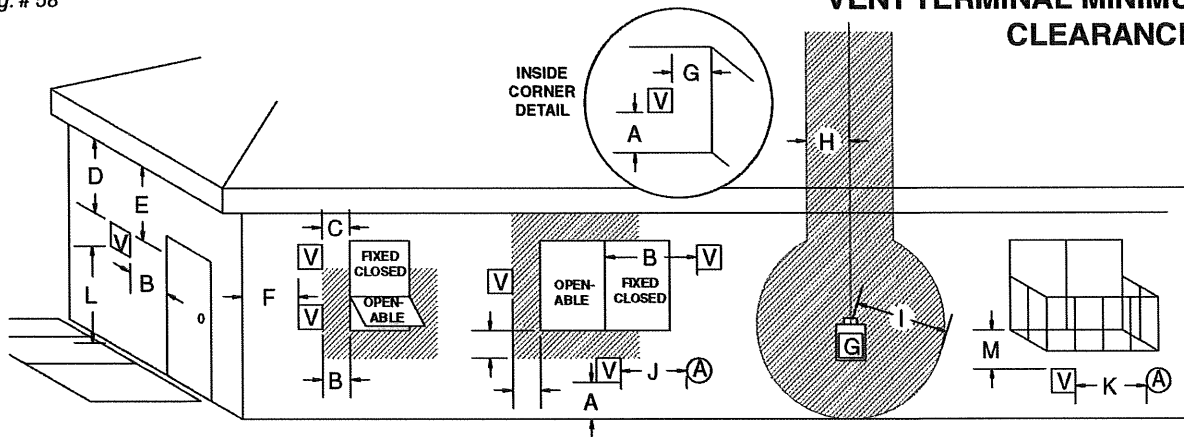

Fig. # 58

VENT TERMINAL MINIMUM CLEARANCES



V VENT TERMINAL

A AIR SUPPLY INLET

■ AREA WHERE TERMINAL IS NOT PERMITTED

G GAS METER

- A= clearances above grade, veranda, porch, deck, or balcony [* 12 inches (30 cm) minimum]
- B= clearance to window or door that may be opened [* 12 inches (30 cm) minimum]
- C= clearance to permanently closed window [minimum 12 inches (30 cm) recommended to prevent condensation on window]
- D= vertical clearance to ventilated soffit located above the terminal within a horizontal distance of 2 feet (60 cm) from the edge of the terminal [30 inches (76 cm) minimum]
- E= clearance to unventilated soffit [30 inches (76 cm) minimum]
- F= clearance to outside corner [6 inches (15 cm) minimum]
- G= clearance to inside corner [6 inches (15 cm) minimum]

- H= * not to be installed above a meter/regulator assembly within 3 feet (90 cm) horizontally from the center-line of the regulator
- I= clearance to service regulator vent outlet [* 6 feet (1.8 m) minimum]
- J= clearance to non mechanical air supply inlet to building or the combustion air inlet to any other appliance [* 12 inches (30 cm) minimum]
- K= clearance to a mechanical air supply inlet [* 6 feet (1.8 m) minimum]
- L= ^ clearance above paved side-walk or a paved driveway located on public property [* 7 feet (2.1 m) minimum]
- M= clearance under veranda, porch, deck, or balcony [30 inches (76 cm) minimum**]

^ a vent shall not terminate directly above a side-walk or paved driveway which is located between two single family dwellings and serves both dwellings*

** only permitted if veranda, porch, deck, or balcony is fully open on a minimum of 2 sides beneath the floor*

* as specified in CGA B149 Installation Codes, Note: local Codes or Regulation may require different clearances

* for U.S.A. Installations follow the current National Fuel Gas Code, ANSI Z223.1

VENT PIPE SEALANT

Fig. #59

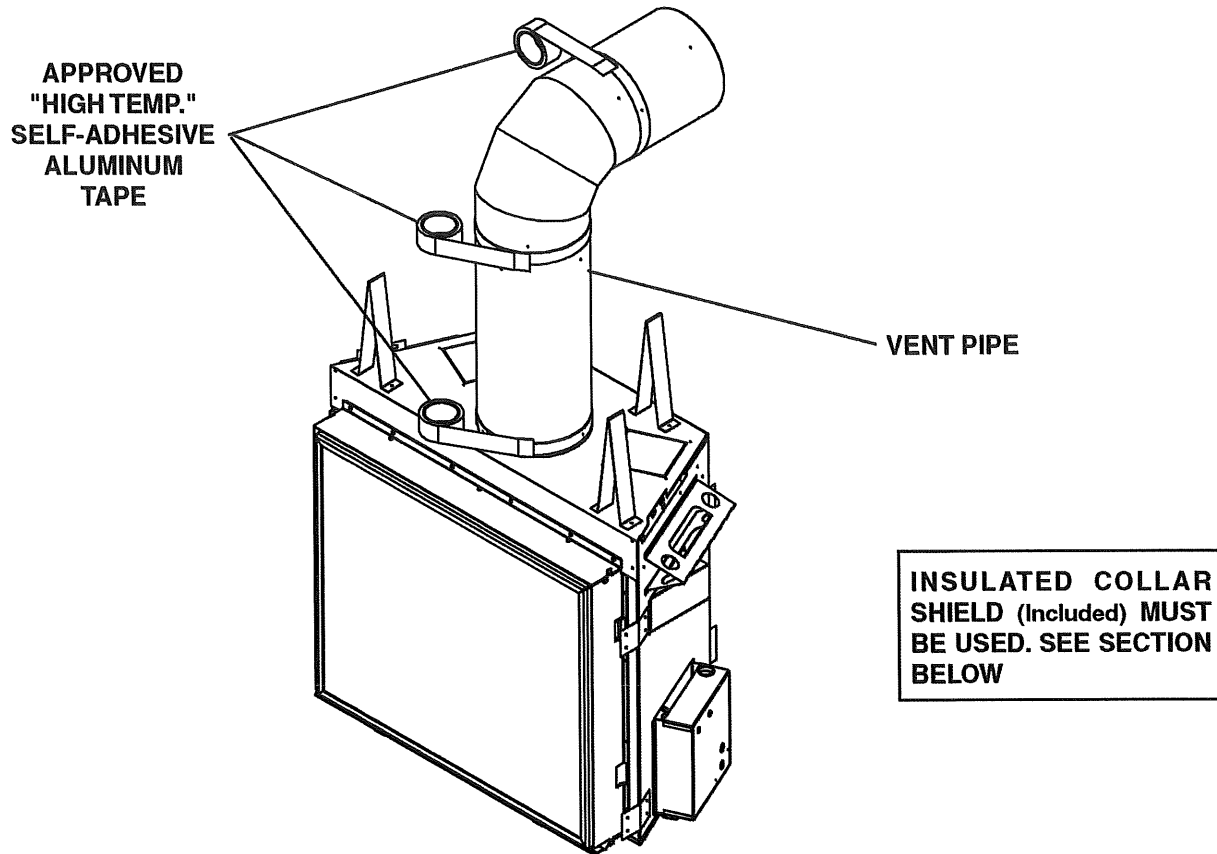

VENT PIPE SEALANT

All outer joints of the vent pipe must be sealed with the approved "High Temp." self-adhesive aluminum tape provided. Wrap the tape completely around the joint and press firmly in place.

INSULATED COLLAR SHIELD

(Included Pt# TC36.9709)

After sealing the vent pipe an insulating blanket and cover **must be installed** around the vent pipe, flush with the top of the unit and secured by fitting tabs through slots and bending over tabs 180° as shown in Fig. #60. The parts required are included. *NOTE: bending tabs to 90° away from arc bend prior to installation eases the process.

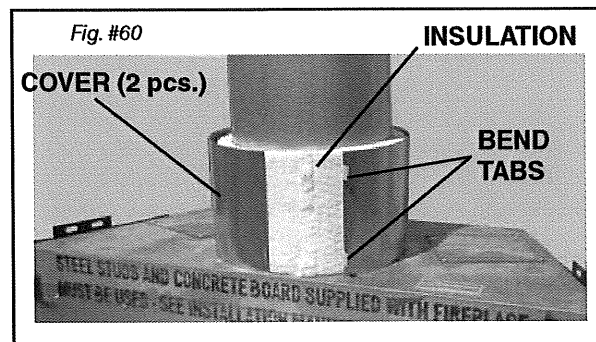

VENT RESTRICTOR ADJUSTMENT

The vent restrictor is located on the underside of the firebox top. The unit leaves the factory with the vent restrictor wide open. The restrictor is built into the appliance for secondary air flow adjustment. Adjustment enables tuning the airflow for optimum flame appearance and performance for a wide variety of vent configurations.

Setting:

- determine the vent height
- determine the vent horizontal length
- from the chart determine the restrictor position

Refer to the chart in Fig. #62 for the correct position of restrictor for the vent configuration of your installation. Restrictor positions are based upon lab tests. The ideal position may vary slightly with installation.

Restrictor position is too closed if the flame has the following characteristics:

- Flame is excessively tall and lifting.
- Flame lacks movement.
- Flame soots.

Restrictor position is too open if the flame has the following characteristics:

- Flame height is low.
- Flame has excessive movement.

To adjust the restrictor:

- Loosen the screw holding the restrictor.
- Push the restrictor back to its intended opening.
- Tighten the screw

Fig. # 61

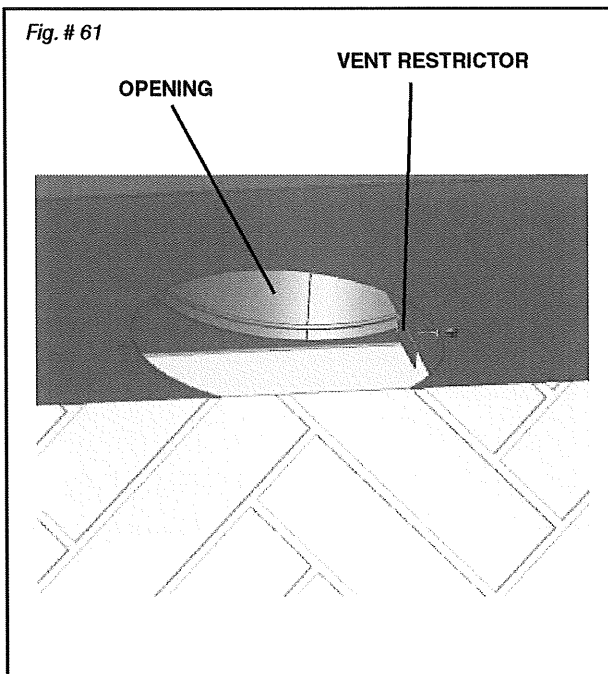
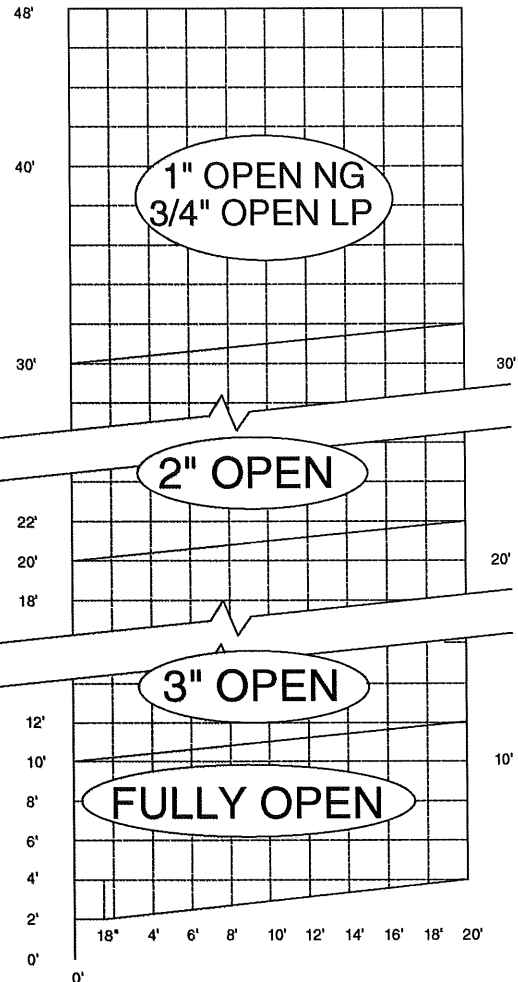

Fig. # 62

WALL AND ROOF TERMINATION RESTRICTOR POSITION



MANUFACTURED (MOBILE) HOME

In some jurisdictions, the Town & Country Fireplace may be installed in Manufactured Homes after the "first sale". **Consult local codes for approval.** The fireplace must be fastened in place.

Install in accordance with the current standard Mobile Homes, CAN/CSA Z240 MH (in CANADA), and the Manufacturer's Home Construction and Safety Standard, Title 24 CFR, Part 3280 or the current Standard for Fire Safety Criteria for Manufactured Home Installations, Sites and Communities ANSI/NFPA 501A (in the U.S.A.).

GAS SUPPLY

Caution: The gas line should be installed by a qualified service person in accordance with all building codes. This section is intended as a guide for qualified technicians installing this appliance. Consult local and/or national building codes before proceeding.

A gas supply line access hole is located at the bottom right side of the Control Box. Gas valve inlet accepts a 3/8" N.P.T. fitting. Correct gas line diameter must be used to assure proper operation.

The gas control is equipped with a capture screw type pressure test port, therefore it is not necessary to provide an 1/8 inch N.P.T. plugged tapping pressure port for checking gas pressure immediately upstream of the gas supply connection to the appliance.

Correct gas pressure requirement:

	Natural Gas	Propane
Min. Pressure <small>(For purpose of Input adjustment)</small>	5.0" wc	12.5" wc
Max. Pressure	13.9" wc	13.9" wc
Manifold Pressure		
Maximum	3.8" wc	11" wc
Minimum	2.1" wc	5.5" wc

WINDOW FRAME REMOVAL

Warning: Turn off the fireplace, and allow ample time for the unit to cool before proceeding.

Caution: The ceramic glass is very fragile, and should be handled with care.

The window frame is held in place by two spring-loaded latches and are operated by a removable handle. The handle is located in the Control Box.

- 1) Insert the latch handle onto the catch located 6" down from the top corners. Rotate up to disengage each of the two catches.
- 2) Tilt the top of the window frame out to clear the top edge of the unit. Grasp the sides of the frame and lift up and out to disengage from its bottom track.
- 3) Place the window frame in a safe place to avoid damage.

Reassemble in reverse order.

Fig # 63



Fig # 64



FIREBOX PANELS INSTALLATION

For porcelain panel kit (TCPN.757031) installation see instructions provided with panel kit.

A Firebox Panel Set has to be installed for safe operation. Do not use the fireplace without panels. Unpack and inspect all panels. The panels need to be installed before the logs are in place.

Caution: The Brick Panels are very fragile, and should be handled with care.

- 1) Remove the Side Panel Retainers located on the underside of the upper firebox heatshield. The retainers are each held in place by one screw.
- 2) Install the Lower Rear Panel.
- 3) Install the Right Side Panel by inserting the bottom of the panel in first and then angling it up into position. It may be necessary to push the upper firebox shield up to allow panel to move freely into place.
- 4) Install the Left Side Panel by inserting the bottom of the panel in first and then angling it up into position.

The lower rear panel is held tight against the side panels by two "V" brackets located on the firebox rear wall. Although the brackets are adjusted at the factory for the best fit, some adjustment may be necessary. Adjust the angle of the bracket by hand to ensure a snug fit.

Fig. #66

ADJUSTABLE "V" BRACKET



REAR LOWER PANEL

- 5) Install the Rear Upper Panel.
- 6) Re-install the Side Panel Retainers.
- 8) Install the Left and Right Front Panels.

Fig. # 65

BEIGE HERRINGBONE PANEL SET FOR TC 36 SHOWN

LEFT SIDE
PANEL

REAR UPPER
PANEL

REAR LOWER
PANEL

RIGHT SIDE
PANEL

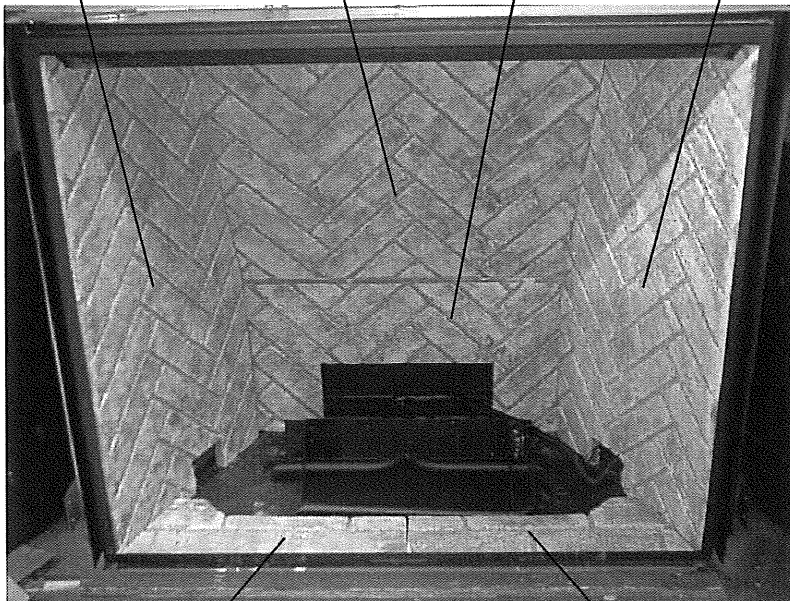

LEFT FRONT
PANEL

RIGHT FRONT
PANEL

TC36 PANELS

Beige Full Herringbone
TCPN.757

Heritage Red Brick
TCPN.7571

Tuscan
TCPN.74741

Black Porcelain
TCPN.757031

TC36 ARCH PANELS

Beige Full Herringbone
TCPN.7566

Heritage Red Brick
TCPN.75704

Tuscan
TCPN.748

Black Porcelain
TCPN.75702W

LIGHTING INSTRUCTIONS

FOR YOUR SAFETY READ BEFORE LIGHTING

WARNING: If you do not follow these instructions exactly, a fire or explosion may result causing property damage, personal injury or loss of life.

- A. This appliance is equipped with an ignition device which automatically lights the pilot. Do not try to light the pilot by hand.
B. BEFORE LIGHTING smell all around the appliance area for gas. Be sure to smell next to the floor because some gas is heavier than air and will settle on the floor.
WHAT TO DO IF YOU SMELL GAS:
- Do not try to light any appliance.

- Do not touch any electric switch; do not use any phone in your building.
- Immediately call your gas supplier from a neighbour's phone. Follow the gas supplier's instructions.
- If you cannot reach your gas supplier, call the fire department.
C. Use only your hand to push in or turn the gas control knob. Never use tools. If the knob will not push in or turn by hand, don't try to repair it, call a qualified service technician. Force or attempted repair may result in a fire or explosion.
D. Do not use this appliance if any part has been under water. Immediately call a qualified service technician to inspect the appliance & to replace any part of the control system & any gas control which has been under water.

LIGHTING INSTRUCTIONS

1. STOP! Read the safety information above on this label.
2. Set wall switch/ hand held remote to lowest setting.
3. This appliance is equipped with an ignition device which automatically lights the pilot. Do not try to light the pilot by hand.
4. Push the "On/ Off" switch to the fireplace Off.
5. Allow sufficient length of time (minimum 5 minutes) for any gas in the combustion chamber to escape. If you still smell gas, STOP! Follow "B" in the safety information above on this label. If you don't smell gas, go to the next step.
6. Push the "On/ Off" switch to turn the fireplace on.
- If the burner does not light, repeat steps 4 through 6.
- If the burner will not light or stay lit after several tries, push the "On/ Off" switch to the fireplace off and call your service technician or gas supplier.
Note: Sufficient time must be allowed for air to escape from lines if the unit is being lit for the first time.
7. Set fireplace to desired setting by using either the wall switch or hand held remote.

TO TURN OFF GAS TO APPLIANCE

1. Set wall switch / hand held remote to lowest setting.
2. Push the "on/ off" switch to the "Off" position.
3. Turn off all electric power to the appliance and remove backup batteries if service is to be performed or for extended shutdown.

Due to high surface temperatures, keep children, clothing and furniture away. Keep burner and control compartment clean. See installation and operating instructions accompanying the appliance.
A cause de la temperature elevee des parois, tenir eloignes les enfants, les vetements et les meubles. Maintenir propres le bruleur et le compartiment de commande. Voir les instructions relatives a l'installation et au fonctionnement qui accompagnent l'appareil.

CAUTION: Hot while in operation. Do not touch. Severe burns may result. Keep children, clothing, furniture, gasoline and other liquids having flammable vapours away. Keep burner and control compartment clean. See installation and operating instructions accompanying the appliance.

ATTENTION: L'appareil est chaud lorsqu'il fonctionne. Ne pas toucher l'appareil. Risque de brûlures graves. Surveiller les enfants. Garder les vêtements, le meubles, l'essence ou autres liquides produisant des vapeurs inflammables loin de l'appareil. S'assurer que le brûleur et le compartiment des commandes sont propres. Voir les instructions d'installation et d'utilisation qui accompagnent l'appareil.

310106

5051.173

5-TC30

FIRST FIRE

When lit for the first time, the fireplace will emit a slight odour for a couple of hours. This is due to the curing of paints, sealants and lubricants used in the manufacturing process. This condition is temporary. Open doors and windows to ventilate area. Smoke and fumes caused by the curing process may cause discomfort to some individuals.

It is normal for fireplaces fabricated of steel to give off some expansion and/or contraction noises during the start up or cool down cycle. Similar noises are found with your furnace heat exchanger or cook stove oven.

APPENDIX A

MAINTENANCE

Caution: Turn off gas and electrical power supply (if applicable) and allow ample time for unit to cool before servicing appliance. It is recommended that the fireplace and its venting should be inspected at least once a year by a qualified service person.

Glass Panel:

Warning: Do not operate fireplace with glass panel removed, cracked or broken. Replacement of the glass panel should be done by a licensed or qualified service person.

Do not strike or otherwise impact the glass in anyway that may cause it to break. If the glass becomes cracked or broken, it must be replaced before using the fireplace. Replacement glass can be obtained from your nearest Town and Country Fireplaces™ dealer. The size required is 36" x 30" x 5mm. Use ceramic glass only. **Do not substitute with any other type.**

To remove broken glass, remove window frame as noted in "Window Frame Removal" section.

Unclip the Glass Retainer Clips located at the top of the Window Frame. Pull the top edge of the glass out of the frame first, then lift it up and out of the bottom edge.

Install the new piece of glass with the gasket into the frame

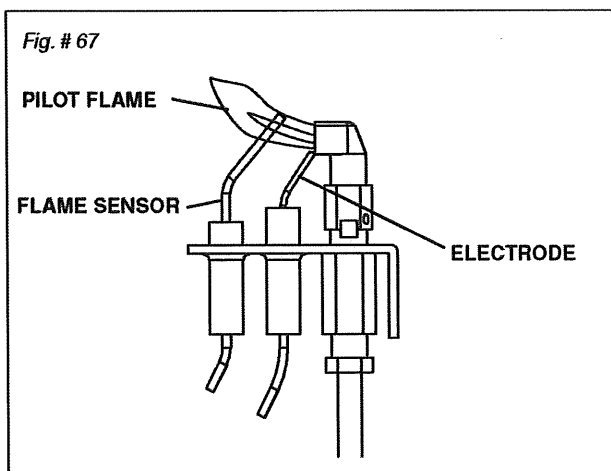

so that the thicker bead of gasket faces the fireplace.

Annual Inspection:

a) Remove glass panel and log set. Inspect logs and burner assembly for soot buildup. If excessive buildup of soot is present, have a qualified service person inspect and adjust unit for proper combustion. Clean logs and burner with a brush or vacuum cleaner, paying close attention to burner ports.

b) Check the pilot system for proper flame size and operation. Clean pilot free of soot, dust or any other deposits. (See Fig. #67)

c) Check that the vent pipe and vent terminal are open and free from blockage or debris. If the venting is disassembled for cleaning, it must be properly assembled and re-sealed. Refer to VENTING section for proper procedure.

d) Check glass panel gasket, replace if necessary. It is important that the glass seal be maintained in good condition.

e) Check and replace batteries as needed.

Note: The appliance area must be kept clear and free from combustible materials, gasoline and other flammable vapours and liquids.

Periodically:

a) Viewing glass may be cleaned as necessary with fireplace glass cleaner.

b) Exterior finish may be cleaned with mild soap and water.

CAUTION:

Do not use abrasive cleaners on glass or any other part of the fireplace.

POWER VENT WIRING DIAGRAM
WIRING DIAGRAM

Optional Power Vent Kit provided by Town & Country

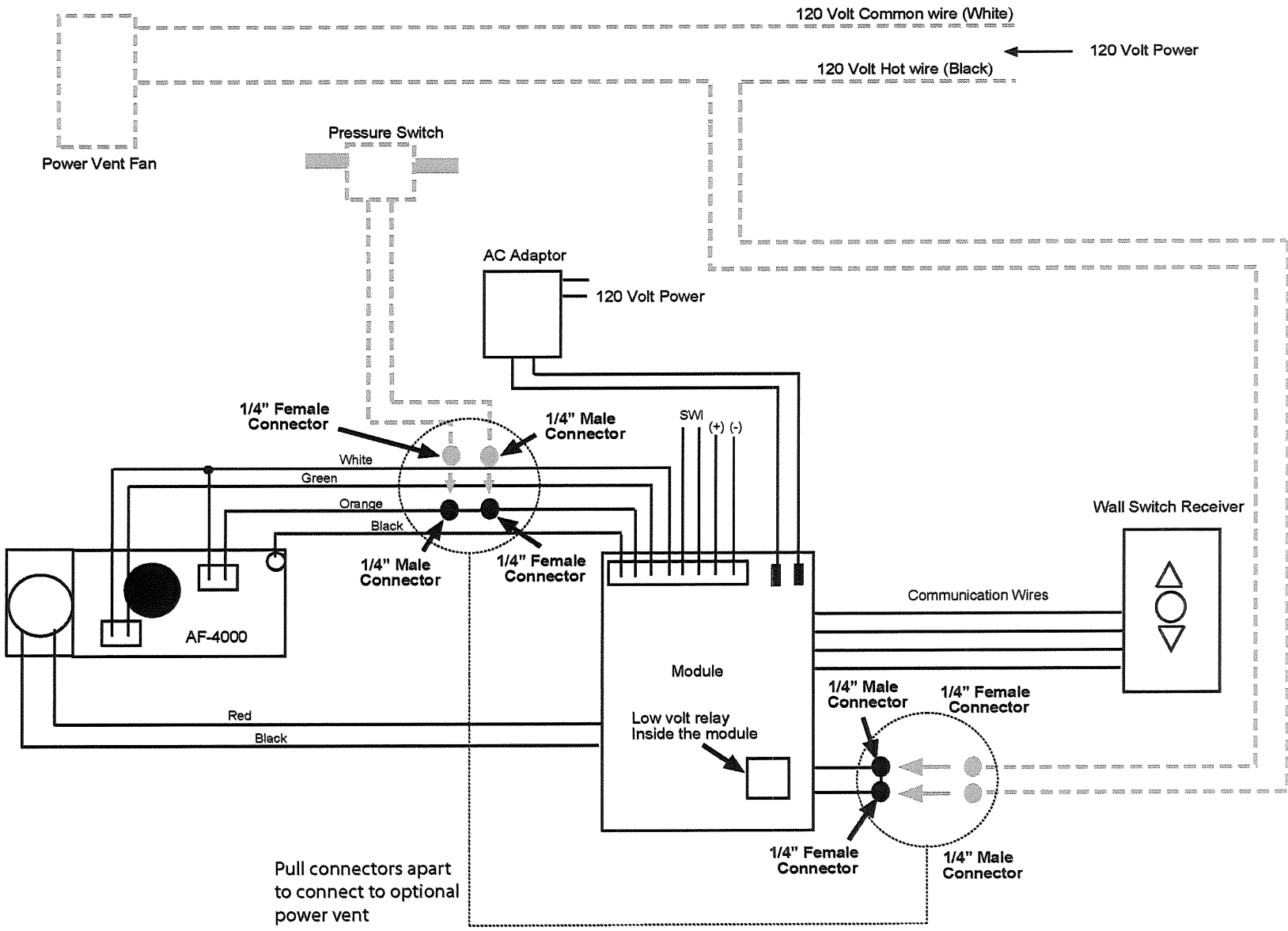

TC36 & TC36 ARCH REPLACEMENT PARTS

(WHEN ORDERING, INCLUDE PART NUMBER WITH DESCRIPTION)

ITEM	DESCRIPTION	PART NO.	ITEM	DESCRIPTION	PART NO.
1	GLASS FRAME	TC36.9120	I	PANEL, UP. BK, HERITAGE RED	5098.7571.1
2	REPLACEMENT GLASS (c/w gasket) GLAS.2087		I 13	PANEL, LEFT SIDE, HERNGBN	5098.7564.B
	GLASS RETAINER, TOP	9050.001	I	PANEL, LEFT SIDE, TUSCAN	5098.7473.B
	GLASS GASKET KIT	2087.1	I	PANEL, LT SD, HERITAGE RED	5098.7571.2B
	FRAME & GLASS ASSEM.	TC36.9120ASSY	I 14	PANEL, LEFT BASE, BRICK	5098.755
3	CONTROL ASSEMBLY	TCCV.9270.A	I	PANEL, LEFT BASE, TUSCAN	5098.7466
4	SPRING LATCH ASSEMBLY	TC42.9024	I	PANEL, LT BASE, HERITAGE RED	5098.7571.5
	REMOVABLE LATCH HANDLE	TC42.9028	I 15	PANEL, LOWER BACK, HERNGBN	5098.7562
5	INSULATED COLLAR SHIELD	TC36.9709	I	PANEL, LOWER BACK, TUSCAN	5098.7471
6	BURNER PLATE	9786	I	PANEL, LW BK, HERITAGE RED	5098.7571.4
	BURNER PLATE INSULATION	9786.5	I 16	PANEL, RIGHT BASE, BRICK	5098.756
7	BRICK PANEL RETAINER	1908.603	I	PANEL, RIGHT BASE, TUSCAN	5098.7467
8	FIREBOX HEAT SHIELD	9704	I	PANEL, RT BASE, HERITAGE RED	5098.7571.6
	SHIELD INSULATION (not shown)	9704.5		PANEL SET, HERRINGBONE	TCPN.757
	SHIELD INSULATION (not shown)	9704.8		PANEL SET, TUSCAN	TCPN.74741
	FIREBOX SHIELD ASSEMBLY	TC36.9704		PANEL SET, HERITAGE RED	TCPN.7571
9	FLUE DAMPER TAB	9104.7	I NOT SOLD SEPARATELY		
10	FLUE DAMPER	9004.501	All parts may be ordered from your nearest Town and Country Fireplaces™ dealer. Contact Town and Country Fireplaces™ for the location of the dealer nearest you.		
I 11	PANEL, RIGHT SIDE, HERNGBN	5098.7565.B			
I	PANEL, RIGHT SIDE, TUSCAN	5098.7474.B			
I	PANEL, RT SD, HERITAGE RED	5098.7571.3B			
I 12	PANEL, UP. BACK, HERRINGBONE	5098.7563			
I	PANEL, UP. BACK, TUSCAN	5098.7472			

Fig. # 69

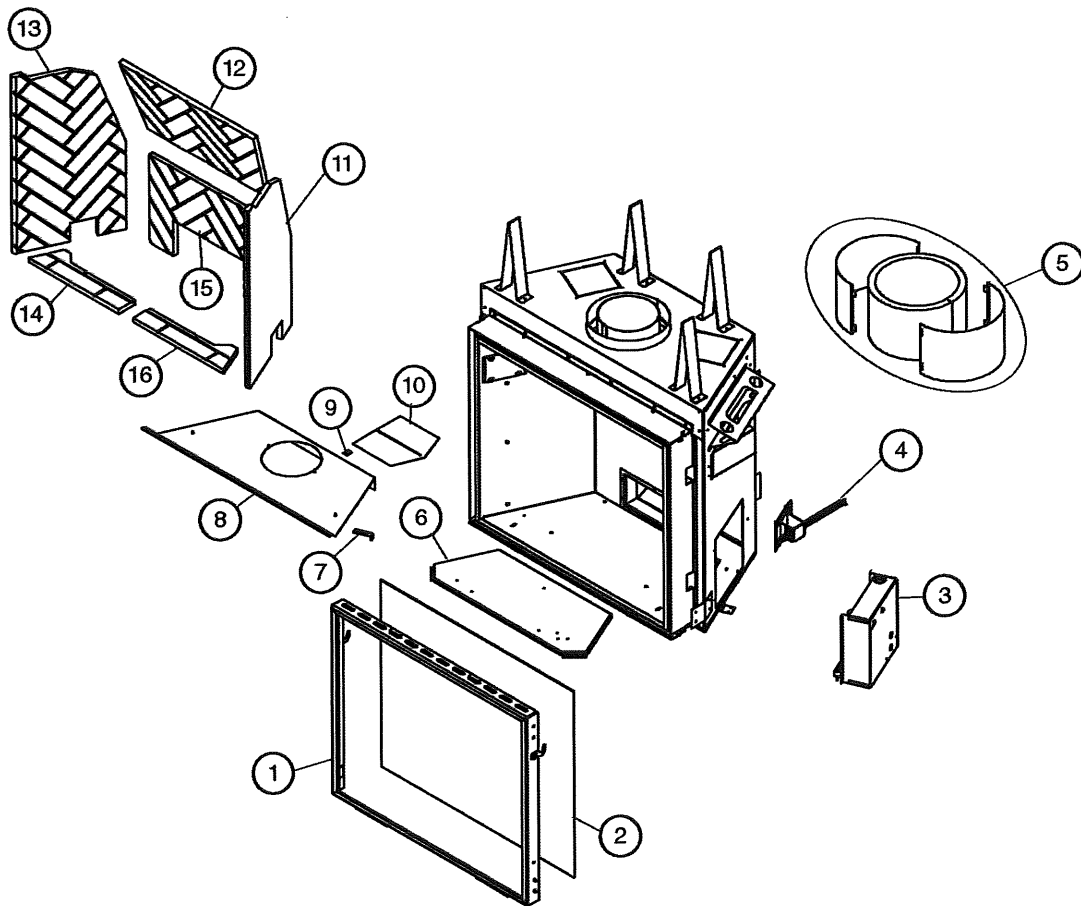

TC36 ARCH SPECIFIC REPLACEMENT PARTS

(WHEN ORDERING, INCLUDE PART NUMBER WITH DESCRIPTION)

ITEM	DESCRIPTION	PART NO.
1	GLASS FRAME	TC36.9520
2	REPLACEMENT GLASS(c/w gasket)	GLAS.2088
	GLASS GASKET KIT	2088.1
8	FIREBOX HEAT SHIELD	9504.01
	SHIELD INSULATION (not shown)	9504.5
	SHIELD INSULATION (not shown)	9504.71
10	FLUE DAMPER	9504.2
11	PANEL, RIGHT SIDE, HRNG	5098.7566.C2
	PANEL, RIGHT SIDE, TUSCAN	5098.748.C2
	PANEL, RT SD, HERITAGE	5098.75704.C2
12	PANEL, UPPER BACK, HRNG	5098.7566.C3
	PANEL, UPPER BACK, TUSCAN	5098.748.C3
	PANEL, UP BACK, HERITAGE	5098.75704.C3
13	PANEL, LEFT SIDE, HRNG	5098.7566.C1
	PANEL, LEFT SIDE, TUSCAN	5098.748.C1
	PANEL, LT SD, HERITAGE	5098.75704.C1
	PANEL SET, HERRINGBONE	TCPN.7566
	PANEL SET, TUSCAN	TCPN.748
	PANEL SET, HERITAGE RED	TCPN.75704

| NOT SOLD SEPARATELY

All parts may be ordered from your nearest Town and Country Fireplaces™ dealer. Contact Town and Country Fireplaces™ for the location of the dealer nearest you.

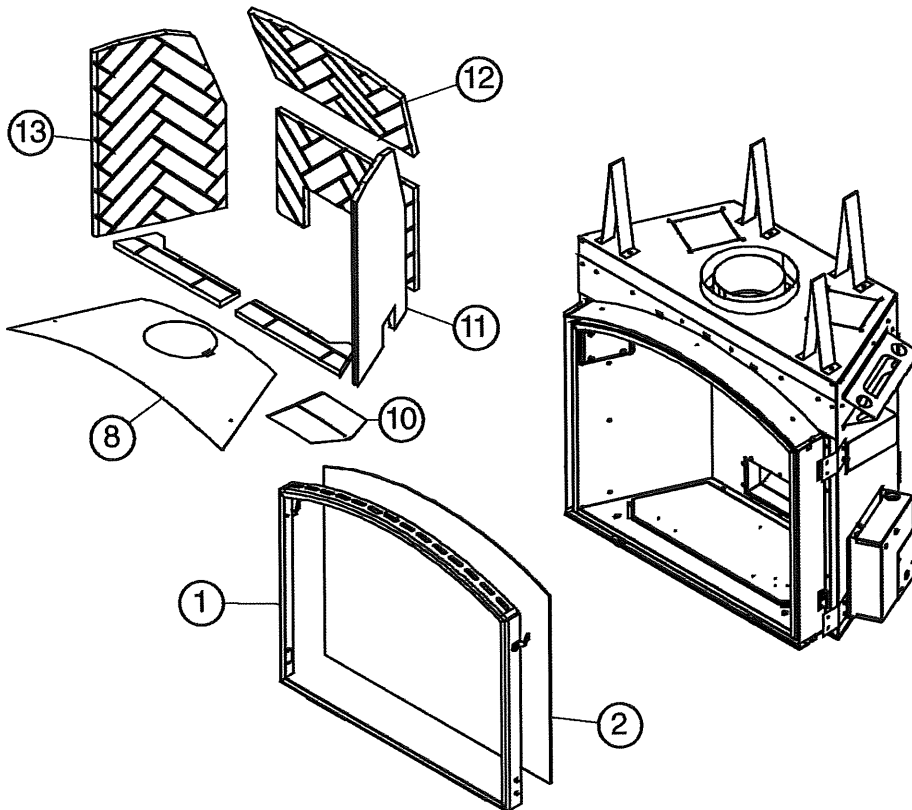

REPLACEMENT PARTS - MAESTRO CONCEALED VALVE
 (WHEN ORDERING, INCLUDE PART NUMBER WITH DESCRIPTION)

ITEM.....	DESCRIPTION.....	PART NO.	ITEM.....	DESCRIPTION.....	PART NO.
1	CONTROL ASSEMBLY	TCCV.9270	116	1/4" BULKHEAD FITTING	5019.101
12	VALVE c/w FITTINGS	TCCV.500501	117	ELEC BULKHEAD FITTING	5005.026
13	WIRING HARNESS	5005.21	18	UTILITY BOX ASSEMBLY	TCCV.5024405
14	1/4" FLEX TUBE	5019.225	119	UTILITY BOX	5024.405
15	1/2" FLEX TUBE	5019.223	120	ELECTRICAL RECEPTACLE	5024.406
16	CONTROL MOUNTING BRACKET	9271	121	COVER PLATE	5024.407
17	IGNITION MODULE	5005.2	22	BATTERY HOLDER	5005.043
18	IGNITION/ SENSOR WIRES	TCCV.50625	23	WALL SWITCH COVER PLATE	5005.042
19	PRESSURE TEST ASSEMBLY	TC30.92145	24	WALL SWITCH	5005.041
110	AC ADAPTOR	5005.03	25	25' COMMUNICATION CABLE	5005.06
11	BULKHEAD ASSEMBLY	TC30.9284	26	WING NUT	5049.3
112	INLET PLATE	9284	27	CONTROL BOX WELDED ASM.	TCCV.9270WLD
113	INLET PLATE GASKET	5068.93147	28	TEST FITTING	5019.104
114	ELEC BULKHEAD GASKET	5068.9285	29	REMOTE HAND SET	5005.05
115	1/2" BULKHEAD FITTING	5019.102			

| NOT SOLD SEPARATELY

Fig. # 70

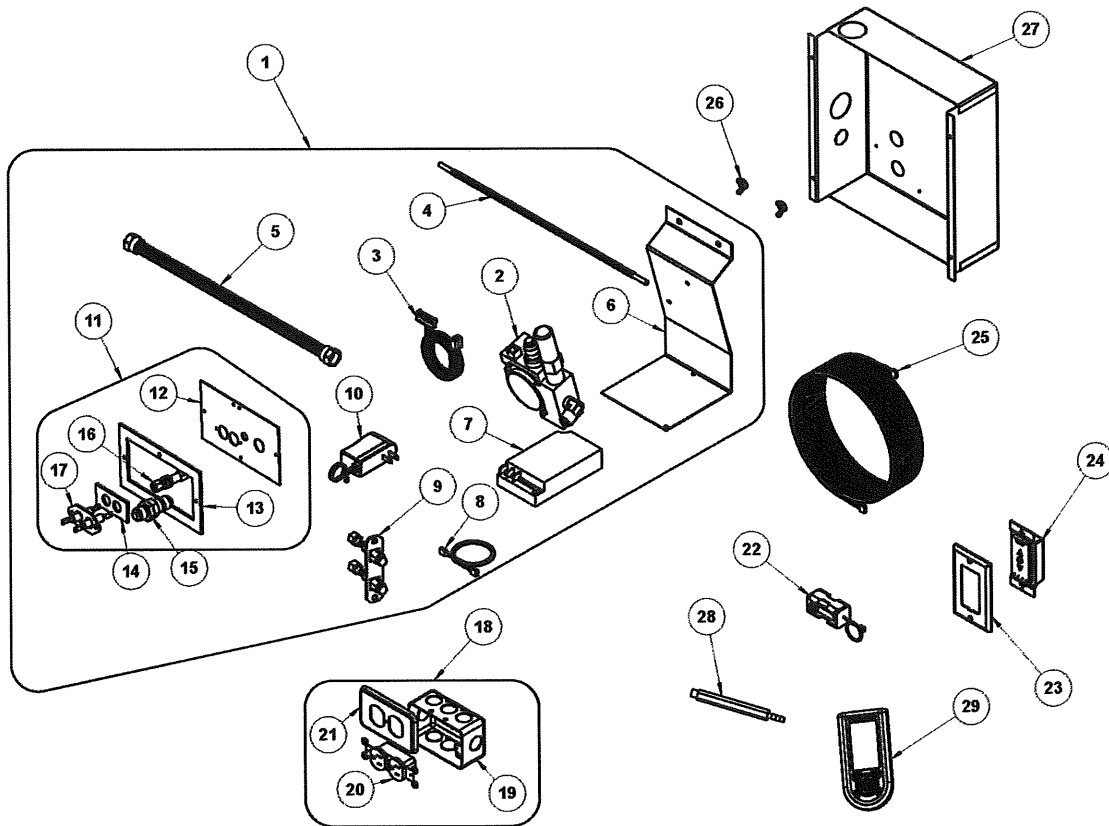

**WALL TERMINATION KIT
TCVT.WTA**

Fig. # 71

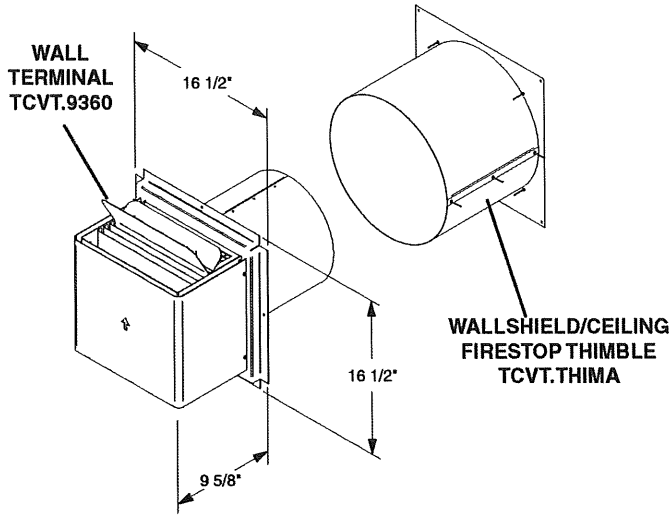

**WALL SHIELD/CEILING FIRESTOP THIMBLE
TCVT.THIMA**

Fig. # 72

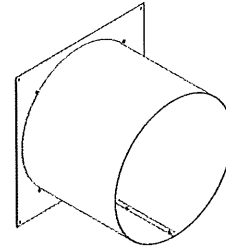

**ROOF TERMINATION KIT
TCVT.RTA**

Fig. # 73

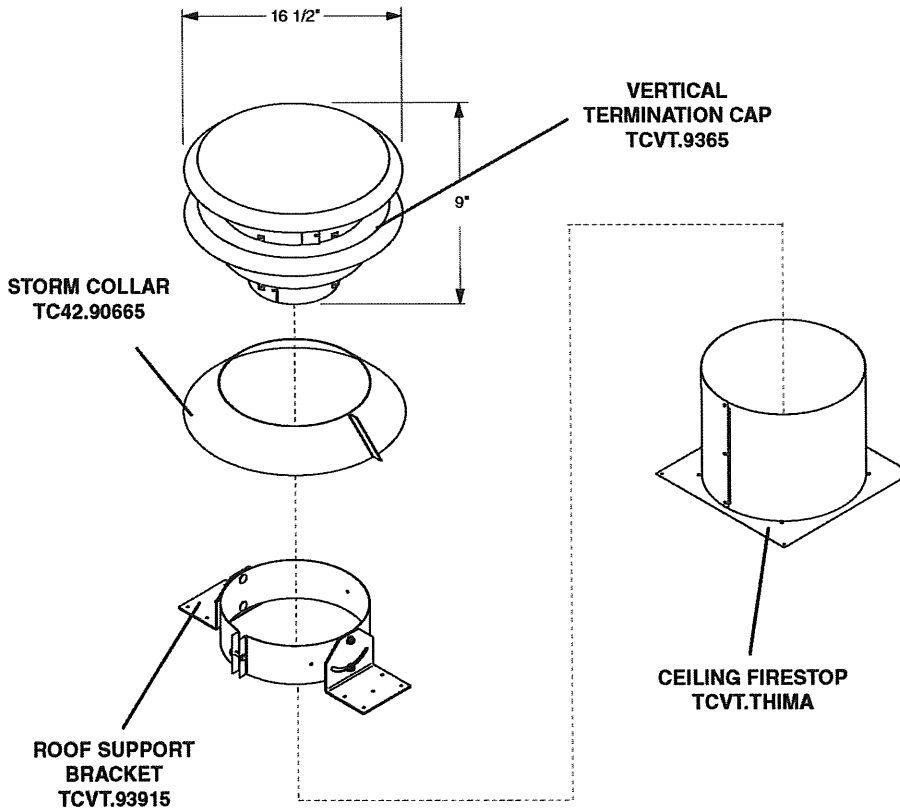

VENT PIPE DIMENSIONS

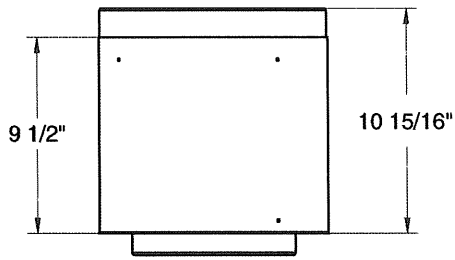

TCVT.811X12ADJ

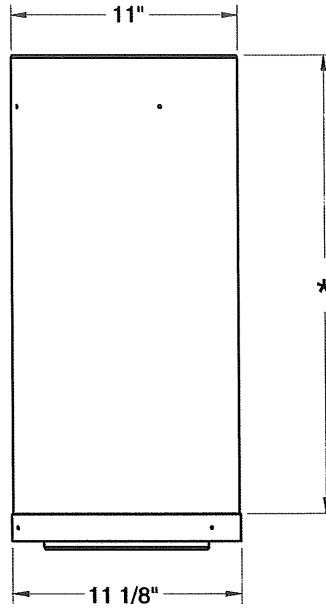

TCVT.811X__

*

12" Pipe	10 1/4"
18" Pipe	16 1/4"
24" Pipe	22 1/4"
48" Pipe	46 1/4"

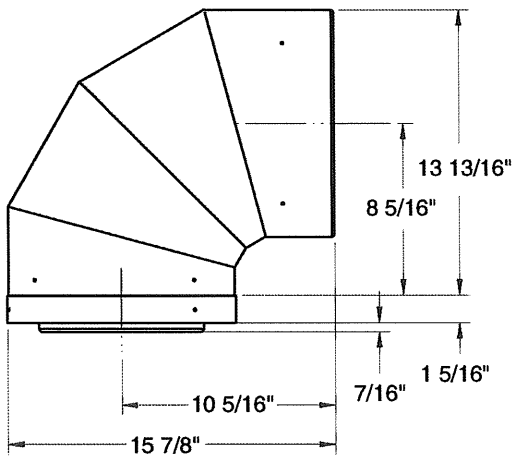

TCVT.811XLB90

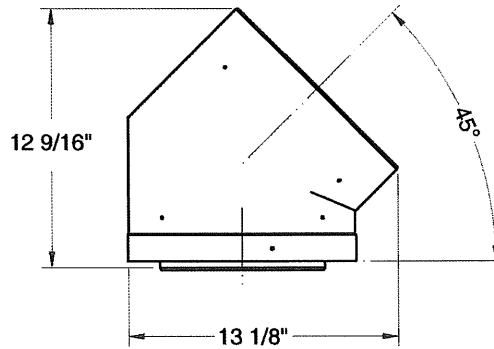

TCVT.811XLB45

Fig. # 75

VENT OFFSET CHART

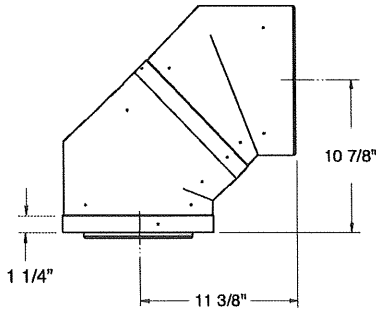

	A	B	C
12" Pipe.....	18 5/8"	18"
18" Pipe.....	22 7/8"	22 3/8"
24" Pipe.....	27 1/8"	26 1/2"
48" Pipe.....	44 1/16"	43 1/2"

Adding an adjustable section to pipe will increase offset by 2 1/8" to 6 3/4"

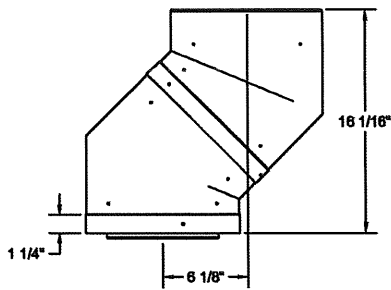
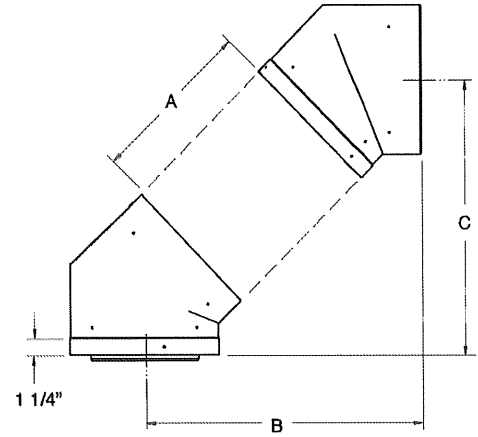

	A	B	C
12" Pipe.....	13 7/16"	23 1/4"
18" Pipe.....	17 9/16"	27 5/8"
24" Pipe.....	21 7/8"	31 3/4"
48" Pipe.....	38 3/4"	48 7/8"

Adding an adjustable section to pipe will increase offset by 2 1/8" to 6 3/4"

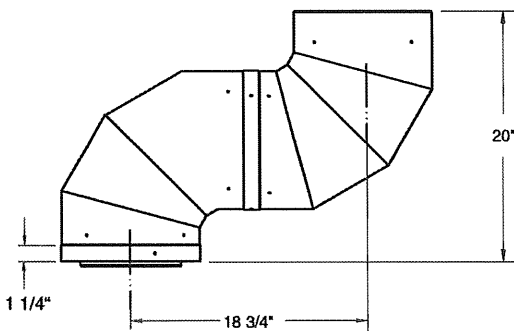
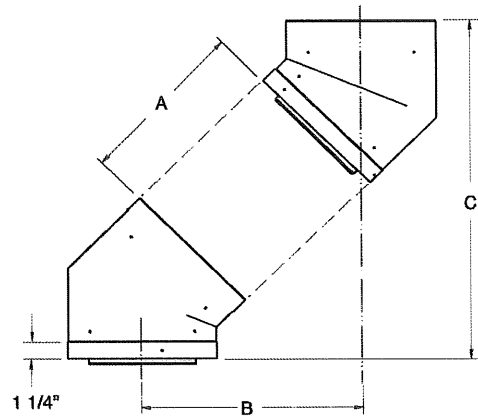

	A	B
12" Pipe.....	29"	
18" Pipe.....	35"	
24" Pipe.....	41"	
48" Pipe.....	65"	

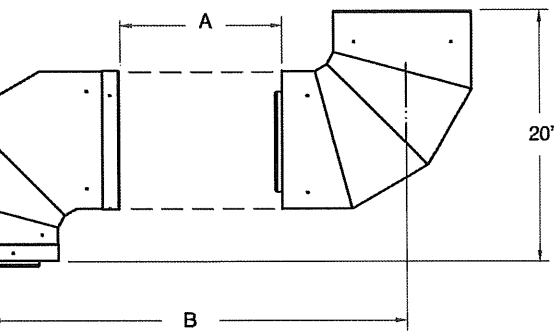

Adding an adjustable section to pipe will increase offset by 3" to 9 1/2"

STEEL STUD FRAMING KIT

TC36.BFRKITA

Each Kit Contains:

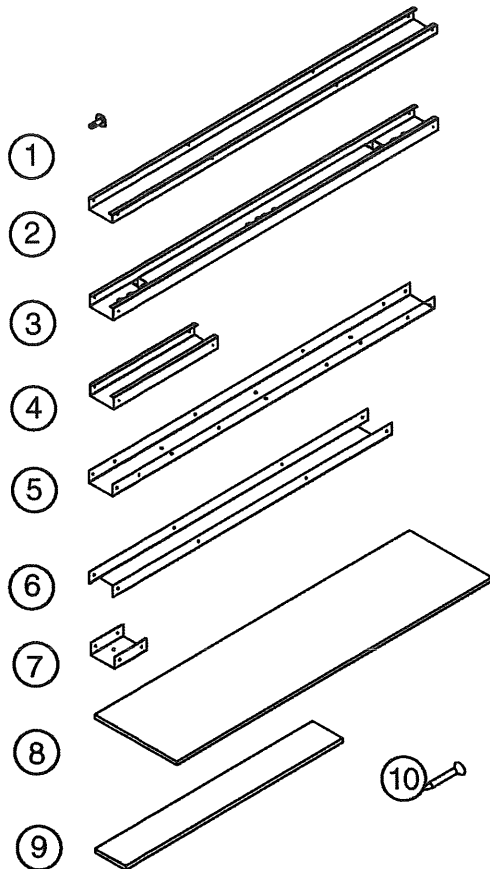

Item	Part #	Description	Qty.
1	5049.9912	SCREW, TEKS #8 x 1/2	Pkg 40
2	9794.2	STUD, SIDES, 48"L	2
3	9794.5	STUD, OUTER SIDES, 48"L	2
4	9093.22	STUD, CENTER, 15 1/2"L	2
5	9193.501	STUD, HEADER, 47 1/2"L	1
6	9393.001	STUD, PLATE, 41 1/4"L	1
7	9194.5	BASE PLATE 6"L	2
8	9798.1	CONCRETE BOARD, TOP 12" x 46 3/4"	1
9	9798	CONCRETE BOARD, SIDE 4 1/2" x 32 1/4"	2
10	5049.993	SCREW, DRYWALL, 1 1/4"	Pkg 30

The Steel Stud Framing Kit is wider than the minimum required in the installation manual. Once fully assembled, the framing kit fits into a 48" wide x 48 1/4" high framed opening.

WARNING!
EDGES ARE SHARP, ALWAYS WEAR GLOVES WHEN WORKING WITH SHEET METAL.

1. Top Frame Assembly

- Lay out side studs (2) and center studs (4) on a large flat surface, see Fig. #76.
- Using the screws provided (1), attach the header stud (5) and the plate stud (6) to the center studs (4).

Fig. #76

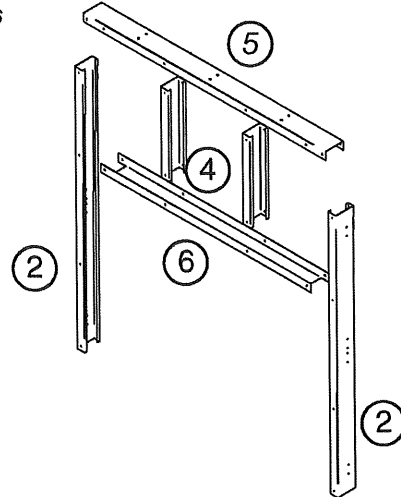

2. Attach Side Studs (Legs)

- Attach the outer side studs (3) to the top of the header stud (5), see Fig. #77.
- Fasten the outer side studs (3) at the bottom using the base plates (7).

3. Attach the Assembled Frame to the Unit

- Align the assembled frame to the unit framing brackets, see Fig. #78. Attach at the fastening points through the access holes in the outer side studs (3).

Fig. #77

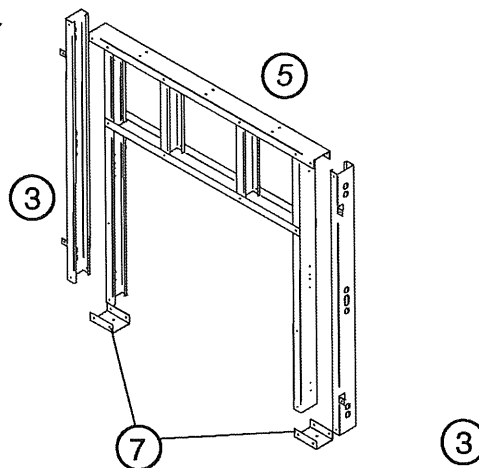

4. Secure to Existing Framing

- Secure the frame assembly to existing framing through the stud header (5) and the stud plates (7).

6. Install Concrete Board Top and Sides

- Use drywall screws (10) to install the concrete board top (8) and sides (9), Fig. #79.

Fig. #78

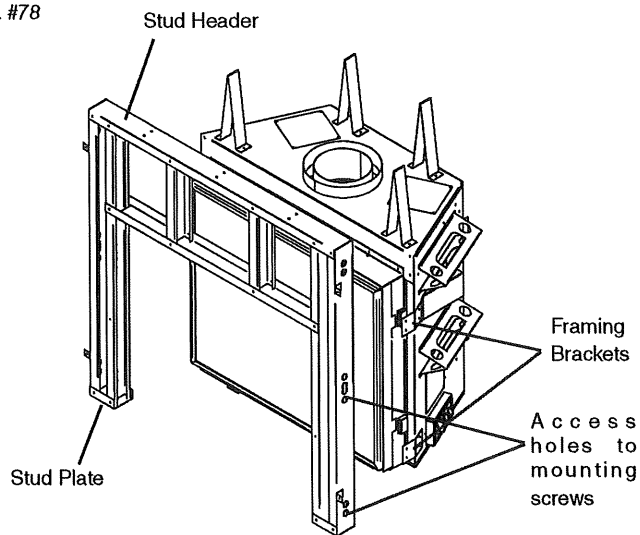
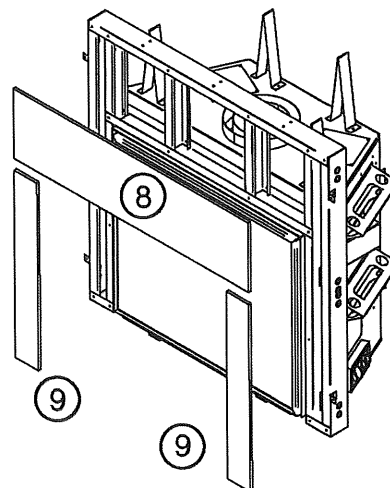

Fig. #79



NOTES:

NOTES:



**VENTED GAS FIREPLACE - NOT FOR USE WITH SOLID FUEL
FOYER AU GAZ À ÉVACUATION - NE PAS UTILISER AVEC
DU COMBUSTIBLE SOLIDE**

WH-

ANSI Z21.50b-2002 / CSA 2.22b-2002 Vented Gas Fireplaces
CAN/CGA 2.17-M91 Gas-Fired Appliance For Use At High Altitudes.
Certified for / Certifié pour Canada and U.S.A.

This Appliance is Equipped For Use With /
Cet Appareil est Équipé Pour Utiliser Avec :

NATURAL GAS LP-GAS
GAZ NATUREL LP GAZ

TOWN & COUNTRY
FIREPLACES™

MODEL/ **TC36**
MODELE: **TC36AR**

SERIES/
SERIE: **C**

MADE IN CANADA
FABRIQUE AU CANADA

FOR USE WITH/ EN CASE D'EMPLOI AVEC:	NATURAL GAS/ DU GAZ NATUREL	LP GAS/ DU GAZ LP
Minimum supply pressure / Pression minimum d'alimentation: (For the purpose of input adjustment / dans le but de régler l'alimentation)	5.0 in/wc / 5.0 po/c.e. (1.25 kPa)	12.5 in/wc / 12.5 po/c.e. (3.11 kPa)
Maximum supply pressure / Pression maximum d'alimentation:	13.9 in/wc / 13.9 po/c.e. (3.45 kPa)	13.9 in/wc / 13.9 po/c.e. (3.45 kPa)
Manifold pressure / Pression de la tuyauterie: Maximum	3.8 in/wc / 3.8 po/c.e. (.95 kPa)	11.0 in/wc / 11.0 po/c.e. (2.74 kPa)
Orifice Size / Diamètre de l'injecteur:	# 30 (3.26 mm)	# 45 (2.08 mm)
Input BTU/hr (kW) / Entree BTU/h (kW):	Max.: 47,000 (13.8) Min.: 35,000 (10.3)	Max.: 47,000 (13.8) Min.: 35,000 (10.3)

Optional components: Remote Heat Kit (TC36.RHKA), / Éléments facultatifs: Kit à Distance de la Chaleur (TC36.RHKA); Blower electrical rating: 115v, 60hz, 0.5 A / Normes électriques du ventilateur: 115v, 60hz, 0.5 A
This appliance equipped for altitudes 0 - 4500 ft. (0 - 1372 m) / Cet unité est conçu pour des altitudes variant entre 0 - 4500 pieds (0 - 1372 m). In Canada, also certified for installation in a bedroom or a bed sitting room / Aussi certifié pour installation dans une chambre à coucher ou une aile de séjour. This appliance must be installed in accordance with local codes, if any; if none, follow the current CAN/CGA-B149 (Canada), or ANSI Z223.1 (USA) Installation Codes. Installer l'appareil selon les codes ou règlements locaux, ou, en l'absence de tels règlements, selon les codes d'installation CAN/CGA-B149 (Canada), or ANSI Z223.1 (USA) en vigueur.

MANUFACTURED (MOBILE) HOME: This appliance is only for use with the type of gas indicated on the rating plate and may be installed in an aftermarket, permanently located, manufactured (mobile) home where not prohibited by local codes. See owners manual for details.
FABRIQUEZ (MOBILE) MAISON: Cet appareil doit être utilisé uniquement avec le type de gaz indiqué sur la plaque signalétique et peut être installé dans une maison préfabriquée (mobile) installée à demeure si les règlements locaux le permettent. Voir la notice du propriétaire pour plus de détails. Cet appareil ne peut être converti à d'autres gaz sauf si une trousse de conversion certifiée est utilisée.
Install in accordance with the current standard Mobile Homes, CAN/CSA Z240 MH (in CANADA), and the Manufacturer's Home Construction and Safety Standard, Title 24 CFR, Part 3280, or the current Standard for Fire Safety Criteria for Manufactured Home Installations, Sites, and Communities ANSI/NFPA 501A, (in the U.S.A.). Cet appareil doit être installé conformément aux exigences de la norme CAN/CSA Z240 MH en vigueur de l'ACNOR, Installations de gaz dans les Constructions Mobiles.
FOR USE WITH GLASS DOORS CERTIFIED WITH THE APPLIANCE ONLY / POUR UTILISATION UNIQUEMENT AVEC LES PORTES EN VERRE CERTIFIÉES AVEC L'APPAREIL

MINIMUM CLEARANCES TO COMBUSTIBLES / CLAIRANCES MINIMALES AVEC LES COMBUSTIBLE		
Left and Right side are determined when facing the front of the appliance. / Les côtés droit et gauche se déterminent en se mettant devant l'appareil et en lui faisant face.		
Top, Back and Side Standoffs / Sommet, Arrière et Côté Butée	0 in/ 0 po.	(0 mm)
Sidewall to Appliance / Du mur latéral à l'appareil	4 in/ 4 po.	(102 mm)
Ceiling to Appliance / Plafond à l'appareil	24 in/ 24 po.	(610 mm)
Mantel to Appliance / Du manteau à l'appareil	*9 in/ 9 po.	(229 mm)
Maximum Mantel Extension / Allongement maximum du manteau	*12 in/ 12 po.	(305 mm)
*See Installation Manual for more detail / Voyez des Directives de l'Installation pour plus détails.		
Mantel Supports / Supports du manteau	4 in/ 4 po.	(102 mm)
Vent Pipe / Déchargez le Tuyau	1.75 in/ 1.75 po.	(45 mm)

Pacific Energy
Fireplace Products Ltd.
Duncan, British Columbia,
Canada



WARNING: Improper installation, adjustment, alteration, service or maintenance can cause injury or property damage. Refer to the owner's information manual provided with this appliance. For assistance or additional information, consult a qualified installer, service agency or the gas supplier.
AVERTISSEMENT: Une installation, un réglage, une modification, une réparation ou un entretien mal effectué peut causer des dommages matériels ou des blessures. Voir la notice de l'utilisateur qui accompagne l'appareil. Pour de l'aide ou des renseignements supplémentaires, consultez un installateur, un technicien agréé ou le fournisseur de gaz.

190506

5050.7205.C

1-TC36-C

SAFETY LABEL LOCATION

NOTE: The Safety Label is located on a plate found in a slot between the left hand side lintel and the left hand side window frame. This plate is attached to the lintel with a cable.



TOWN & COUNTRY
FIREPLACES™

Phone: 1-877-715-2664
www.townandcountryfireplaces.net
2975 Allenby Rd., Duncan, BC V9L 6V8

BUILDING PERMIT INSPECTION PROCEDURES

Please call 874-8703 or 874-8693 (ONLY)

to schedule your inspections as agreed upon

Permits expire in 6 months, if the project is not started or ceases for 6 months.

The Owner or their designee is required to notify the inspections office for the following inspections and provide adequate notice. Notice must be called in 48-72 hours in advance in order to schedule an inspection:

By initializing at each inspection time, you are agreeing that you understand the inspection procedure and additional fees from a "Stop Work Order" and "Stop Work Order Release" will be incurred if the procedure is not followed as stated below.

A Pre-construction Meeting will take place upon receipt of your building permit.

- Footing/Building Location Inspection: Prior to pouring concrete
- Re-Bar Schedule Inspection: Prior to pouring concrete
- Foundation Inspection: Prior to placing ANY backfill
- Framing/Rough Plumbing/Electrical: Prior to any insulating or drywalling
- Final/Certificate of Occupancy: Prior to any occupancy of the structure or use. NOTE: There is a \$75.00 fee per inspection at this point.

Certificate of Occupancy is not required for certain projects. Your inspector can advise you if your project requires a Certificate of Occupancy. All projects **DO** require a final inspection

If any of the inspections do not occur, the project cannot go on to the next phase, REGARDLESS OF THE NOTICE OR CIRCUMSTANCES.

CERIFICATE OF OCCUPANICES MUST BE ISSUED AND PAID FOR, BEFORE THE SPACE MAY BE OCCUPIED

Jessica Dearborn 2/7/08
Signature of Applicant/Designee Date

Rose Campbell 2/7/08
Signature of Inspections Official Date

CBL: 38-F009 Building Permit #: 08-0031