

**City of Portland, Maine - Building or Use Permit Application**

389 Congress Street, 04101 Tel: (207) 874-8703, Fax: (207) 874-8716

Permit No: 10-1285	Issue Date:	CBL: 038 F006001
-----------------------	-------------	---------------------

Location of Construction: 245 Commercial St	Owner Name: Casco View Holdings Llc	Owner Address: Po Box 11409	Phone:
Business Name:	Contractor Name: Simplex / Grinnell	Contractor Address: 20 Thomas Drive Westbrook	Phone: 2078426440
Lessee/Buyer's Name	Phone:	Permit Type: Fire Alarm System	Zone: B-3

Part Use: Commercial	Proposed Use: Commercial / Install fire alarm system on the 5th floor	Permit Fee: \$100.00	Cost of Work: \$7,500.00	CEO District: 1
FIRE DEPT: <input checked="" type="checkbox"/> Approved <input type="checkbox"/> Denied *See Conditions		INSPECTION: Use Group: U Typ Alarm NPPA / IBC 2005		

Proposed Project Description:  
Install fire alarm system on the 5th floor

Signature: *(KG)*

PED-ESTRIAN ACTIVITIES DISTRICT (P.A.D.)

Action:  Approved  Approved w/Conditions  Denied

Signature: \_\_\_\_\_ Date: \_\_\_\_\_

Permit Taken By: gg	Date Applied For: 10/14/2010	<b>Zoning Approval</b>	
------------------------	---------------------------------	------------------------	--

1. This permit application does not preclude the Applicant(s) from meeting applicable State and Federal Rules.  2. Building permits do not include plumbing, septic or electrical work.  3. Building permits are void if work is not started within six (6) months of the date of issuance. False information may invalidate a building permit and stop all work.	Special Zone or Reviews <input type="checkbox"/> Shoreland <input type="checkbox"/> Wetland <input type="checkbox"/> Flood Zone <input type="checkbox"/> Subdivision <input type="checkbox"/> Site Plan <input type="checkbox"/> Maj <input type="checkbox"/> Minor <input type="checkbox"/> MM	Zoning Appeal <input type="checkbox"/> Variance <input type="checkbox"/> Miscellaneous <input type="checkbox"/> Conditional Use <input type="checkbox"/> Interpretation <input type="checkbox"/> Approved <input type="checkbox"/> Denied	Historic Preservation within <input type="checkbox"/> Not in District or Landmark <input type="checkbox"/> Does Not Require Review <input type="checkbox"/> Requires Review <input type="checkbox"/> Approved <input type="checkbox"/> Approved w/Conditions <input type="checkbox"/> Denied
	Date: <i>10/10/10</i>		Date: <i>Review's Approval</i>

**PERMIT ISSUED**

NOV - 5 2010

City of Portland

**CERTIFICATION**

I hereby certify that I am the owner of record of the named property, or that the proposed work is authorized by the owner of record and that I have been authorized by the owner to make this application as his authorized agent and I agree to conform to all applicable laws of this jurisdiction. In addition, if a permit for work described in the application is issued, I certify that the code official's authorized representative shall have the authority to enter all areas covered by such permit at any reasonable hour to enforce the provision of the code(s) applicable to such permit.

SIGNATURE OF APPLICANT	ADDRESS	DATE	PHONE
RESPONSIBLE PERSON IN CHARGE OF WORK, TITLE		DATE	PHONE

**City of Portland, Maine - Building or Use Permit**

389 Congress Street, 04101 Tel: (207) 874-8703. Fax: (207) 874-8716

Permit No: 10-1285	Date Applied For: 10/12/2010	CBL: 038 F006001
-----------------------	---------------------------------	---------------------

Location of Construction: 245 Commercial St	Owner Name: Casco View Holdings Llc	Owner Address: Po Box 11409	Phone:
Business Name:	Contractor Name: Simplex / Grinnell	Contractor Address: 20 Thomas Drive Westbrook	Phone: (207) 842-6440
Lessee/Buyer's Name	Phone:	Permit Type: Fire Alarm System	

Proposed Use: Commercial / Install fire alarm system on the 5th floor	Proposed Project Description: Install fire alarm system on the 5th floor
--	---

Dept: Zoning      Status: Approved with Conditions      Reviewer: Marge Schmuckal      Approval Date: 10/18/2010

Note: Ok to Issue: ✓

- 1) ANY exterior work requires a separate review and approval thru Historic Preservation. This property is located within an Historic District.
- 2) Separate permits shall be required for any new signage.
- 3) This permit is being approved on the basis of plans submitted. Any deviations shall require a separate approval before starting that work.

Dept: Building      Status: Approved with Conditions      Reviewer: Tammy Munson      Approval Date: 11/05/2010

Note: Ok to Issue: ✓

- 1) Fire Alarm systems shall be installed per Sec. 907 of the IBC 2003

Dept: Fire      Status: Approved with Conditions      Reviewer: Capt Keith Gautreau      Approval Date: 10/26/2010

Note: Ok to Issue: ✓

- 1) The Fire alarm and Sprinkler systems shall be reviewed by a licensed contractor[s] for code compliance. Compliance letters are required.
- 2) The fire alarm system shall comply with the City of Portland Standard for Signaling Systems for the Protection of Life and Property. All fire alarm installation and servicing companies shall have a Certificate of Fitness from the Fire Department.
- 3) As-built documents shall be submitted in pdf to the Building Inspections Office upon completion of job.
- 4) System acceptance and commissioning must be co-ordinated with alarm and suppression system contractors and the Fire Department. Call 874-8703 to schedule.
- 5) All fire alarm records required by NFPA 72 should be stored in an approved cabinet located at the FACP labeled "FIRE ALARM RECORDS". Records cabinet, FACP, annunciator(s), and pull stations shall be keyed alike.

**PERMIT ISSUED**

NOV - 5

## **BUILDING PERMIT INSPECTION PROCEDURES**

**Please call 874-8703 or 874-8693 (ONLY )**

**or email: [buildinginspections@portlandmaine.gov](mailto:buildinginspections@portlandmaine.gov)**

With the issuance of this permit, the owner, builder or their designee is required to provide adequate notice to the City of Portland Inspection Services for the following inspections. Appointments must be requested 48 to 72 hours in advance of the required inspection. The inspection date will need to be confirmed by this office.

- **Please read the conditions of approval that is attached to this permit!! Contact this office if you have any questions.**
- **Permits expire in 6 months, if the project is not started or ceases for 6 months.**
- **If the inspection requirements are not followed as stated below additional fees may be incurred due to the issuance of a "Stop Work Order" and subsequent release to continue with construction.**

  X   **Final inspection required at completion of work performed by the Fire Department.**

**The project cannot move to the next phase prior to the required inspection and approval to continue, REGARDLESS OF THE NOTICE OR CIRCUMSTANCES.**

**IF THE PERMIT REQUIRES A CERTIFICATE OF OCCUPANCY, IT MUST BE PAID FOR AND ISSUED TO THE OWNER OR DESIGNEE BEFORE THE SPACE MAY BE OCCUPIED.**

**PERMIT ISSUED**

**NOV - 5 2011**

**City of Portland**

Simplex Grinnell  
20 Thomas Drive  
Westbrook ME 04092



# Fire Alarm Permit

If you or the property owner owes real estate or property taxes or user charges on any property within the city, payment arrangements must be made before permits of any kind are accepted.

Installation address: MEMIC 245 Commercial ST CBL: 038 F 006

Exact location: (within structure) 5th Floor

Type of occupancy(s) (NFPA & ICC) \_\_\_\_\_

Building owner: MEMIC

System Designer (point of contact): Must be Ken Plourde

Designer phone: 207-482-2324 E-mail: kplourde@simplexgrinnell.com

Installing contractor: SimplexGrinnell Certificate of Fitness No: 1019

Contractor phone: 842-6440 E-mail: pdoughty@simplexgrinnell.com

This is a new application: YES  NO  New AES Master Box: YES  NO   
(Include Master Box approval form)

Amendment to an existing permit: YES  NO  Permit no: \_\_\_\_\_

The following documents shall be provided with this application:

- Floor plans
- Scope of Work
- Wiring diagram
- 11 1/2 x 17s
- Annunciator details
- pdf copy (may be e-mailed)
- Input/ Output Matrix
- Designer qualifications
- Equipment data sheets
- Battery/ voltage drop calcs
- Electrical Permit Pulled (check alarm/com)

Master box approval only: YES  NO   
(If yes check *New AES Master Box* above)

COST OF WORK: \$ 7500.00

PERMIT FEE: ~~\$400~~ 100.00  
(\$10 PER \$1,000 + \$30 FOR THE FIRST \$1,000)

RECEIVED

OCT 12

Dept. of Building Inspection  
City of Portland, Maine

The designer shall be the responsible party for this application. Download a new copy of this application at [www.portlandmaine.gov/fire](http://www.portlandmaine.gov/fire) for every submittal. Submit all plans in electronic PDF in addition to readable 11 1/2 x 17s to the Building Inspections Department, 389 Congress Street, Room 315, Portland, Maine 04101.

Prior to acceptance of any fire alarm system, a complete commissioning and acceptance test must be coordinated with all fire system contractors and the Fire Department, and proper documentation of such test(s) provided.

All installation(s) must comply with the *City of Portland Technical Standard for Signaling Systems for the Protection of Life and Property*, available at [www.portlandmaine.gov/fire](http://www.portlandmaine.gov/fire).

Applicant signature: Ken Plourde Date: 10/8/10

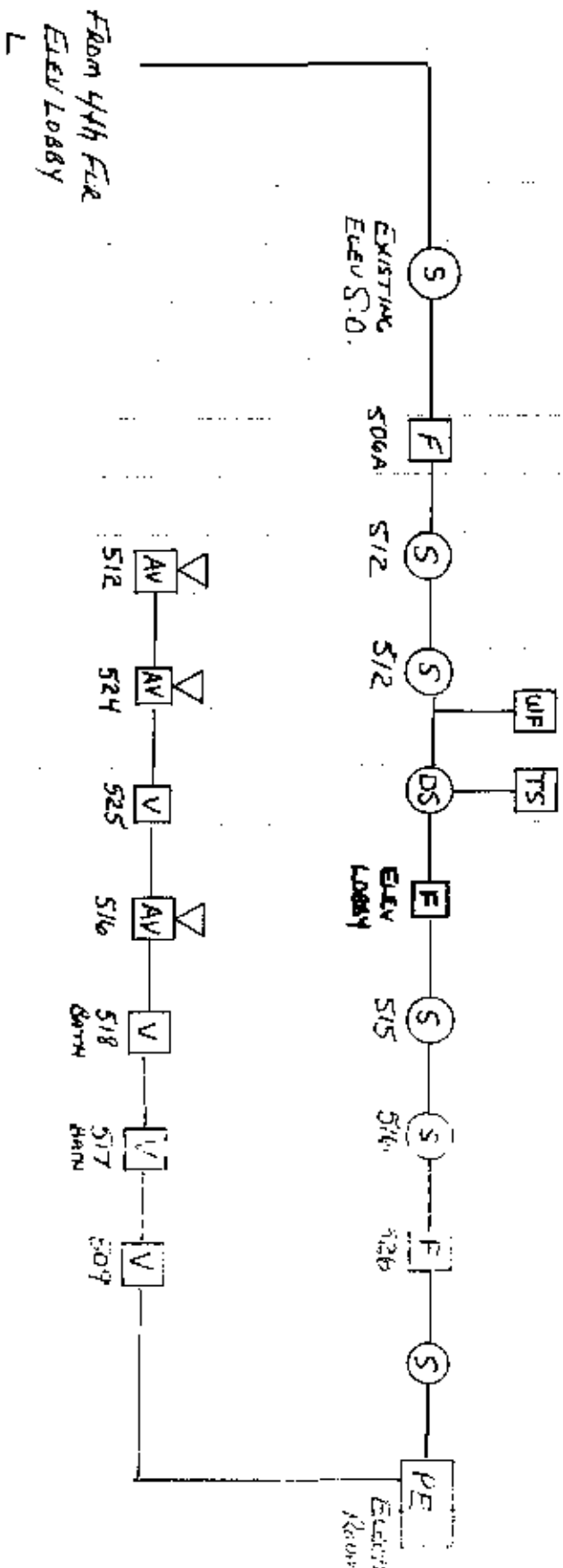

**SimplexGrinnell** SP-SAFF



**Ken Plourde**  
 Service Sales Representative  
 Alarm & Detection Division

21 Thomas Drive  
 Westbrook, ME 04092  
 Mext: 088704  
 F: 207-482-2824 C: 207-749-8726  
 kplourde@simplexgrinnell.com • www.simplexgrinnell.com

*MEMIC 5TH FLR 245 COMMERCIAL*





**CITY OF PORTLAND, MAINE**  
Department of Building Inspections

**Original Receipt**

DETA PAID

Received from

Jennifer V. [unclear]

Amount of Contribution \$ \_\_\_\_\_ Building Fee: \_\_\_\_\_

Inspection Fee \$ \_\_\_\_\_ Site Fee: \_\_\_\_\_

Certificate of Occupancy Fee: \_\_\_\_\_

Tenant: [unclear]

Building (B)  Planning (P) \_\_\_\_\_ Electrical (E) \_\_\_\_\_ Site (S) \_\_\_\_\_

Other FEELER COVER

OR: 035 F 006

Check # 1100 Total Collected 1100

No work is to be started until the permit is issued.  
Please keep original receipt for your records.

Taken by: [Signature]

WHITE - Applicant's Copy  
YELLOW - Office Copy  
PINK - Permit Copy