

DISPLAY THIS CARD ON PRINCIPAL FRONTAGE OF WORK CITY OF PORTLAND

BUILDING INSPECTION

Permit Number: 030237

Please Read
Application And
Notes, If Any,
Attached

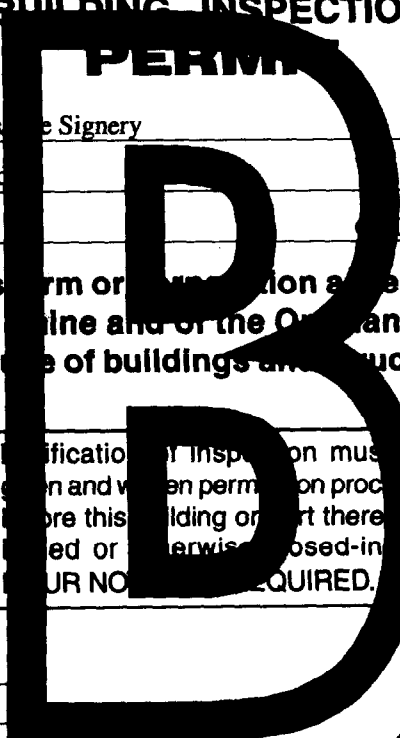

This is to certify that 245 Commercial St Partners Signery
as permission to Erect 48"x36" Sign on Building
at 245 Commercial St L 038 F006001

Provided that the person or persons who apply for or accept this permit shall comply with all of the provisions of the Statutes of this State and of the Ordinances of the City of Portland regulating the construction, maintenance and use of buildings and structures, and of the application on file in this department.

Apply to Public Works for street line and grade if nature of work requires such information.

Notification of Inspection must be given and when permission is procured before this building or part thereof is occupied or otherwise proposed-in-4
YOUR NOTICE REQUIRED.

A certificate of occupancy must be procured by owner before this building or part thereof is occupied.

OTHER REQUIRED APPROVALS

Fire Dept. _____
Health Dept. _____
Appeal Board _____
Other _____
Department Name

[Handwritten Signature]
Director - Building & Inspection Services
5/2/03

PENALTY FOR REMOVING THIS CARD

03-0237

THIS IS NOT A PERMIT/CONSTRUCTION MAY NOT COMMENCE UNTIL THE PERMIT IS ISSUED

Signage Application

If you or the property owner owes real estate or personal property taxes or user charges on any property within the City, payment arrangements must be made before permits of any kind are accepted.

Location/Address of Construction: <u>245 Commercial Street</u>		
Total Square Footage of ^{existing} Proposed Structure <u>~34,340 sq ft</u>	Square Footage of Lot <u>9393 SF</u>	
Tax Assessor's Chart, Block & Lot Chart# <u>038-F-006-001</u> Block# Lot#	Owner: <u>245 Commercial Street Partners, LLP</u>	Telephone: <u>772-1941</u>
Tenant Lessee/Buyer's Name (If Applicable) <u>Drummond, Woodsum & MacMahon</u>	Applicant name, address & telephone: <u>Drummond Woodsum & MacMahon 245 Commercial St Portland ME 04101 772 1941</u>	Total s.f. of signage <u>12 x</u> 1.00 per s.f. \$ <u>12</u> , plus \$30.00 base fee Fee: \$ <u>42.</u>
Current use: <u>Law Firm</u>		
If the location is currently vacant, what was prior use: <u>N/A</u>		
Approximately how long has it been vacant: _____		
Proposed use: <u>Install Street Sign at 245 Commercial Street</u> Project description:		
Contractor's name, address & telephone: <u>The Signery, Forest Ave, 879-7700 Cathy Lister</u>		
Who should we contact when the permit is ready: <u>Cathy Lister</u>		
Mailing address: <u>c/o Drummond Woodsum & MacMahon 245 Commercial St, Portland ME 04101</u>		
We will contact you by phone when the permit is ready. You must come in and pick up the permit and review the requirements before starting any work, with a Plan Reviewer. A stop work order will be issued and a \$50.00 fee if any work starts before the permit is picked up. Phone: <u>772.1941</u>		

IF THE REQUIRED INFORMATION IS NOT INCLUDED IN THE SUBMISSIONS THE PERMIT WILL BE AUTOMATICALLY DENIED AT THE DISCRETION OF THE BUILDING/PLANNING DEPARTMENT, WE MAY REQUIRE ADDITIONAL INFORMATION IN ORDER TO APPROVE THIS PERMIT.

I hereby certify that I am the Owner of record of the named property, or that the owner of record has authorized me to make this application as his/her authorized agent. I agree to conform to all applicable laws of this jurisdiction. In addition, if a permit for work described in this application is issued, I certify that the City Official's authorized representative shall have the authority to enter all areas covered by this permit at any reasonable hour to enforce the provisions of the codes applicable to this permit.

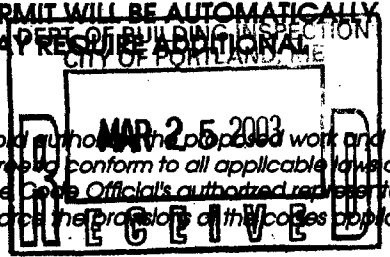

Signature of applicant: <u>Cathy Lister</u>	Date: <u>March 21, 2003</u>
---	-----------------------------

This is NOT a permit. you may not commence ANY work until the permit is issued.

SIGNAGE PRE-APPLICATION

PLEASE ANSWER ALL QUESTIONS

B-3

ADDRESS: 245 Commercial Street ZONE: Historic

OWNER: 245 Commercial Street Partners LLP

APPLICANT: Drummond Woodsum; MacMahon

ASSESSOR NO. Account # 5802; CBL 038-F-006-001

PLEASE CIRCLE APPROPRIATE ANSWER

SINGLE TENANT LOT? YES NO MULTI-TENANT LOT? YES NO
FREESTANDING SIGN? (ex. Pole Sign) YES NO DIMENSIONS _____ HEIGHT _____

MORE THAN ONE SIGN? YES NO DIMENSIONS _____ HEIGHT _____

SIGN ATTACHED TO BLDG.? YES NO DIMENSIONS ~12 sq. ft. (3x4) = 12 #

MORE THAN ONE SIGN? YES NO DIMENSIONS _____

AWNING: YES NO IS AWNING BACKLIT? YES NO HEIGHT OFF SIDEWALK _____
IS THERE ANY MESSAGE, TRADEMARK OR SYMBOL ON IT? not on Commercial St.

LIST ALL EXISTING SIGNAGE AND THEIR DIMENSIONS: - See photos enclosed

Flyte New Media - 6.75 sq. ft
Addecco - unknown, but < Flyte sign (see photos)

*** TENANT BLDG. FRONTAGE (IN FEET): est. 96 feet Commercial St. frontage

*** REQUIRED INFORMATION

96 x 2 = 192 # max allowable

AREA FOR COMPUTATION

YOU SHALL PROVIDE:

A SITE SKETCH AND BUILDING SKETCH SHOWING EXACTLY WHERE EXISTING AND NEW SIGNAGE IS LOCATED MUST BE PROVIDED. SKETCHES AND/OR PICTURES OF PROPOSED ARE ALSO REQUIRED.

SIGNATURE OF APPLICANT: Caroline Lyster

DATE: 3/21/03

2 of 3

THE Signery



299 FOREST AVE.
PORTLAND, ME. 04101
TEL: 879-7700
FAX: 879-1570

TO: CITY OF PORTLAND - CODE ENFORCEMENT
ATTN: MIKE NUGENT
FROM: DON WRIGHT
DATE: 4/4
FAX: 874-8716
PHONE:

NOW OFFERING

CALL TO FIND OUT ABOUT OUR NEW CAPABILITIES...

UNIQUE DIMENSIONAL SIGNS

ELECTRIFIED SIGNAGE

LARGE FORMAT PRINTING
CARVING AND GOLD LEAFING

ARCHITECTURAL LETTERS

Hi MIKE-

HERE IS A ROUGH SKETCH OF THE BRACKET WE WILL BE FABRICATING FOR THE DRUMMOND WOODSOM SIGN, THE BRACKET IS VERY HEAVY DUTY SUPPORTING OVER 200# - THE SIGN WILL WEIGH ABOUT 50 #.

THE BRACKET WILL BE LAGGED TO THE BUILDING WITH 3/8" GALVANIZED LAGS

THANKS MIKE
DON

3 of 3

Colonial Metal Works

21 Hardy Road
Falmouth, Maine 04105
(207) 797-2463

Bradford L. Crawford

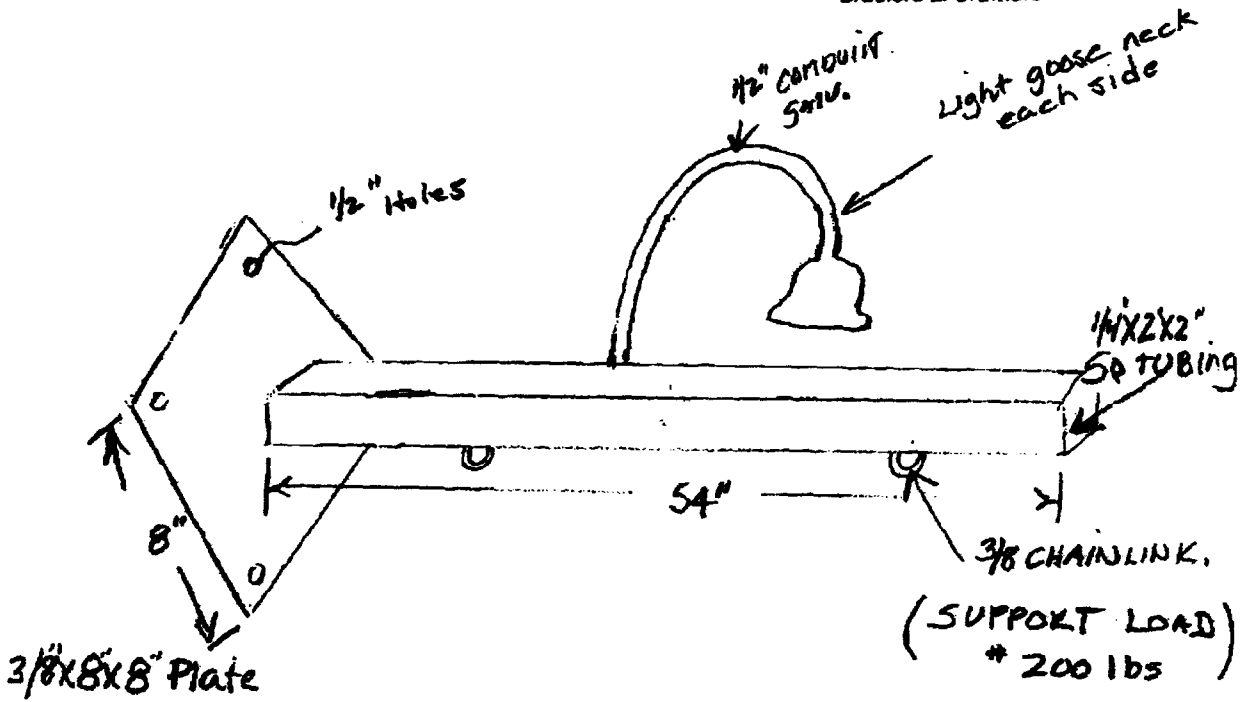

110

ACORD. CERTIFICATE OF LIABILITY INSURANCE		OP ID J3 DRUMM-2	DATE (MM/DD/YY) 03/11/03
PRODUCER Morse, Payson & Noyes P.O. Box 406 Portland ME 04112-0406 Phone: 207-775-6000 Fax: 207-775-0339		THIS CERTIFICATE IS ISSUED AS A MATTER OF INFORMATION ONLY AND CONFERS NO RIGHTS UPON THE CERTIFICATE HOLDER. THIS CERTIFICATE DOES NOT AMEND, EXTEND OR ALTER THE COVERAGE AFFORDED BY THE POLICIES BELOW.	
INSURED Drummond Woodsum & MacMahon PA & Classic Title Company 245 Commercial Street Portland ME 04101		INSURERS AFFORDING COVERAGE	
		INSURER A: Travelers Insurance Company	
		INSURER B:	
		INSURER C:	
		INSURER D:	
		INSURER E:	

COVERAGES

THE POLICIES OF INSURANCE LISTED BELOW HAVE BEEN ISSUED TO THE INSURED NAMED ABOVE FOR THE POLICY PERIOD INDICATED. NOTWITHSTANDING ANY REQUIREMENT, TERM OR CONDITION OF ANY CONTRACT OR OTHER DOCUMENT WITH RESPECT TO WHICH THIS CERTIFICATE MAY BE ISSUED OR MAY PERTAIN, THE INSURANCE AFFORDED BY THE POLICIES DESCRIBED HEREIN IS SUBJECT TO ALL THE TERMS, EXCLUSIONS AND CONDITIONS OF SUCH POLICIES. AGGREGATE LIMITS SHOWN MAY HAVE BEEN REDUCED BY PAID CLAIMS.

INBR LTR	TYPE OF INSURANCE	POLICY NUMBER	POLICY EFFECTIVE DATE (MM/DD/YY)	POLICY EXPIRATION DATE (MM/DD/YY)	LIMITS
A	GENERAL LIABILITY <input checked="" type="checkbox"/> COMMERCIAL GENERAL LIABILITY <input type="checkbox"/> CLAIMS MADE <input checked="" type="checkbox"/> OCCUR GEN'L AGGREGATE LIMIT APPLIES PER: <input type="checkbox"/> POLICY <input type="checkbox"/> PRO-JECT <input type="checkbox"/> LOC	I680945D305A	04/01/02	04/01/03	EACH OCCURRENCE \$ \$1,000,000
	FIRE DAMAGE (Any one fire) \$ \$300,000				
	MED EXP (Any one person) \$ \$5,000				
	PERSONAL & ADV INJURY \$ \$1,000,000				
	GENERAL AGGREGATE \$ \$2,000,000				
	PRODUCTS - COMP/OP AGG \$ \$2,000,000				
AUTOMOBILE LIABILITY <input type="checkbox"/> ANY AUTO <input type="checkbox"/> ALL OWNED AUTOS <input type="checkbox"/> SCHEDULED AUTOS <input type="checkbox"/> HIRED AUTOS <input type="checkbox"/> NON-OWNED AUTOS					COMBINED SINGLE LIMIT (Ea accident) \$ BODILY INJURY (Per person) \$ BODILY INJURY (Per accident) \$ PROPERTY DAMAGE (Per accident) \$
GARAGE LIABILITY <input type="checkbox"/> ANY AUTO					AUTO ONLY - EA ACCIDENT \$ OTHER THAN EA ACC \$ AUTO ONLY: AGG \$
EXCESS LIABILITY <input type="checkbox"/> OCCUR <input type="checkbox"/> CLAIMS MADE <input type="checkbox"/> DEDUCTIBLE <input type="checkbox"/> RETENTION \$					EACH OCCURRENCE \$ AGGREGATE \$ \$ \$ \$
WORKERS COMPENSATION AND EMPLOYERS' LIABILITY					<input type="checkbox"/> WC STATU-TORY LIMITS <input type="checkbox"/> OTH-ER E.L. EACH ACCIDENT \$ E.L. DISEASE - EA EMPLOYEE \$ E.L. DISEASE - POLICY LIMIT \$
OTHER					

DESCRIPTION OF OPERATIONS/LOCATION/VEHICLE/EXCLUSIONS ADDED BY ENDORSEMENT/SPECIAL PROVISIONS
 The City of Portland is listed as additional insured to the general liability coverage, regarding the installation of a street sign.

CERTIFICATE HOLDER	Y	ADDITIONAL INSURED; INSURER LETTER: CITYPOR	CANCELLATION SHOULD ANY OF THE ABOVE DESCRIBED POLICIES BE CANCELLED BEFORE THE EXPIRATION DATE THEREOF, THE ISSUING INSURER WILL ENDEAVOR TO MAIL <u>10</u> DAYS WRITTEN NOTICE TO THE CERTIFICATE HOLDER NAMED TO THE LEFT, BUT FAILURE TO DO SO SHALL IMPOSE NO OBLIGATION OR LIABILITY OF ANY KIND UPON THE INSURER, ITS AGENTS OR REPRESENTATIVES. AUTHORIZED REPRESENTATIVE Morse Payson & Noyes Insurance
City of Portland 389 Congress Street Portland ME 04101			

IMPORTANT

If the certificate holder is an ADDITIONAL INSURED, the policy(ies) must be endorsed. A statement on this certificate does not confer rights to the certificate holder in lieu of such endorsement(s).

If SUBROGATION IS WAIVED, subject to the terms and conditions of the policy, certain policies may require an endorsement. A statement on this certificate does not confer rights to the certificate holder in lieu of such endorsement(s).

DISCLAIMER

The Certificate of Insurance on the reverse side of this form does not constitute a contract between the issuing insurer(s), authorized representative or producer, and the certificate holder, nor does it affirmatively or negatively amend, extend or alter the coverage afforded by the policies listed thereon.

**DRUMMOND
WOODSUM &
MACMAHON**
Attorneys at Law

245 COMMERCIAL STREET
POST OFFICE BOX 9781
PORTLAND, MAINE 04104-5081
(207) 772-1941 FAX (207) 772-3627
TTY (207) 828-8260

March 24, 2003

City of Portland Planning Department

Re: Sign Permit

To Whom It May Concern:

Enclosed please find a completed Signage Application along with the following:

Certificate of Liability insurance;

Letter of permission to install the sign from the building owner/landlord;

Photos of the building frontage with the location of proposed sign indicated;

Photos of other tenant signs currently on the building (Flyte and Adecco);

Sketches from "The Signery" with the general design concept of the sign to be installed, and,

A check in the amount of \$42 (\$30 base fee plus \$12 for 12 square feet).

Because this building is in the Historic District, a site visit was conducted earlier this month by Deb Andrews to assist us in the design and placement of the sign. The sign, primarily dark blue background with gold leaf lettering, will be installed on a bracket similar to that used by Portland Specialty Tile on Commercial Street. The sign will be lit by two small, unobtrusive lighting fixtures, directing spot lights on to both sides of the sign itself.

Please let me know if there is any additional information required for this permit. Thank you in advance for your time.

Sincerely,



Cathy Liston
Chief Operating Officer

245 Commercial Street Partners, LLP

March 13, 2003

Cathy Liston
Drummond Woodsum & MacMahon
245 Commercial Street
Portland, ME 04104

Dear Cathy;

In follow up to our discussion of Monday March 3, 2003, I'm writing to confirm that the 245 Commercial Street Partners, LLP ("Landlord") has approved the installation of a street sign and bracket at the entrance of 245 Commercial Street subject to the following:

- All appropriate permits are secured from the City of Portland;
- Approval is granted from the Historical Society;
- Final design will be compatible with other tenants' signs at 243 and 245 Commercial Street; and,
- Sign will be no larger than 15 square feet with gold leaf lettering on a dark blue background depicting the firm's logo.

Sincerely,
245 Commercial Street Partners, LLP

By: 
Richard A. Carriuolo
Its Managing Partner

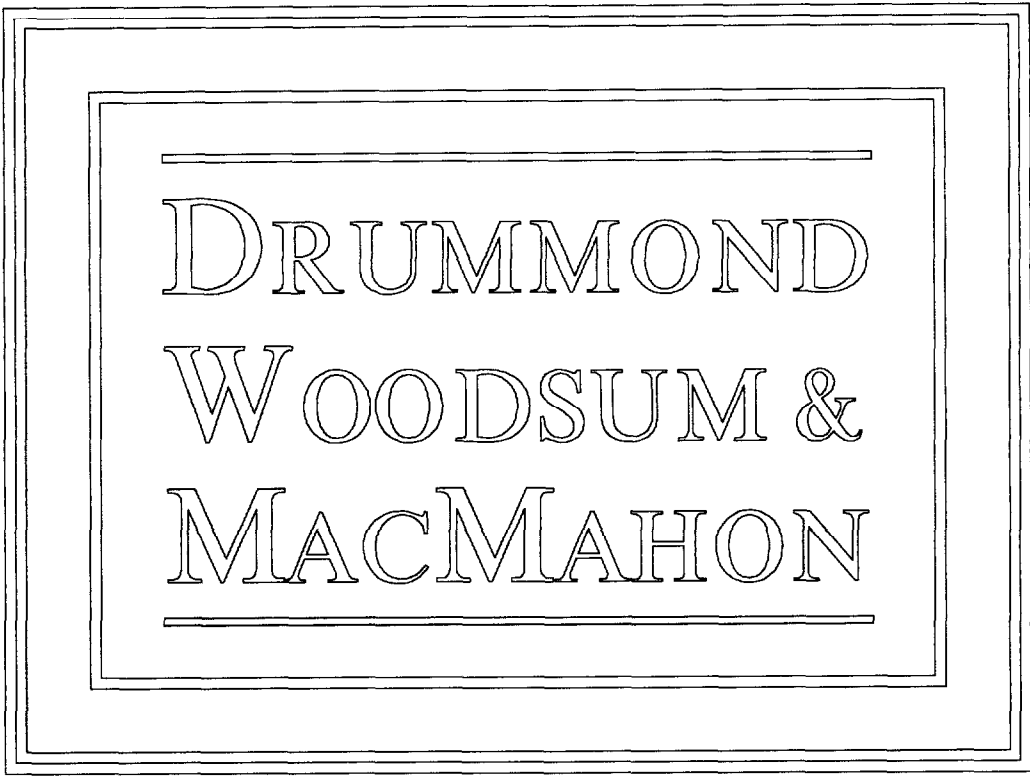

DRUMMOND
WOODSUM &
MACMAHON



36"

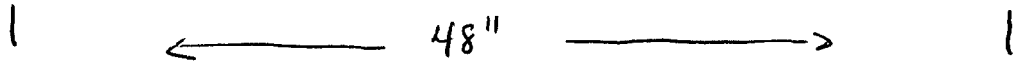

48"

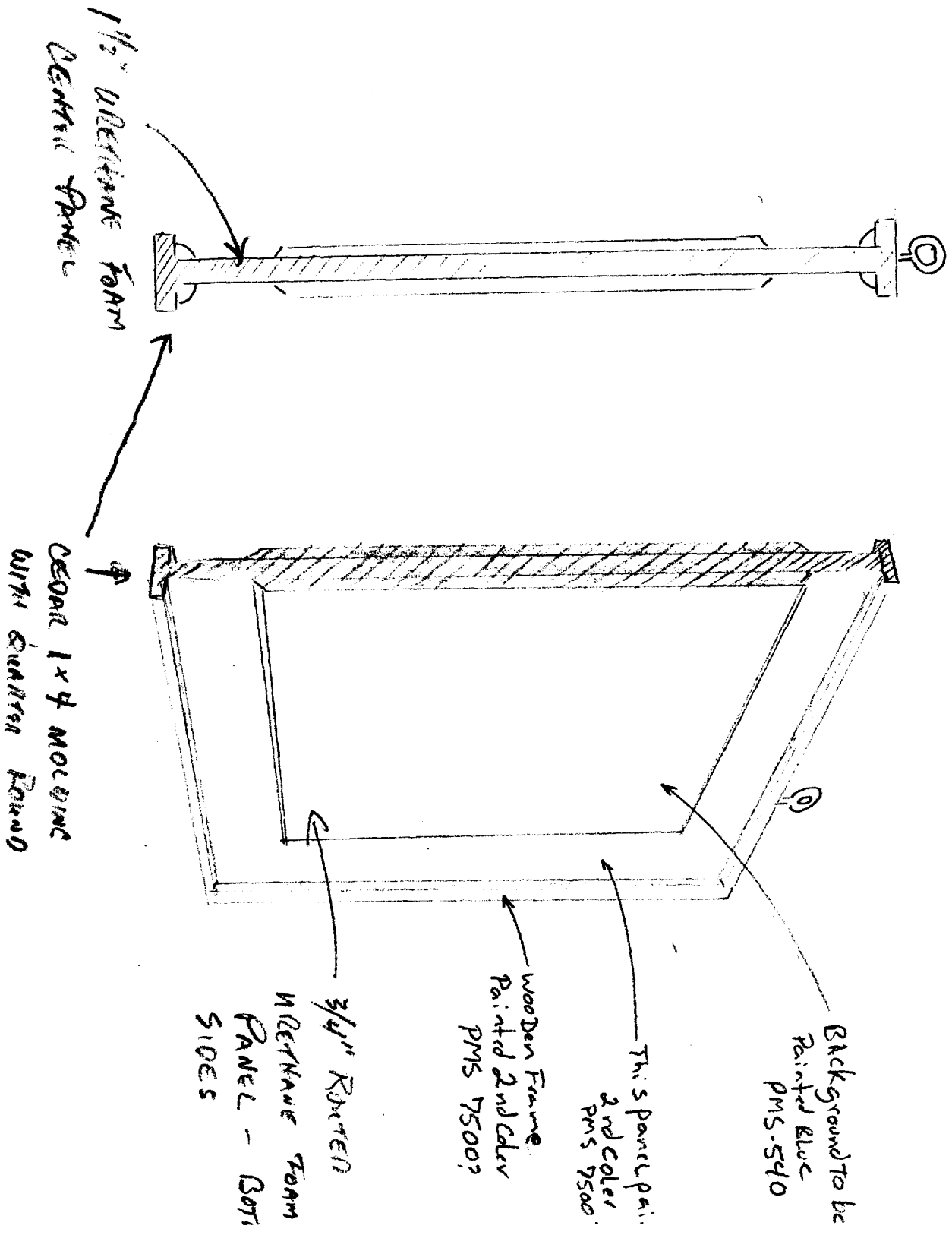

Letter R Pointed a Gold Leaf

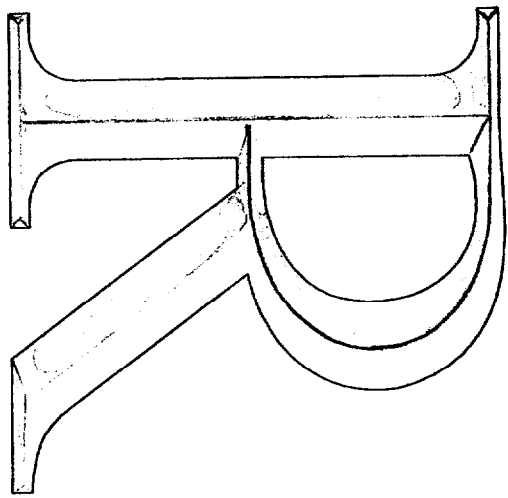
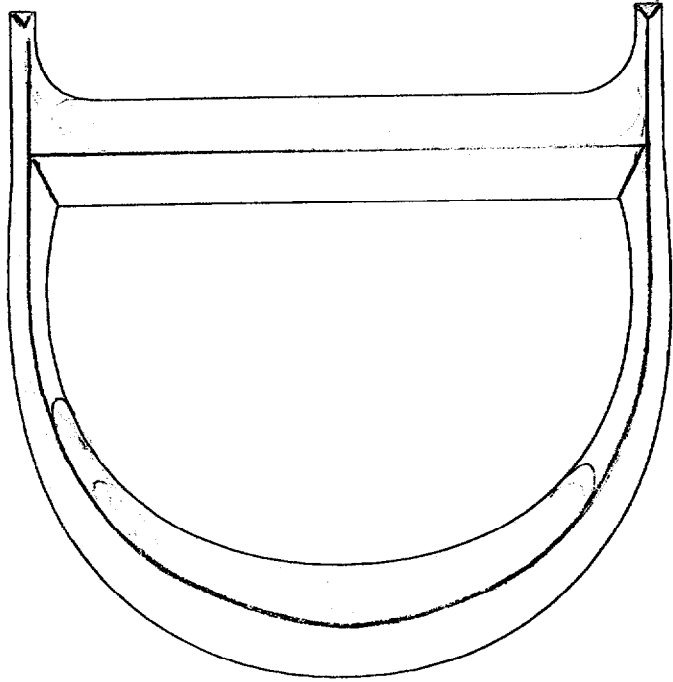

DRUMMOND WOODSUM & MACMATHON
 DRAWING NOT TO SCALE
 See Buildings Photograph for details

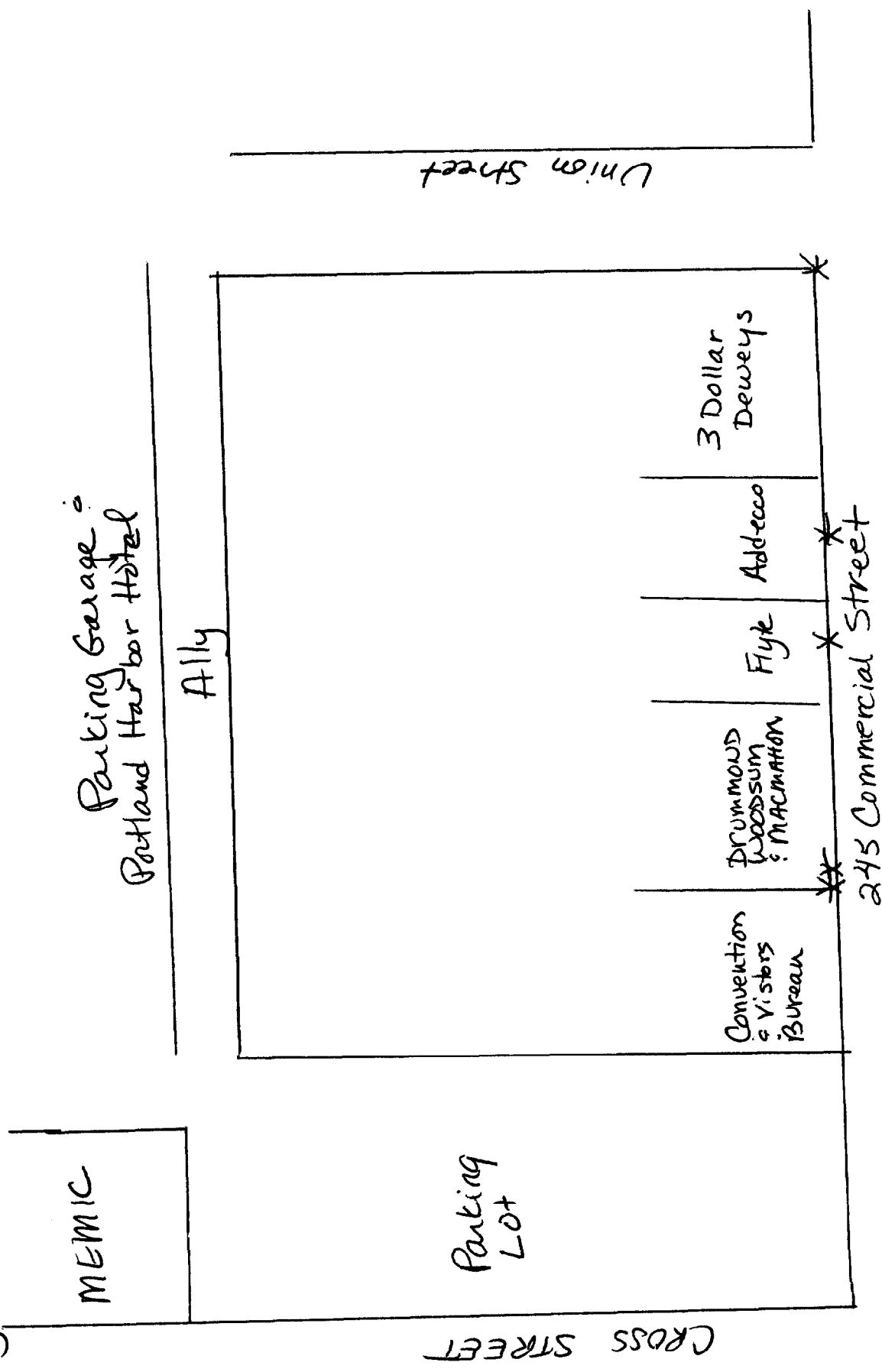

* Existing Signs
 ** Proposed sign location

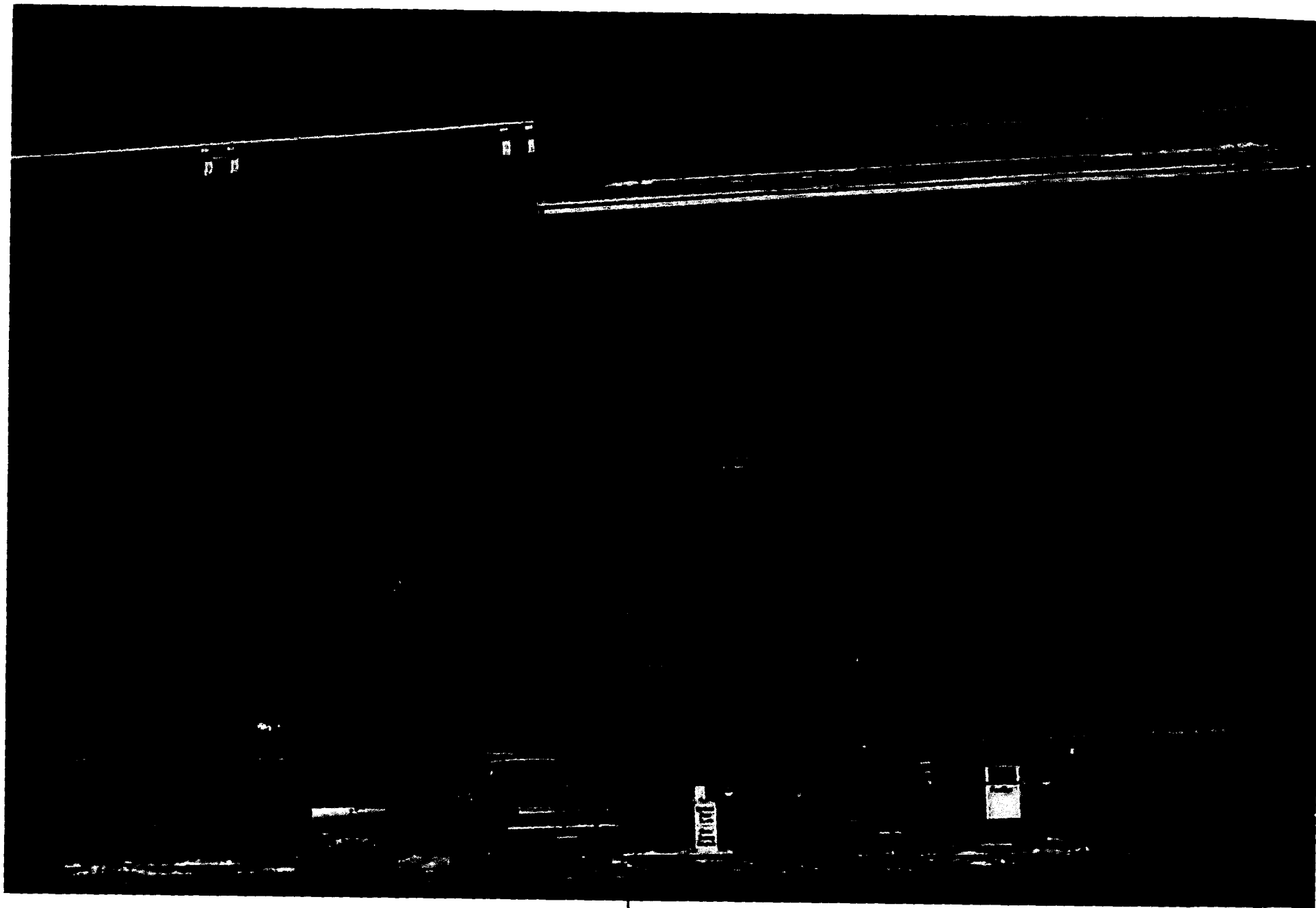

→ Entrance to Drummond Woodsum
* Location of proposed sign.