

NOTE: EXIST. STUDS MAY BE "FLAT-WISE"

\* IF EXIST. SHEATHING IS THICKER THAN 3/4", USE (8) SIMPSON SDS400 SCREWS EVENLY SPACED

1 2nd FLOOR LEDGER SECTION DETAILS  
S-2.2 SCALE: 1 1/2" = 1'-0"

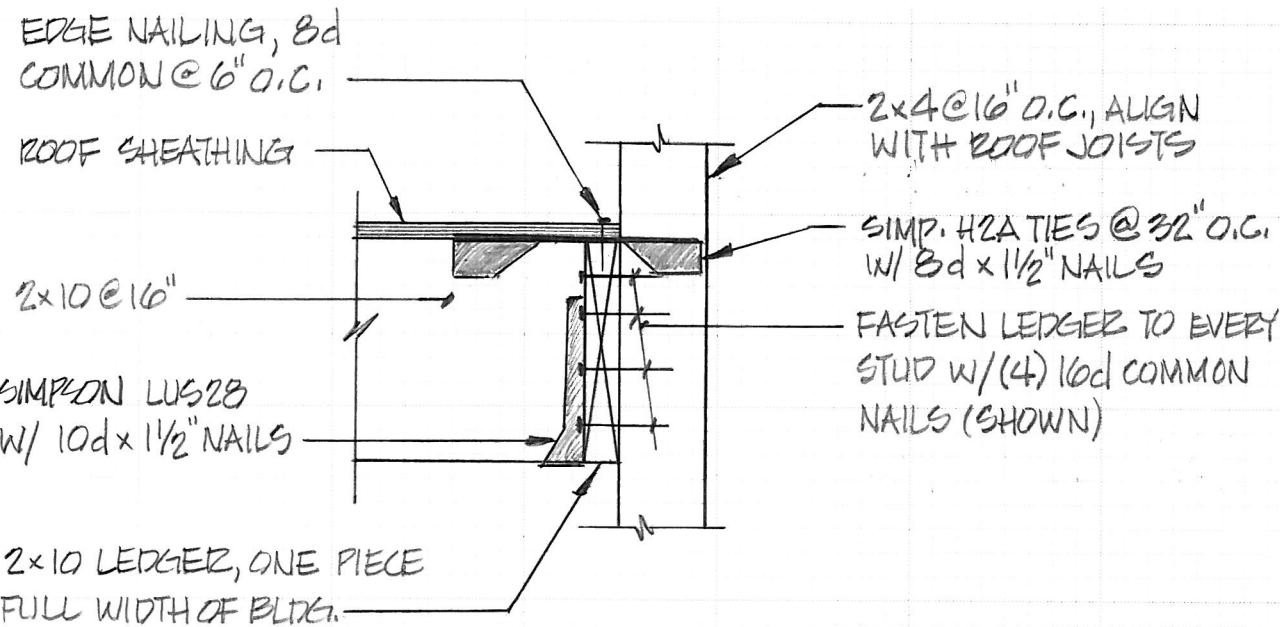
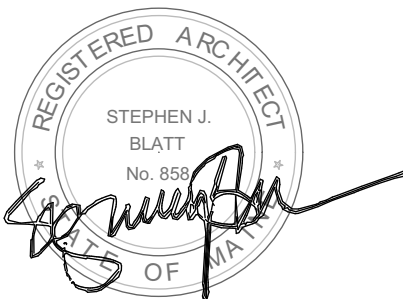

2 LEDGER SECTION DETAIL @ ROOF  
S-2.2 SCALE: 1 1/2" = 1'-0"

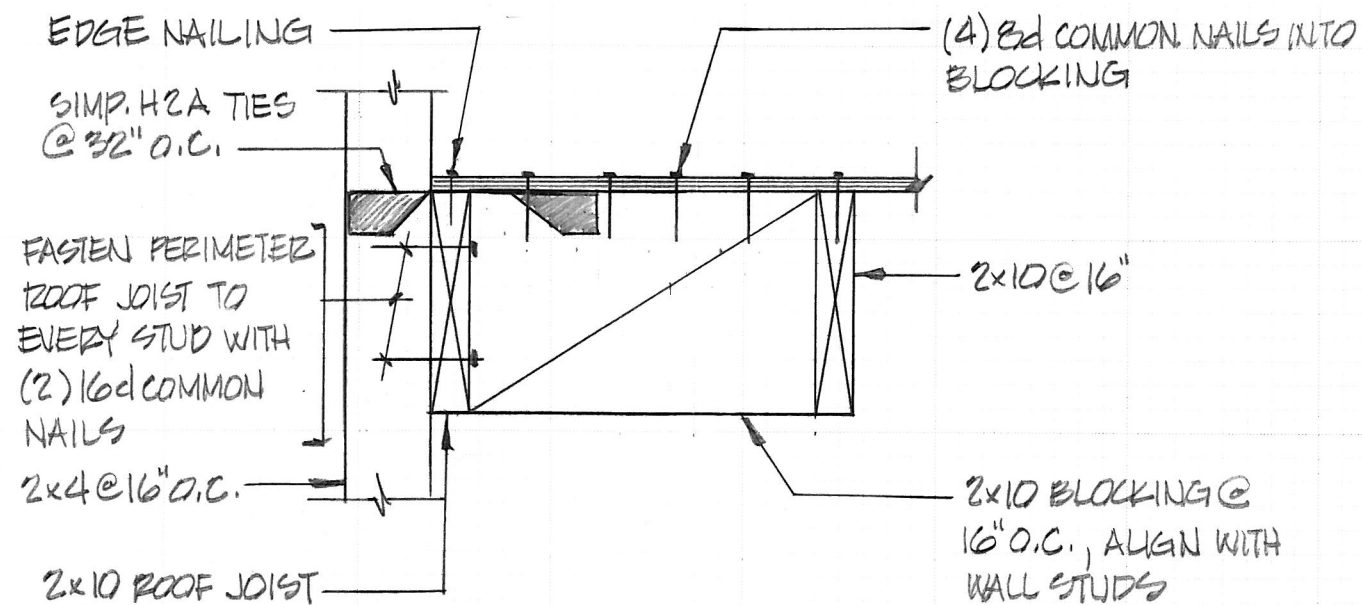

3 ROOF SECTION @ NORTH AND SOUTH WALLS  
S-2.2 SCALE: 1 1/2" = 1'-0"