

## CENTER STREET BOUTIQUE HOTEL PORTLAND, MAINE



THESE DOCUMENTS ARE PARTIALLY DEVELOPED FROM ARCHITECTURAL AND STRUCTURAL DRAWINGS PROVIDED BY OTHERS. ALL AS-BUILT CONDITIONS SHOULD BE FIELD VERIFIED.

**INTERIM REVIEW ONLY**

These documents are incomplete, and are released for interim review only and are not intended for regulatory approval, permit, or construction purposes.

Architect: \_\_\_\_\_  
Arch. Reg. No.: \_\_\_\_\_  
Date: \_\_\_\_\_

**KEY PLAN**

DATUM ELEVATION 12'-0"  
(MSL) = 0.72 INCHES ± 0.70 Portland City Datum



REVISION NO.	DESCRIPTION	DATE

HKS PROJECT NUMBER  
**22302.00**  
DATE  
**12/21/2018**  
ISSUE  
**SCHEMATIC DESIGN**  
SHEET TITLE  
**LANDSCAPE DETAILS**

SHEET NO.  
**L2.00**

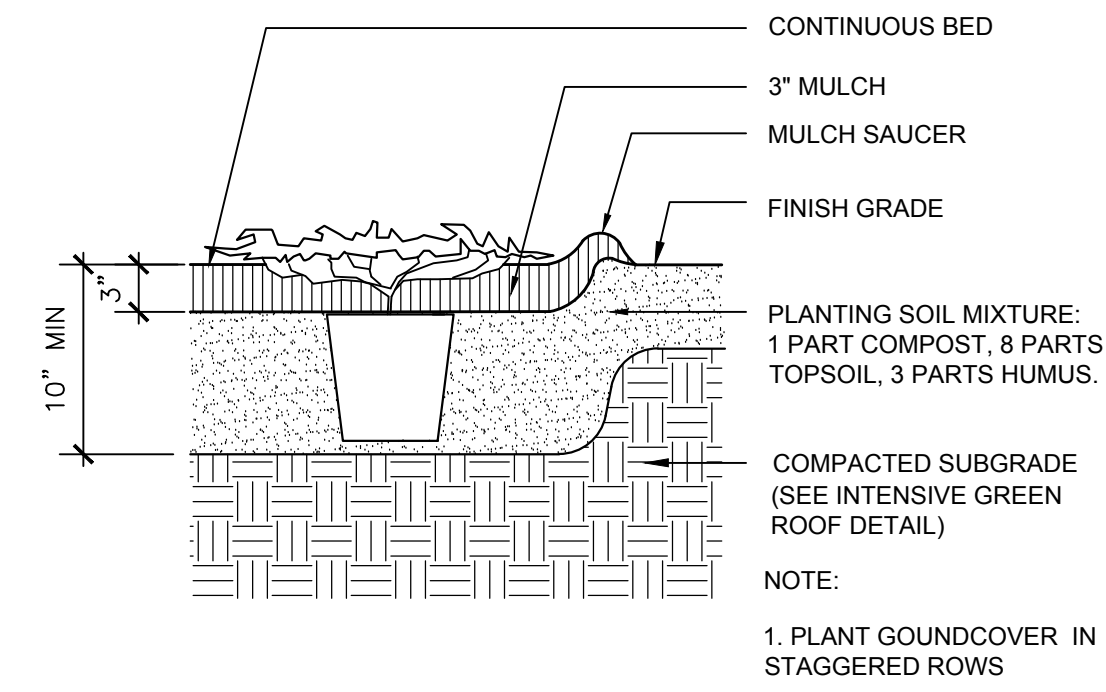

**3 GROUNDCOVER PLANTING**  
SCALE: N.T.S.

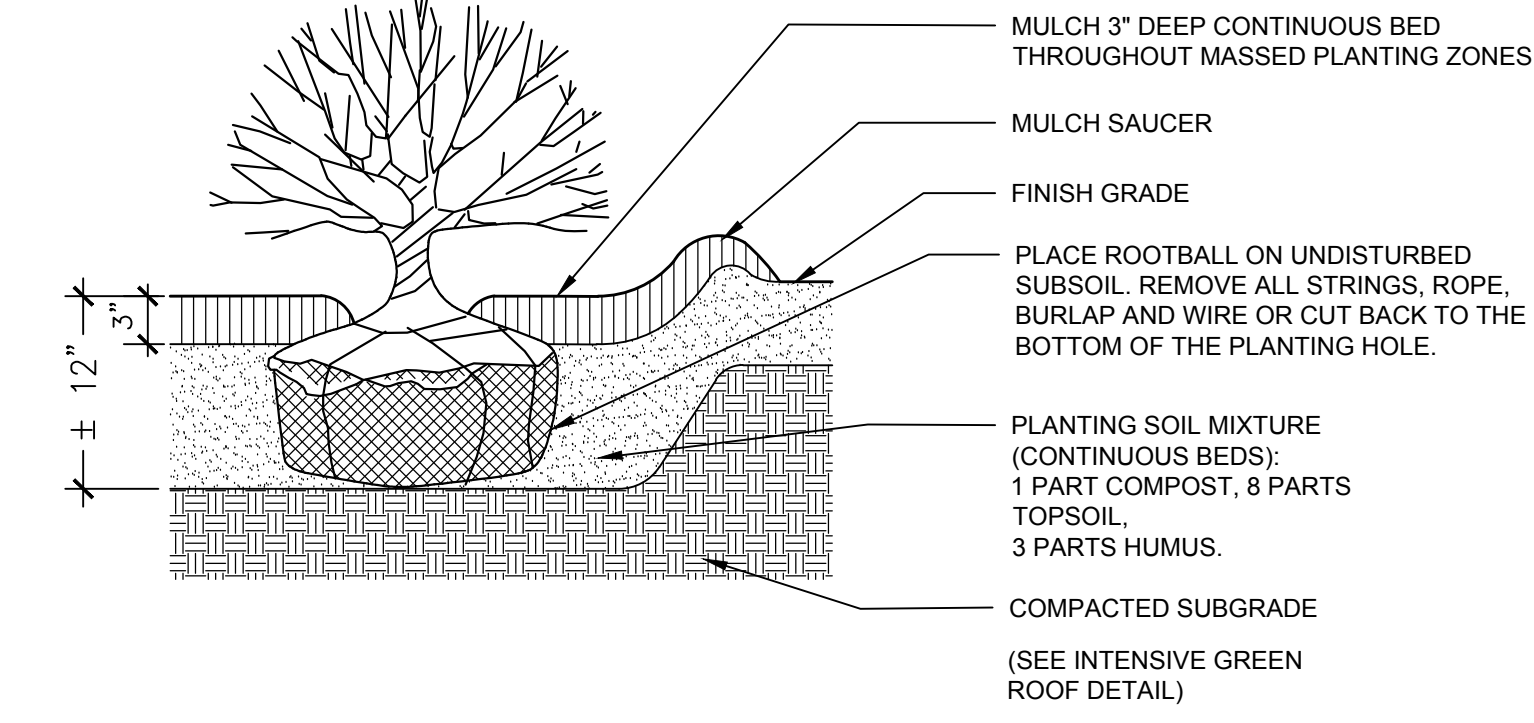

**2 SHRUB PLANTING**  
SCALE: N.T.S.

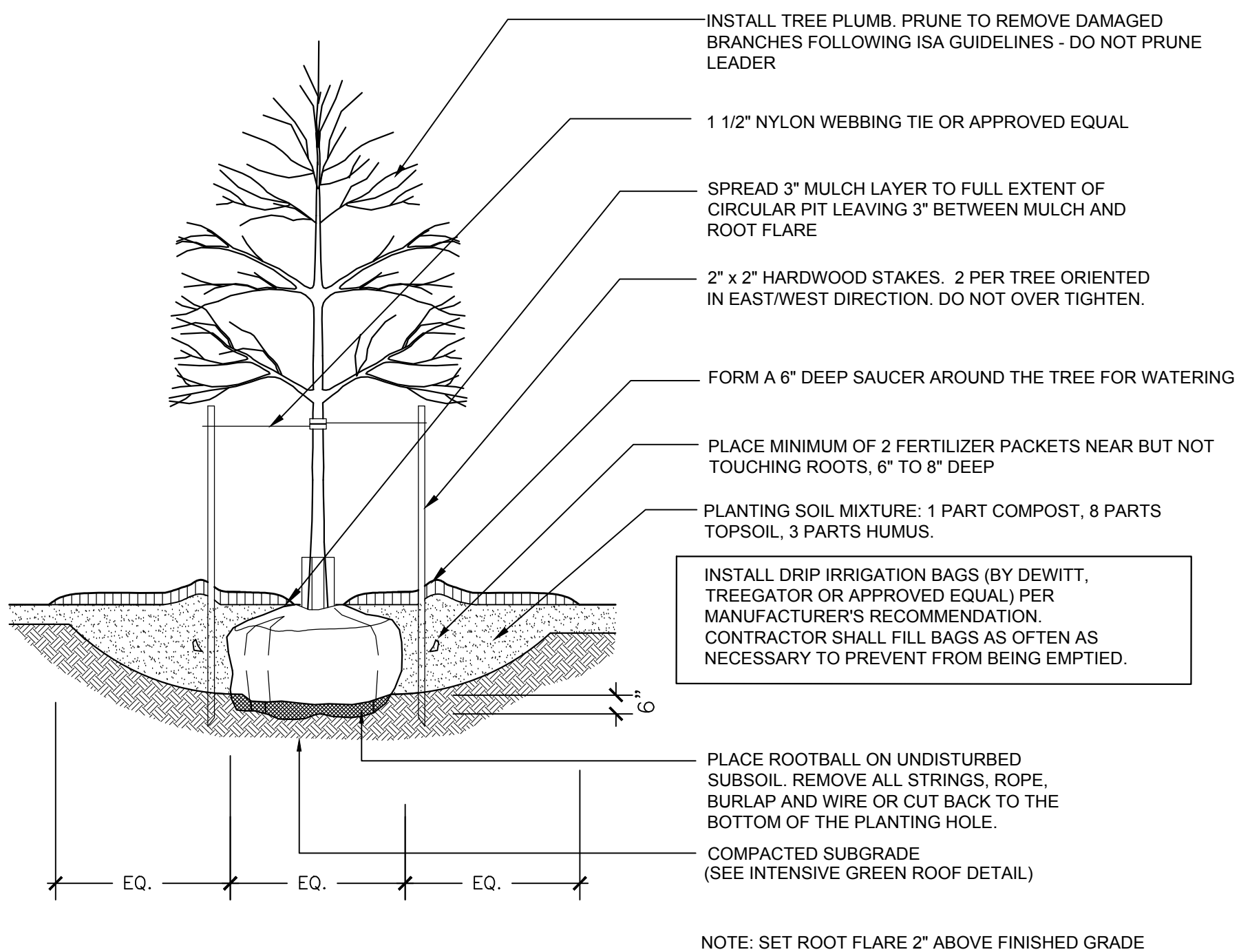

**1 TREE IN LANDSCAPE BED**  
SCALE: N.T.S.

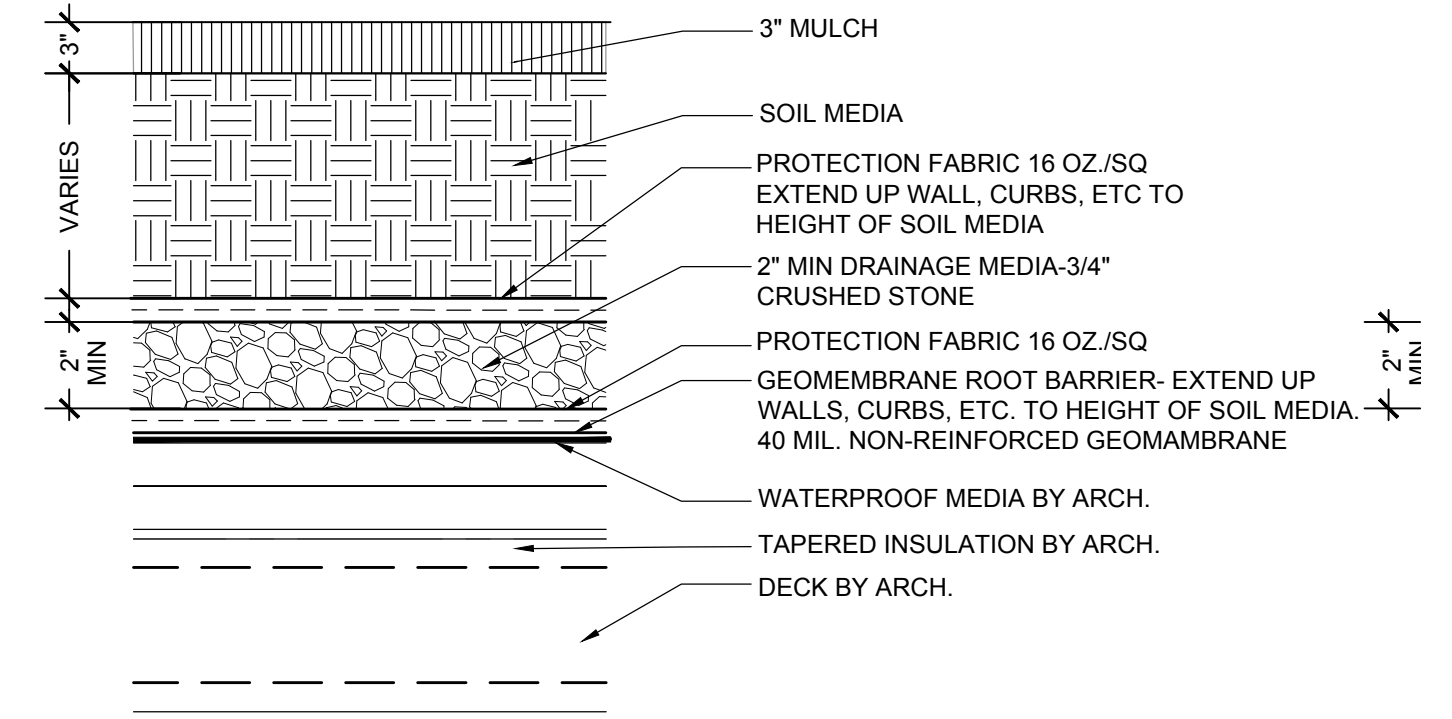

**6 INTENSIVE GREEN ROOF DETAIL**  
SCALE: N.T.S.

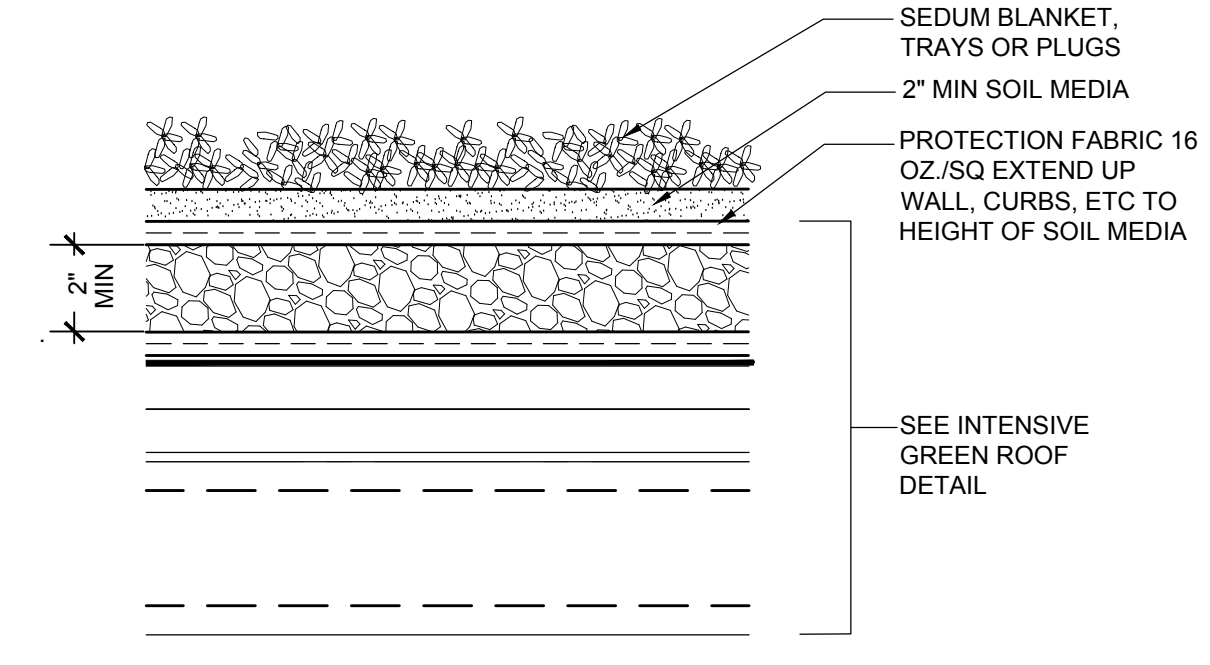

**5 SEEDLING PLANTING**  
SCALE: N.T.S.

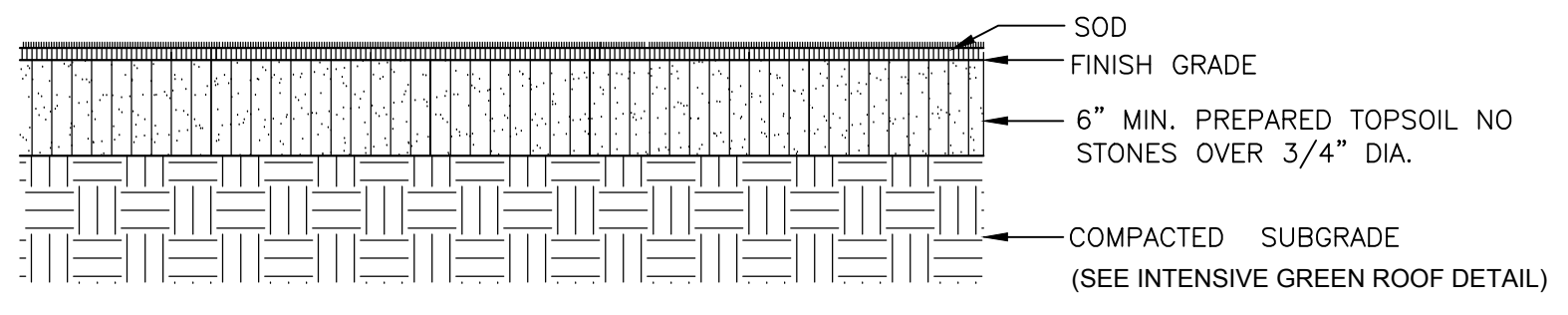

**4 SODDED LAWN**  
SCALE: N.T.S.

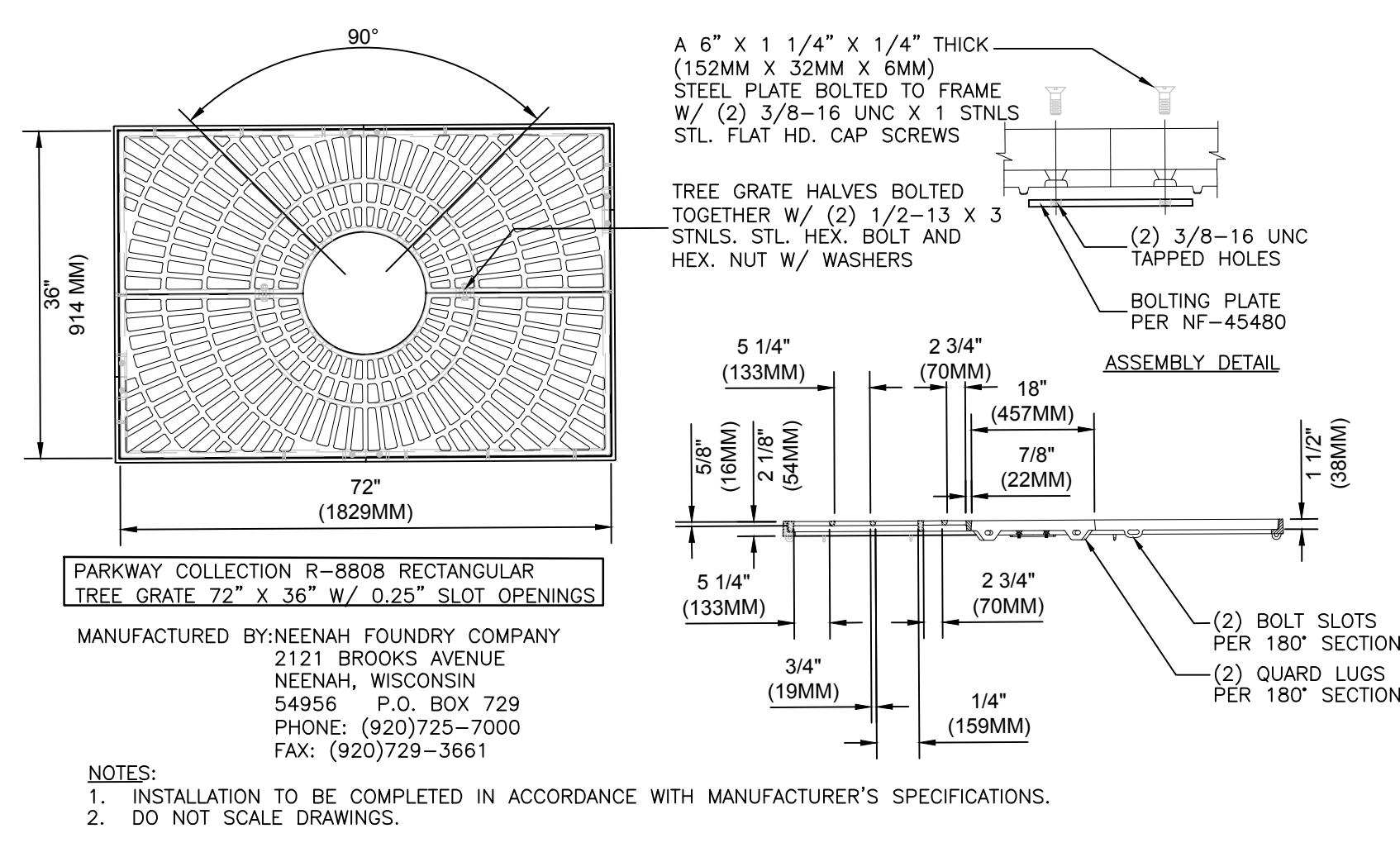

**7 TREE IN TREE GRATE**  
SCALE: N.T.S.

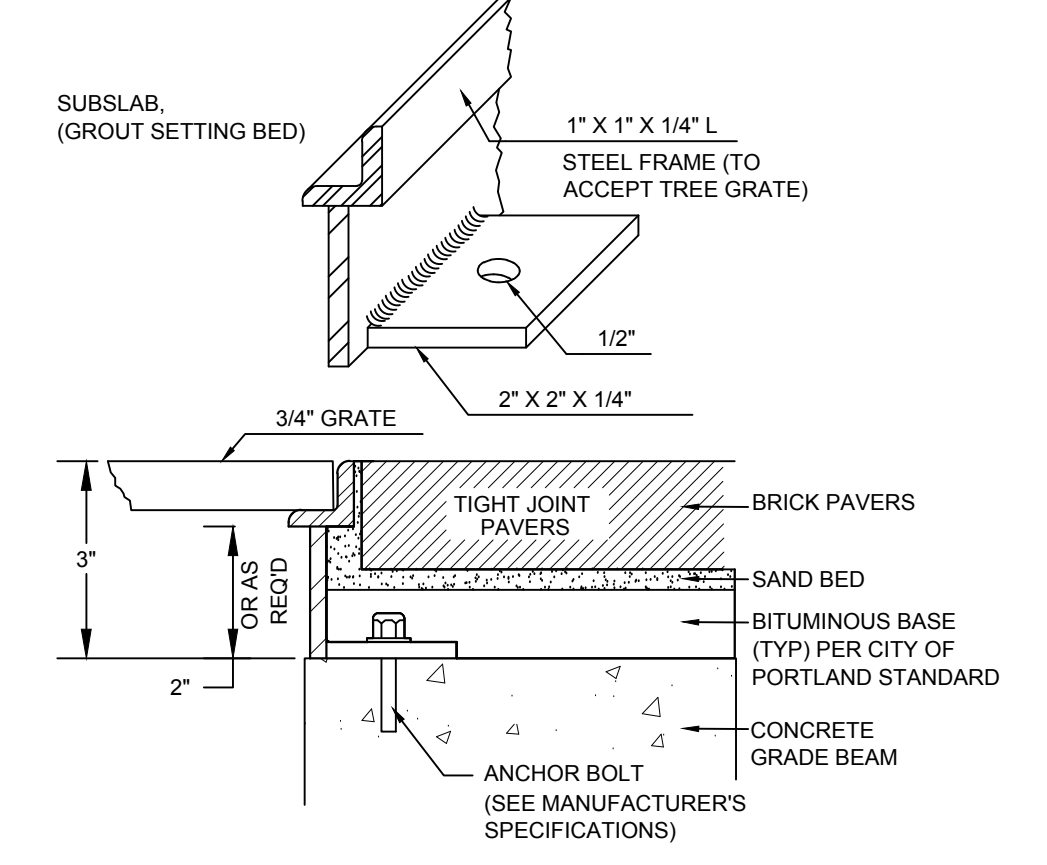

**7 TREE GRATE FRAME ANCHORING DETAIL**  
SCALE: N.T.S.

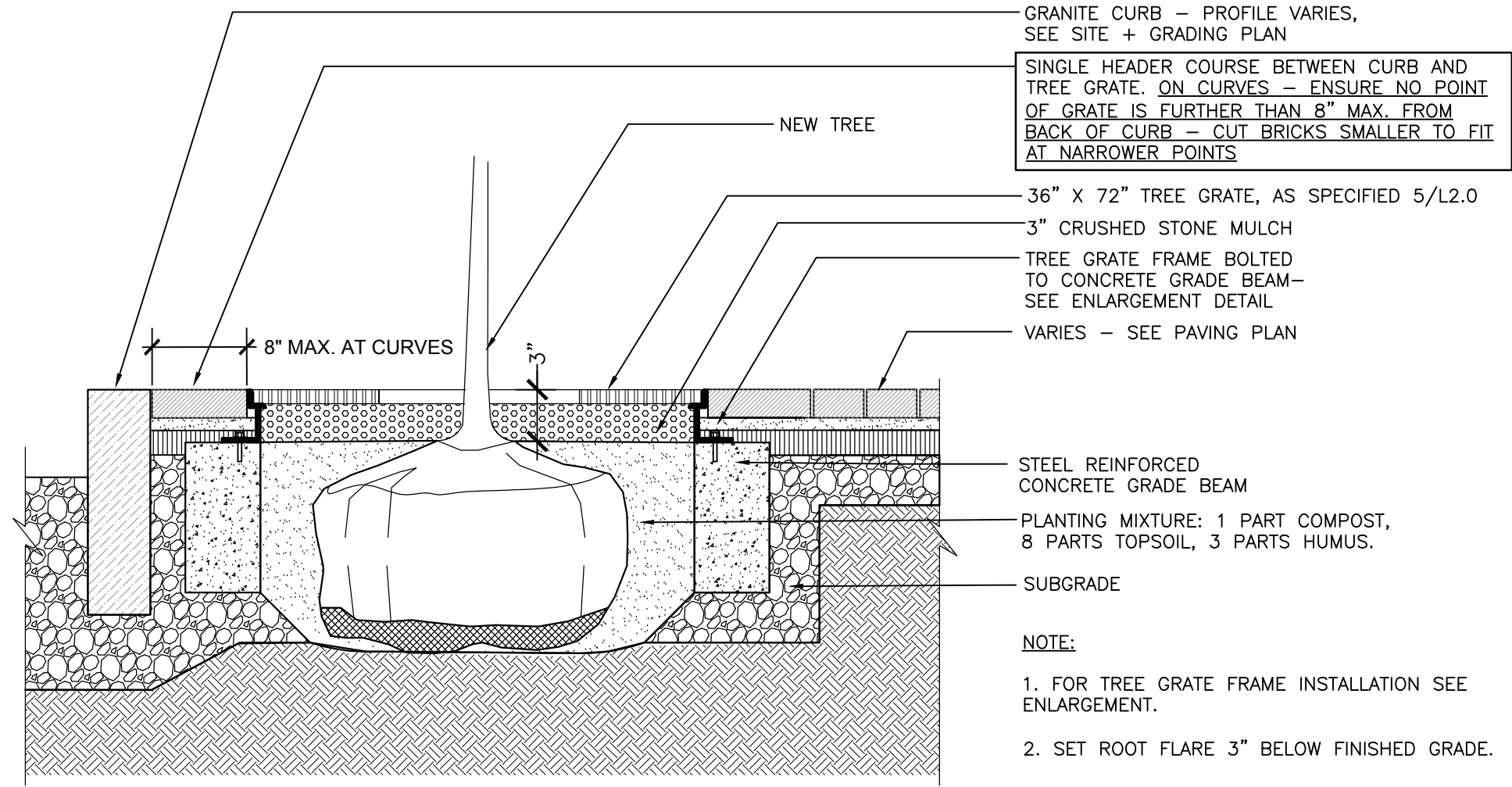

**7 TREE GRATE SECTION VIEW**  
SCALE: N.T.S.