

**3 DETAIL**  
SCALE: 1-1/2" = 1'-0"

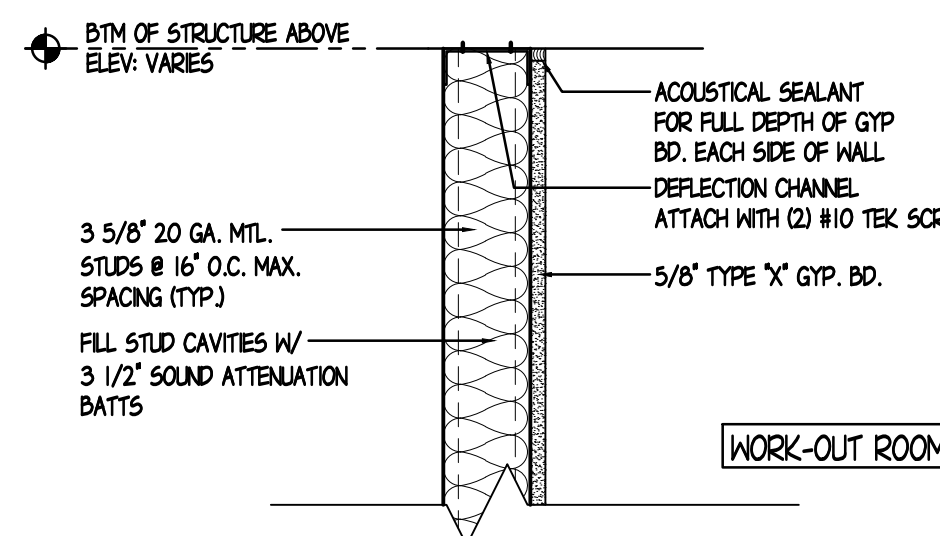

**6 DETAIL**  
SCALE: 1-1/2" = 1'-0"

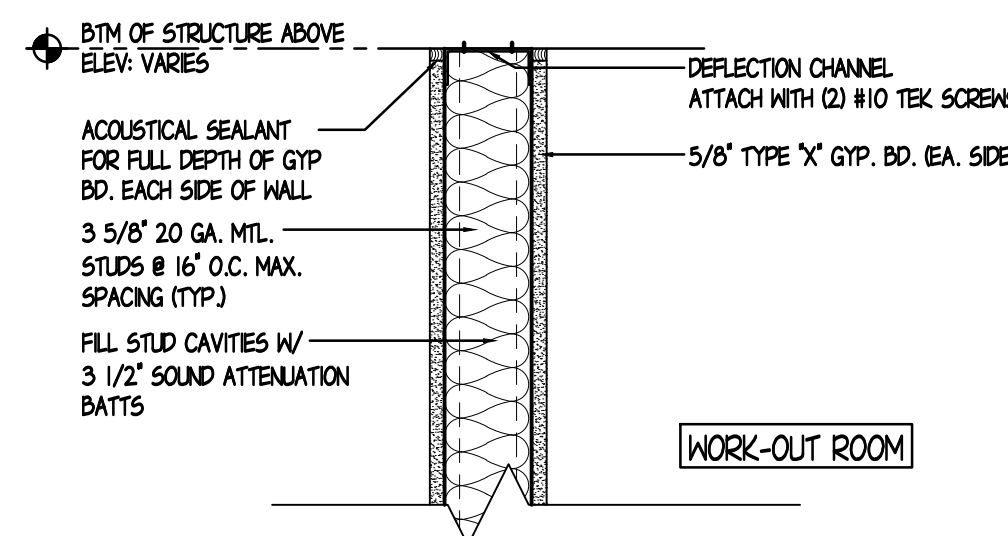

**9 DETAIL**  
SCALE: 1-1/2" = 1'-0"

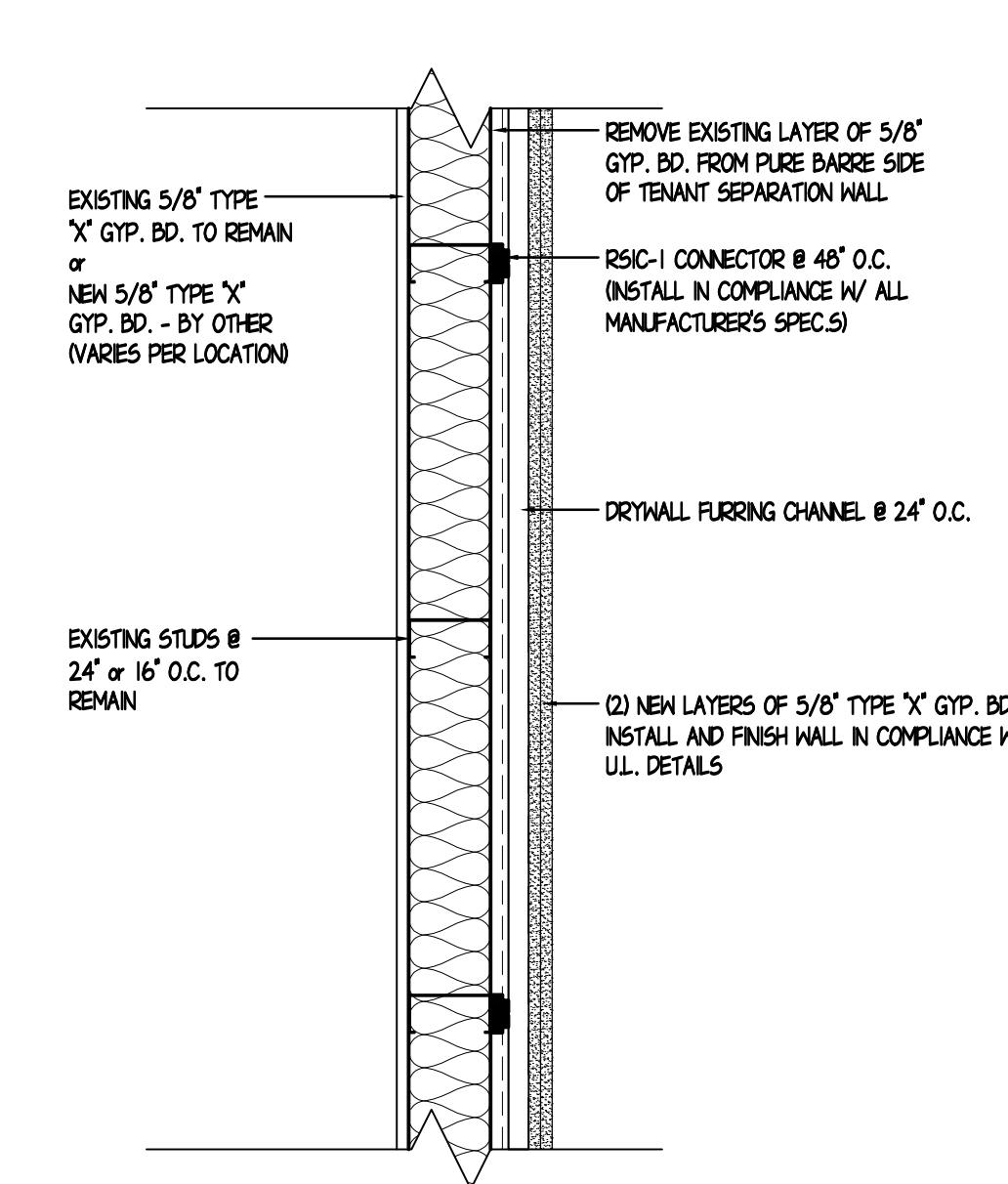

**18 ALT. "WORKOUT ROOM" DEMISING WALL DETAIL**  
SCALE: 1-1/2" = 1'-0"

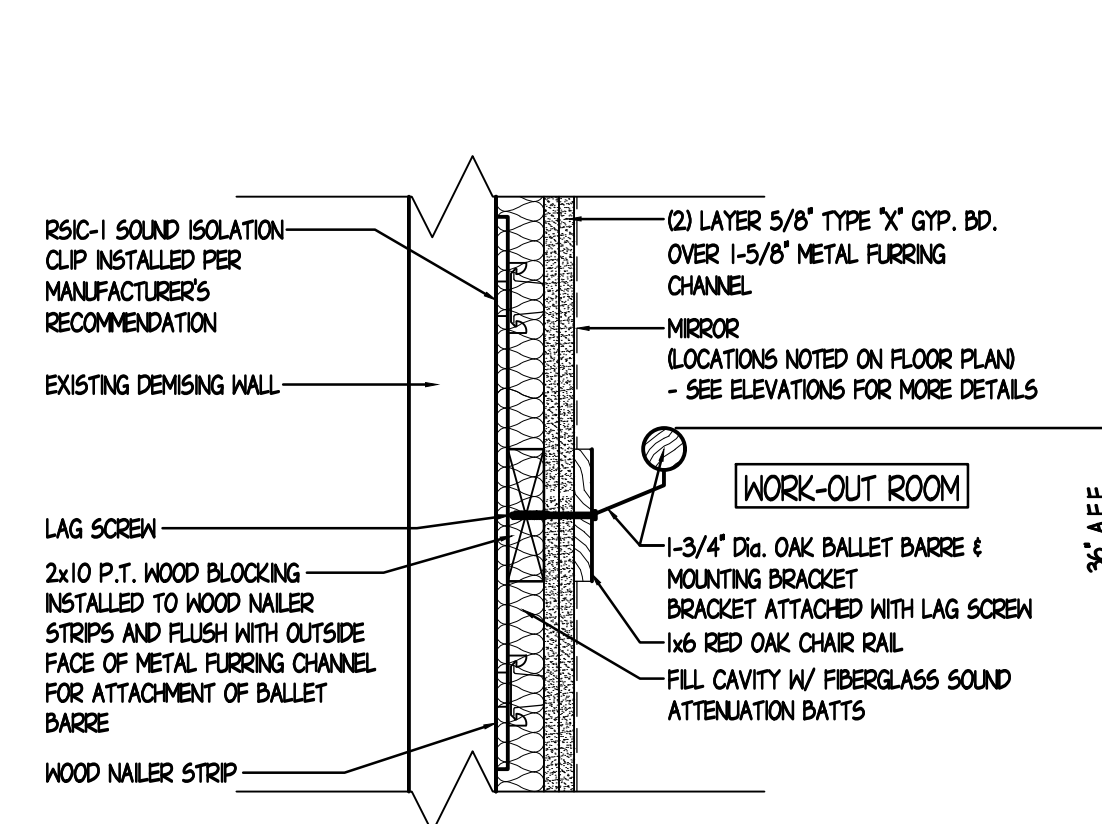

**21 ALT. "WORKOUT ROOM" DEMISING WALL DETAIL**  
SCALE: 1-1/2" = 1'-0"

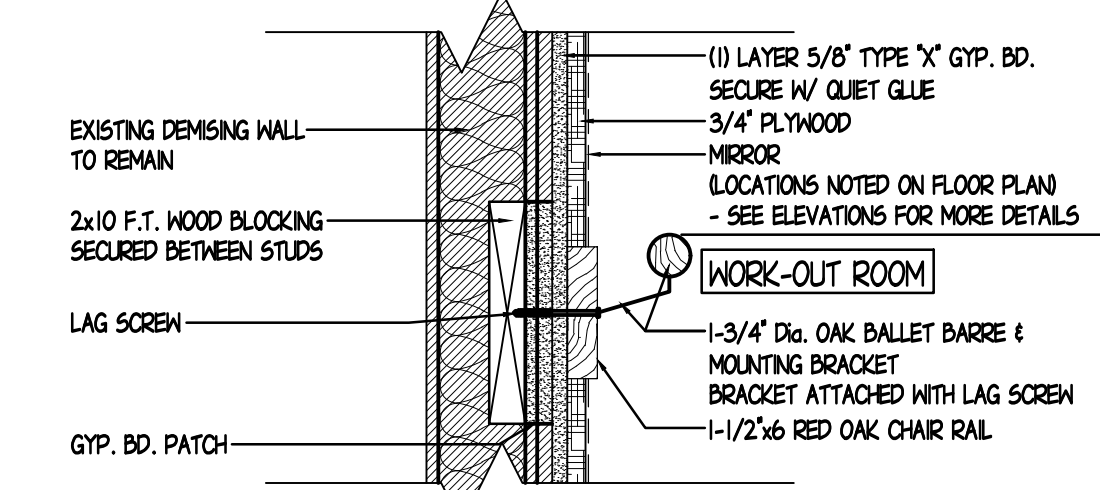

**2 DETAIL**  
SCALE: 1-1/2" = 1'-0"

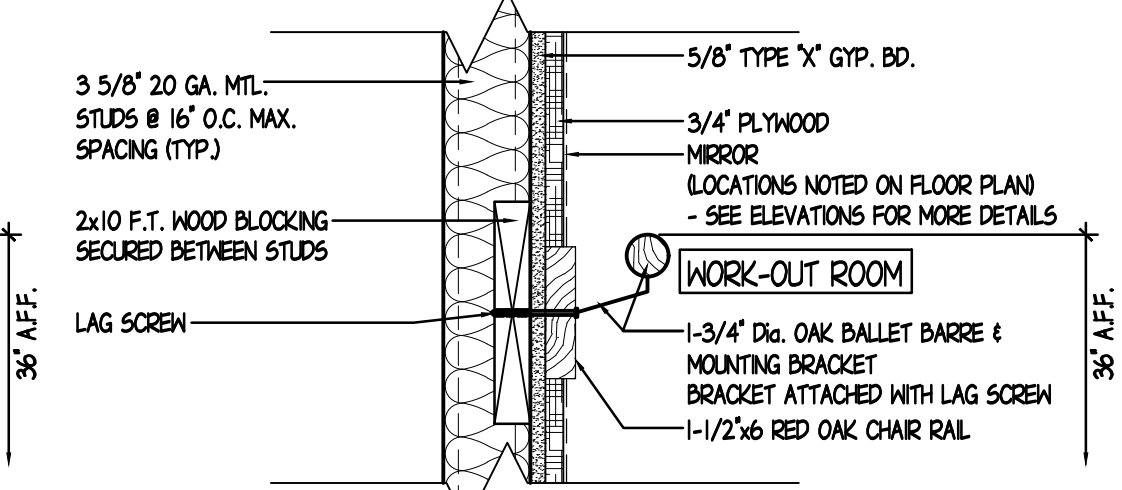

**5 DETAIL**  
SCALE: 1-1/2" = 1'-0"

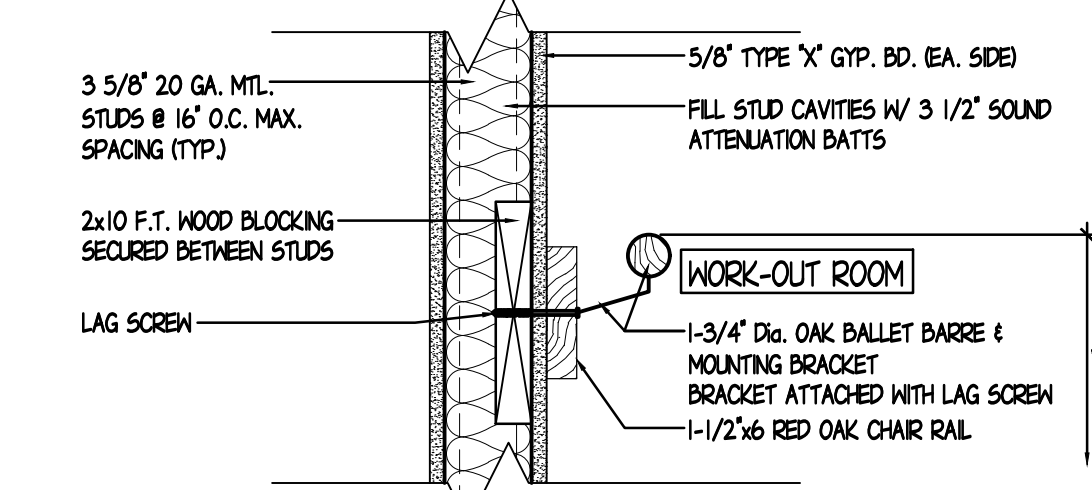

**8 DETAIL**  
SCALE: 1-1/2" = 1'-0"

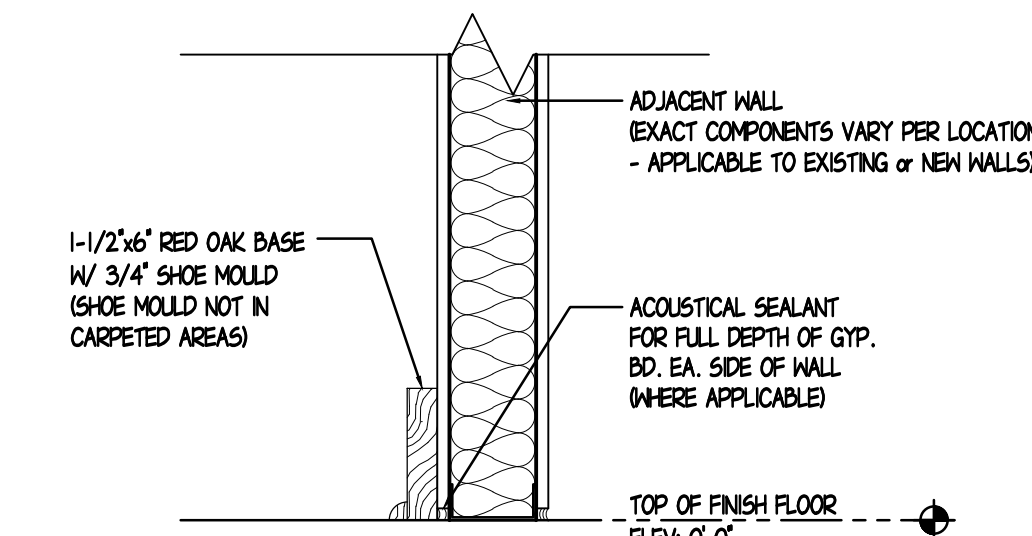

**10 DETAIL**  
SCALE: 1-1/2" = 1'-0"

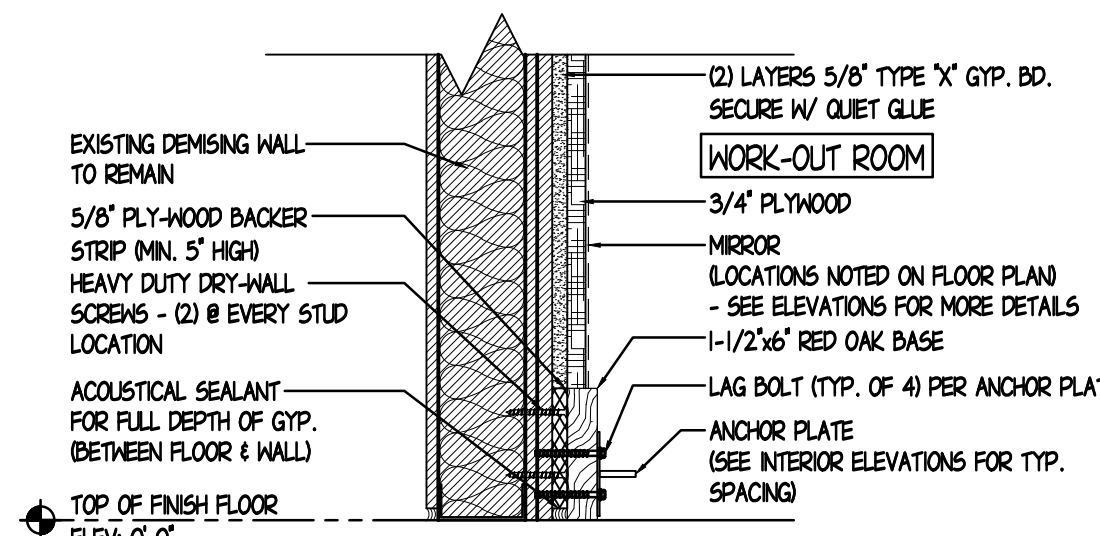

**1 DETAIL**  
SCALE: 1-1/2" = 1'-0"

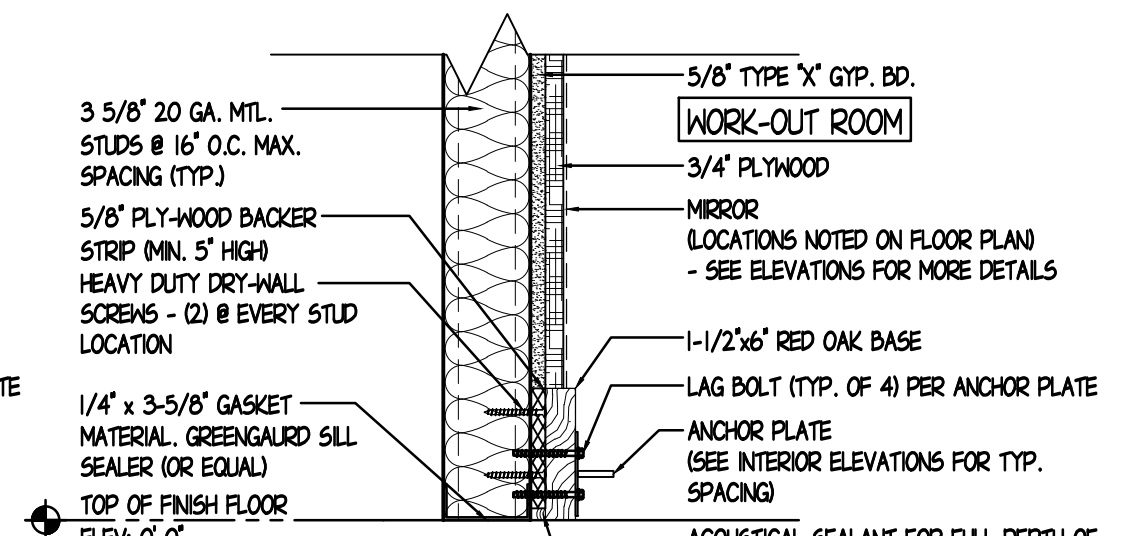

**4 DETAIL**  
SCALE: 1-1/2" = 1'-0"

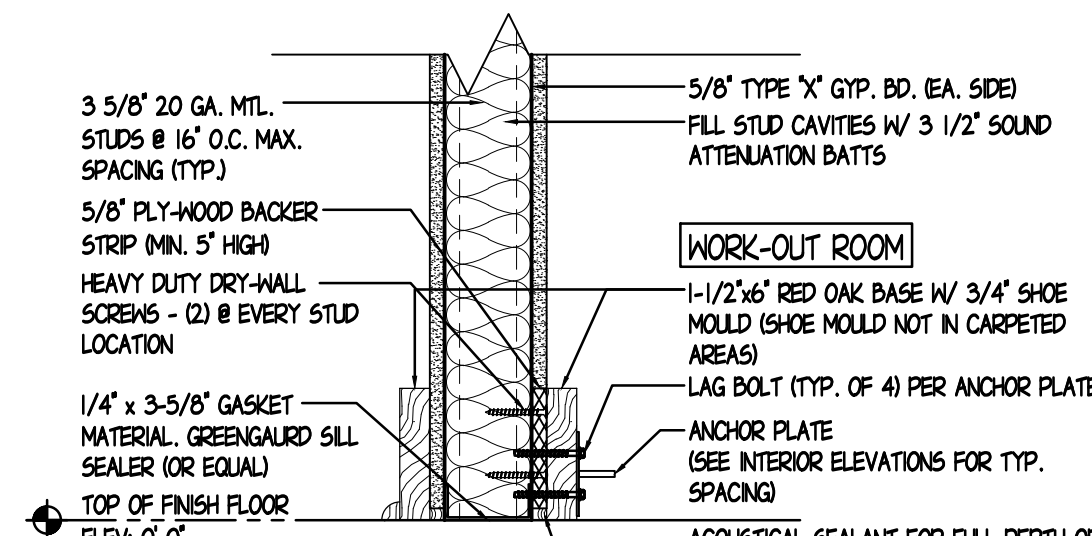

**7 DETAIL**  
SCALE: 1-1/2" = 1'-0"

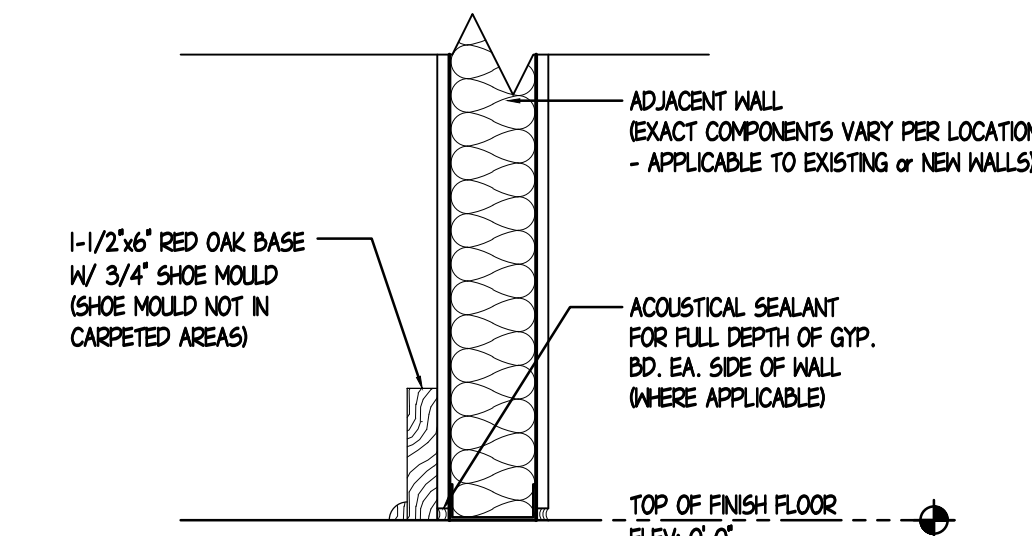

**18 ALT. "WORKOUT ROOM" DEMISING WALL DETAIL**  
SCALE: 1-1/2" = 1'-0"

**NOTE TO FRAMER:**  
• NO OBJECTS, WIRES, MEANS OF CONNECTION ETC. SHALL BE MOUNTED VIA THE BOTTOM CHORD OF BLDG TRUSSES; ALL SUCH CONNECTIONS SHALL BE ATTACHED TO THE TOP CHORD.

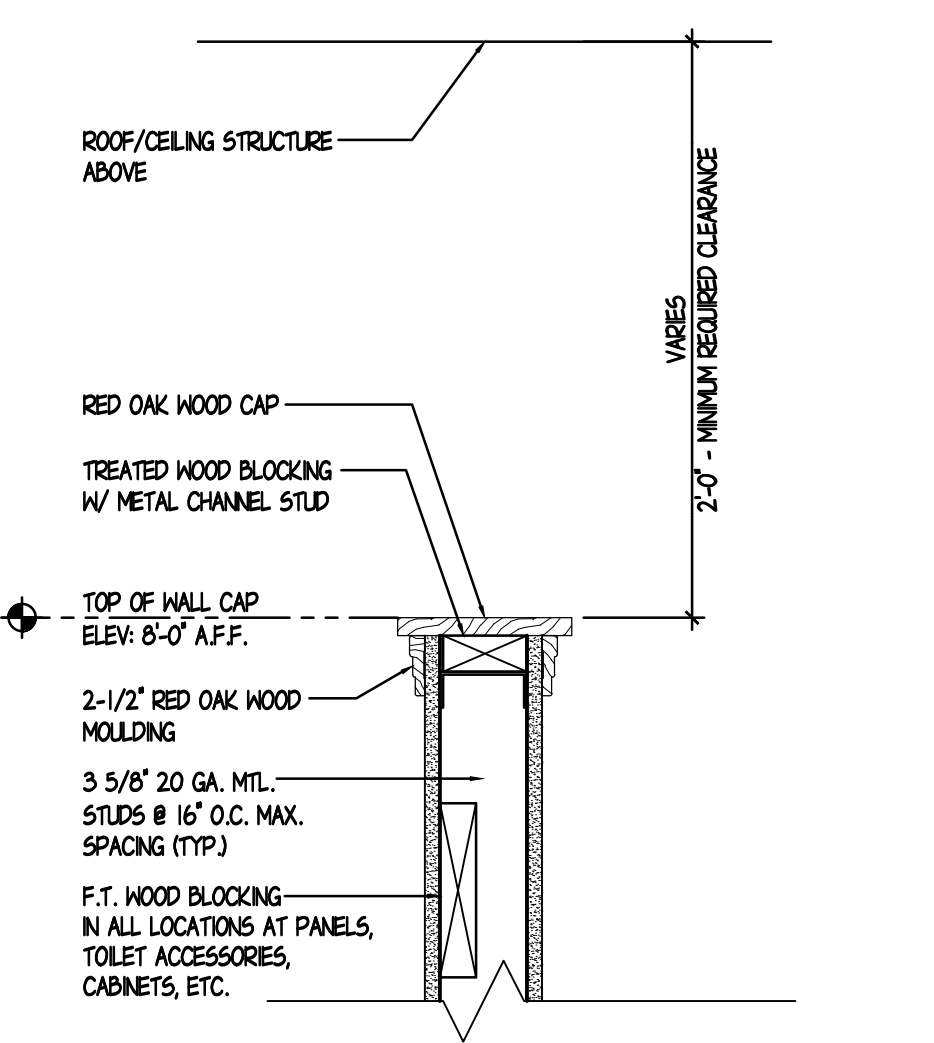

**11 WALL CAP DETAIL**  
SCALE: 1-1/2" = 1'-0"

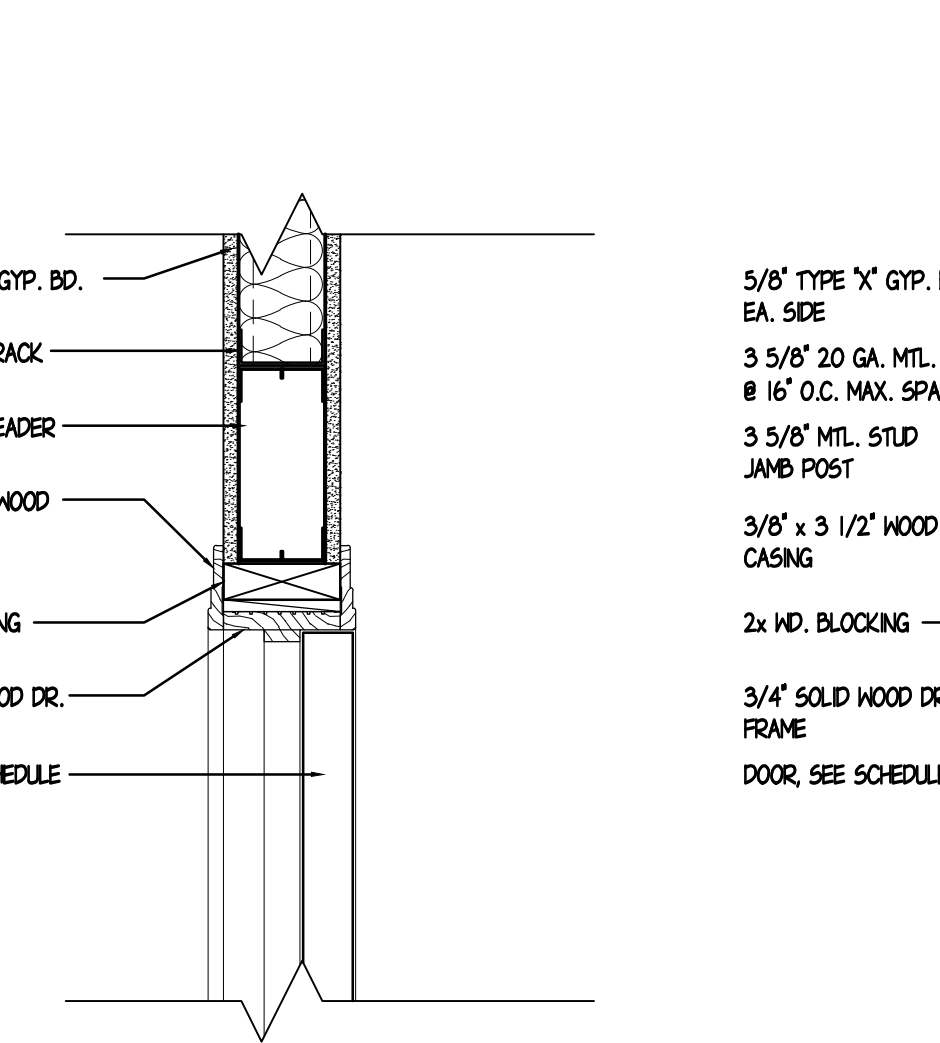

**12 TYP. HEAD DETAIL**  
SCALE: 1-1/2" = 1'-0"

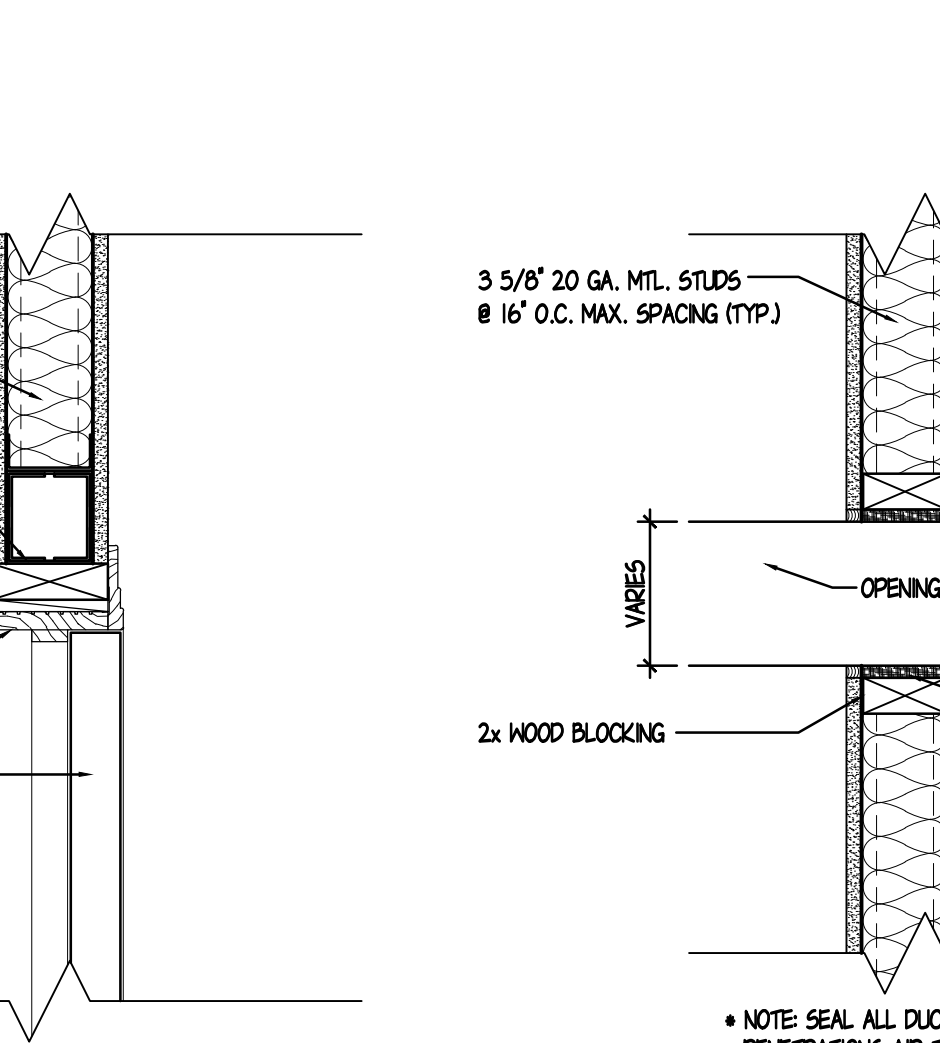

**13 TYP. JAMB DETAIL**  
SCALE: 1-1/2" = 1'-0"

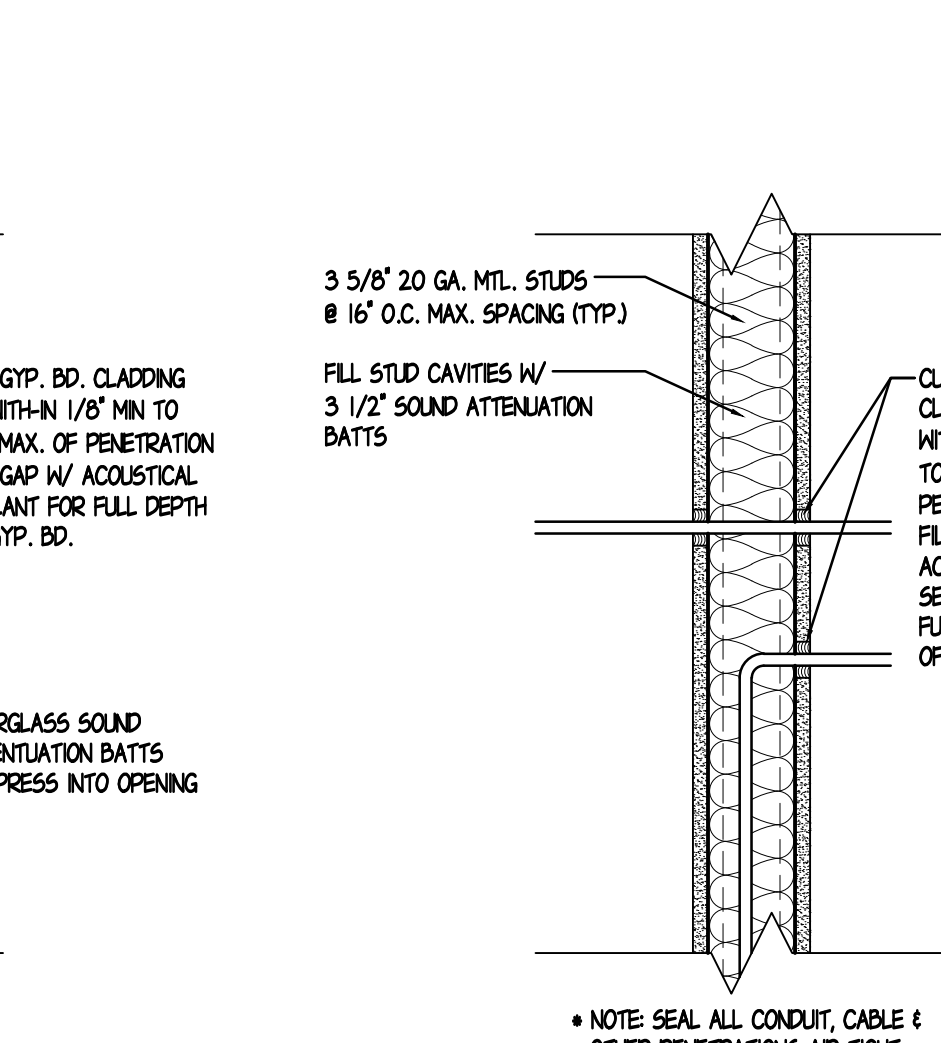

**14 TYP. PENETRATION DETAIL**  
SCALE: 1-1/2" = 1'-0"

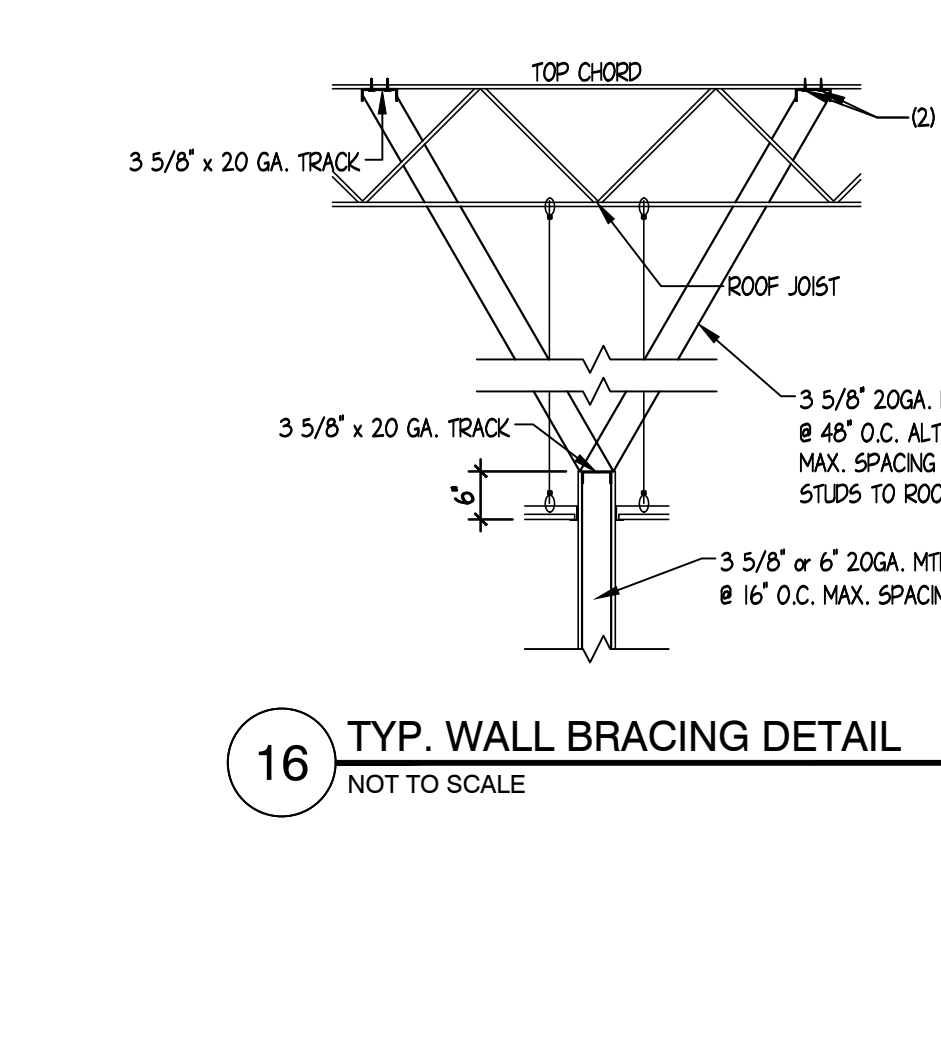

**15 TYP. PENETRATION DETAIL**  
SCALE: 1-1/2" = 1'-0"

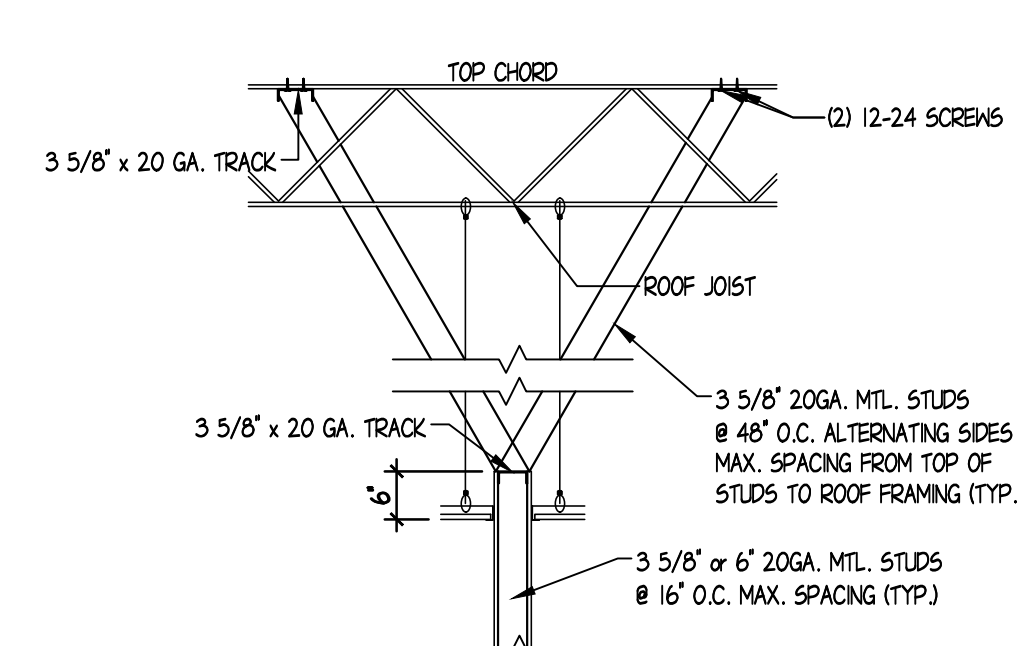

**16 TYP. WALL BRACING DETAIL**  
NOT TO SCALE

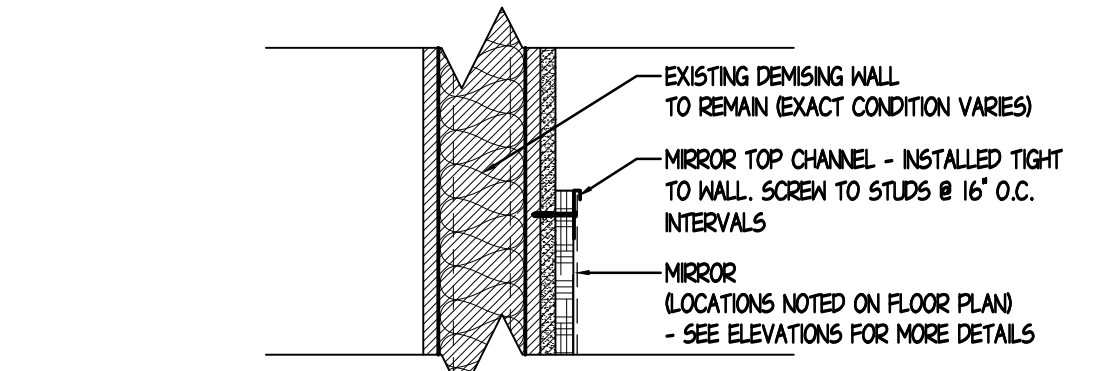

**19 TYP. TOP MIRROR BRACKET DETAIL**  
SCALE: 1-1/2" = 1'-0"



**20 TYP. BOTTOM MIRROR BRACKET DETAIL**  
SCALE: 1-1/2" = 1'-0"

CONTRACTOR SHALL VERIFY PROPER MOISTURE BARRIER EXISTS BETWEEN ALL MASONRY 1/4" CONCRETE WALLS & ADJACENT NEW METAL FRAMING; IF BARRIER IS NOT EXISTING, PURE BARRE CONTRACTOR SHALL INSTALL MOISTURE BARRIER. CONSULT PURE BARRE CONSTRUCTION DEPARTMENT FOR DESIRED PRODUCT SPECIFICATION.

**SPECIAL NOTE:**  
GREEN GLUE SHALL BE USED BETWEEN THE FOLLOWING CONNECTIONS: (REF DETAILS 1, 4, & 7 ON SHEET A-02)  
ANCHOR PLATE TO BASE BOARD, BASE BOARD TO PLYWOOD, AND PLYWOOD TO GYP. BD.

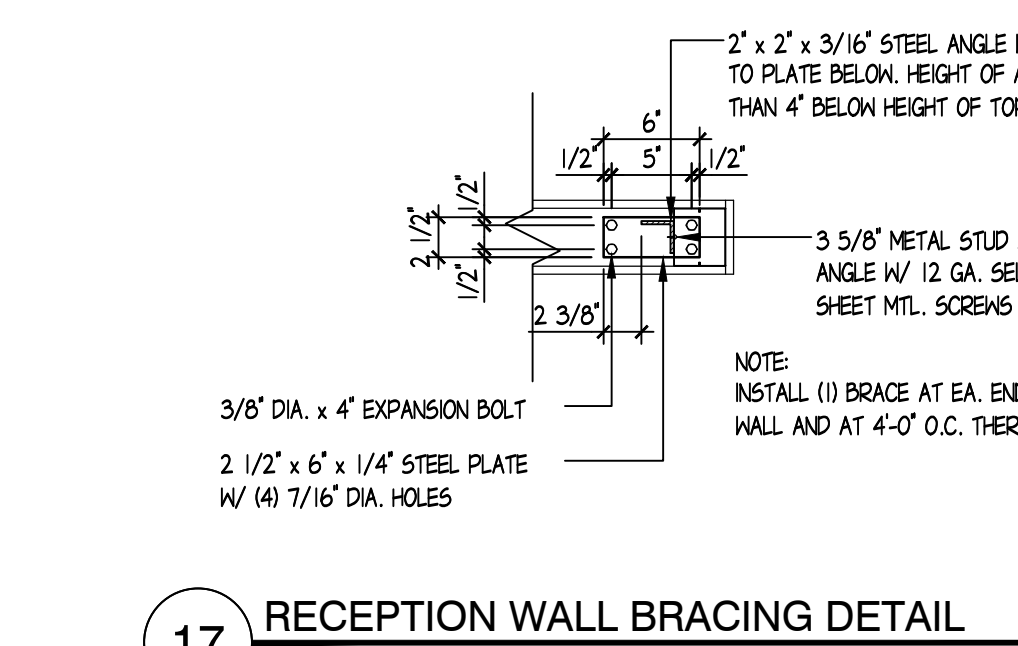

**17 RECEPTION WALL BRACING DETAIL**  
SCALE: 1" = 1'-0"



**GERALD P. NOE ARCHITECT**  
MAINE REGISTRATION NO. 4035

399 LUCERNE DRIVE  
SPARTANBURG, SC 29302  
P: 864.583.2215 F: 864.583.2265  
mail@gpnarcht.com

CHECKED BY: GPN  
DRAWN BY: JMF, DKH

THIS DRAWING IS AN INSTRUMENT OF SERVICE AND SOLE PROPERTY OF THE ARCHITECT, AND SHALL NOT BE USED IN ANY WAY, WHATSOEVER, WITHOUT THE WRITTEN PERMISSION OF THE ARCHITECT. IT SHALL BE RETURNED TO THE ARCHITECT UPON DEMAND.  
COPYRIGHT 2017  
ALL RIGHTS RESERVED



DATE: 2017-09-21

REVISIONS:

NO.	DATE	DESCRIPTION	BY

CLIENT NAME:  
**pure barre**  
lift • tone • burn  
J+J FIT, LLC  
OWNER: JAMIE CALENDA  
18 PARKER AVENUE  
WARREN, RI 02885  
EMAIL: JCALENDA@PUREBARRE.COM

PROJECT NAME:  
**pure barre**  
lift • tone • burn  
**INTERIOR UP-FIT**  
TWO PORTLAND SQUARE  
477 FORT STREET - SUITE 128  
PORTLAND, MAINE 04101

SHEET TITLE:

**WALL DETAILS**

PROJECT NUMBER: 17-A094

DATE: 2017-09-21

SHEET NO.

THE ARCHITECT SHALL NOT BE RESPONSIBLE FOR ACTUAL CONDITIONS, CONSTRUCTION AND/OR USE THEREOF. THIS DRAWING IS TO CONVEY DESIGN INTENTIONS AND/OR CODE COMPLIANCE ONLY. USE OF THESE DRAWINGS IMPLIES AGREEMENT WITH THESE CONDITIONS. THE CONTRACTOR IS TO VERIFY ALL DIMENSIONS.