

DATE: 2017-09-21

REVISIONS:

NO.	DATE	DESCRIPTION	BY
-----	------	-------------	----

CLIENT NAME:



J+J FIT, LLC
OWNER: JAMIE CALENDA
118 PARKER AVENUE
WARREN, RI 02885
EMAIL: JCALENDA@PUREBARRE.COM

PROJECT NAME:



INTERIOR UP-FIT

TWO PORTLAND SQUARE
477 FORE STREET - SUITE 128
PORTLAND, MAINE 04101

SHEET TITLE:

**TYPICAL
DETAILS &
SECTIONS**

PROJECT NUMBER: 17-A094

DATE: 2017-09-21

SHEET NO.

A-1.1

SHEET 1.1 OF 7

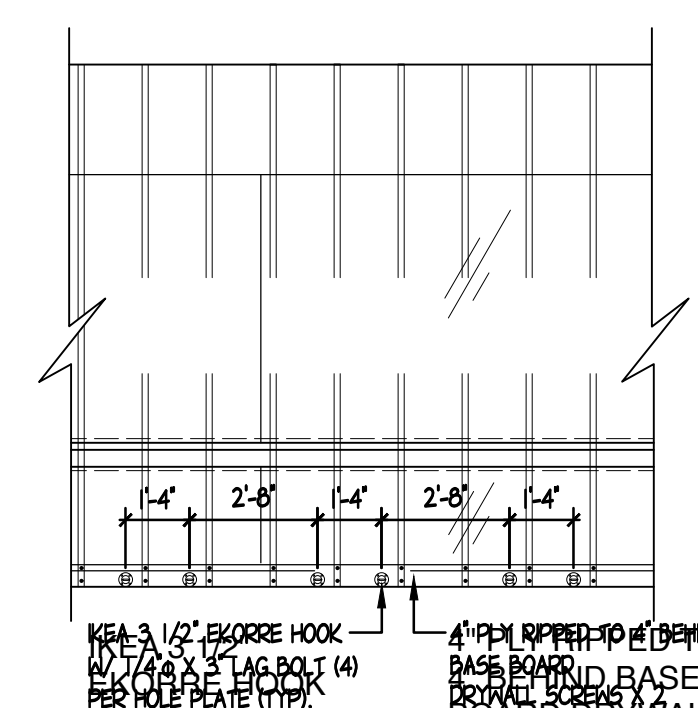
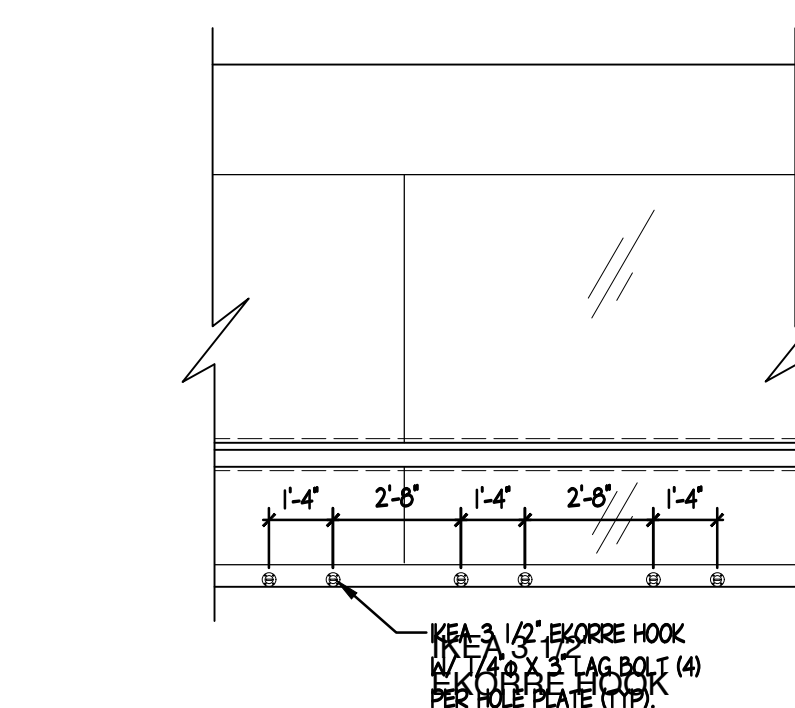
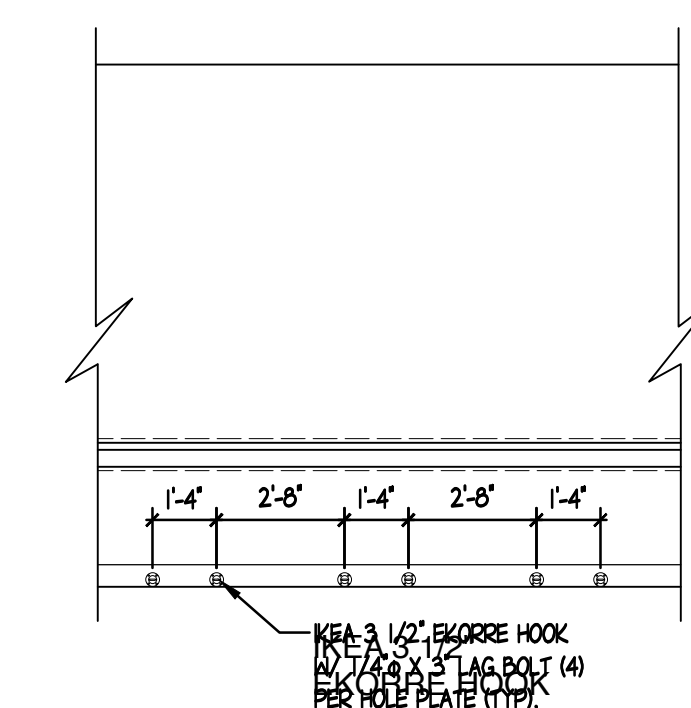
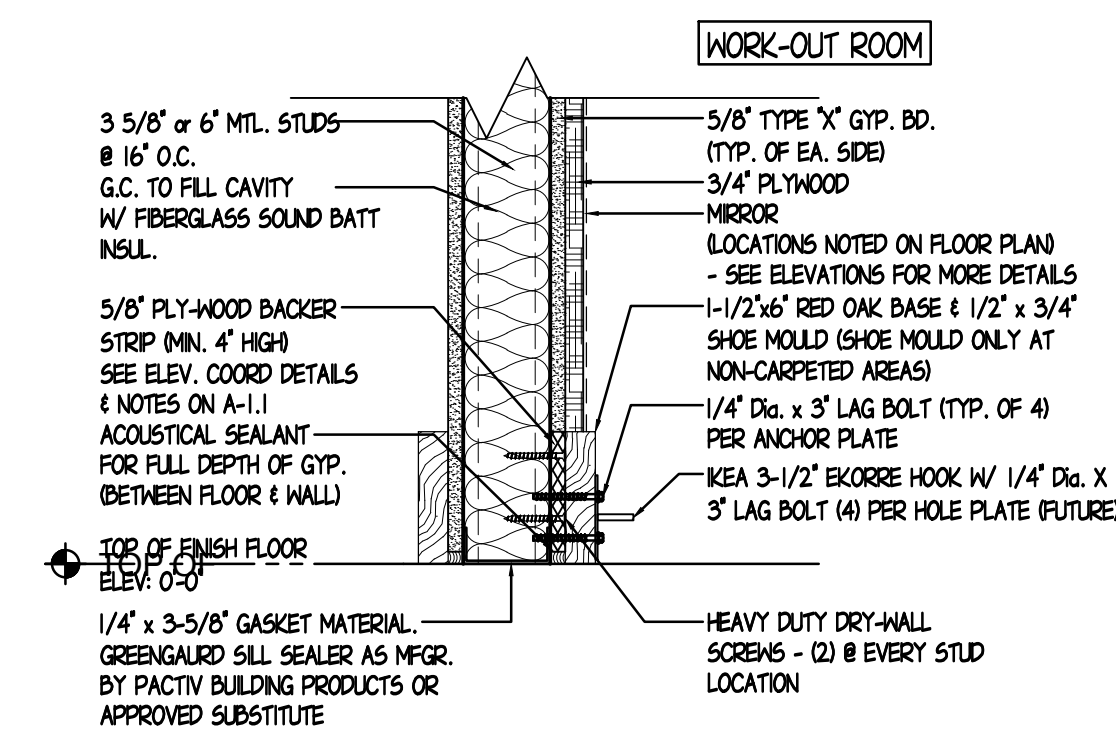
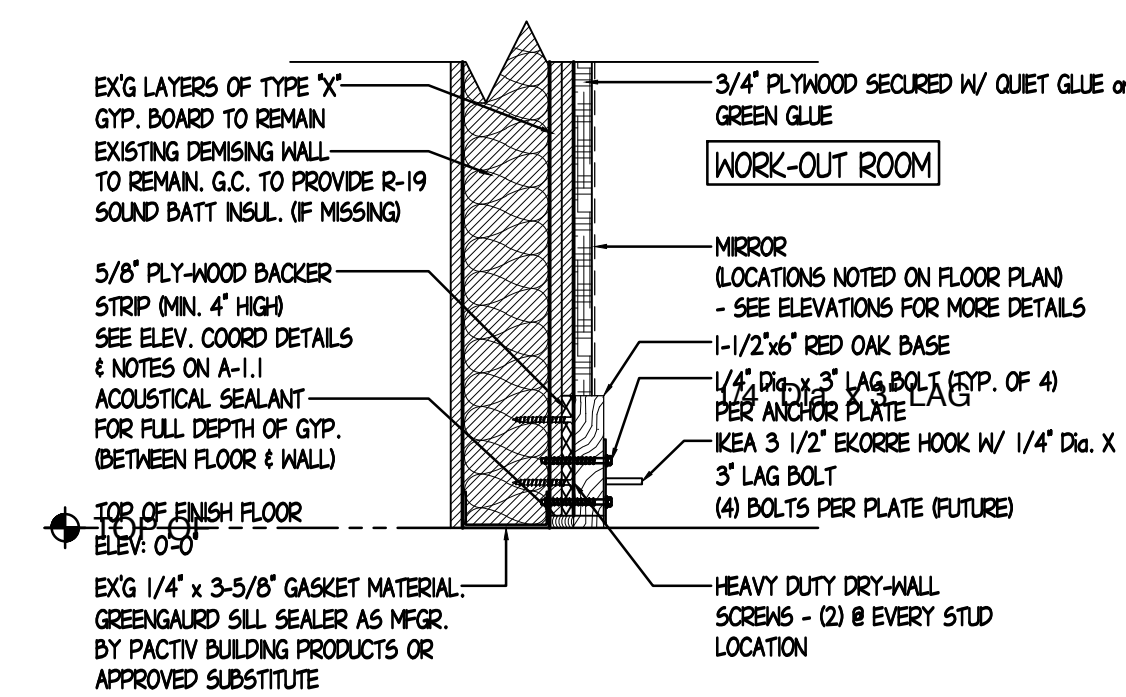
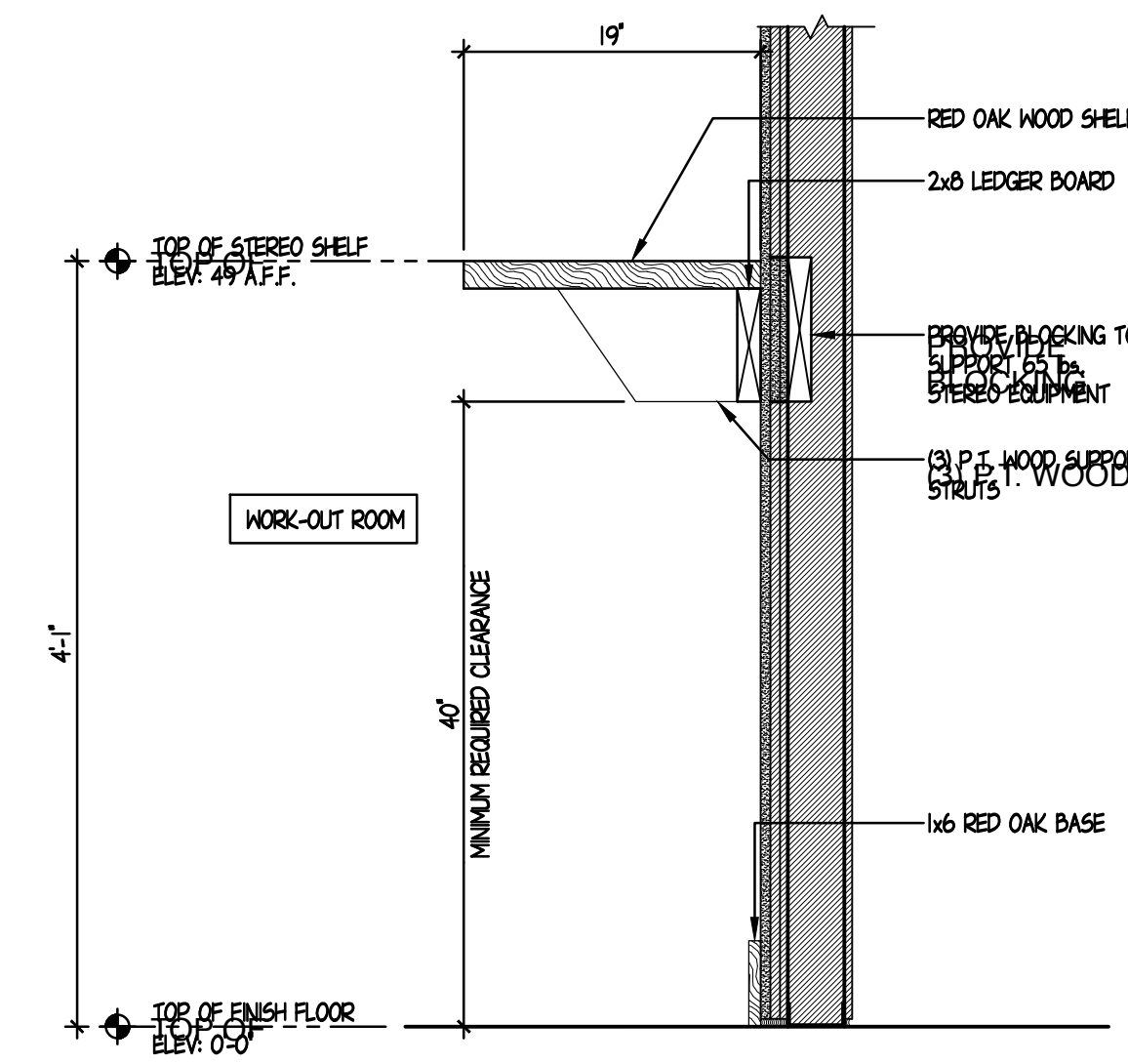
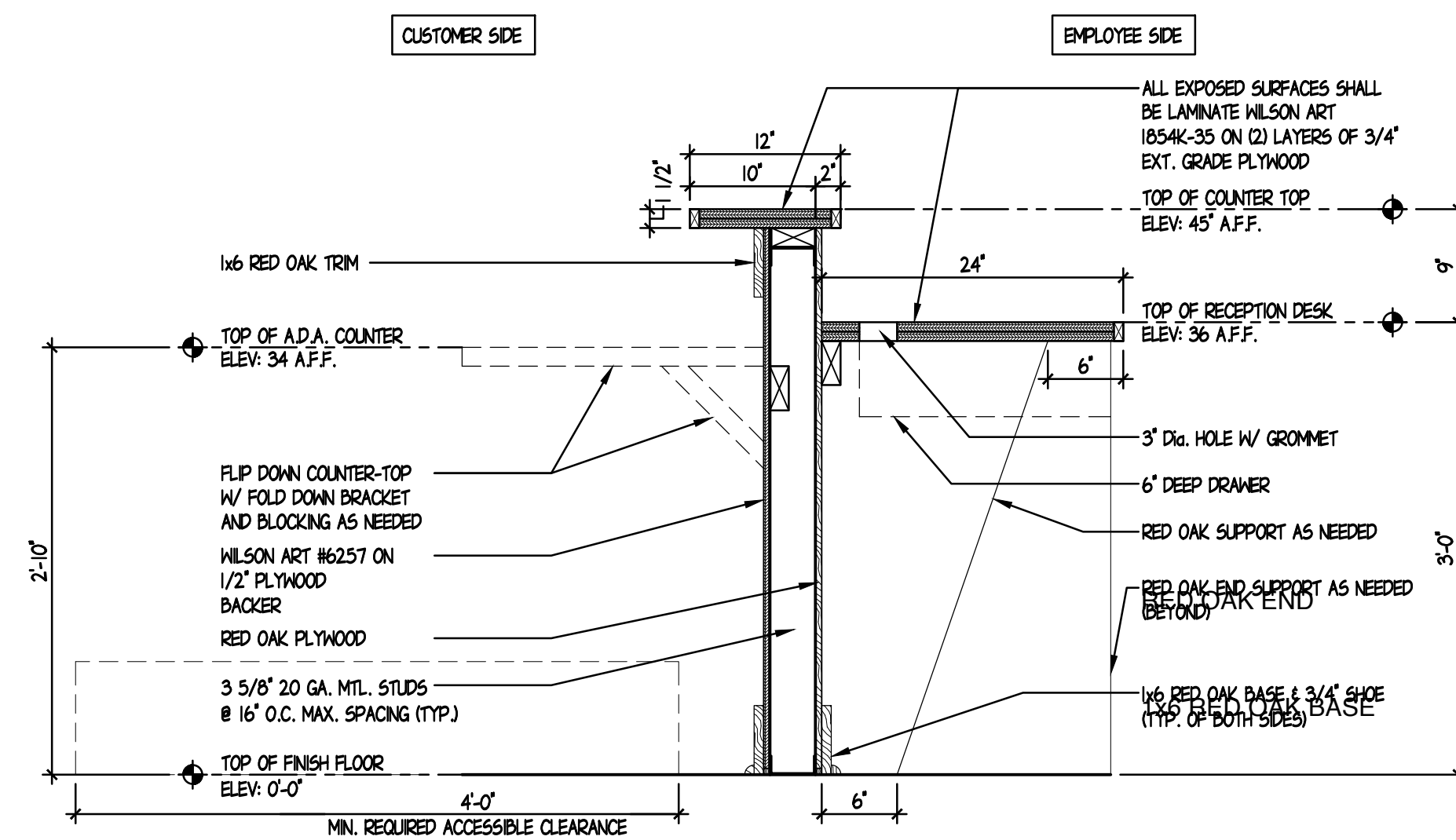

THE ARCHITECT SHALL NOT BE RESPONSIBLE FOR ACTUAL CONDITIONS, CONSTRUCTION AND/OR USE THEREOF. THIS DRAWING IS TO CONVEY DESIGN INTENTIONS AND/OR CODE COMPLIANCE ONLY. USE OF THESE DRAWINGS IMPLIES AGREEMENT WITH THESE CONDITIONS. THE CONTRACTOR IS TO VERIFY ALL DIMENSIONS.