

D1 ELEVATION @ PANTRY 503
SCALE: 1/2" = 1'-0"

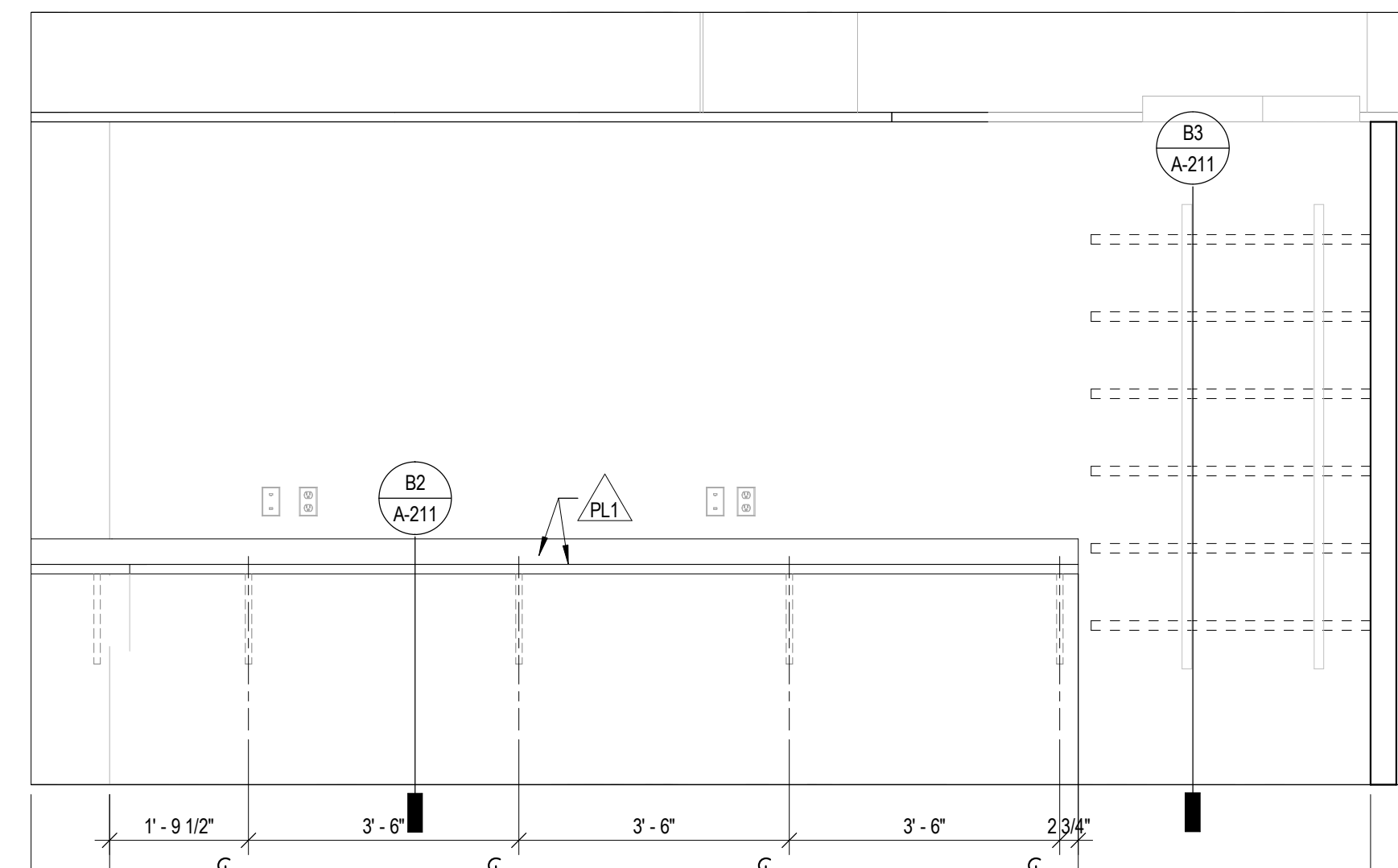

D2 ELEVATION @ IT ROOM 509
SCALE: 1/2" = 1'-0"

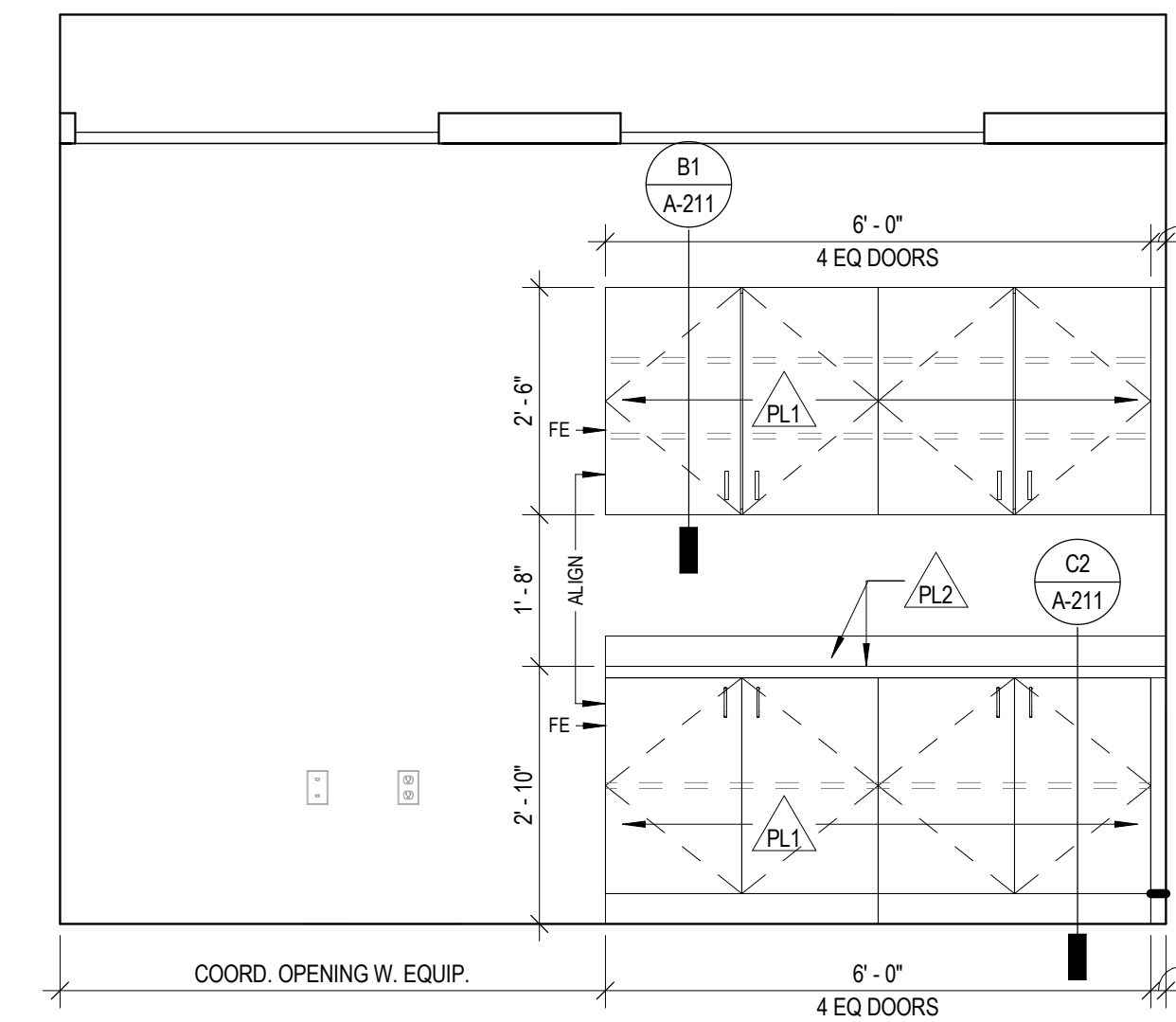

D3 ELEVATION @ COPY/WORK 506
SCALE: 1/2" = 1'-0"

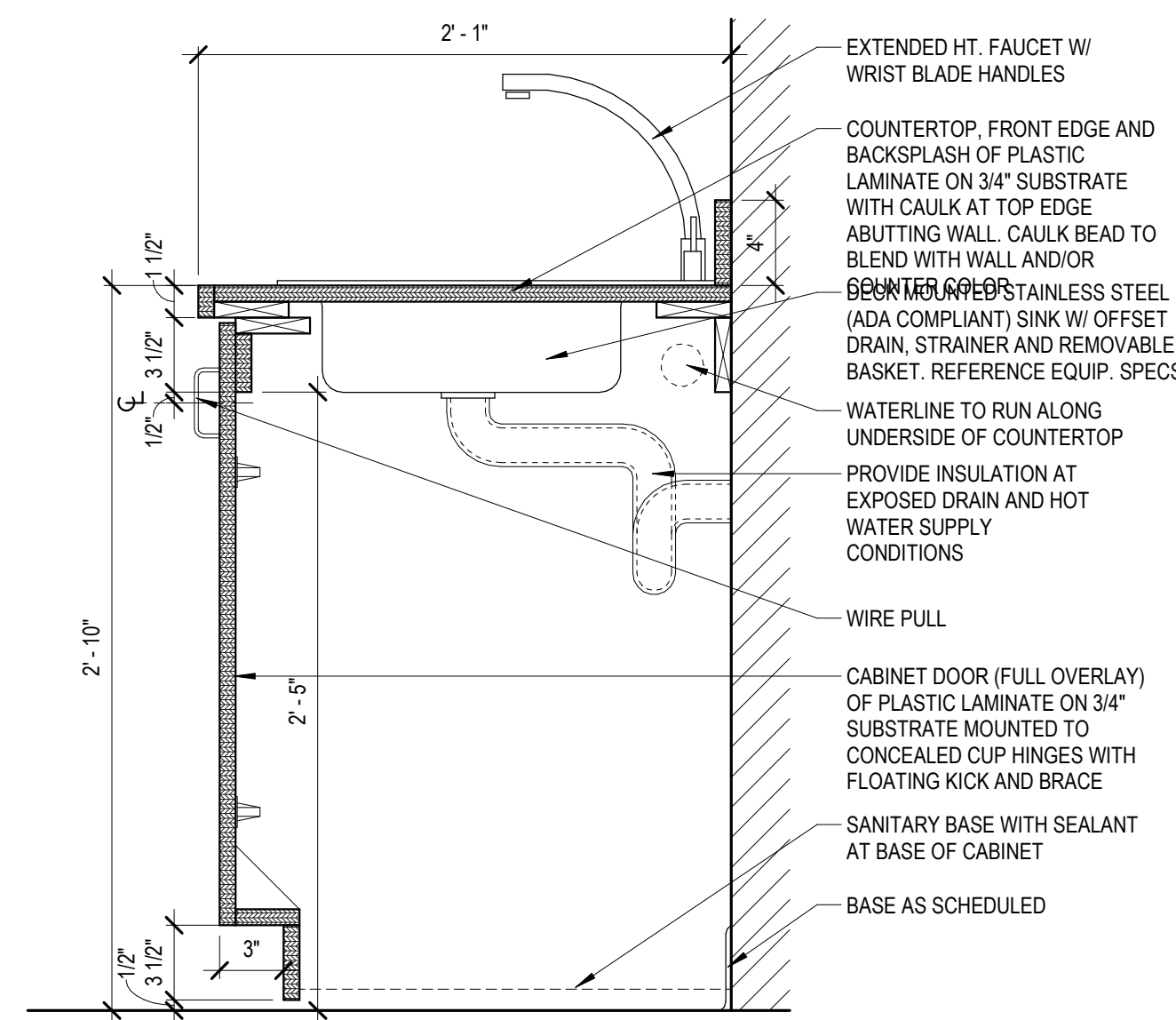

C1 MILLWORK DETAIL
SCALE: 1 1/2" = 1'-0"

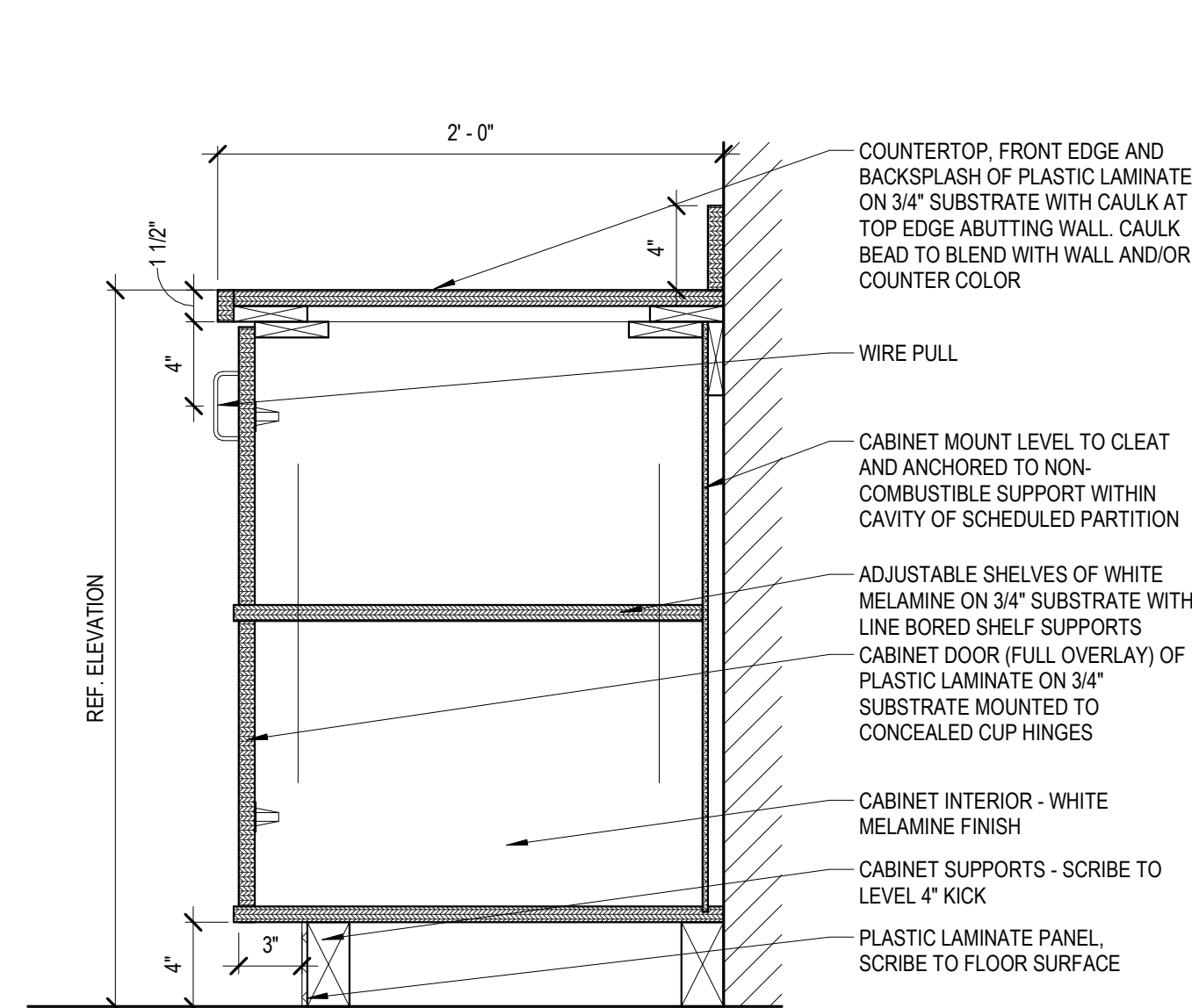

C2 MILLWORK DETAIL
SCALE: 1 1/2" = 1'-0"

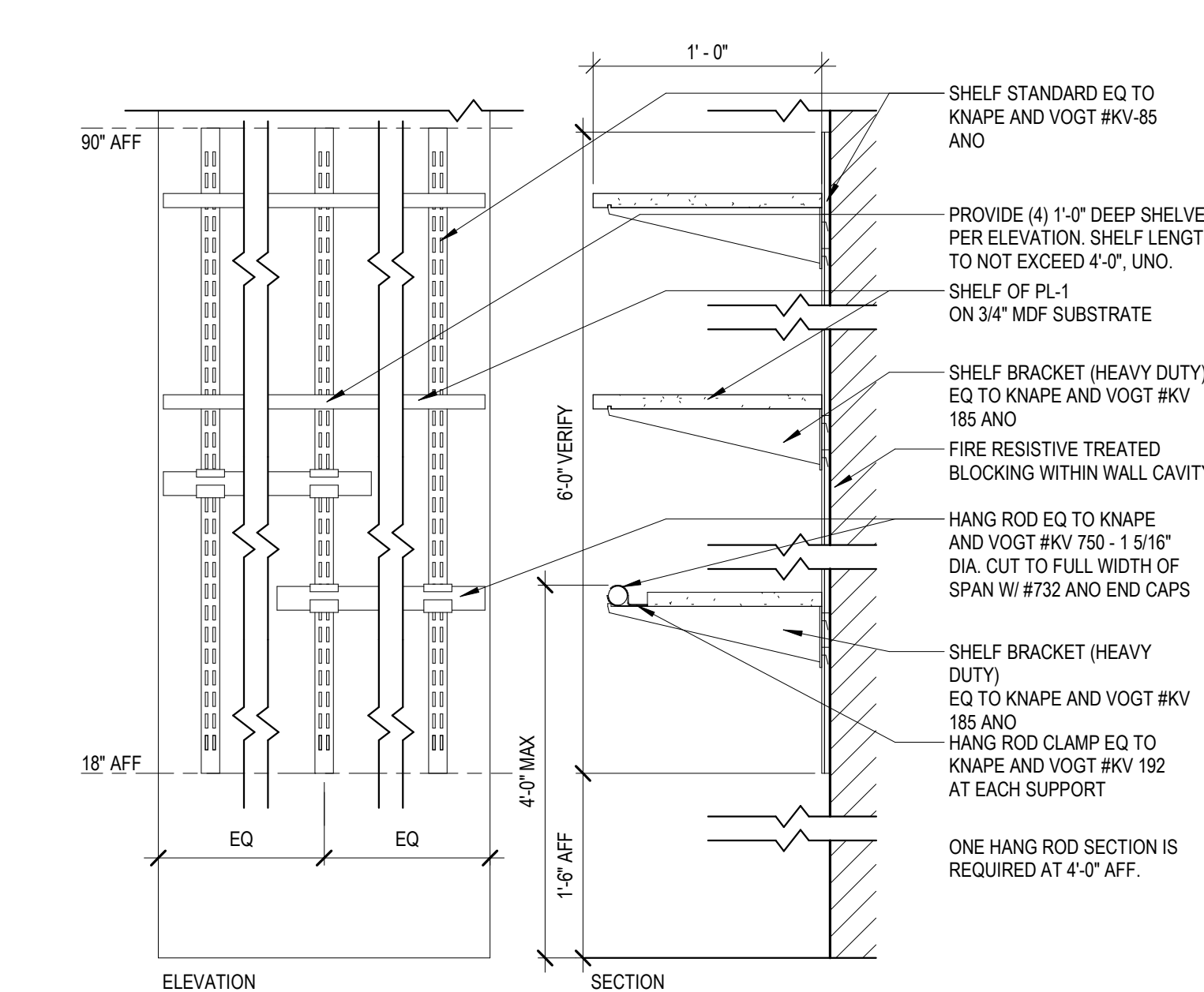

C3 DETAIL @ ROD AND SHELF
SCALE: 1 1/2" = 1'-0"

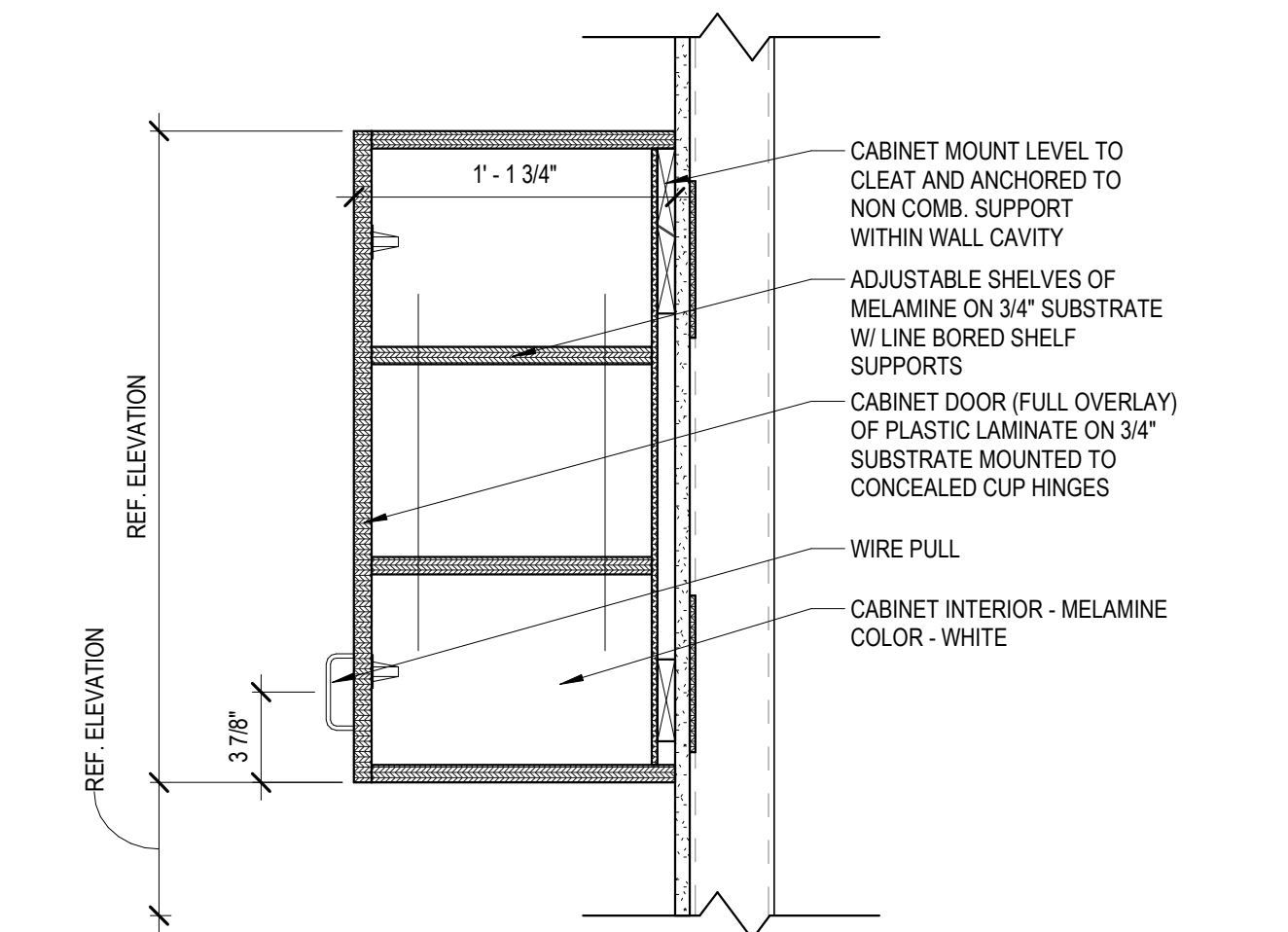

B1 MILLWORK DETAIL
SCALE: 1 1/2" = 1'-0"

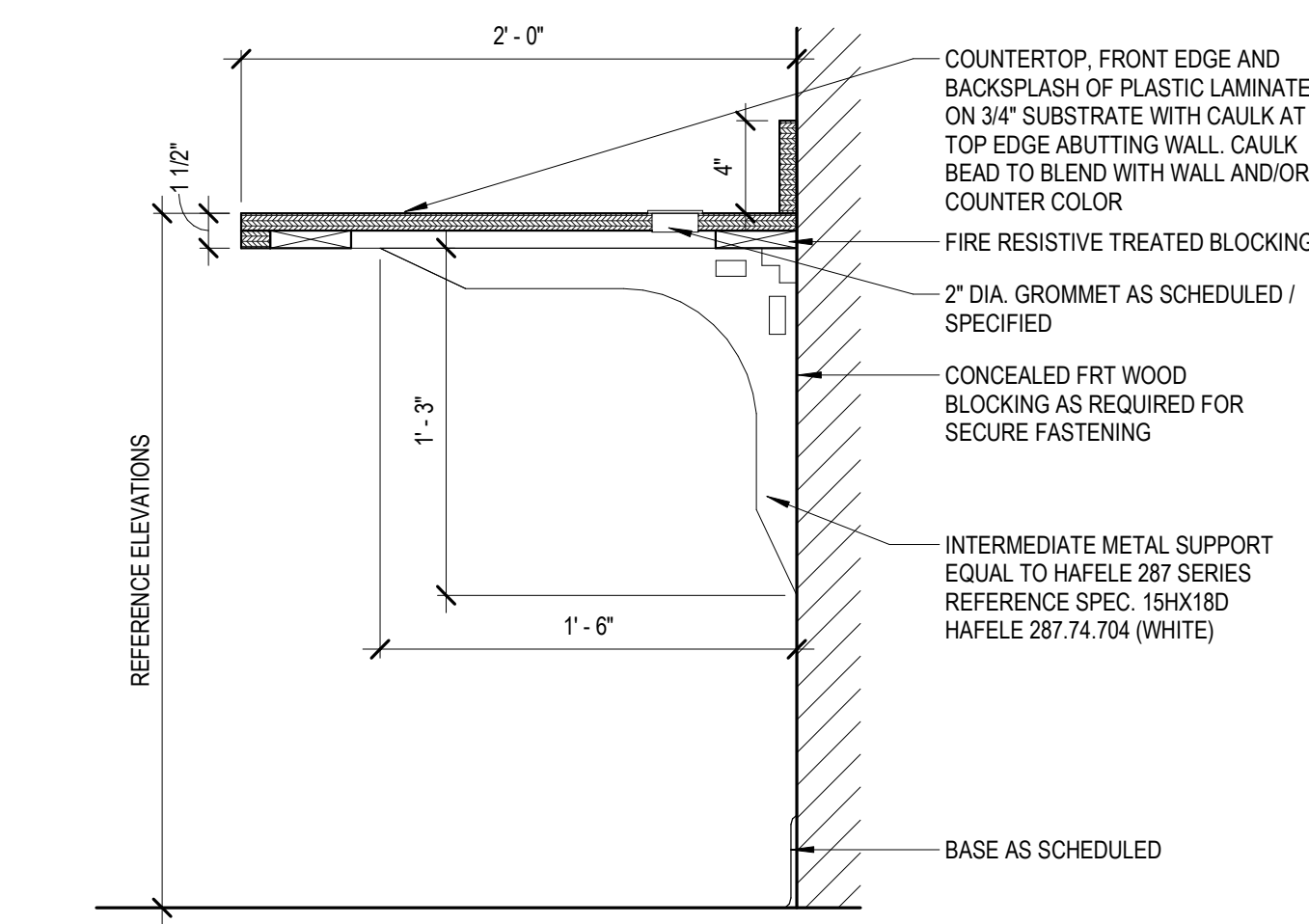

B2 MILLWORK DETAIL
SCALE: 1 1/2" = 1'-0"

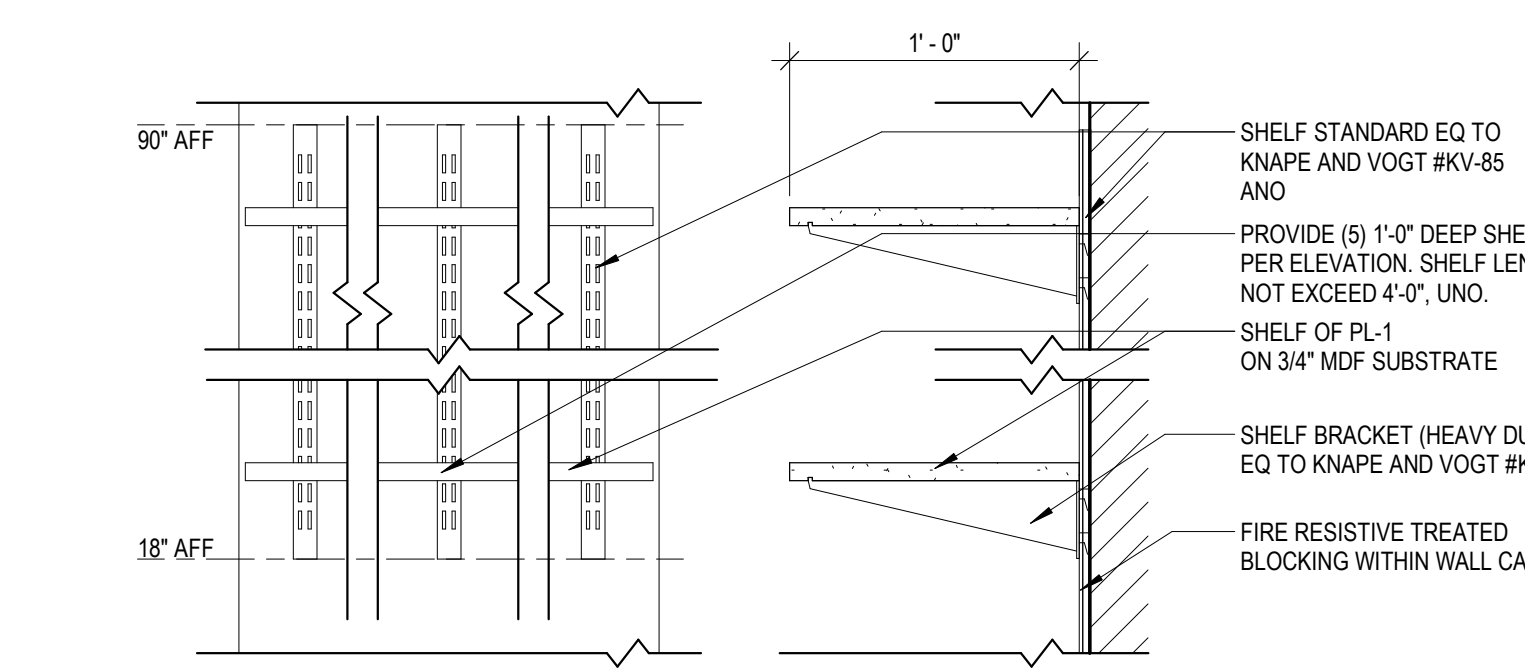

C4 DETAIL @ ADJUSTABLE SHELVES
SCALE: 1 1/2" = 1'-0"

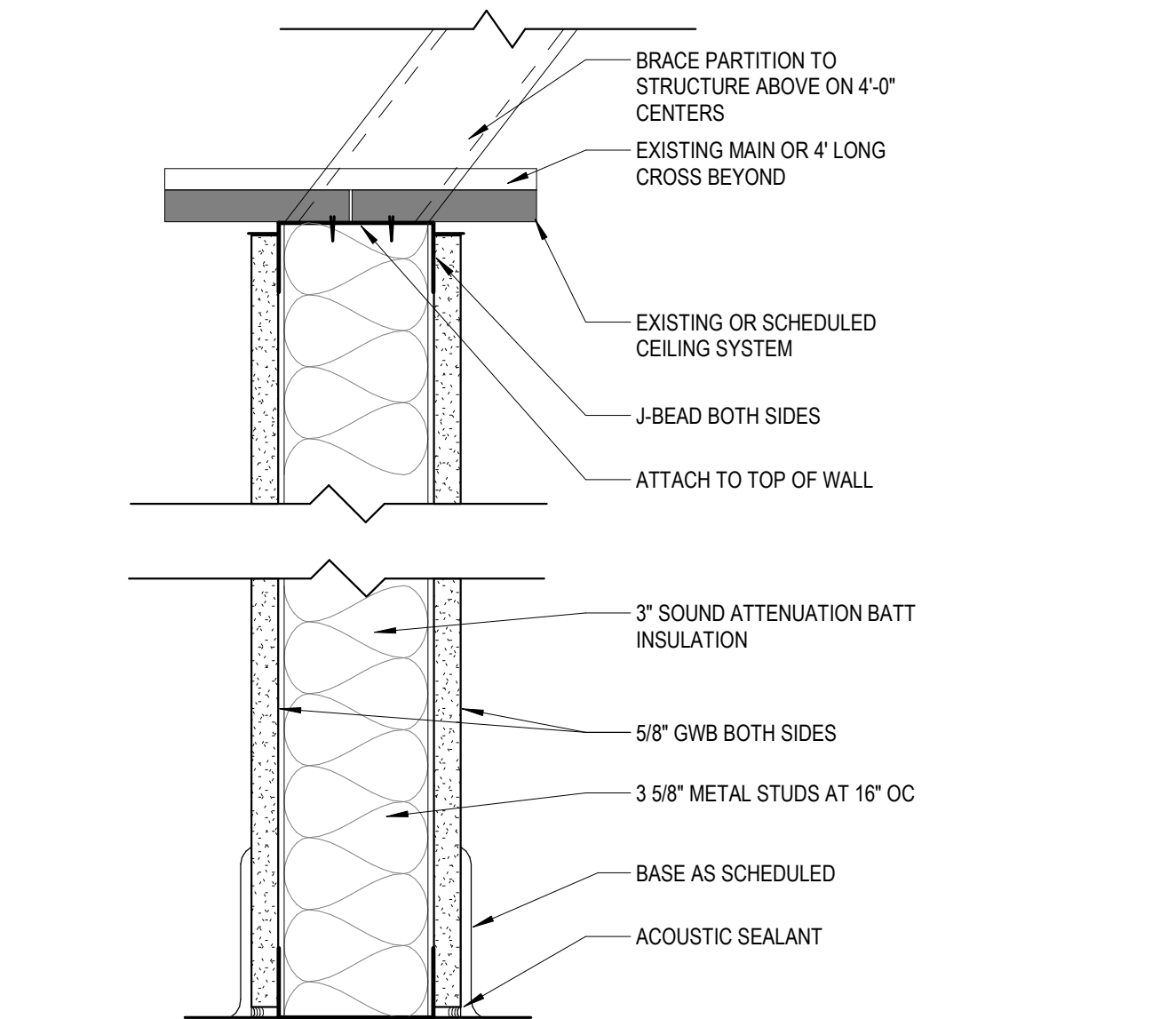

A1 TYPE 1 - TO CLG. (3 5/8")
SCALE: 3" = 1'-0"

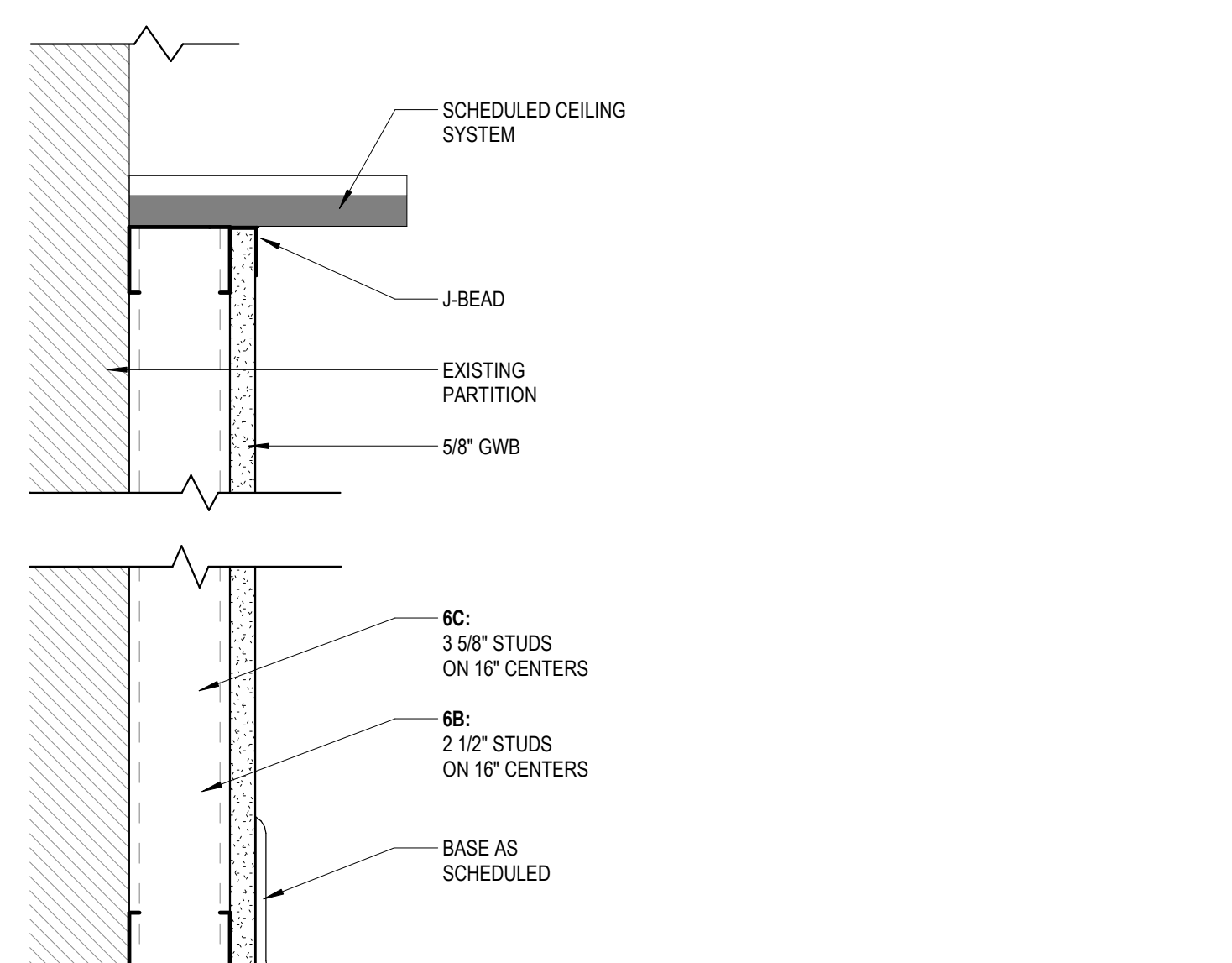

A2 TYPE 6 - FURRING TO CLG.
SCALE: 3" = 1'-0"

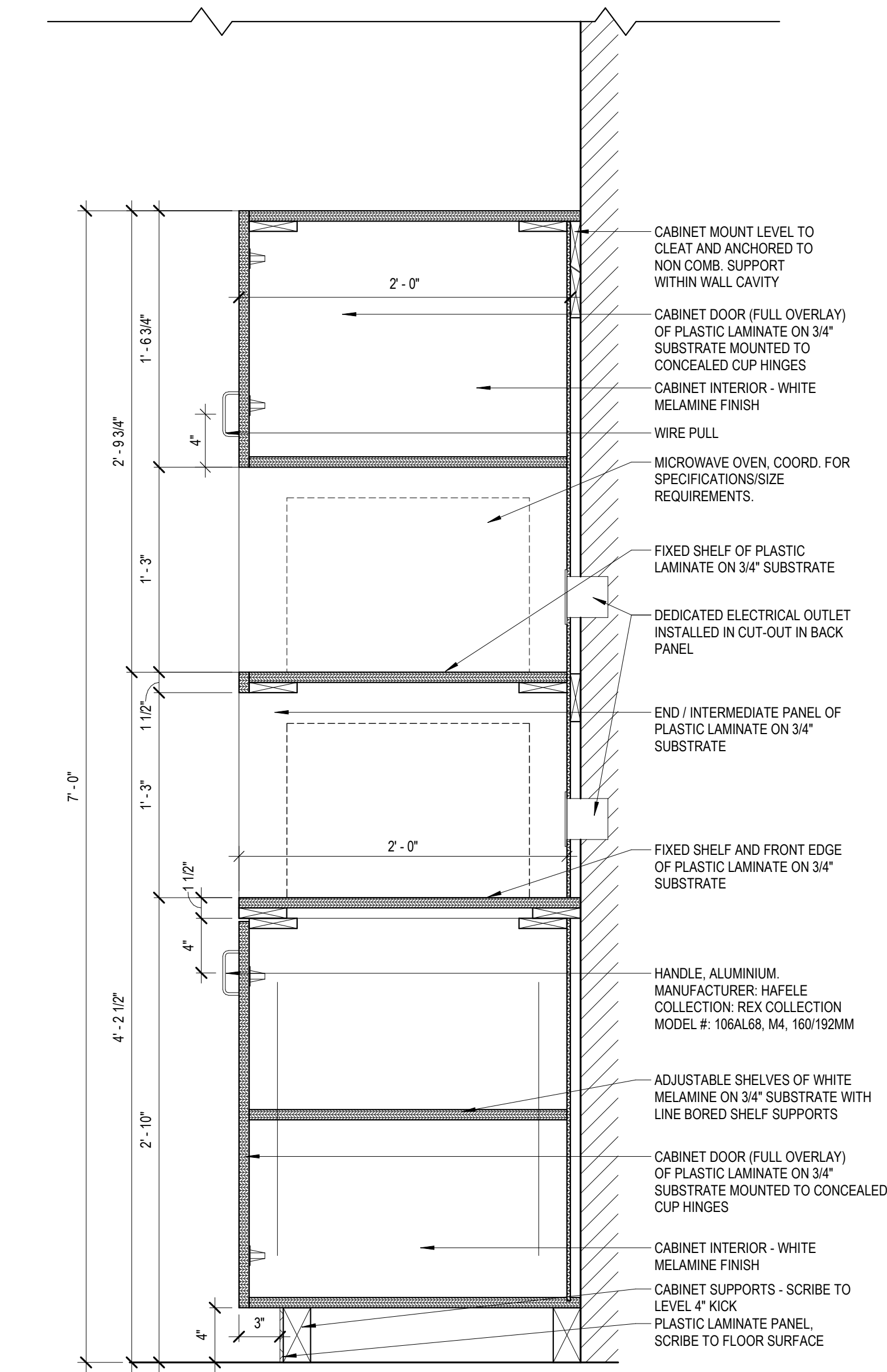

B4 MILLWORK DETAIL
SCALE: 1 1/2" = 1'-0"