

12 Head detail - interior sliding door  
3"=1'-0"

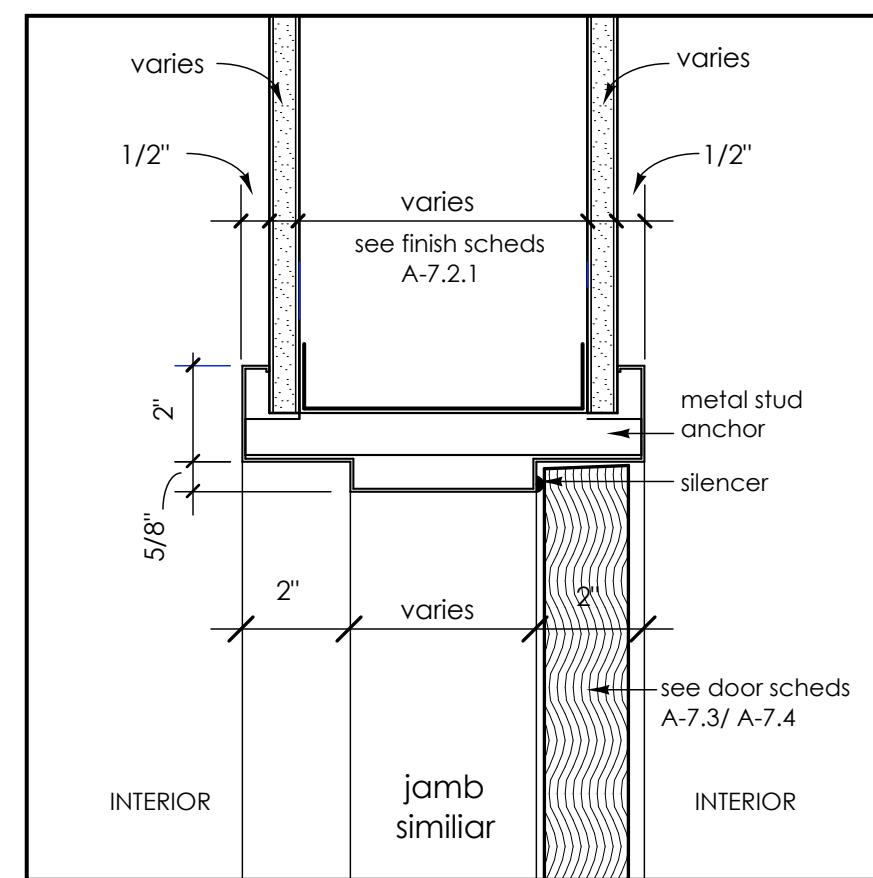

9 Typ. head detail - interior metal stud wall  
See A7.1 and A7.2 for wall types 3"=1'-0"

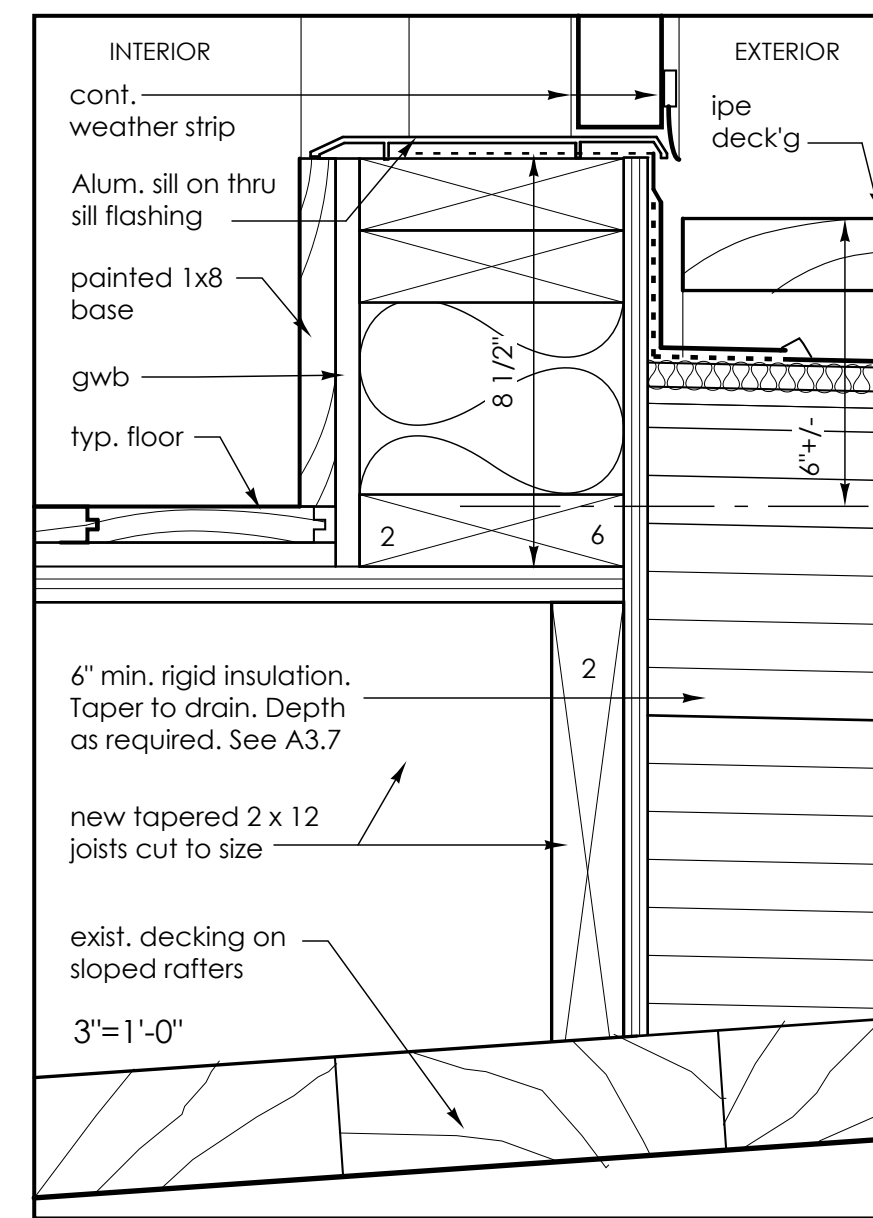

6 Sill detail - Free Street Mezzanine Roof Deck  
See 3/A3.7 adjacent window sill similar - see plan 3"=1'-0"

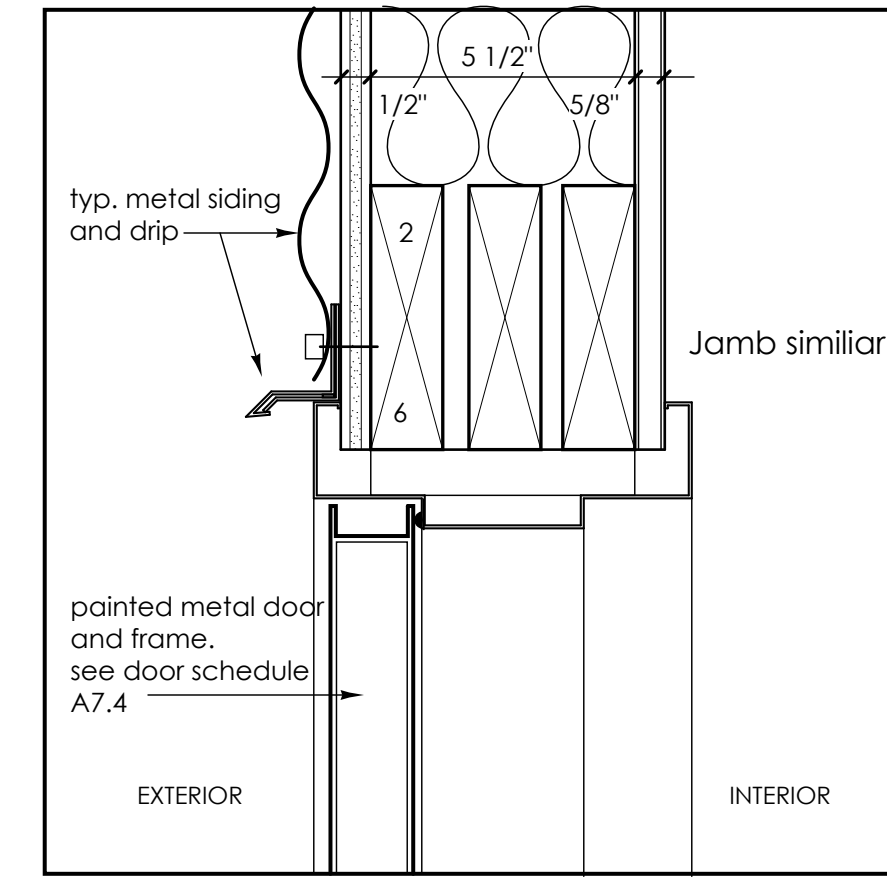

4 Head detail - roof egress stair at Courtyard  
Typ. Metal Frame @ Exterior 2x6 wall. 3"=1'-0"

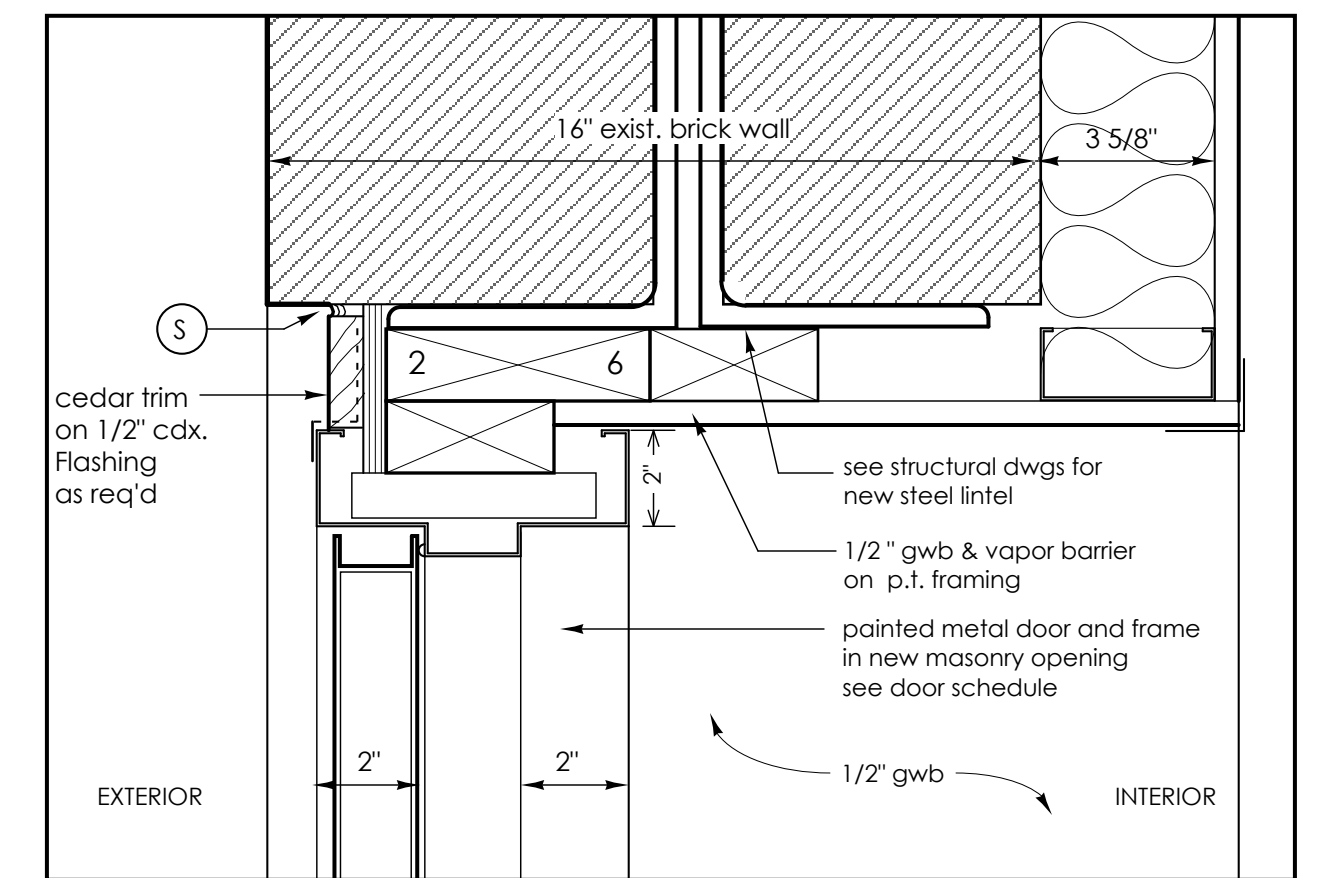

1 Head detail - free street exterior egress door 109B (jamb similar)  
3"=1'-0"

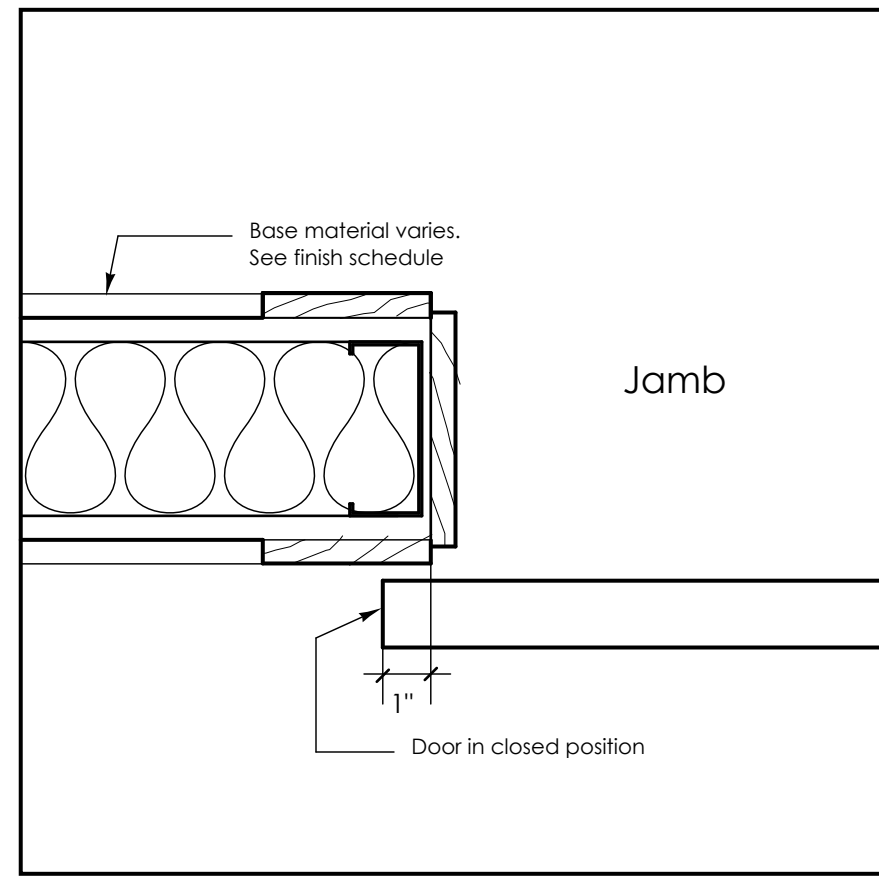

13 Jamb detail - interior sliding door  
3"=1'-0"

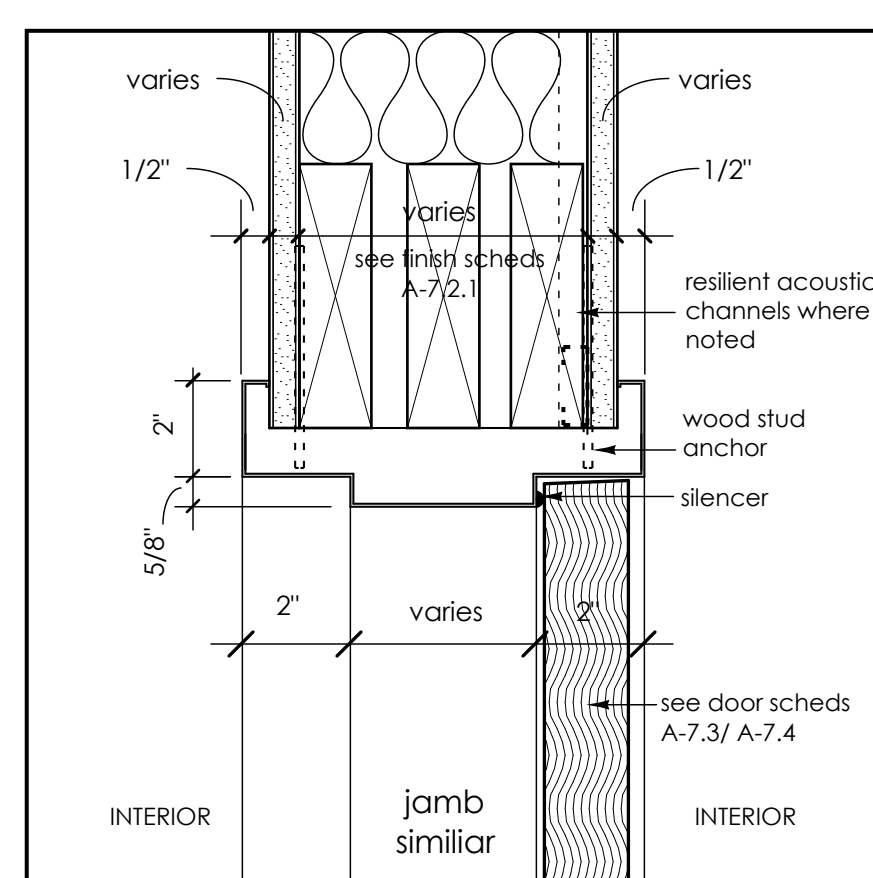

10 Typ. head detail - interior wood stud wall  
See A7.1 and A7.2 for wall types 3"=1'-0"

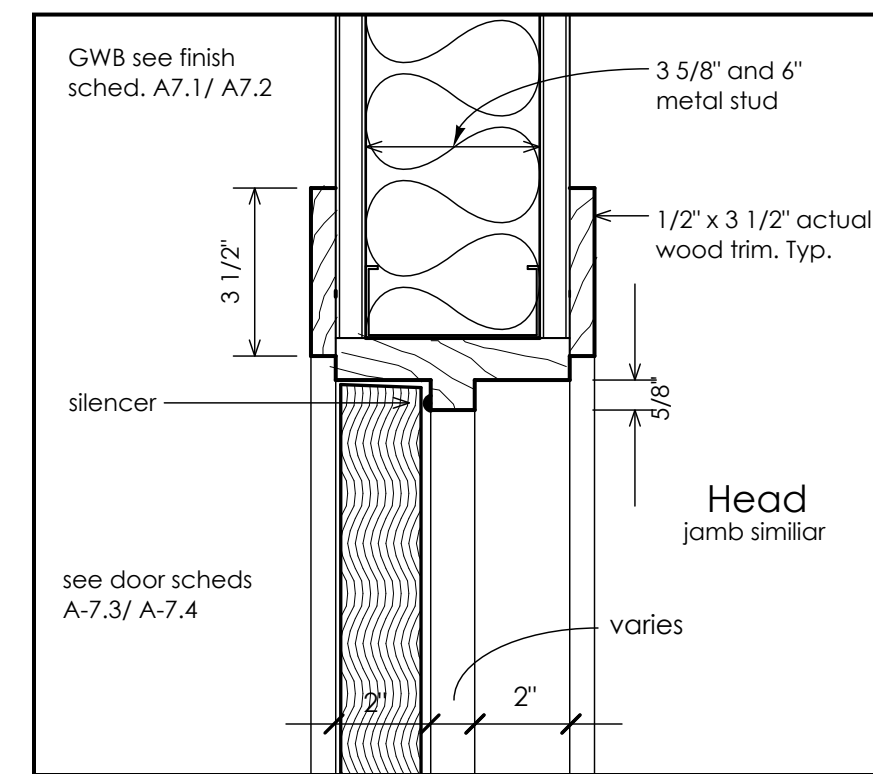

7 Head detail - typ. interior trim  
3"=1'-0"

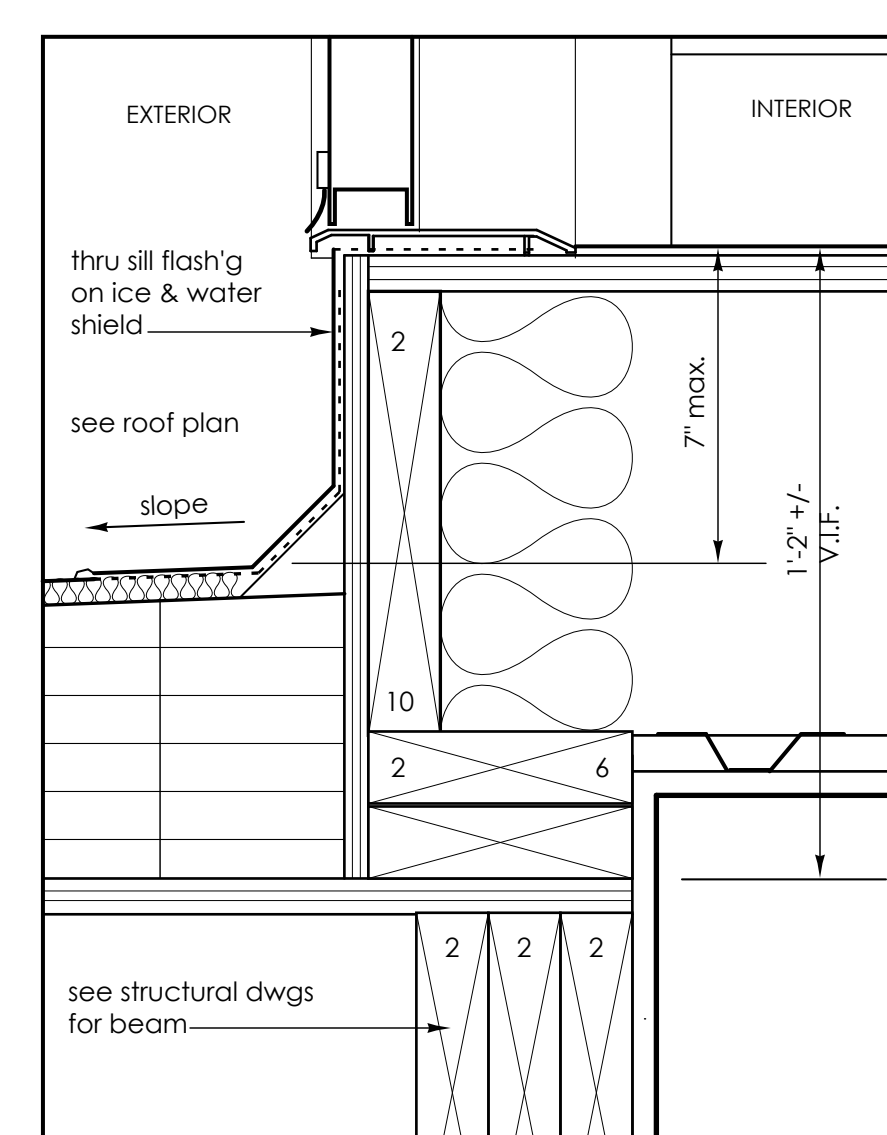

5 Sill detail - roof egress stair door 407A @ Courtyd  
3"=1'-0" see A3.5 and A3.9

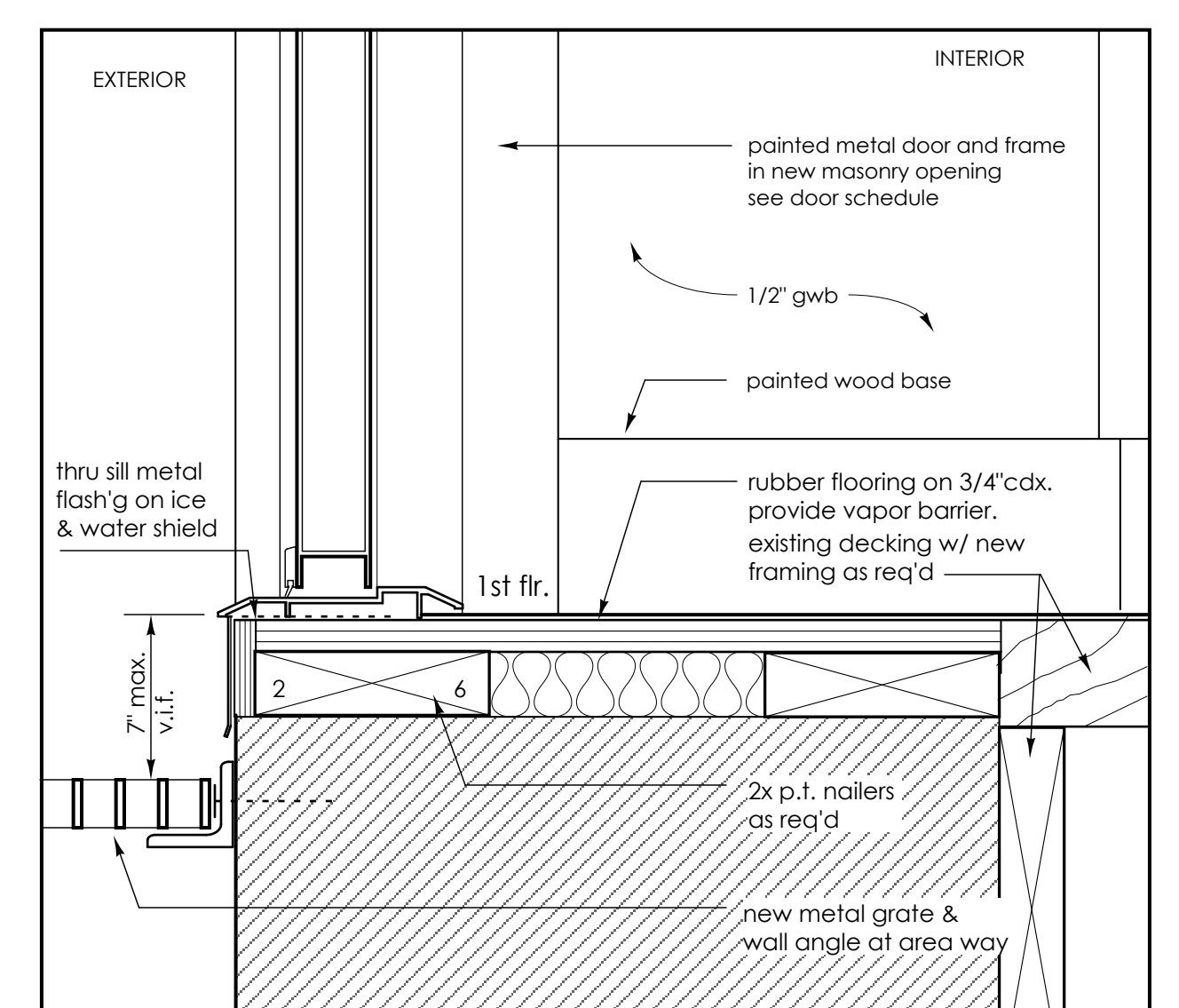

2 Sill detail - free street side exterior egress stair door 109B  
3"=1'-0"

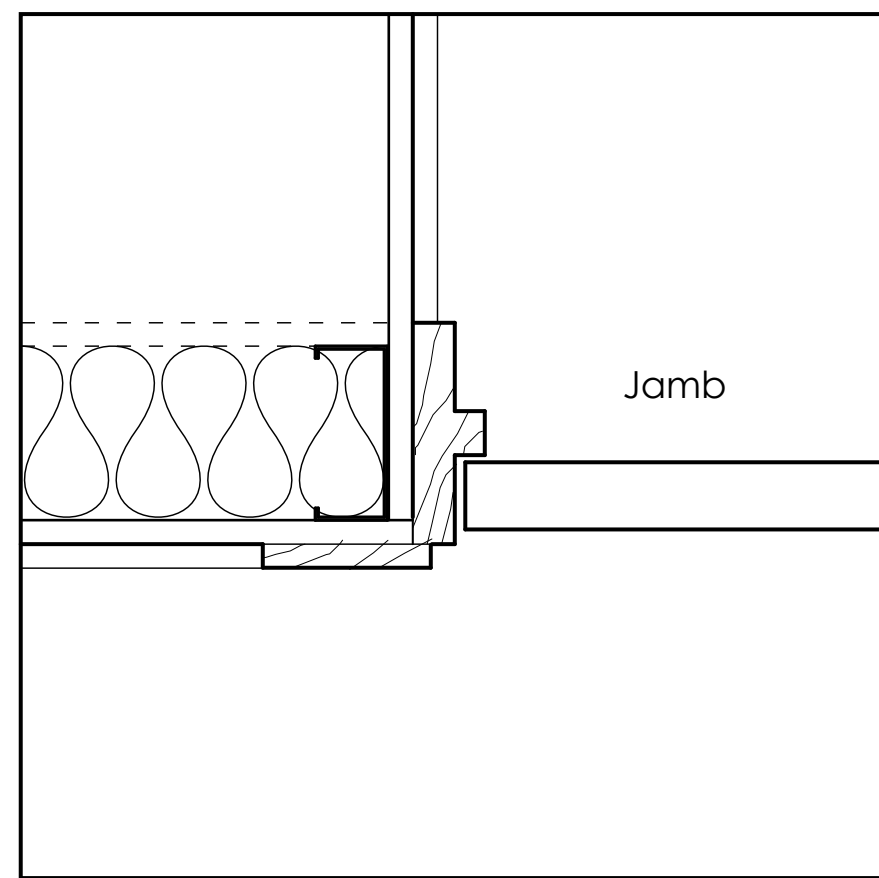

14 Jamb detail - interior sliding door  
3"=1'-0"

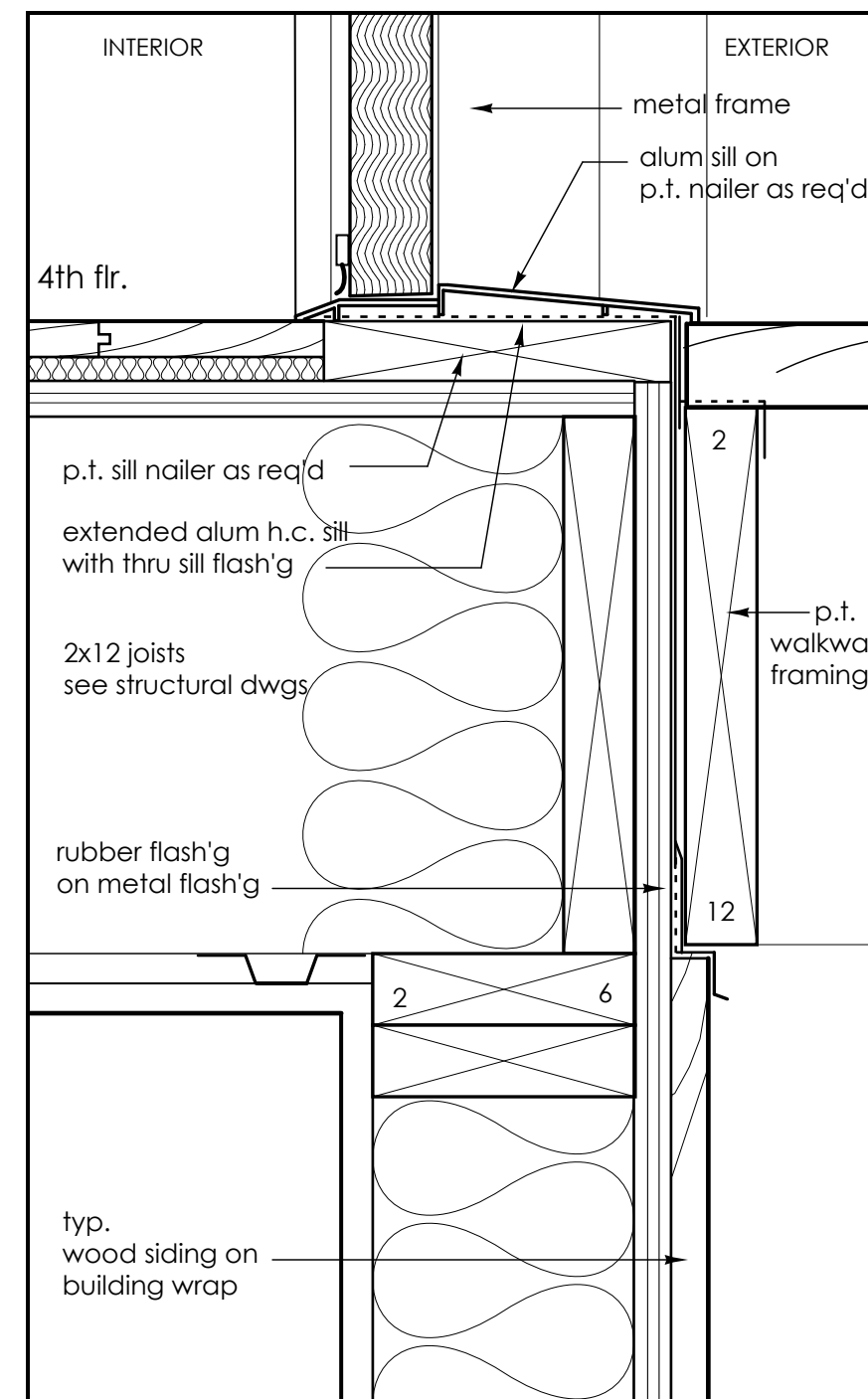

11 Sill detail - Congress St. bldg @ courtyard walkway  
See A3.8 3"=1'-0"

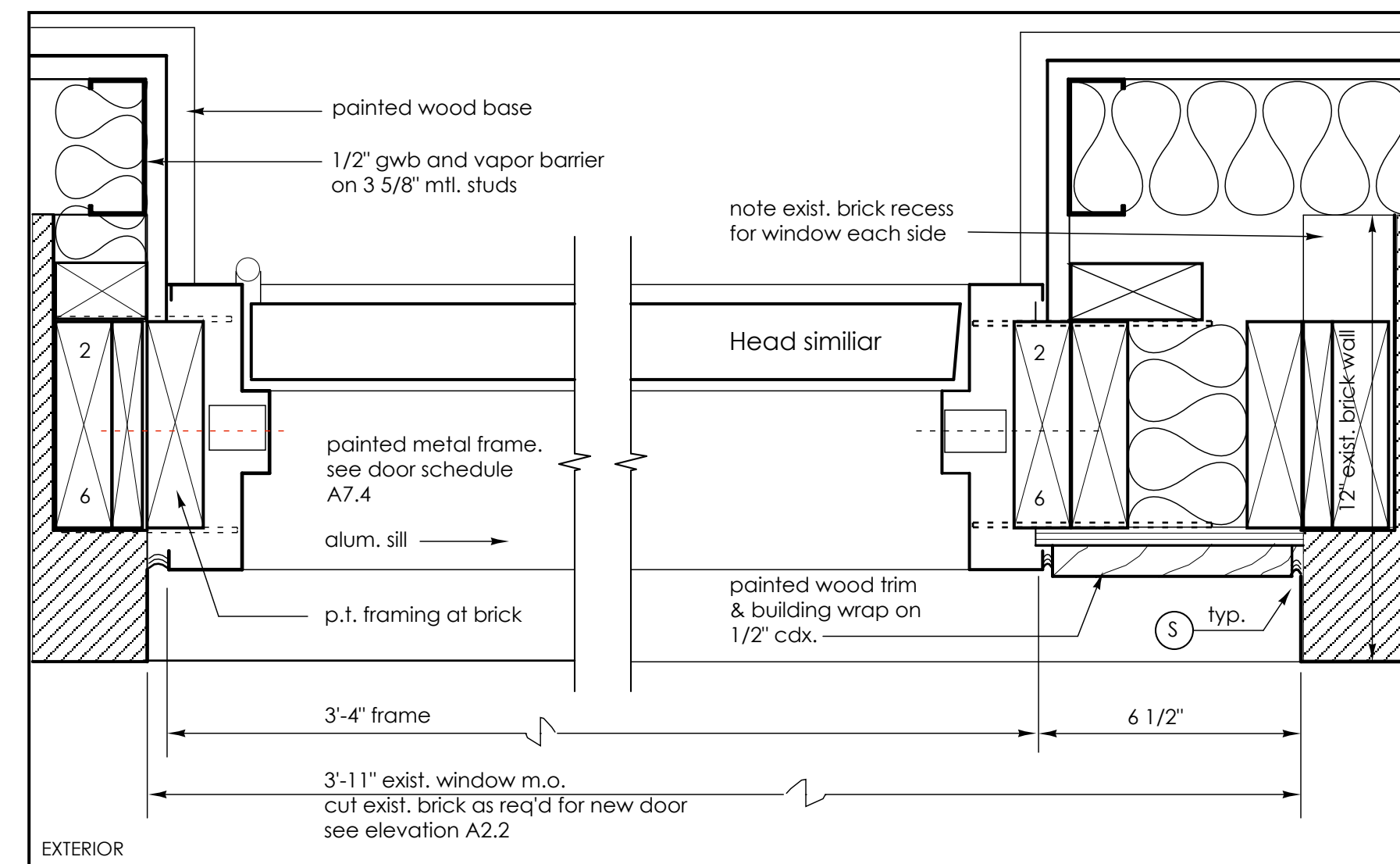

8 Jamb detail - free street courtyard @ new 3rd (305a) and 4th floor (405a) masonry opening.  
See 3 / A5.1 for sill 3"=1'-0"

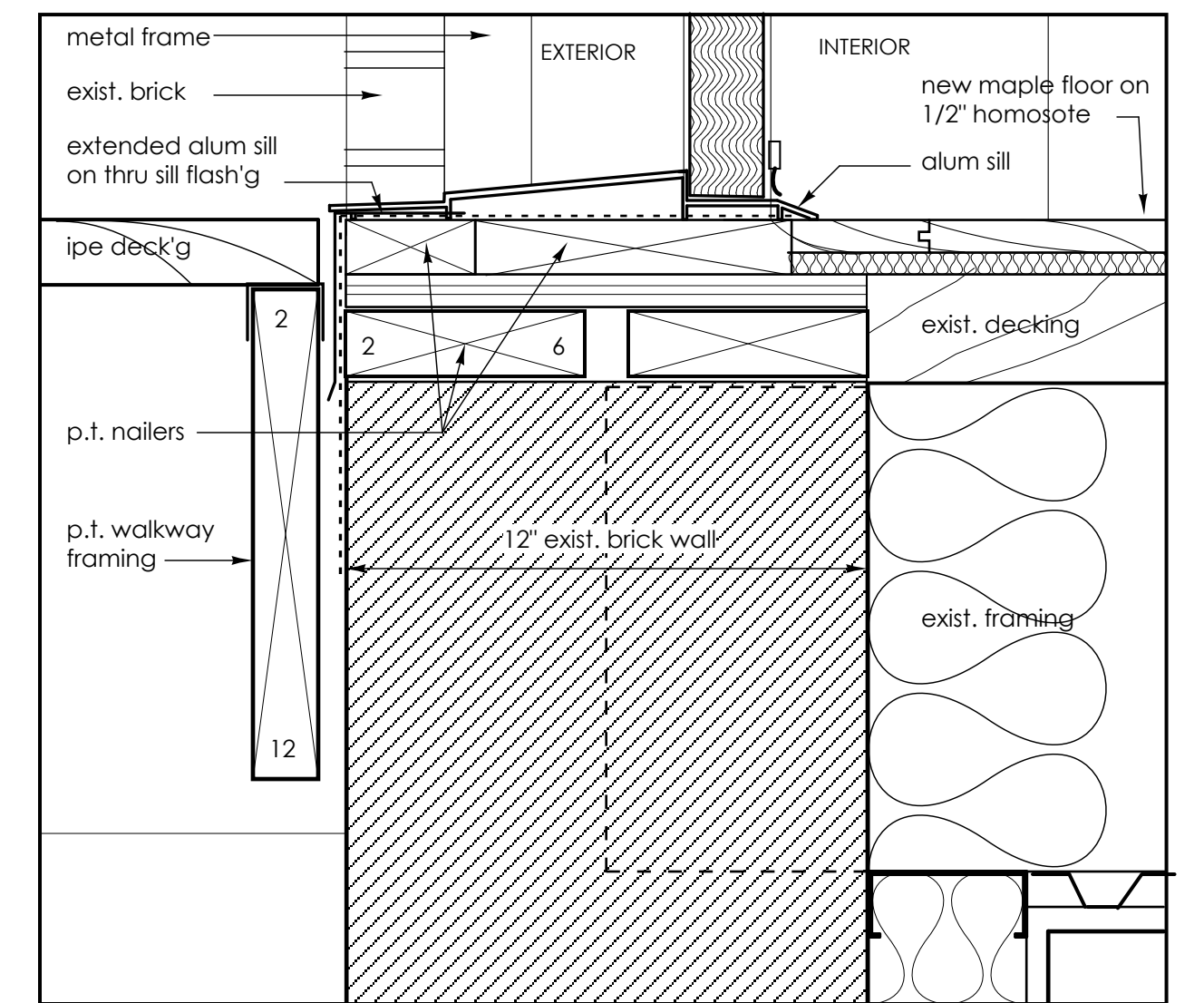

3 Sill detail - free street courtyard @ new 3rd (305a) and 4th floor (405a) masonry opening.  
3"=1'-0"