

**TYPICAL WIRING OF A M500R RELAY CONTROL MODULE**

CONTACT RATINGS  
3 AMPS @ 30VDC  
OR .3 AMPS @ 125VAC

A 4" SQUARE OR A 2 GANG BOX  
3 1/2" DEEP IS REQUIRED FOR MOUNTING

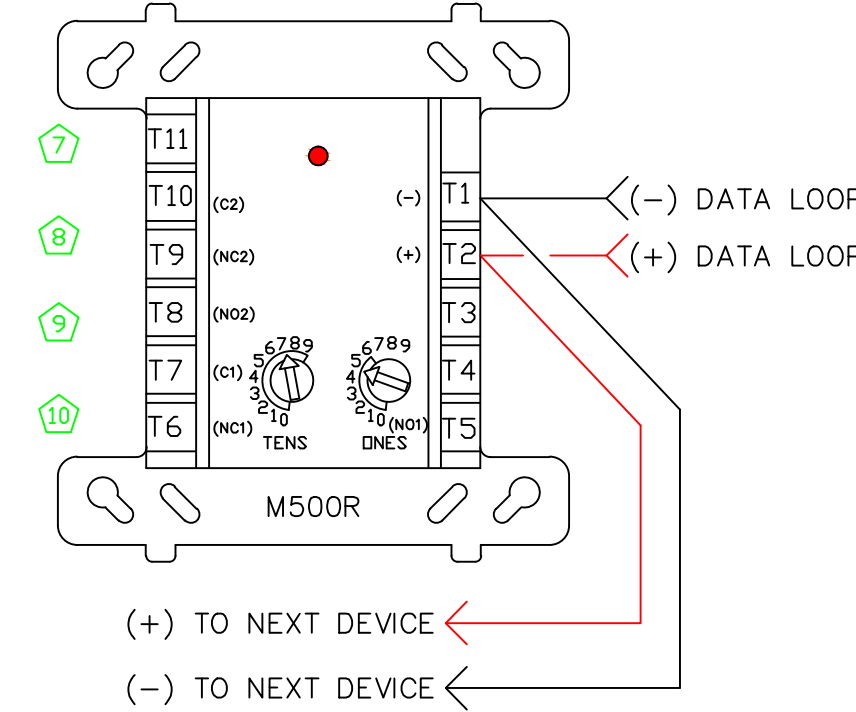

**TYPICAL WIRING OF AN M500M FOR SHUNT TRIP POWER MONITORING**

A 4" SQUARE OR A 2 GANG BOX  
3 1/2" DEEP IS REQUIRED FOR MOUNTING

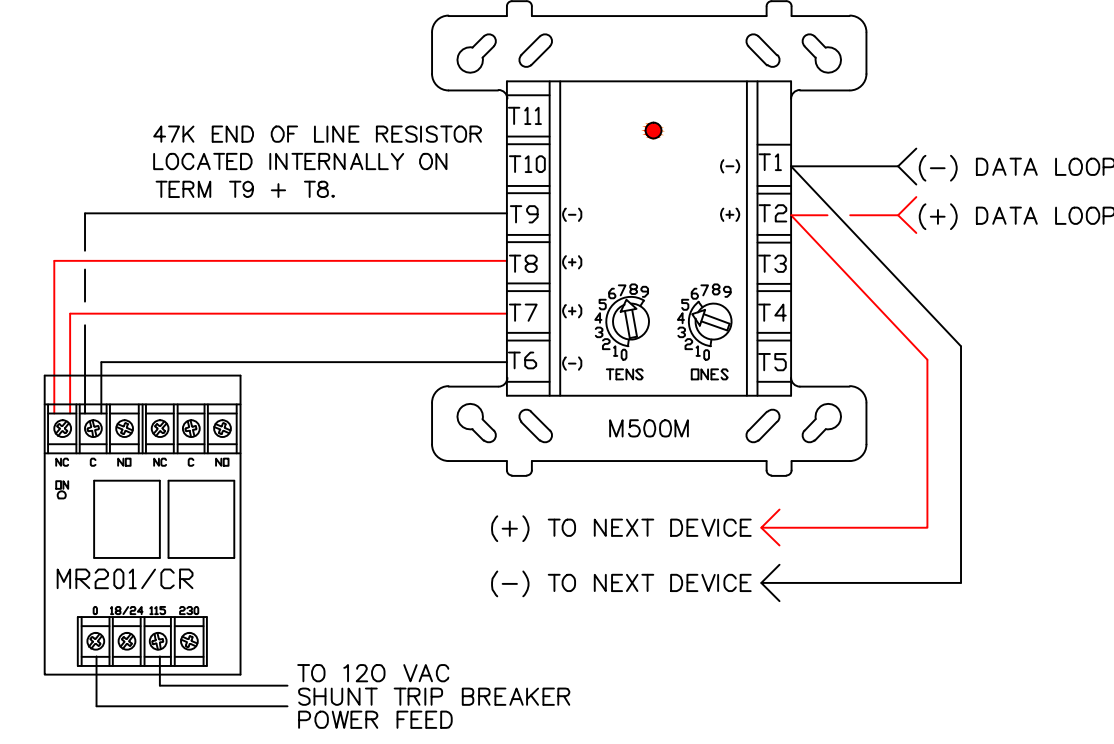

**NOTICE**

Ground terminal must be connected to Earth Ground per Article 760 of the National Electric Code. Failure to make a proper Earth Ground connection to a metal cold water pipe or a driven Ground Rod to this terminal will result in loss of Lightning protection, reduce the tolerance of the system to transients and will adversely affect its operation. Panel Neutral or Conduit Ground is not acceptable. Minimum Wire Size: 12 AWG

Signal Circuit Power Boosters are supplied for additional NAC power as well as to allow the installer to use smaller gauge wire over shorter signal runs. The Signal Circuit Power Booster should be installed in the field in close proximity to the Notification Appliances they are powering.

**WARNING**

THE INSTALLING CONTRACTOR IS RESPONSIBLE FOR THE WIRING OF ALL DEVICES. THE WIRE TYPE AND THAT ALL WIRE SIZES MEET STATE AND LOCAL CODE REQUIREMENTS. THE INSTALLING CONTRACTOR IS ALSO RESPONSIBLE THAT THE INSTALLATION IS FREE OF ALL DEFECTS.

**NOTES**

- Must be grounded to a driven ground rod or the cold water pipe on the street side of the main shut off valve.
- No AC voltage on any terminal other than those specified.
- Maximum line resistance is 40 Ohms, maximum line capacitance is 0.5 micro-farad per loop.
- Existing Notification Devices. Device type & Quantity Unknown.
- Existing Initiating Devices. Device type & Quantity Unknown.
- Existing Voice Devices. Device type & Quantity Unknown.
- To Elevator Controller, Recall Elevator To Primary Floor. Component must be installed within 3' of the controlled device.
- To Elevator Controller, Recall Elevator To Alternate Floor. Component must be installed within 3' of the controlled device.
- To Elevator Controller, Firemans Hat Warning Light. Component must be installed within 3' of the controlled device.
- To Elevator Shunt Trip Breaker. Component must be installed within 3' of the controlled device.

**GENERAL NOTES**

- ALL Fire Alarm System wiring shall comply with the National Electrical Code, Applicable State and Local Fire and Safety Codes, as well as being coordinated with the Local Authority Having Jurisdiction.
- CAUTION DO NOT connect any power to control panel (batteries or 120 vac) until all other field wiring is tested and connected.
- DO NOT install FACP or smoke detectors in any unheated area.
- DO NOT install any AC current carrying conductors close to or in the same raceway with Fire alarm system conductors.
- Dotted lines indicate factory wiring. Solid lines indicate connections to be made by the installer.
- See Installation Manual for additional wiring instructions.
- All relays are shown in normal supervisory condition. All relay dry contacts 28 VDC @ 1A DONLY.
- FACP Indicating circuit outputs are 17 amps at 24 VDC per circuit. INX/10A circuit outputs are 2.5 amps, each. Not to exceed 10 amps total.
- Cabinet Dimensions:  
NDE1 (BBK-FXMS) - L 61.5000" W 20.0000" D 9.0000"  
INX-10A - L 20.0000" W 14.5000" D 4.5000"  
FX-LDR - L 25.0000" W 15.0000" D 5.5000"

**SPECIAL FUNCTIONS**

All Wiring To Be Class A.  
Existing Strobes Are Not Synchronized & Will Not Be Synchronized With New Devices.

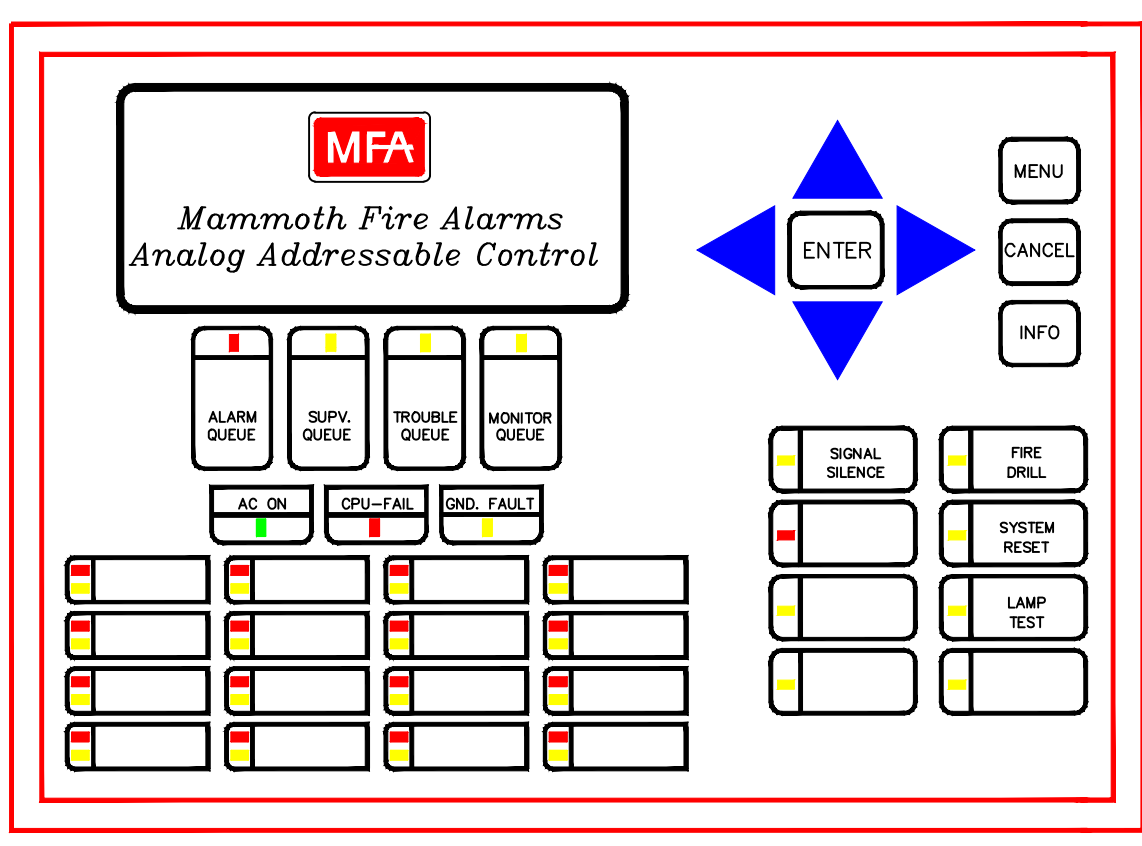
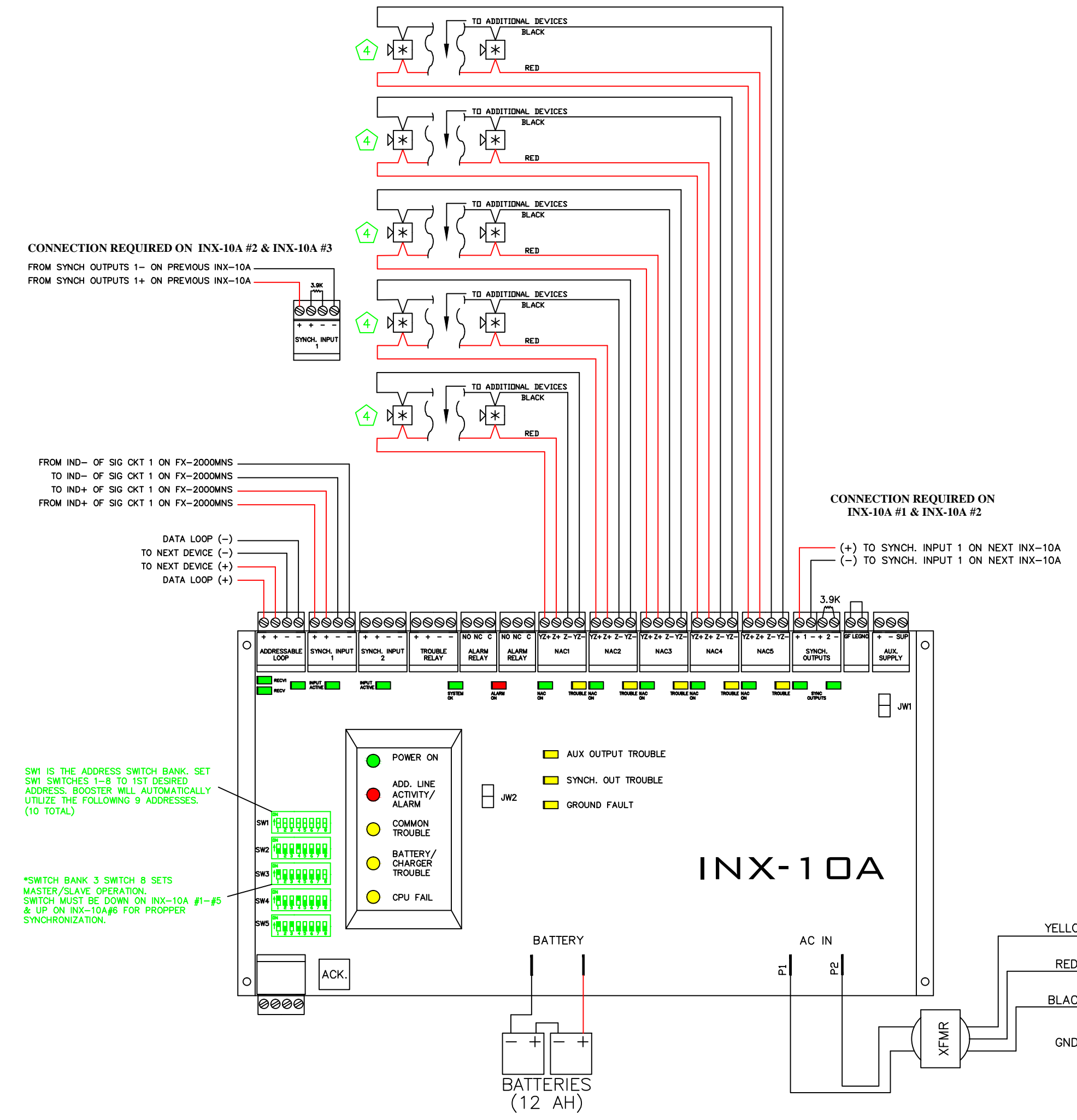
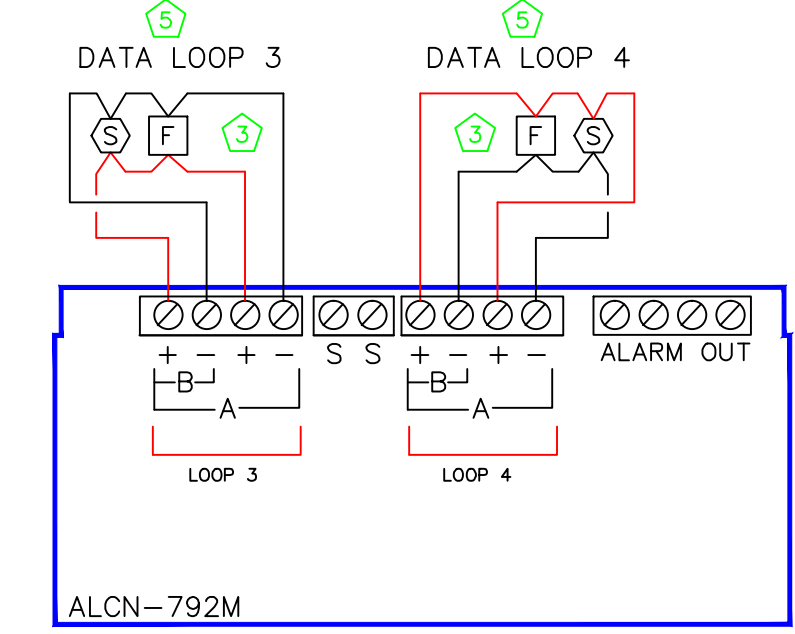
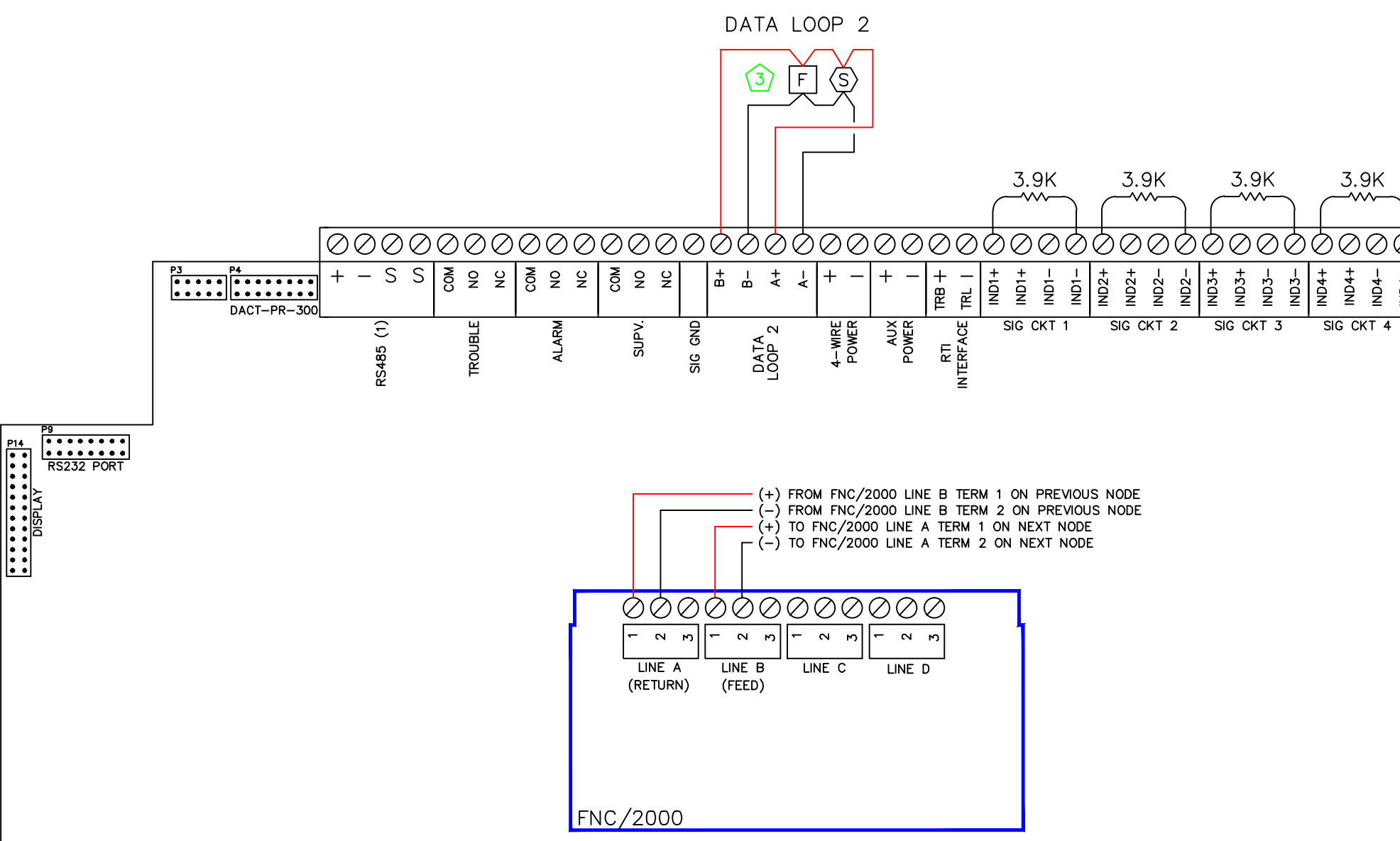

**FX2000ND (NODE 2)**

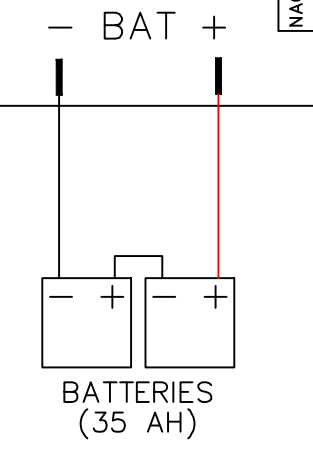

**Audio Note:**  
Existing System is 70 VAC.  
New Speaker devices are 25 VAC.  
As a rule of thumb, speaker taps should be set according to strobe candle ratings.  
15cd = 1/4 watt, 30cd = 1/2 watt, 75cd = 1 watt, & 110cd = 2 watts.  
Individual speakers that do not have a strobe are generally set to 1/4 watt.  
Ambient conditions in building may require further adjustments to meet the required decibel level.

Prepared By:  
**MFA Mammoth Fire Alarms Incorporated**  
1-800-995-9808  
Lowell, MA 01854-3126

Property Protection Monitoring  
1-877-794-1144  
Lowell, MA 01854-3126

Mammoth Fire Protection Systems  
1-877-437-3569  
Lowell, MA 01854-3126

Scale: None Approved By: Drawn By: MAD  
Date: 3/20/15 Mike K 3/20/15 Revised:

Project Info:  
Maine College of Art (Basement Renovation)  
522 Congress Street Portland, Me.  
Prepared For:  
Mancini Electric  
179 Sheridan Street Portland, Me. 04101

FA-104