

PARTITION TYPE MARK	FRAMING			DETAILS		ATTN	FIRE RTG	TESTED ASSEMBLY	STC RTG
	THK (IN)	DEPT H	SPACIN G	TOP	BOT				
Q				Q-T01	Q-B01				

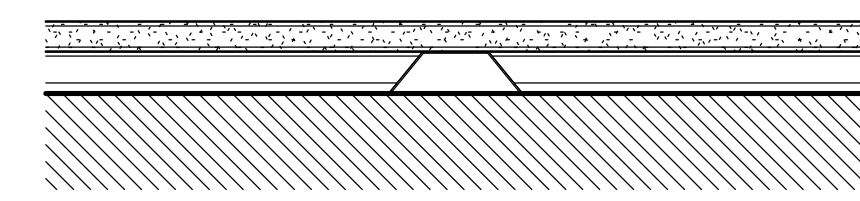

PARTITION TYPE MARK	FRAMING			DETAILS		ATTN	FIRE RTG	TESTED ASSEMBLY	STC RTG
	THK (IN)	DEPT H	SPACIN G	TOP	BOT				
F3		3/4"		F-T04	F-B01				

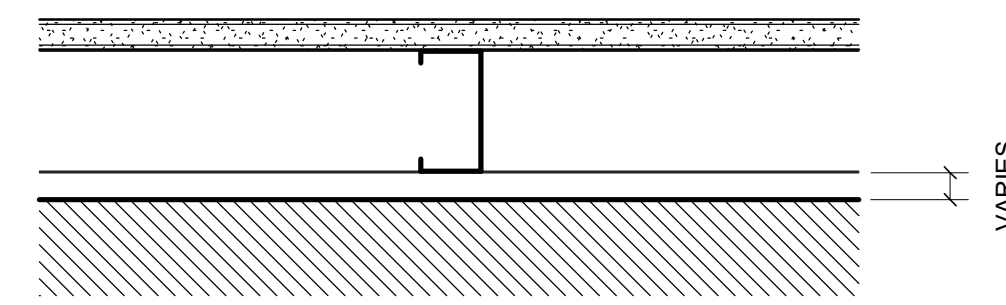

PARTITION TYPE MARK	FRAMING			DETAILS		ATTN THK	FIRE RTG	TESTED ASSEMBLY	STC RTG
	THK (MILS)	DEPT H	SPACIN G	TOP	BOT				
D2A	27	2 1/2"	16" O.C.	D-T04	D-B01				
D2B	27	2 1/2"	16" O.C.	D-T01	D-B01				
D3A	30	3 5/8"	16" O.C.	D-T04	D-B01				
D3B	30	3 5/8"	16" O.C.	D-T01	D-B01				
D3C	30	3 5/8"	16" O.C.	D-T01	D-B01				

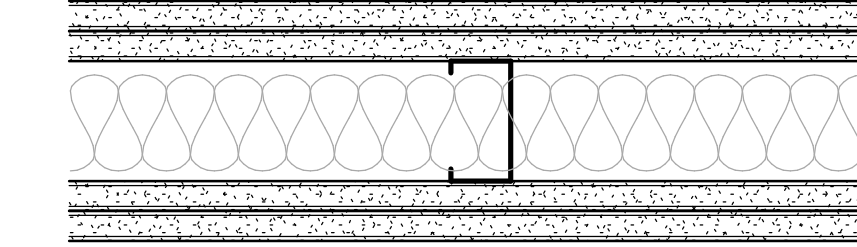

PARTITION TYPE MARK	FRAMING			DETAILS		ATTN THK	FIRE RTG	TESTED ASSEMBLY	STC RTG
	THK (MILS)	DEPTH	SPACING	TOP	BOT				
B3A	30	3 5/8"	16" O.C.	B-T01	B-B01	3 1/2"	2	UL419	

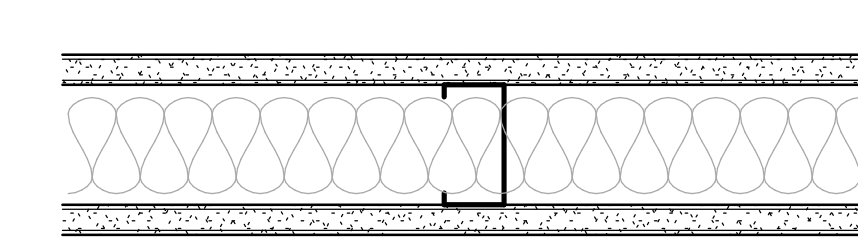

PARTITION TYPE MARK	FRAMING			DETAILS		ATTN THK	FIRE RTG	TESTED ASSEMBLY	STC RTG
	THK (MILS)	DEPTH	SPACING	TOP	BOT				
A2A		2 1/2"		A-T04					
A3A	30	3 5/8"	16" O.C.	A-T04	A-B01	3 1/2"			
A3B	30	3 5/8"	16" O.C.	A-T02	A-B01	3 1/2"			
A6A	27	6"	16" O.C.	A-T04	A-B01	5 1/2"			
A6B	27	6"	16" O.C.	A-T02	A-B01	5 1/2"			
A6C	27	6"	16" O.C.	A-T05	A-B01	5 1/2"			

PARTITION LEGEND

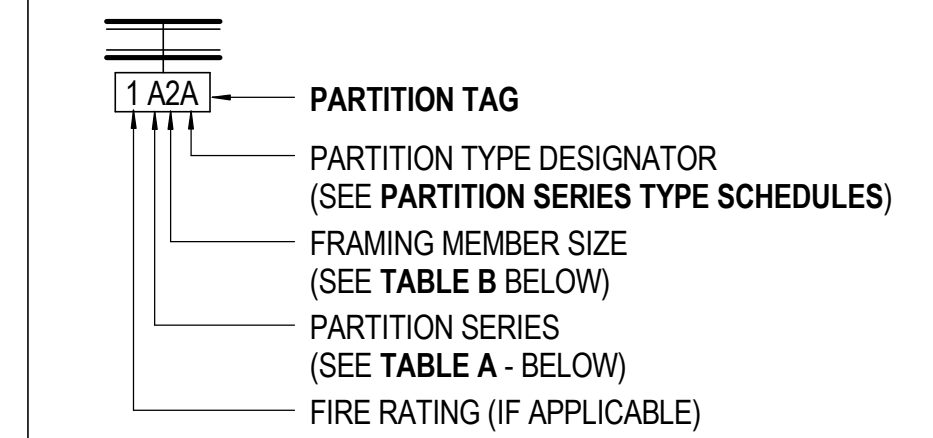

TABLE A - PARTITION SERIES CONSTRUCTION ASSEMBLY

SERIES	SHEATHING	FRAMING MEMBERS	SHEATHING
A	1 - LAYER	METAL C-STUD	1 - LAYER
B	2 - LAYERS	METAL C-STUD	2 - LAYERS
C	1 - LAYER	METAL C-STUD	2 - LAYERS
D	1 - LAYER	METAL C-STUD	NONE
E	2 - LAYERS	METAL C-STUD	NONE
F	1 - LAYER	MTL HAT CHANNEL	NONE
G	1 - LAYER	NONE	NONE
H	1 - LAYER	METAL C-H STUD	NONE
J	2 - LAYERS	METAL C-H STUD	LINER PANEL
K	1 - LAYER	(2) METAL C STUDS	1 - LAYER
L	2 - LAYERS	(2) METAL C STUDS	2 - LAYERS
M	NONE	CMU	NONE

TABLE B - FRAMING DEPTH SCHEDULE

TAG NUMBER	MTL STUD DEPTH	MTL C-H STUD DEPTH	WOOD STUD DEPTH
0	NO FRAMING		
1	7/8" FURRING CHANNEL	N/A	N/A
2	1 5/8"	N/A	N/A
3	2 1/2"	2 1/2"	N/A
4	3 5/8"	N/A	N/A
6	4"	4"	3 1/2"
8	6"	6"	5 1/2"
10	8"	N/A	7 1/4"

GENERAL NOTES

- PARTITION TYPES ARE NOT SEQUENTIAL AND MAY NOT BE USED. REFER TO PLANS FOR PARTITIONS USED IN WORK.
- ALL PARTITION SHEATHING TO BE 5/8" GYPSUM BOARD UNLESS OTHERWISE NOTED.
- ALL PARTITIONS SHALL BE COORDINATED WITH SCHEDULED FINISHES FOR PARTITION LAYOUT AND REQUIRED CLEARANCES.
- PROVIDE BLOCKING IN WALLS FOR ARTWORK HANGING AS INDICATED. COORDINATE WITH ART CONSULTANT FOR INTERIOR ELEVATIONS AND LOCATIONS.
- FOR INTERIOR FRAMING LIMITING HEIGHTS REFER TO ASTM C-754, TABLE(S) 3 AND 4.
- CONTRACTOR TO RE-CONFIRM STUD SIZING AND SUBMIT SELECTION CRITERIA FOR REVIEW INCLUDING DELINEATION OF SLAB TO UNDERSIDE OF SLAB INFORMATION.
- PROVIDE 1/2" CEMENTITIOUS BACKER BOARD IN LIEU OF PARTITION GWB BEHIND TILE LOCATIONS.
- GWB SEAMS SHOULD BE STAGGERED BETWEEN DOUBLE LAYERS OF DRYWALL.
- INSTALL JUNCTION BOXES THAT SERVE OPPOSITE SIDES OF A WALL IN SEPARATE STUD CAVITIES.
- INSTALL INSULATION PAD BEHIND JUNCTION BOXES FOR STC-50 - INSULATION IS TO BE CONTINUOUS AND MIGHT BE COMPRESSED.

Date: 08/18/17 Description: ISSUE FOR PERMIT & CONSTRUCTION

Q SERIES PARTITION TYPES

SCALE: 3" = 1'-0"

F SERIES PARTITION TYPES

SCALE: 3" = 1'-0"

D SERIES PARTITION TYPES

SCALE: 3" = 1'-0"

B SERIES PARTITION TYPES

SCALE: 3" = 1'-0"

A SERIES PARTITION TYPES

SCALE: 3" = 1'-0"

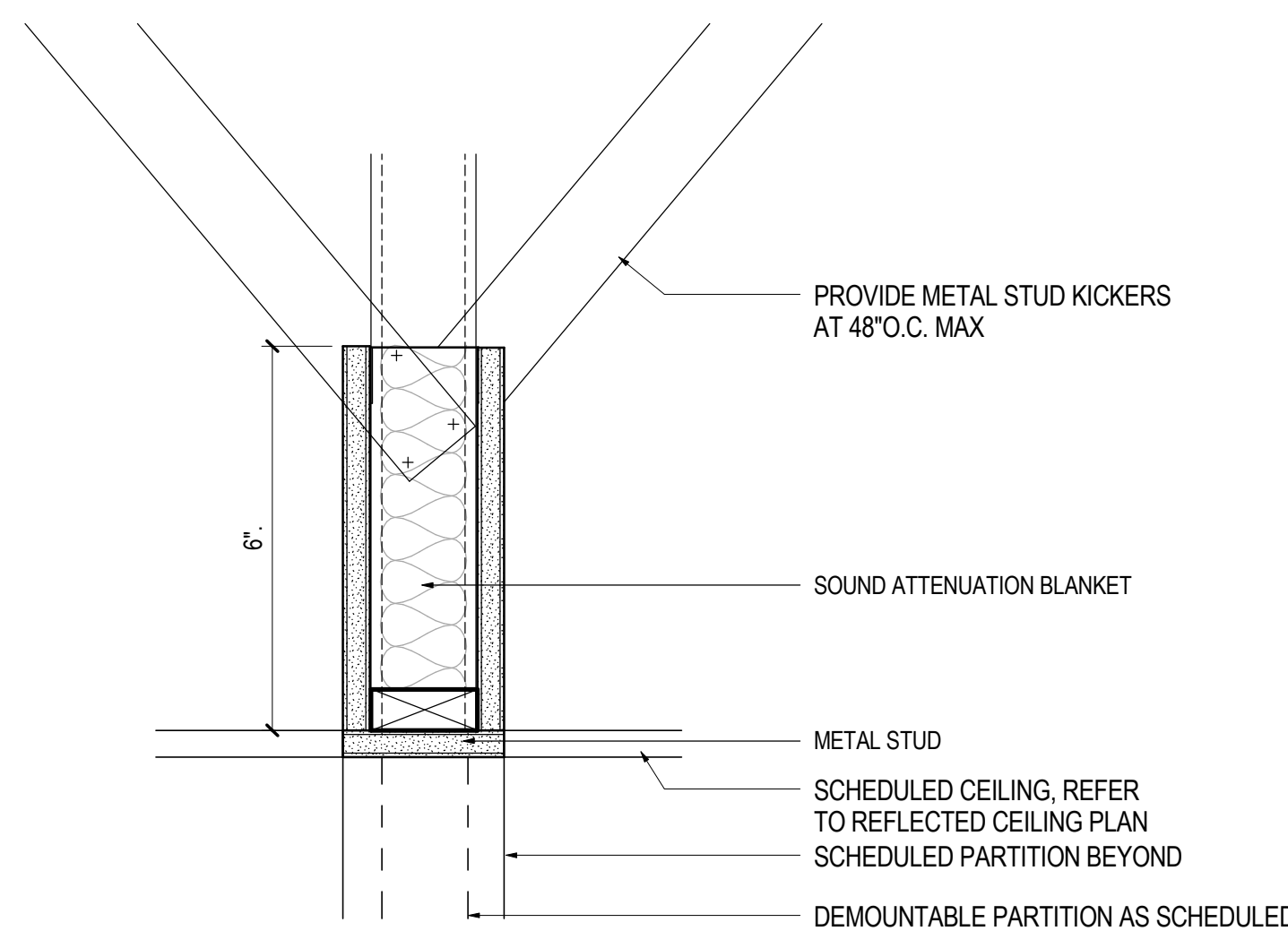

PARTITION HEAD DETAIL Q-T01

SCALE: 3" = 1'-0"

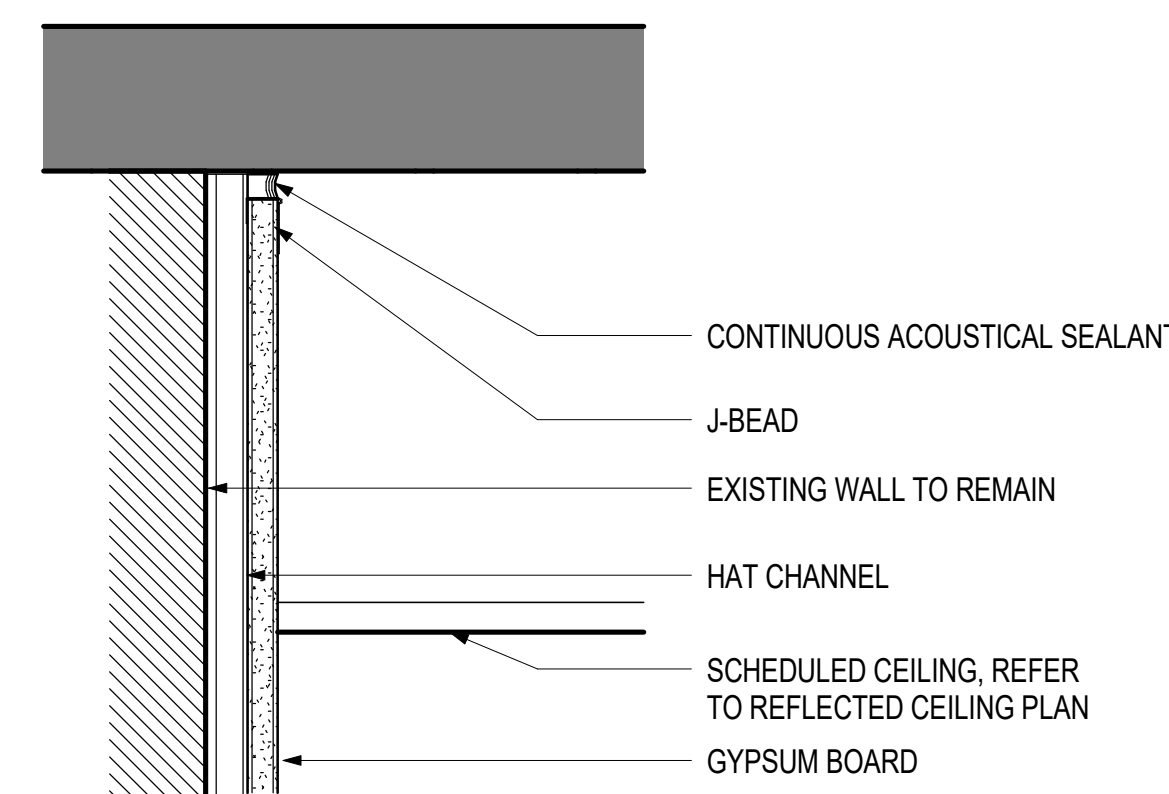

PARTITION HEAD DETAIL F-T04

SCALE: 3" = 1'-0"

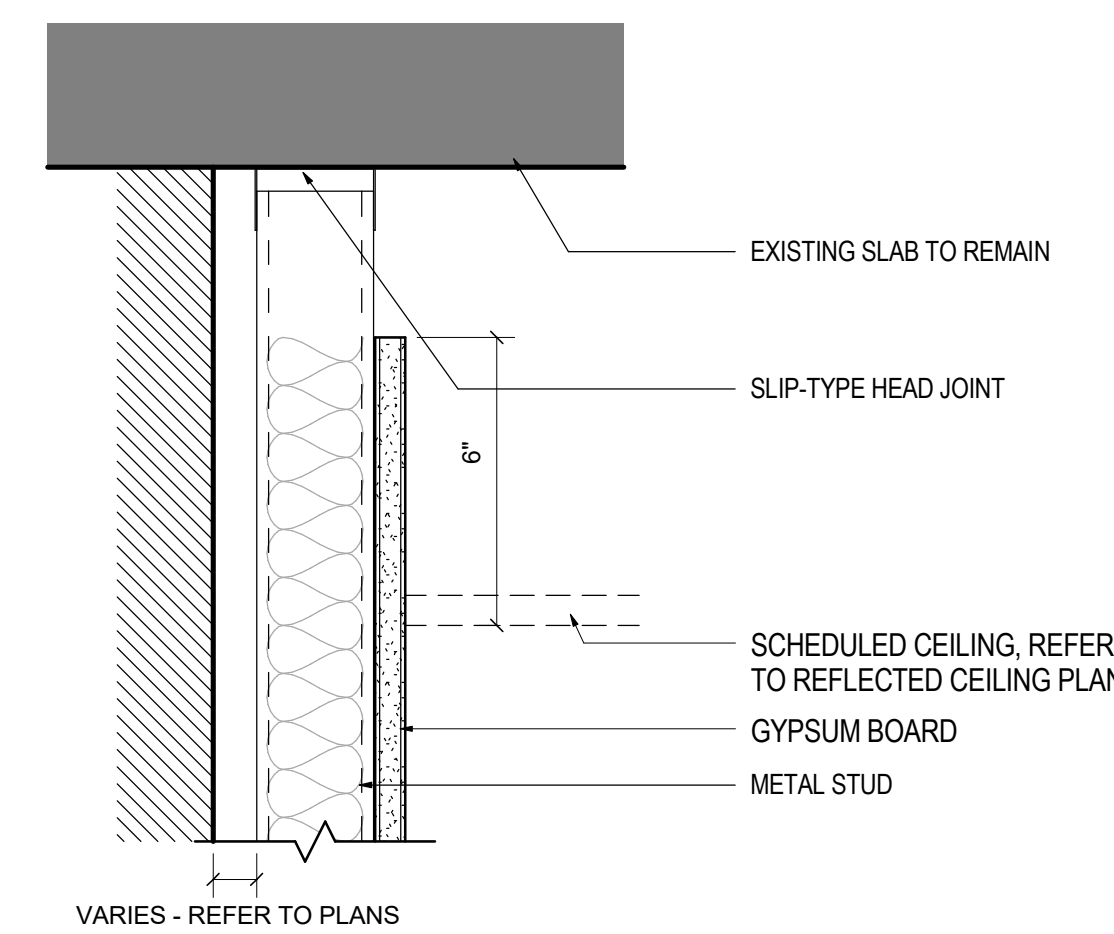

PARTITION HEAD DETAIL D-T01

SCALE: 3" = 1'-0"

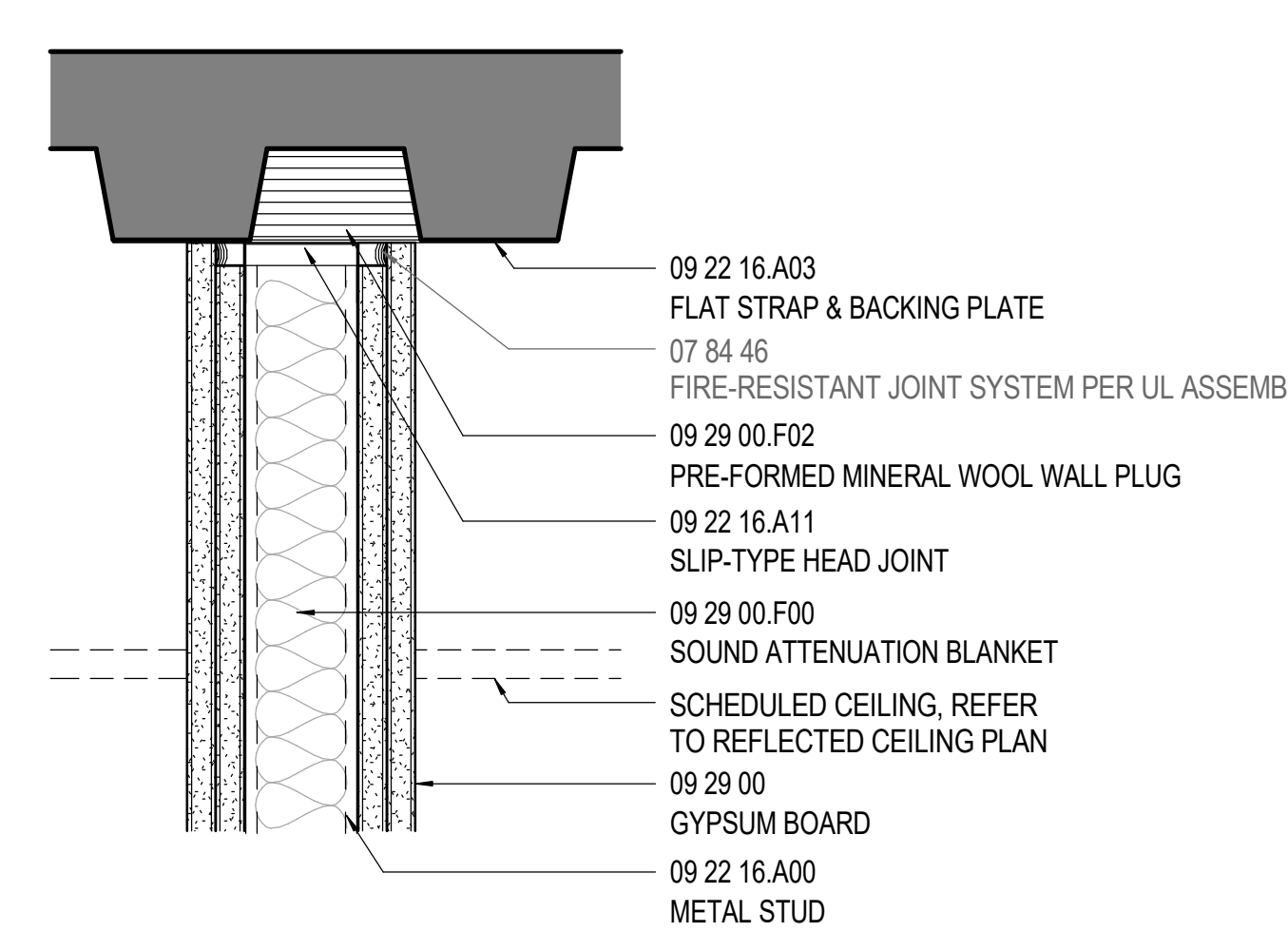

PARTITION HEAD DETAIL B-T01

SCALE: 3" = 1'-0"

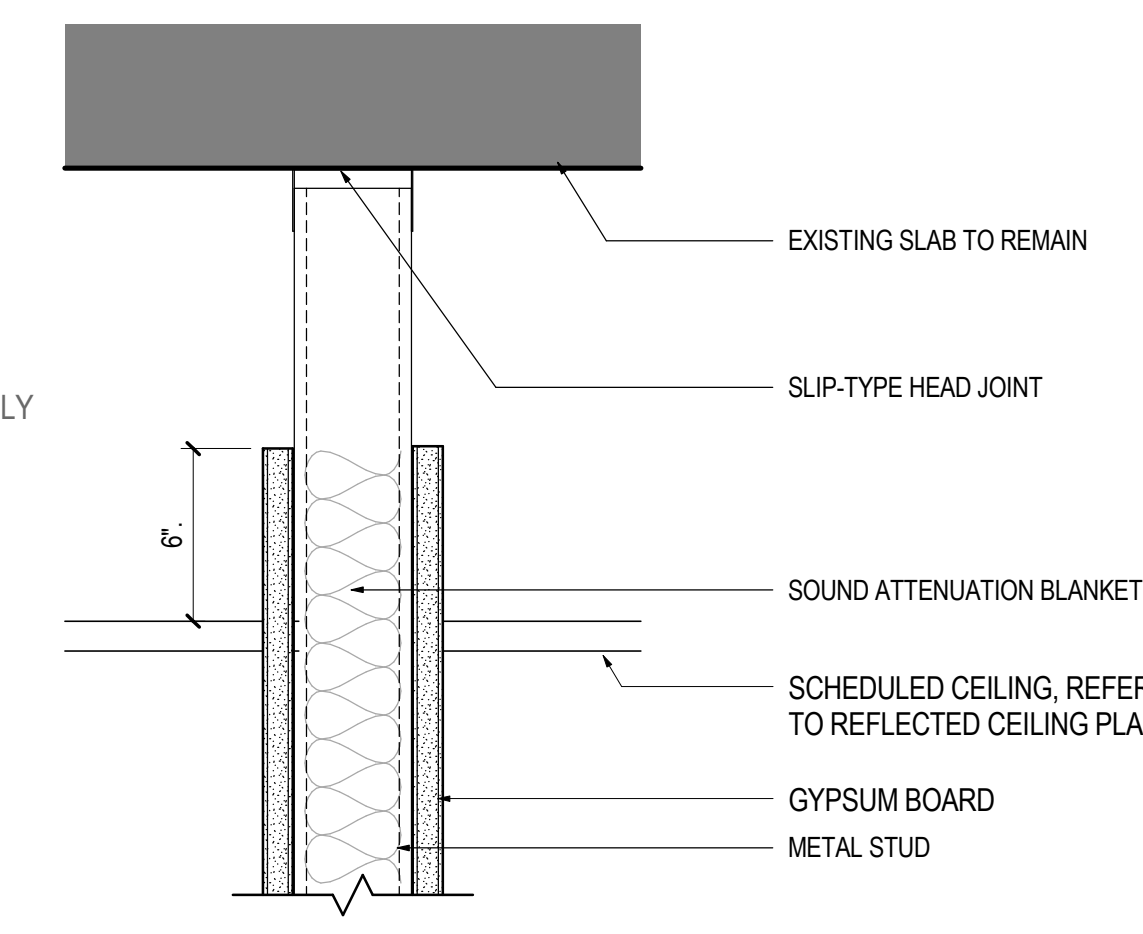

PARTITION HEAD DETAIL A-T02

SCALE: 3" = 1'-0"

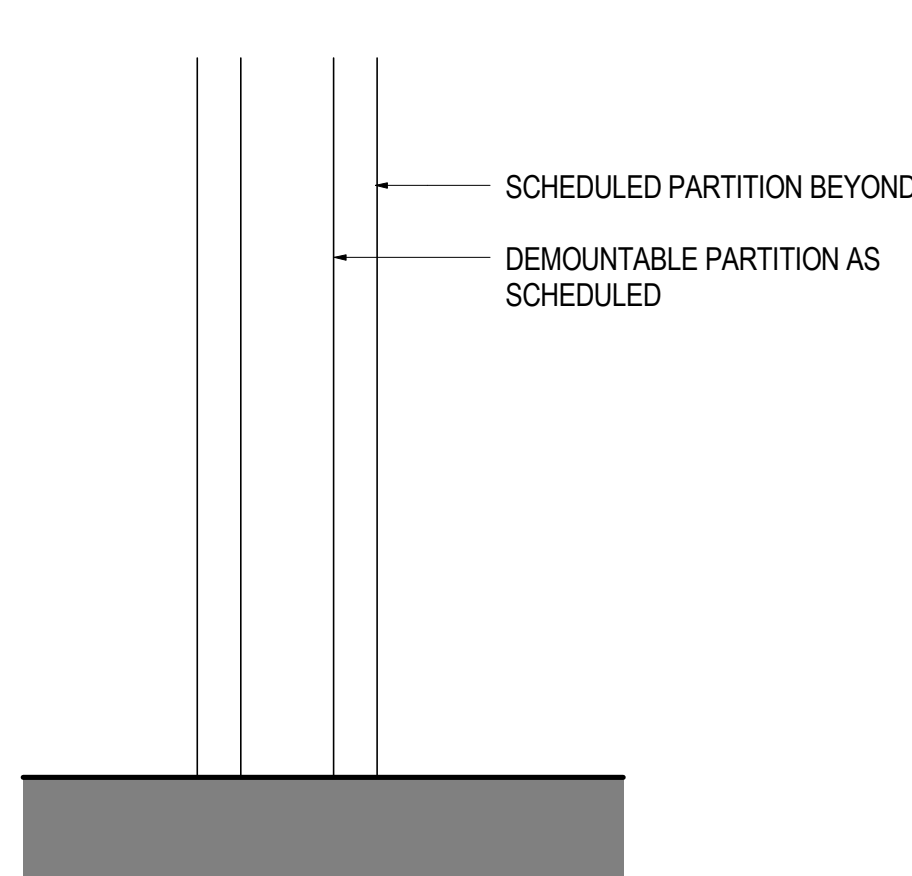

PARTITION BASE DETAIL Q-B01

SCALE: 3" = 1'-0"

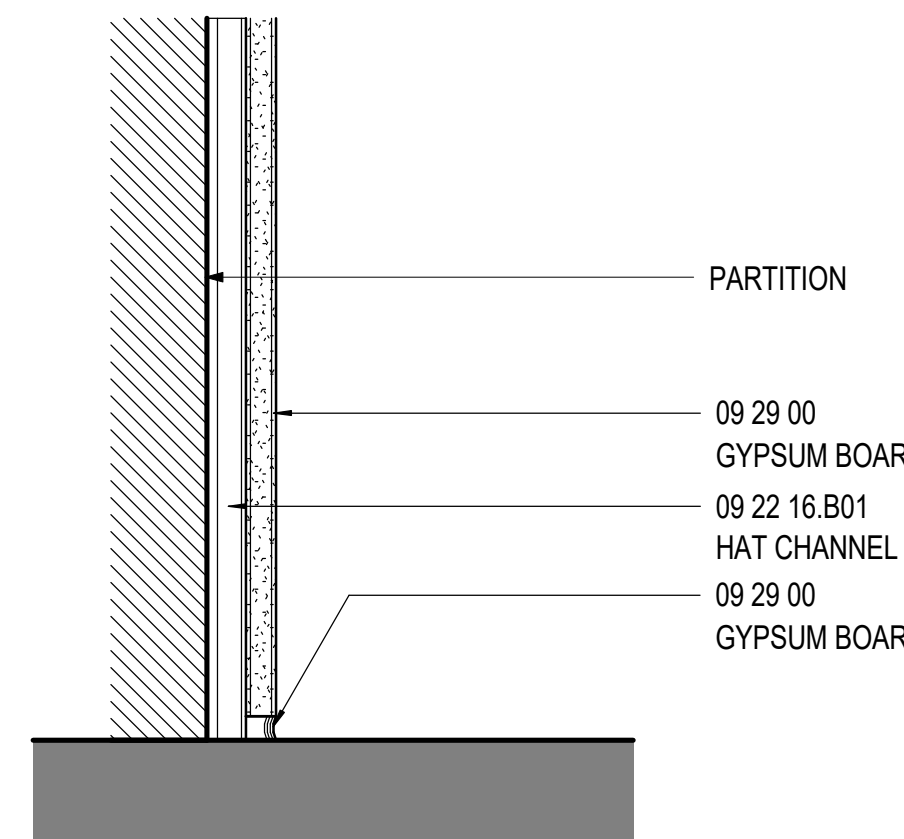

PARTITION BASE DETAIL F-B01

SCALE: 3" = 1'-0"

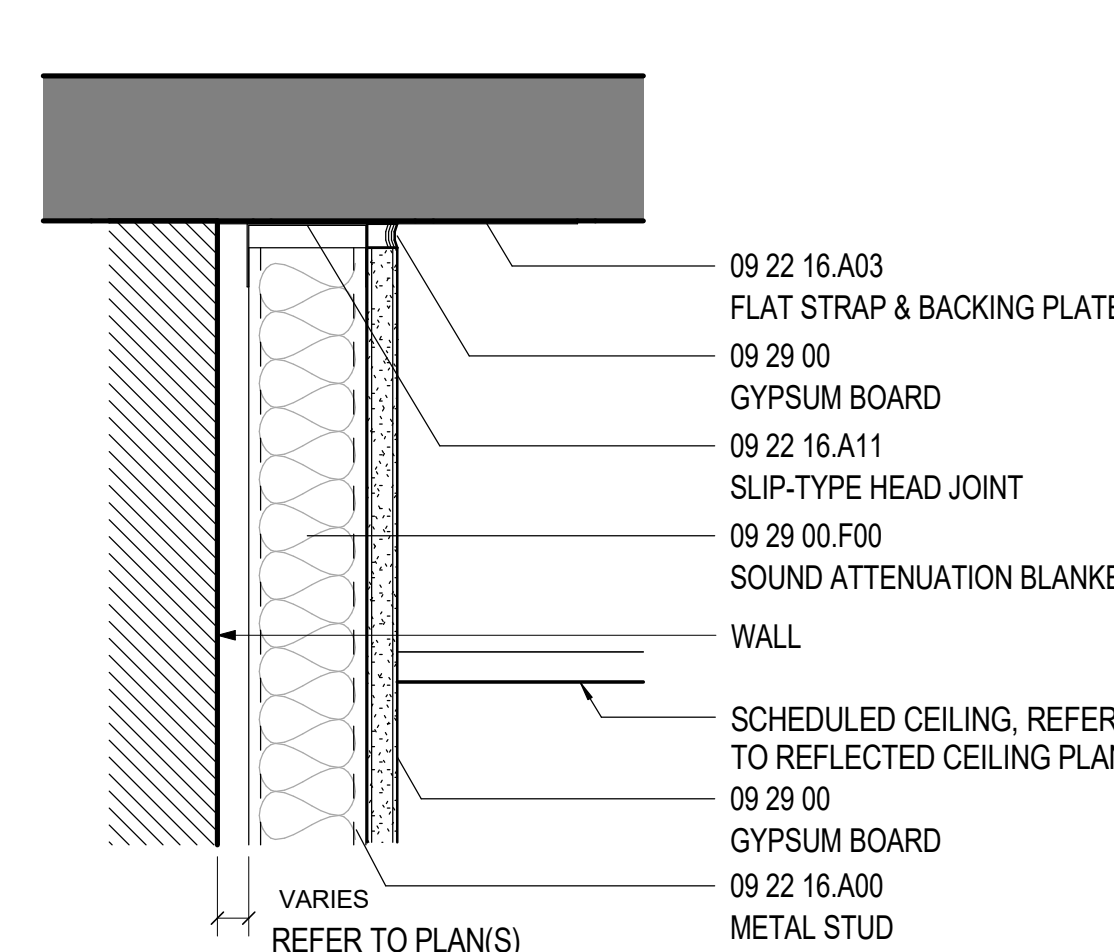

PARTITION HEAD DETAIL D-T04

SCALE: 3" = 1'-0"

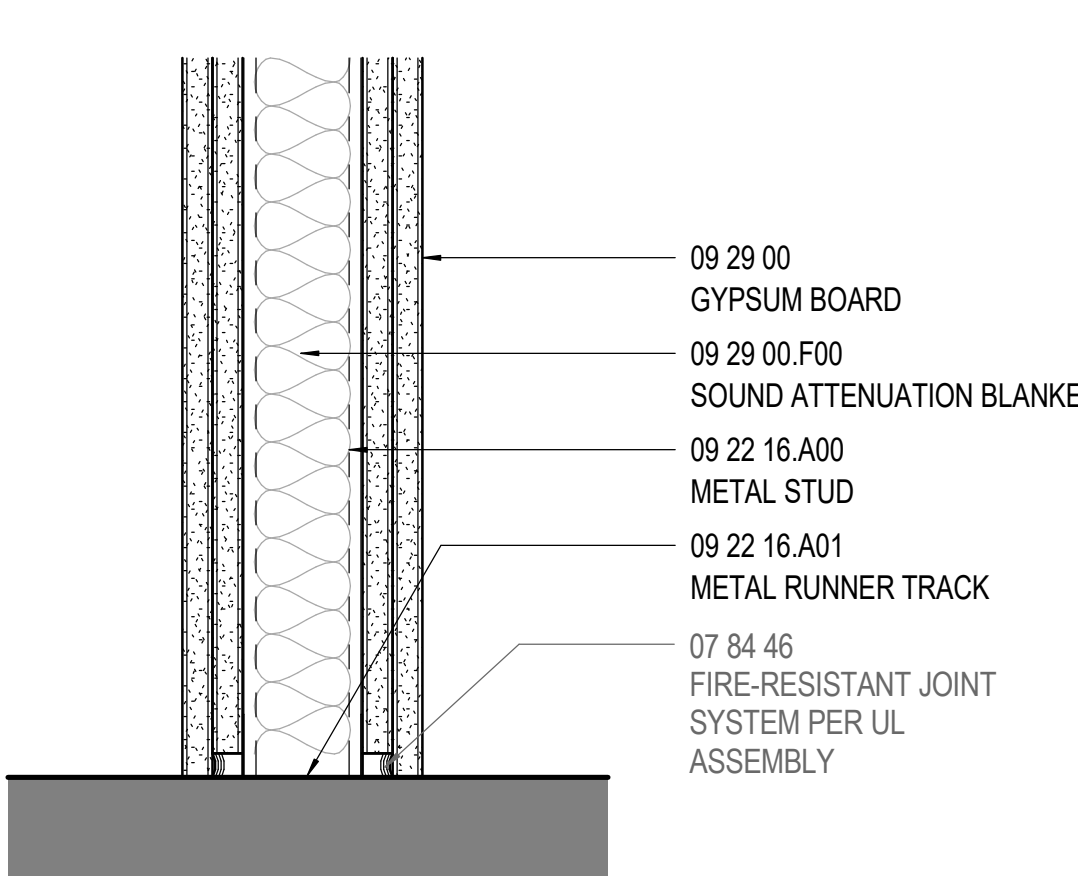

PARTITION BASE DETAIL B-B01

SCALE: 3" = 1'-0"

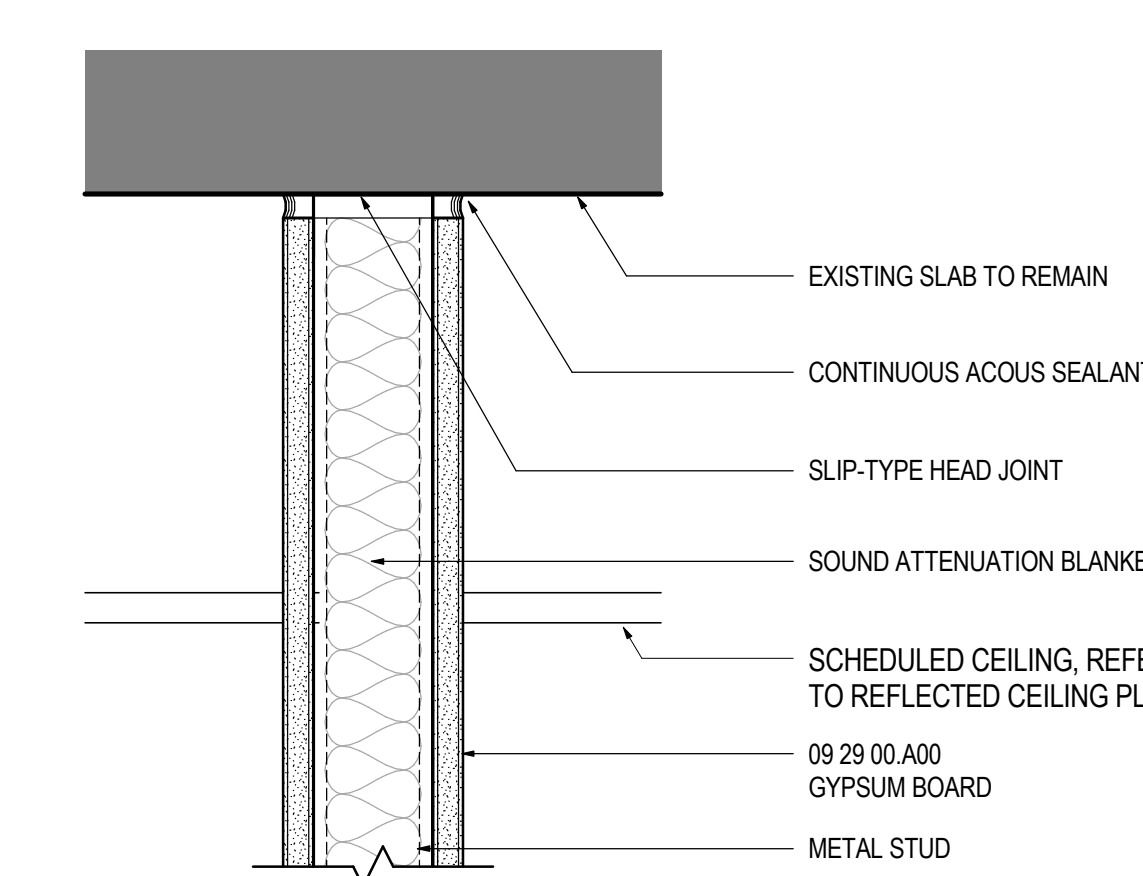

PARTITION HEAD DETAIL A-T04

SCALE: 3" = 1'-0"

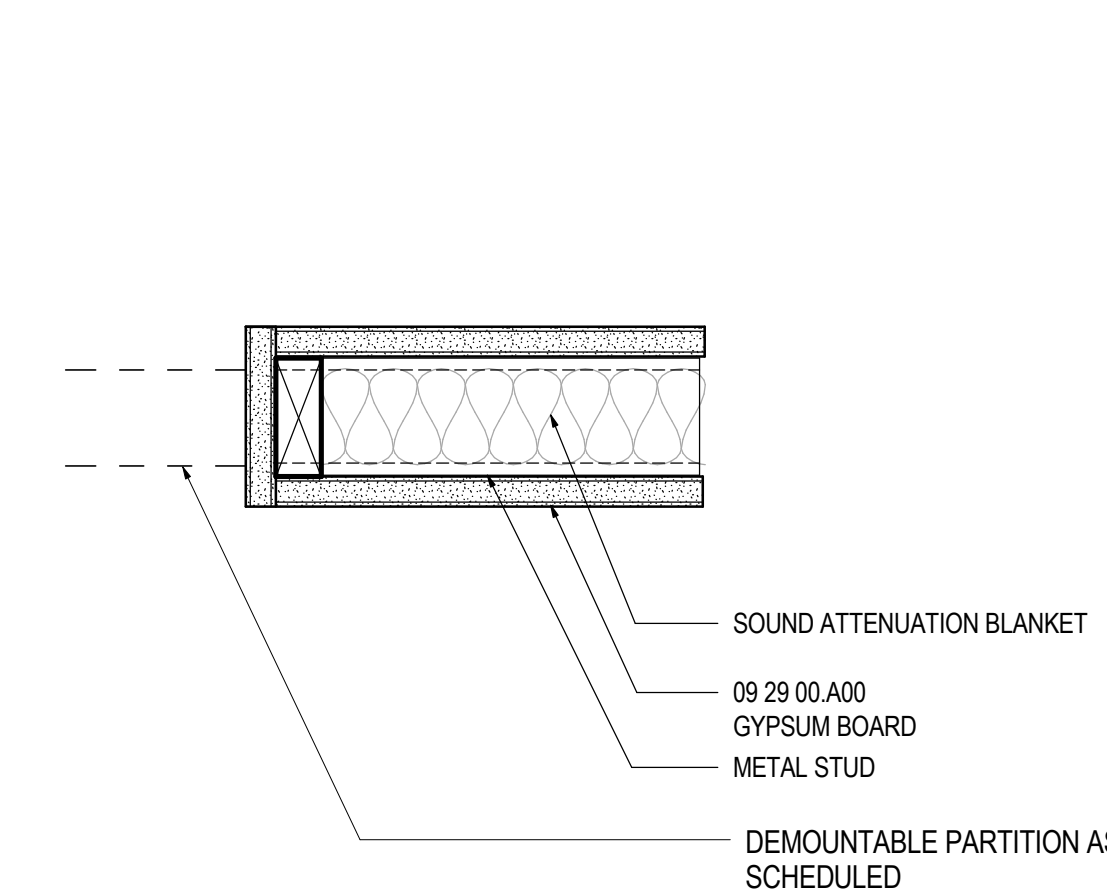

PARTITION JAMB DETAIL Q1

SCALE: 3" = 1'-0"

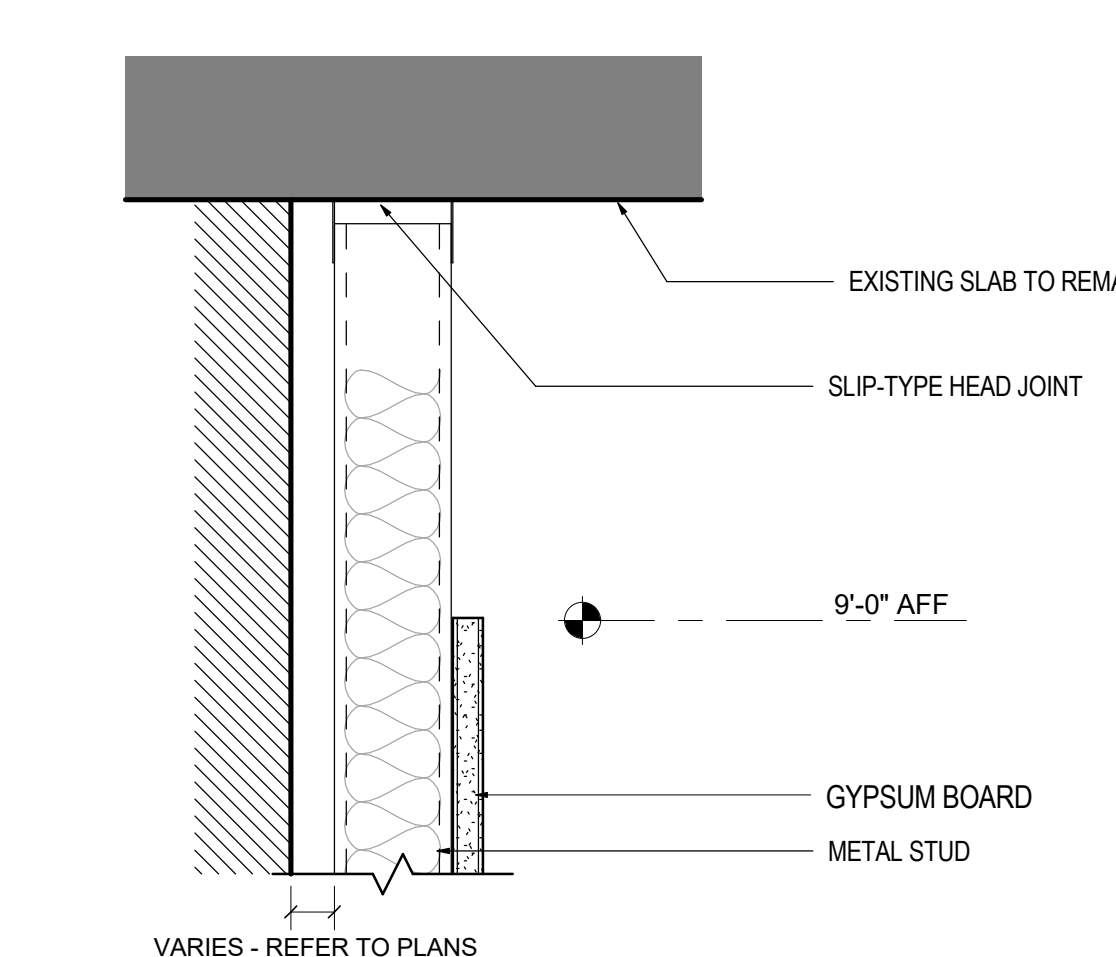

PARTITION HEAD DETAIL D-T05

SCALE: 3" = 1'-0"

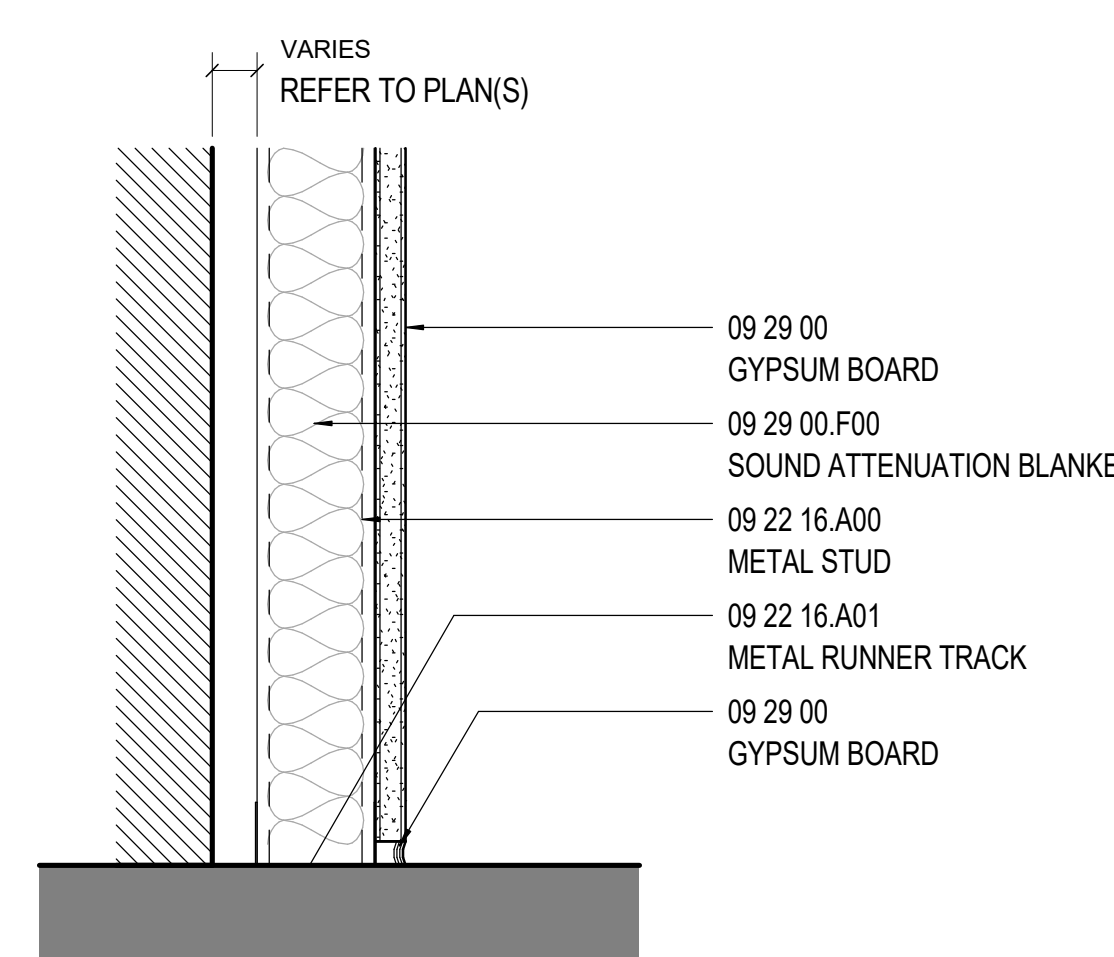

PARTITION BASE DETAIL D-B01

SCALE: 3" = 1'-0"

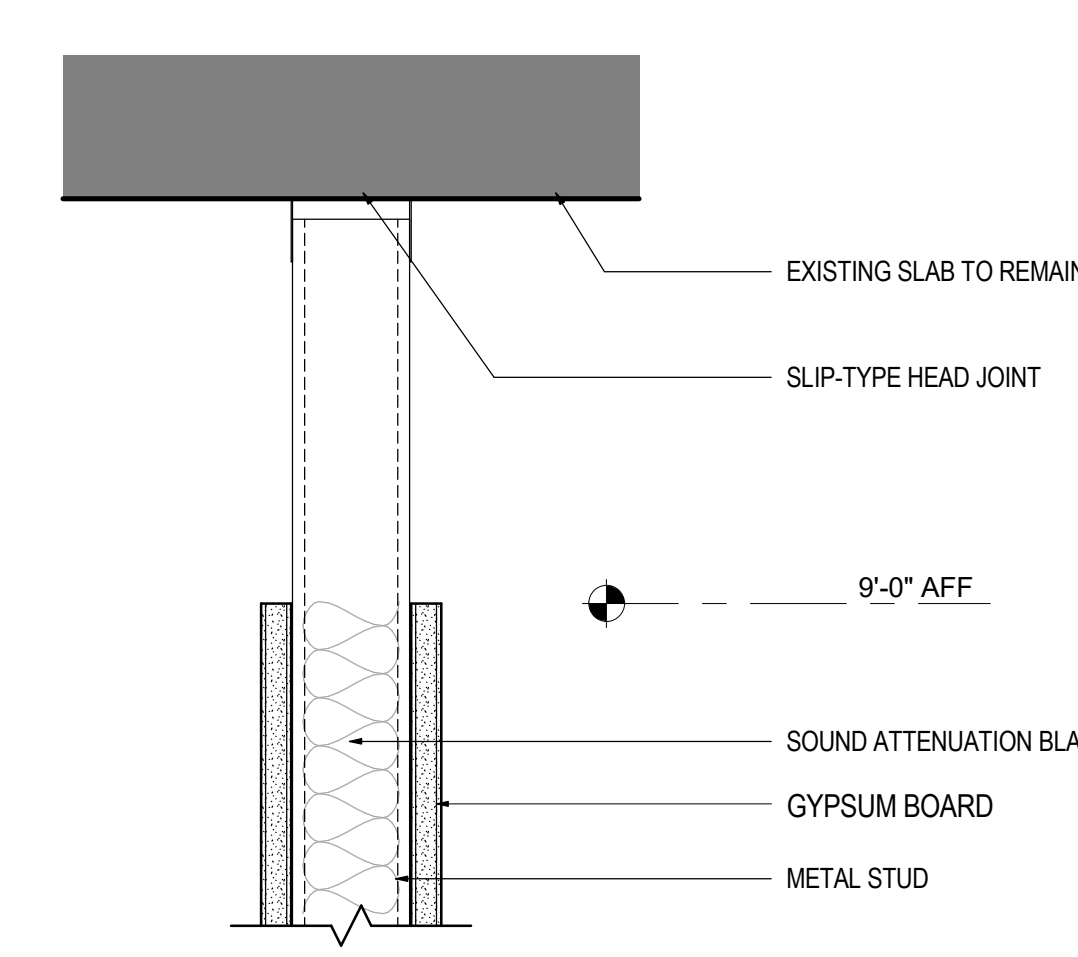

PARTITION HEAD DETAIL A-T05

SCALE: 3" = 1'-0"

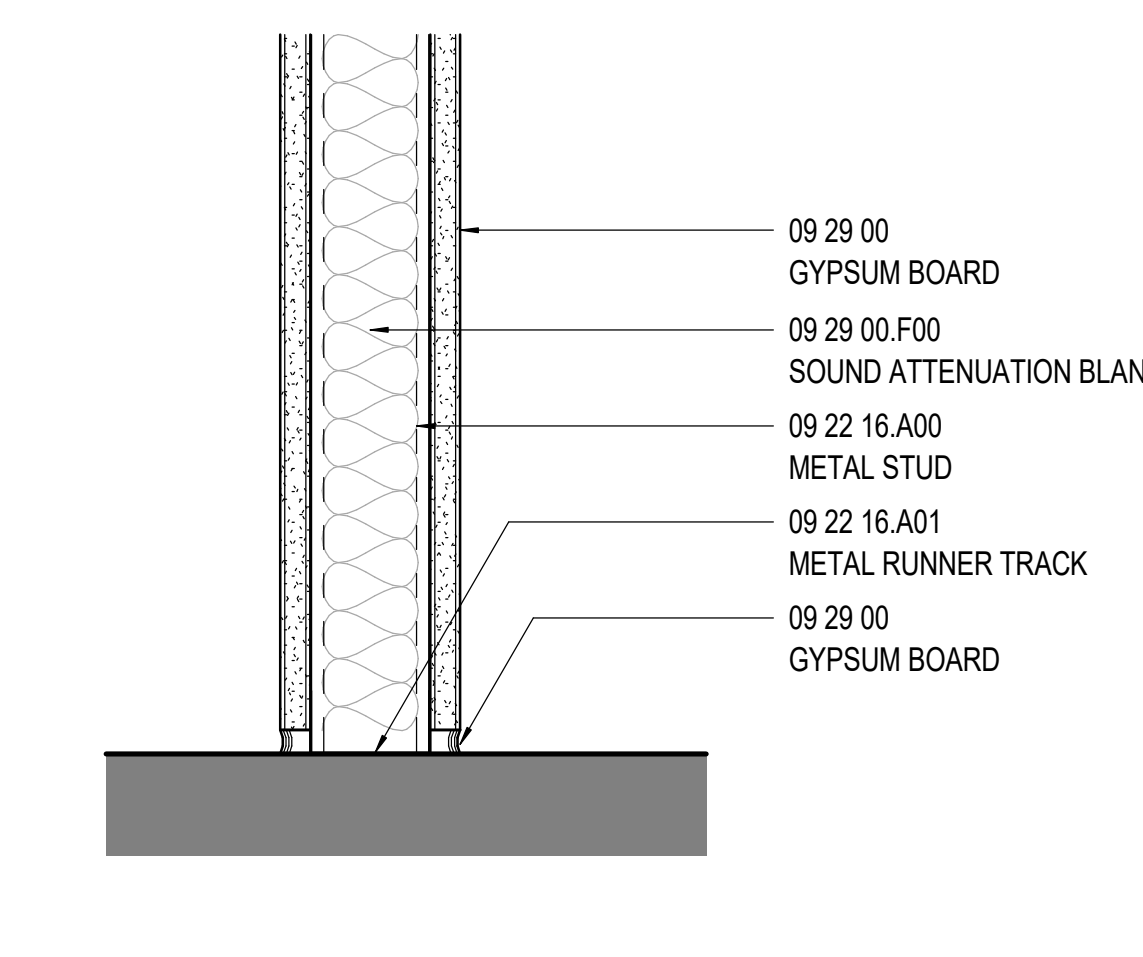

PARTITION BASE DETAIL A-B01

SCALE: 3" = 1'-0"

STUD WALLS BRACING

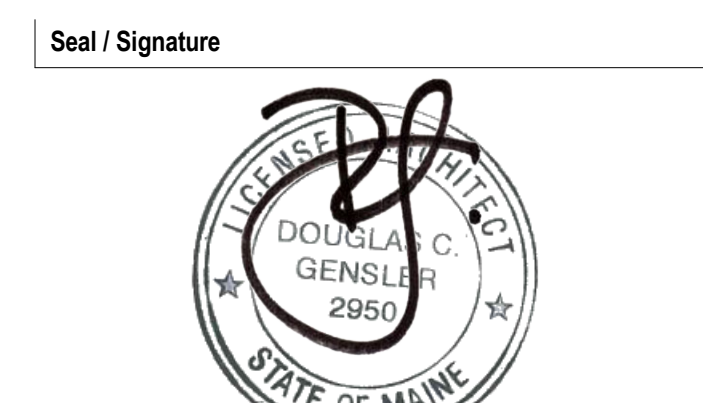
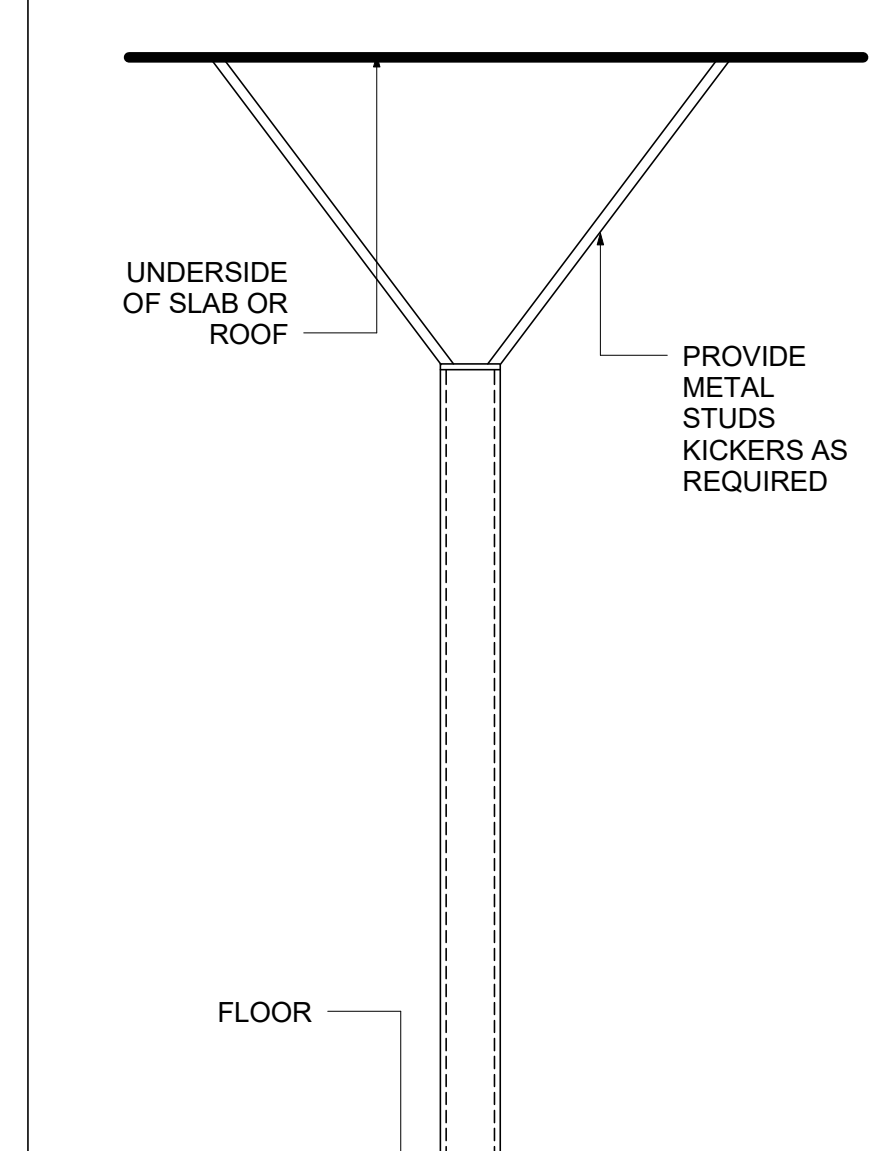

Project Name: Unum Workplace Transformation- Phase 1 (HO2)
 Project Number: 59.6481.003
 Description: PARTITION TYPE DETAILS

Scale: As indicated

A00.010