

DISPLAY THIS CARD ON PRINCIPAL FRONTAGE OF WORK CITY OF PORTLAND

BUILDING INSPECTION

PERMIT

Permit Number. 061181

Please Read
Application And
Notes, If Any,
Attached

This is to certify that EARL APARTMENTS LLC Portland Airconditioning, Inc.

has permission to Install duct for exhaust hood system

AT 28 PREBLE ST

037 F005001

PERMIT ISSUED
OCT - 4 2006
CITY OF PORTLAND

provided that the person or persons who perform or supervise the work accepting this permit shall comply with all of the provisions of the Statutes of the State and of the Ordinances of the City of Portland regulating the construction, maintenance and use of buildings and structures, and of the application on file in this department.

Apply to Public Works for street line and grade if nature of work requires such information.

A certificate of inspection must be obtained and when permission is procured before this building or part thereof is occupied or service is closed-in. **YOUR NOTICE IS REQUIRED.**

A certificate of occupancy must be procured by owner before this building or part thereof is occupied.

OTHER REQUIRED APPROVALS

Fire Dept. _____
Health Dept. _____
Appeal Board _____
Other _____
Department Name

William A. Collins 10/03/06
Director - Building & Inspection Services

PENALTY FOR REMOVING THIS CARD

City of Portland, Maine - Building or Use Permit Application

389 Congress Street, 04101 Tel: (207) 874-8703, Fax: (207) 874-8716

Permit No: 06-1181	Issue Date:	CBL: 037 F005001
-----------------------	-------------	---------------------

Location of Construction: 28 PREBLE ST	Owner Name: EARL APARTMENTS LLC	Owner Address: 104 GRANT ST	Phone:
Business Name:	Contractor Name: Portland Airconditioning, Inc.	Contractor Address: 205 Lincoln St. S. Portland	Phone 2077674567
Lessee/Buyer's Name	Phone:	Permit Type: Hood Systems, Commerical	Zone: B3
Past Use: Commercial - <i>retail</i> <i>restaurant</i> <i>"Down Home Cooking"</i> <i>(takeout sandwich shop)</i>	Proposed Use: Commercial install duct for exhaust hood system	Permit Fee:	Cost of Work: \$11,500.00
Proposed Project Description: Install duct for exhaust hood system		FIRE DEPT: <input type="checkbox"/> Approved <input type="checkbox"/> Denied <i>See Conditions</i>	INSPECTION: Use Group <i>A2</i> Type: <i>HVAC</i> <i>TYPE I HOOD</i> <i>IMC 2003</i>
		Signature: <i>Greg C...</i>	Signature: <i>[Signature]</i> 10/03/06
PEDESTRIAN ACTIVITIES DISTRICT (P.A.D.)			
Action: <input type="checkbox"/> Approved <input type="checkbox"/> Approved w/Conditions <input type="checkbox"/> Denied			
		Signature:	Date:

Permit Taken By: dmartin	Date Applied For: 08/09/2006	Zoning Approval	
-----------------------------	---------------------------------	------------------------	--

<ol style="list-style-type: none"> This permit application does not preclude the Applicant(s) from meeting applicable State and Federal Rules. Building permits do not include plumbing, septic or electrical work. Building permits are void if work is not started within six (6) months of the date of issuance. False information may invalidate a building permit and stop all work.. 	Special Zone or Reviews <input type="checkbox"/> Shoreland <input type="checkbox"/> Wetland <input type="checkbox"/> Flood Zone <input type="checkbox"/> Subdivision <input type="checkbox"/> Site Plan Maj <input type="checkbox"/> Minor <input type="checkbox"/> MM <input type="checkbox"/> <i>OK w/conditions</i> Date: 8/31/06 ABM	Zoning Appeal <input type="checkbox"/> Variance <input type="checkbox"/> Miscellaneous <input type="checkbox"/> Conditional Use <input type="checkbox"/> Interpretation <input type="checkbox"/> Approved <input type="checkbox"/> Denied Date:	Historic Pr ti <input type="checkbox"/> Not in District or Landmark <input type="checkbox"/> Docs Nc Require Review <input type="checkbox"/> q Review <input type="checkbox"/> p <input type="checkbox"/> pproved w/Conditions <input type="checkbox"/> Denied Date:
---	---	---	--

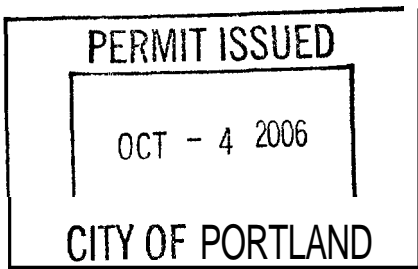

CERTIFICATION

I hereby certify that I am the owner of record of the named property, or that the proposed work is authorized by the owner of record and that I have been authorized by the owner to make this application as his authorized agent and I agree to conform to all applicable laws of this jurisdiction. In addition, if a permit for work described in the application is issued, I certify that the code official's authorized representative shall have the authority to enter all areas covered by such permit at any reasonable hour to enforce the provision of the code(s) applicable to such permit.

SIGNATURE OF APPLICANT ADDRESS DATE PHONE

RESPONSIBLE PERSON IN CHARGE OF WORK, TITLE DATE PHONE

City of Portland, Maine - Building or Use Permit Application

389 Congress Street, 04101 Tel: (207) 874-8703, Fax: (207) 874-8716

Permit No: 06-1181	Issue Date:	CBL: 037 F005001
-----------------------	-------------	---------------------

Location of Construction: 28 PREBLE ST	Owner Name: EARL APARTMENTS LLC	Owner Address: 104 GRANT ST	Phone:
---	------------------------------------	--------------------------------	--------

Business Name:	Contractor Name: Portland Airconditioning, Inc.	Contractor Address: 205 Lincoln St. S. Portland	Phone: 12077674567
----------------	--	--	-----------------------

Lessee/Buyer's Name	Phone:	Permit Type: Hood Systems, Commerical	Zone: B3
---------------------	--------	--	-------------

Past Use: Commercial - <i>retail</i> <i>restaurant</i> <i>"Down Home Cooking"</i> <i>(takeout sandwich shop)</i>	Proposed Use: Commercial install duct for exhaust hood system	Permit Fee:	Cost of Work: \$1,500.00	CEO District: 1
--	--	-------------	-----------------------------	--------------------

FIRE DEPT: <input type="checkbox"/> Approved <input type="checkbox"/> Denied <i>Conditions</i>	INSPECTION: Use Group <i>A2</i> Type <i>HVAC</i> <i>TYPE I HOOD</i> <i>INC 2003</i>
Signature <i>Greg Carr</i>	Signature <i>[Signature]</i> <i>12/03/06</i>

Proposed Project Description:
Install duct for exhaust hood system

PEDESTRIAN ACTIVITIES DISTRICT (P.A.D.)

Action: Approved Approved w/Conditions Denied

Signature: _____ Date: _____

Permit Taken By: dmartin	Date Applied For: 08/09/2006	Zoning Approval
-----------------------------	---------------------------------	------------------------

Special Zone or Reviews	Zoning Appeal	Historic Preservation
<input type="checkbox"/> Shoreland	<input type="checkbox"/> Variance	<input type="checkbox"/> Not in District or Landmark
<input type="checkbox"/> Wetland	<input type="checkbox"/> Miscellaneous	<input type="checkbox"/> Does Not Require Review
<input type="checkbox"/> Flood Zone	<input type="checkbox"/> Conditional Use	<input type="checkbox"/> Requires Review
<input type="checkbox"/> Subdivision	<input type="checkbox"/> Interpretation	<input type="checkbox"/> Approved
<input type="checkbox"/> Site Plan	<input type="checkbox"/> Approved	<input type="checkbox"/> Approved w/Conditions
Maj <input type="checkbox"/> Minor <input type="checkbox"/> MM <input type="checkbox"/>	<input type="checkbox"/> Denied	<input type="checkbox"/> Denied
<i>OK w/ conditions</i> Date: <i>8/31/06</i> <i>ABM</i>	Date: _____	Date: _____

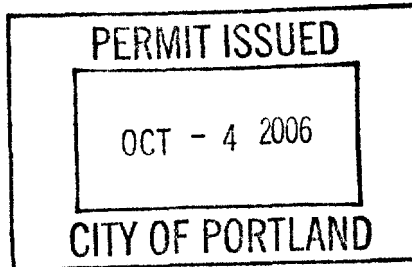

CERTIFICATION

I hereby certify that I am the owner of record of the named property, or that the proposed work is authorized by the owner of record and that I have been authorized by the owner to make this application as his authorized agent and I agree to conform to all applicable laws of this jurisdiction. In addition, if a permit for work described in the application is issued, I certify that the code official's authorized representative shall have the authority to enter all areas covered by such permit at any reasonable hour to enforce the provision of the code(s) applicable to such permit.

SIGNATURE OF APPLICANT	ADDRESS	DATE	PHONE
RESPONSIBLE PERSON IN CHARGE OF WORK, TITLE		DATE	PHONE

Please call 874-8703 or 874-8693 to schedule your inspections as agreed upon

Permits expire in 6 months, if the project is not started or ceases for 6 months,

The Owner or their designee is required to notify the inspections office for the following inspections and provide adequate notice, Notice **must** be called in 48-72 hours in advance in order to schedule an inspection:

By initialzing at each inspection time, you are agreeing that you understand the inspection procedure and additional fees from a "Stop Work Order" and "Stop Work Order Release" will be incurred if the procedure is not followed as stated below,

A Pre-construction Meeting will take place upon receipt of your building permit.

- _____ Footing/Building Location Inspection: Prior to pouring concrete
- _____ Re-Bar Schedule Inspection: Prior to pouring concrete
- _____ Foundation Inspection: Prior to placing ANY backfill
- _____ Framing/Rough Plumbing/Electrical: Prior to any insulating or drywalling
- _____ Final/Certificate of Occupancy: Prior to any occupancy of the structure or use. NOTE: There is a \$75.00 fee per inspection at this point.

Certificate of Occupancy is not required for certain projects, Your inspector can advise you if your project requires a Certificate of Occupancy. All projects DO require a final inspection

REG If any of the inspections do not occur, the project cannot go on to the next phase, **REGARDLESS OF THE NOTICE OR CIRCUMSTANCES.**

NA CERTIFICATE OF OCCUPANCIES MUST BE ISSUED AND PAID FOR, BEFORE THE SPACE MAY BE OCCUPIED

Becker _____
Signature of Applicant/Designee

Date

Signature of Inspections Official

Date 10-4-06

CBL: 37 E

Building Permit #: 06-1181

City of Portland, Maine - Building or Use Permit

389 Congress Street, 04101 Tel: (207) 874-8703, Fax: (207) 874-8716

Permit No: 06-I181	Date Applied For: 08/09/2006	CBL: 037 F005001
------------------------------	--	----------------------------

Location of Construction: 28 PREBLE ST	Owner Name: EARL APARTMENTS LLC	Owner Address: 104 GRANT ST	Phone:
--	---	---------------------------------------	---------------

Business Name:	Contractor Name: Portland Airconditioning, Inc.	Contractor Address: 205 Lincoln St. S. Portland	Phone: (207) 767-4567
-----------------------	---	---	---------------------------------

Applicant/Owner/Buyer's Name	Phone:	Permit Type: Hood Systems, Commercial
-------------------------------------	---------------	---

Proposed Use: Commercial install duct for exhaust hood system	Proposed Project Description: Install duct for exhaust hood system
---	--

Dept: Zoning	Status: Approved with Conditions	Reviewer: Ann Machado	Approval Date: 08/31/2006
Note:	Ok to Issue: <input checked="" type="checkbox"/>		
1) This permit is being approved on the basis of plans submitted. Any deviations shall require a separate approval before starting that work.			

Dept: Building	Status: Approved with Conditions	Reviewer: Mike Collins	Approval Date: 10/03/2006
Note:	Ok to Issue: <input checked="" type="checkbox"/>		
Hold permit. Need stamped/signed structural drawings and kitchen exhaust checklist filed out. Called Portland Air on 08/31/06. Left message with Cathy to re-submit proper paperwork and drawings.			
1) Equipment must be installed in compliance with the manufacturer's specifications			
2) Separate permits are required for any electrical, plumbing, or HVAC systems. Separate plans may need to be submitted for approval as a part of this process.			

Dept: Fire	Status: Approved with Conditions	Reviewer: Cptn Greg Cass	Approval Date: 08/22/2006
Note:	Ok to Issue: <input type="checkbox"/>		
1) Details required for construction of 2 hr. Rated shaft.			
2) need required clean out locations for duct work shown on plan.			
3) NFPA 96 compliance required			

Comments:
8/23/2006-mjn: Left message, inadequate plans, no checklist etc.
8/28/2006-ldobson: Additional information received and routed to MJN
8/17/2006-mjn: advised applicant that we require better job specific plans.



General Building Permit Application

If you or the property owner owes real estate or personal property taxes or user charges on any property within the City, payment arrangements must be made before permits of any kind are accepted.

Location/Address of Construction: <u>28 Preble Street Portland Maine</u>		
Total Square Footage of Proposed Structure <u>2,962</u>	Square Footage of Lot <u>8652</u>	
Tax Assessor's Chart, Block & Lot Chart# <u>37 F 005</u> Block# Lot#	Owner: <u>Port Property Management</u>	Telephone: <u>761-0832</u>
Lessee/Buyer's Name (If Applicable) <u>Down Home Cookin'</u>	Applicant name, address & telephone: <u>Portland Airconditioning Inc 40 Manson Libby Road Scarborough, ME 04054</u>	Cost Of Work: \$ <u>11,500</u> Fee: \$ <u>140.00</u> C of O Fee: \$
Current Specific use: <u>Vacant</u> If vacant, what was the previous use? <u>Wine Store</u> Proposed Specific use: <u>take out sandwich shop/caterer</u> Project description: <u>install duct for exhaust hood system</u>		
Contractor's name, address & telephone: <u>Portland Airconditioning Inc</u> Who should we contact when the permit is ready: <u>Office</u> Mailing address: Phone: <u>207 8851256</u>		

Please submit all of the information outlined in the Commercial Application Checklist. Failure to do so will result in the automatic denial of your permit.

In order to be sure the City fully understands the full scope of the project, the Planning and Development Department may request additional information prior to the issuance of a permit. For further information visit us on-line at www.portlandmaine.gov, stop by the Building Inspections office, room 315 City Hall or call 874-8703.

I hereby certify that I am the Owner of record of the named property, or that the owner of record authorizes the proposed work and that I have been authorized by the owner to make this application as his/her authorized agent. I agree to conform to all applicable laws of this jurisdiction. In addition, if a permit for work described in this application is issued, I certify that the Code Official's authorized representative shall have the authority to enter all areas covered by this permit at any reasonable hour to enforce the provisions of the codes applicable to this permit.

Signature of applicant: <u>[Signature]</u>	Date: <u>08/09/06</u>
--	-----------------------

This is not a permit; you may not commence ANY work until the permit is issued.



Catalog No. 397 (PDF) Search Keyword(s)

LOG IN

User ID

Password



Remember my login ?

Search for Repair Parts

You searched > 3gy73

Results Displayed: 1 - 12 of 12

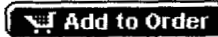

Sort Table By: Default

Search Results

12 Product

Search Again

Keyword(s)



or



Charlie I did not order because pitched roof and not fasteners.
 Over 30,000 fasteners now available online. Learn more

Item #	Qty.	Notes	Description	Brand	Model #	Usually Ships**	Price
X 3GY73		<input checked="" type="checkbox"/>	Exhaust Ventilator, Centrifugal Upblast Assembled, CFM @ 0.000-In SP 8431, @ 0.500-In SP 7536, @ 1.500-In SP 4324, CFM Range 4300 to 8430, Roof Mounting	DAYTON	3GY73	1 Today	\$1,482.00
X 4HX78			Grease Collector Box, Large, Length 24 In, Width 7 In, Height 5 In, Required For NFPA 96 And UL 762 Cooking Applications, Use With Dayton Ventilators 3GY73,	DAYTON	4HX78	1 Today	\$75.85
<input type="checkbox"/> 4C455		<input type="checkbox"/>	Roof Curb, Adjustable, Nonventilated, Outside Square 32 1/2 to 41 In, Curb Height 6 3/8 In, 18 Gauge Galvanized Steel Construction, For General Ventilation,	DAYTON	4C455	1 Today	\$238.75
<input type="checkbox"/> 1RL34			Grease Collector Box, Small, Length 14 In, Width 5 In, Height 4 In, Required For NFPA 96 And UL 762 Cooking Applications, Use With Dayton Ventilators 3GY73,	DAYTON	1RL34	1 Today	\$47.10
<input type="checkbox"/> 3C438		<input checked="" type="checkbox"/>	Roof Curb, Adjustable, Nonventilated, Outside Square 32 1/2 to 41 In, Curb Height 12 3/8 In, 18 Gauge Galvanized Steel Construction, For General Ventilation,	DAYTON	3C438	1 Today	\$314.25
<input type="checkbox"/> 4HX42		<input checked="" type="checkbox"/>	Roof Curb, Fixed, Nonventilated, Inside Square 29 1/2 In, Outside Square 32 1/2 In, Curb Height 8 In, 18 Gauge Galvanized Steel	DAYTON	4HX42	1 Today	\$180.75

EXHAUST SYSTEM GENERAL NOTES:

1. Hood contractor shall coordinate installation with other trades
2. All ductwork is shown diagrammatically. Exact locations are to be determined in the field.
3. All duct sizes shown are outside dimensions.
4. Wire fire alarm system to automatically shut off all sources of fuel and heat for appliances under the hood.
5. Maintain minimum 1,500 FPM air velocity in hood exhaust ducts.
6. Hood exhaust duct insulation: Apply Fire Master Commercial Duct Wrap to maintain 0" clearance to combustibles.
7. Hood **fire** extinguishing system to be Ansul system
8. Tempered makeup air from ducted furnace system supplying outside air and louver with motor operated damper interconnected with hood exhaust fan wired to open whenever exhaust is activated.
9. Exhaust duct to be 16 gauge black iron welded duct
10. Duct to be hung with **3 x 3 x 1** angle
11. Fire rating to comply with NFPA **96** installation with two stories or more

EXHAUST HOOD SPECIFICATION:

1. Type I single wall type hood with no built-in make-up air capabilities.
2. Hood components shall be fabricated of stainless steel, #3 or #4 polish, on all exposed surfaces.
3. Hood shall be supplied with hanging angles on each end of the hood
4. Hood shall be fitted with a 1" thick removable mesh filters at duct location. Filters shall be easily removable for cleaning purposes.
5. Nominal hood dimensions shall be as shown on drawings.



General Building Permit Application

If you or the property owner owes real estate or personal property taxes or user charges on any property within the City, payment arrangements must be made before permits of any kind are accepted.

Location/Address of Construction: <u>28 Preble Street Portland Maine</u>		
Total Square Footage of Proposed Structure <u>2,962</u>	Square Footage of Lot <u>8652</u>	
Tax Assessor's Chart, Block & Lot Chart# <u>37 F 005</u> Block# Lot#	Owner: <u>Port Property Management</u>	Telephone: <u>761-0832</u>
Lessee/Buyer's Name (If Applicable) <u>Down Home Cookin'</u>	Applicant name, address & telephone: <u>Portland Airconditioning Inc</u> <u>40 Manson Libby Road</u> <u>Scarborough, ME 04074</u>	Cost Of Work: \$ <u>11,500</u> Fee: \$ _____ C of O Fee: \$ _____
Current Specific use: <u>Vacant</u> If vacant, what was the previous use? <u>Wine Store</u> Proposed Specific use: <u>take out sandwich shop/caterer</u>	Project description: <u>install duct for exhaust hood system</u>	
Contractor's name, address & telephone: <u>Portland Airconditioning Inc</u>		
Who should we contact when the permit is ready: <u>Office</u> Mailing address: _____ Phone: <u>207 8851256</u>		

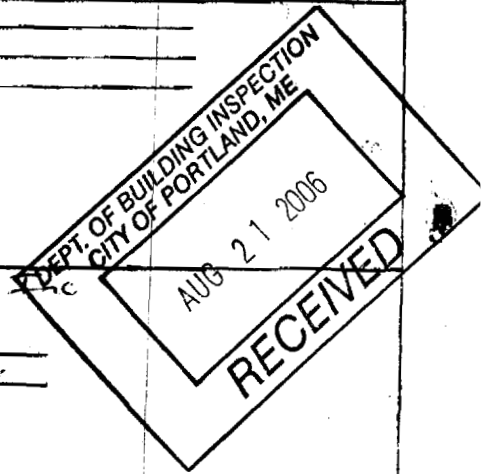

Please submit all of the information outlined in the Commercial Application Checklist. Failure to do so will result in the automatic denial of your permit.

In order to be sure the City fully understands the full scope of the project, the Planning and Development Department may request additional information prior to the issuance of a permit. For further information visit us on-line at www.portlandmaine.gov, stop by the Building Inspections office, room 315 City Hall or call 874-8703.

I hereby certify that I am the Owner of record of the named property, or that the owner of record authorizes the proposed work and that I have been authorized by the owner to make this application as his/her authorized agent. I agree to conform to all applicable laws of this jurisdiction. In addition, if a permit for work described in this application is issued, I certify that the Code Official's authorized representative shall have the authority to enter all areas covered by this permit at any reasonable hour to enforce the provisions of the codes applicable to this permit.

Signature of applicant: [Signature] Date: 08/09/06

This is not a permit; you may not commence ANY work until the permit is issued.

Additional Drawing As Requested by Mike Nugent on 8/17/06

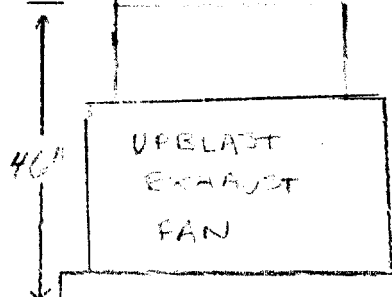

EXHAUST
PIPE

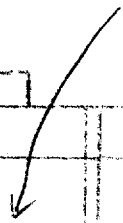

2x3
angle
with
fire
wrap

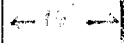

2x3
angle
per
foot

40x20
steel I-beam
wrapped with
3M Fire Master
Wrap

→

INFERENCE ROOM

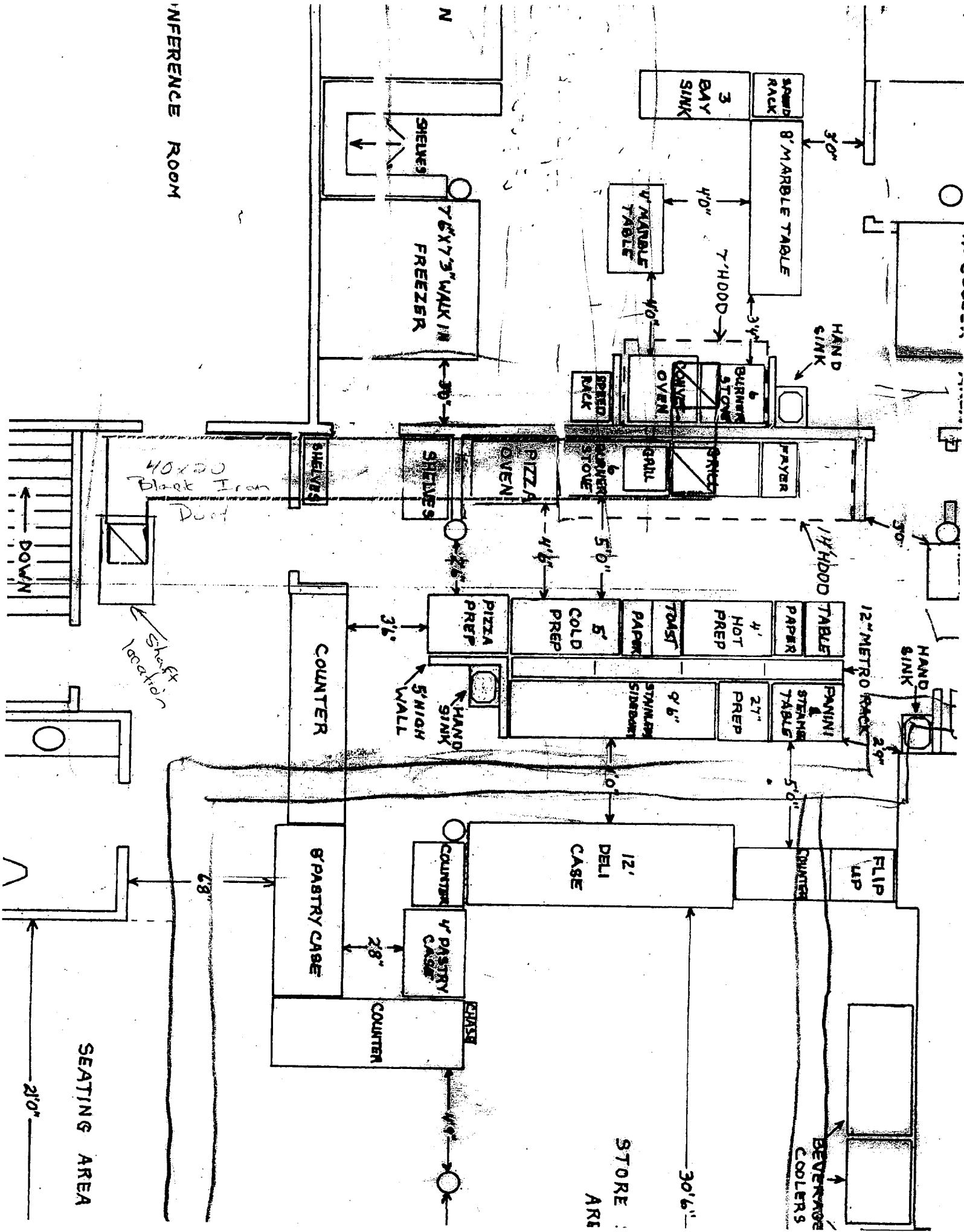

STORE
ARI

BEVERAGE
COOLERS

SEATING AREA

21'0"

28"

28"

30'6"

COUNTER

COUNTER

CASE

COUNTER

6' PASTRY CASE

COUNTER

4" PASTRY CASE

12' DELI CASE

12' FLIP TOP

27" PREP

9'6" PREP

4" HOT PREP

TOAST PAPER

5' COLD PREP

PIZZA OVEN

GRILL

BURNING STOVE

TOASTER OVEN

7" HOOD

8' MARBLE TABLE

30" RACK

3 BAY SINK

7'6" x 7'3" WALK IN FREEZER

SHELVES

SHELVES

40x80 Black Iron Door

Shaft location

DOWN

N

N

INFERENCE ROOM

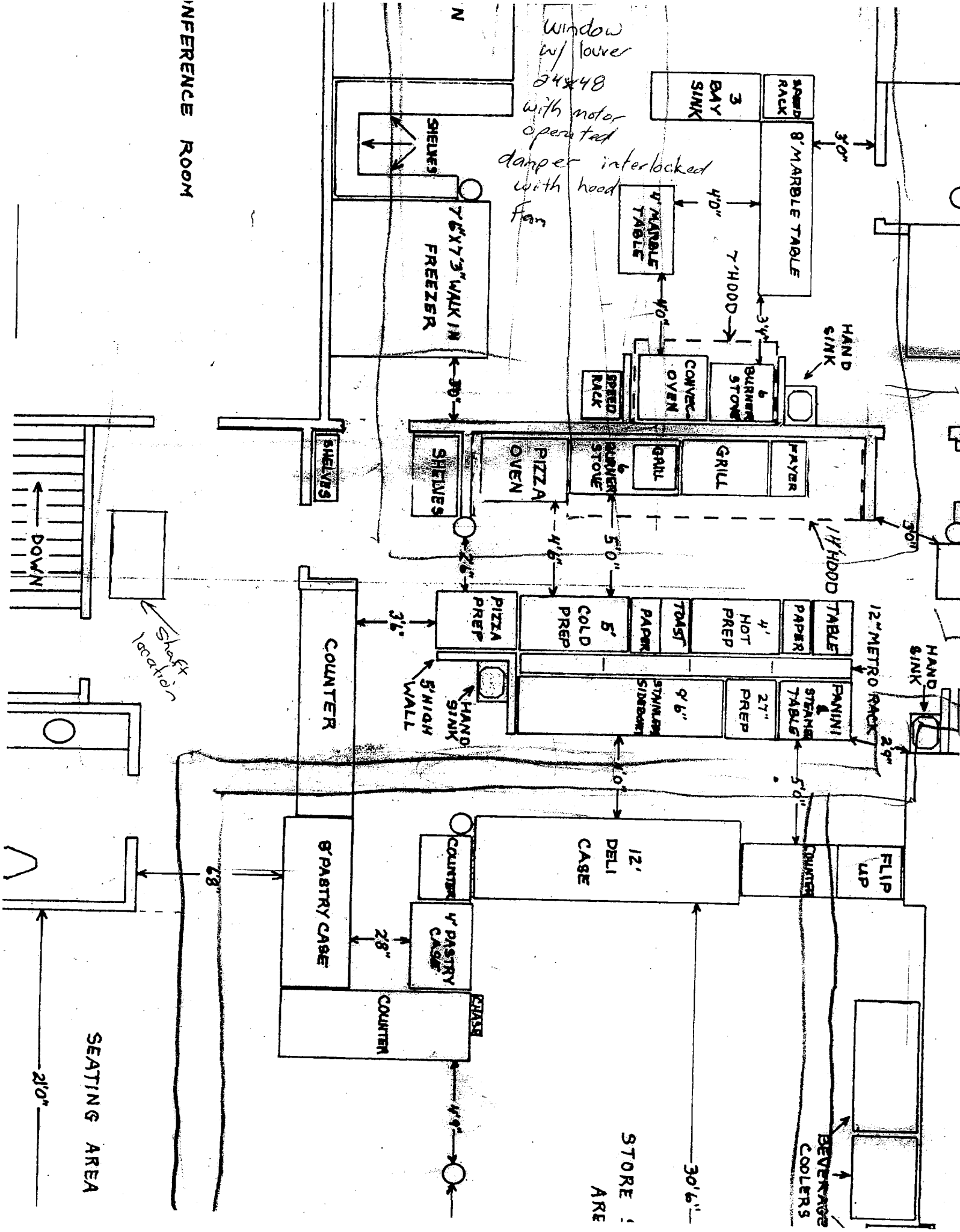

Window w/ louver
24x48
with motor
operated
damper interlocked
with hood
fan

Shaft
location

STORE
AREA

BEVERAGE
COOLERS

SEATING AREA

210"

ANNEX A

96-29

HOME COOKING
28 PREBLE ST
PORTLAND, ME
08-03-06

TO'S
KATHY M.
PORTAIR

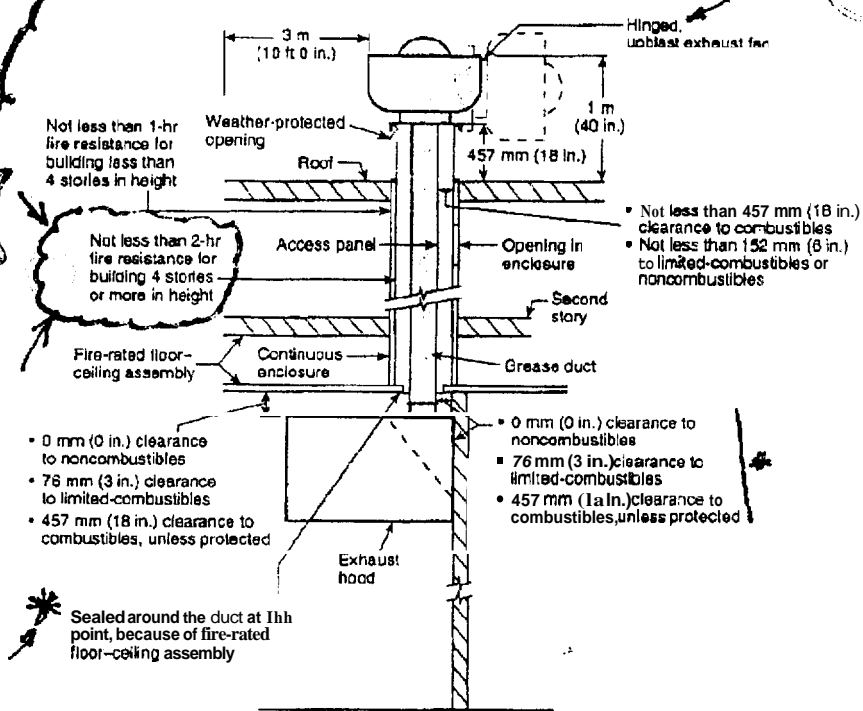
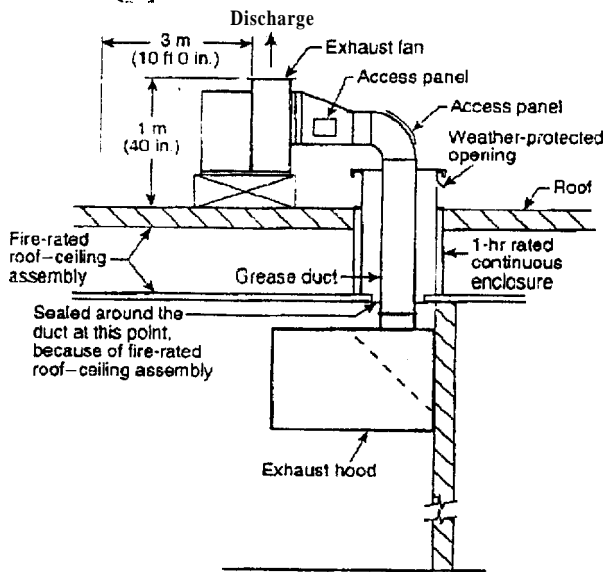
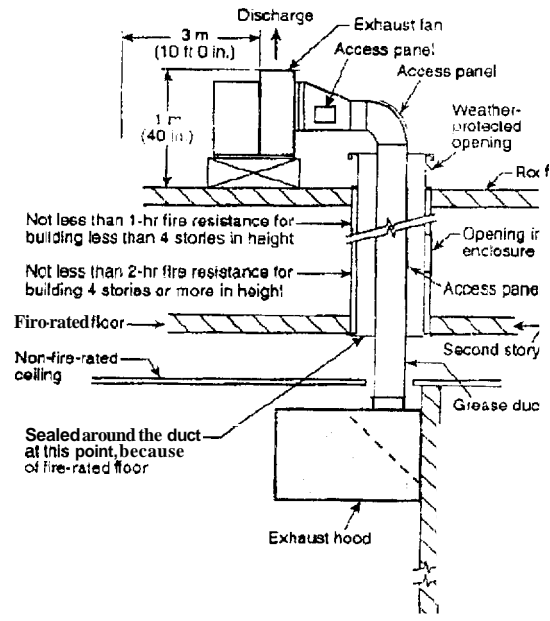

FIGURE A.4.2(a) Typical Section View for Building with Two Stories or More with Fire-Rated Floor-Ceiling Assembly



Note: Clearance notes in Figure A.4.2(a) apply also to this drawing.

FIGURE A.4.2(b) Typical Section View for One-Story Building with Fire-Rated Roof-Ceiling Assembly.



Note: Clearance notes in Figure A.4.2(a) apply also to this drawing.

FIGURE A.4.2(c) Typical Section View for Building with Two Stories or More with Non-Fire-Rated Ceiling and Fire-Rated Floor.

NFPA-96
2004 Edition

P181-

F

Fy 1100 - Vair

Detail

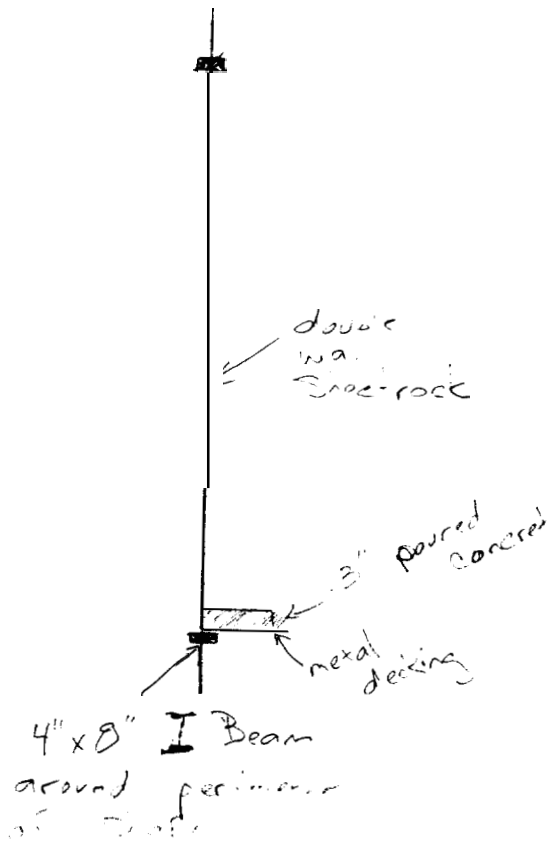

3000-rod / Floor =
40 x 20 / 16 usage =
20 = linear foot =
3000[#] of
door supported
with 2x2 angle
@ shaft cord out

Exhaust - out Location in Shaft (nts)

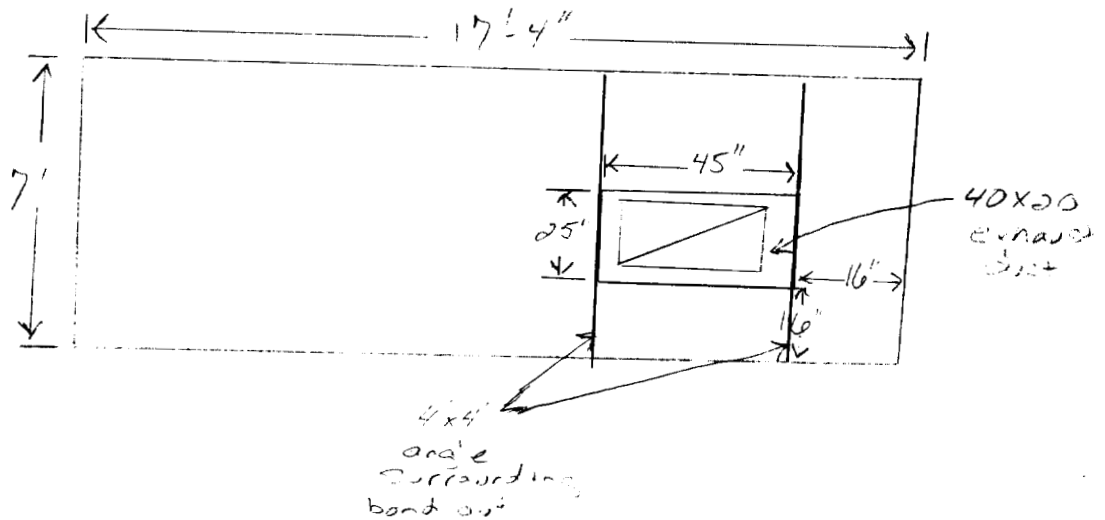



Search

Catalog No. 397 (PDF) Keyword(s)

LOG IN

User ID

Password



Remember my login

Item Details

HVAC > Exhaust Fans > Belt Drive Centrifugal Exhaust Vents

Exhaust Vent, 24 1/2 In

Exhaust Ventilator, Centrifugal Uplast Assembled, CFM @ 0.000-In SP 8431, @ 0.500-In SP 7536, 1,500-In SP 4324, CFM Range 4300 to 8430, Roof Mounting Location, Base Width 34 In, Base Ic 34 In, Overall Height 41 1/4 In, Max. Inlet Temp. 300 Deg. F, Motor Voltage 208-230/460, 3 Phase Operating Amps 6.2/3.1, Motor 2 HP, Wheel Dia 24 1/2 In, Housing Material Spun Aluminum, App General Kitchen, Requires Roof Curb For New Installation, Includes NEMA 1 Junction Box

Grainger Item#	3GY73
Price (ea.)	\$1,482.00
Brand	DAYTON
Mfr. Model#	3GY73
Ship Qty.	1
Sell Qty. (Will-Call)	1
Ship Weight (lbs.)	171.0
Usually Ships*	Today
Catalog Page No.	402'1

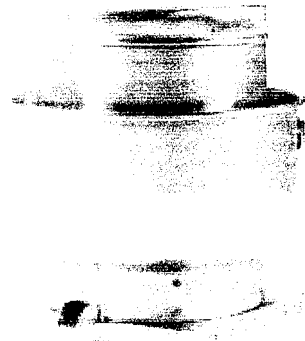

Qty.

Price shown may not reflect your price. [Log in](#) or [register](#)

Tech Specs	Additional Information	Notes & Restrictions	MSDS	Required Accessories	Optional Accessories	Related Products	Repair Parts
Item	Exhaust Ventilator						
Type	Centrifugal Uplast Assembled						
Wheel Dia. (In.)	24 1/2						
Wheel Type	Backward Incline						
CFM @ 0.000-In. SP	8431						
GFM @ 0.125-In. SP	8194						
CFM @ 0.250-In. SP	7985						
CFM @ 0.375-In. SP	7798						
CFM @ 0.500-In. SP	7536						
CFM @ 0.675-In. SP	7233						
CFM @ 0.750-In. SP	6953						
CFM @ 0.875-In. SP	6683						
CFM @ 1.00-In. SP	6375						

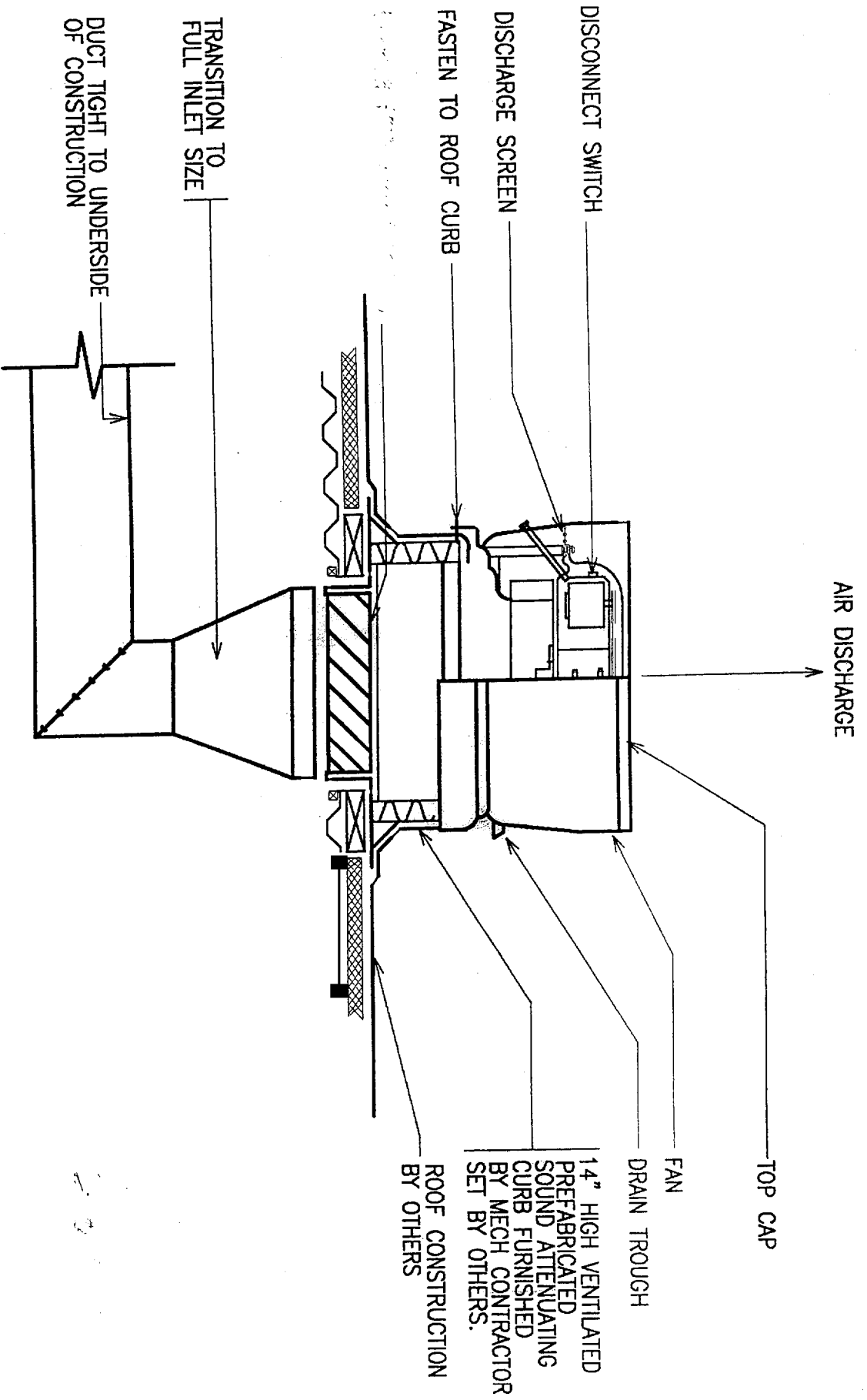

DETAIL OF UPBLAST ROOH EXHAUST FAN
 NOT TO SCALE



PORTLAND MAINE

Strengthening a Remarkable City, Building a Community for Life . www.portlandmaine.gov

Lee Urban- Director of Planning and Development
Michael J. Nugent- Inspections Division Director

Kitchen Exhaust System Checklist and Code Provisions

Dear Applicant,

The following is a checklist to assist you in filing for a permit for a Kitchen Exhaust system. The applicable Mechanical Code provisions have also been attached. Please complete this and submit job specific construction documents that demonstrate compliance with the attached information.

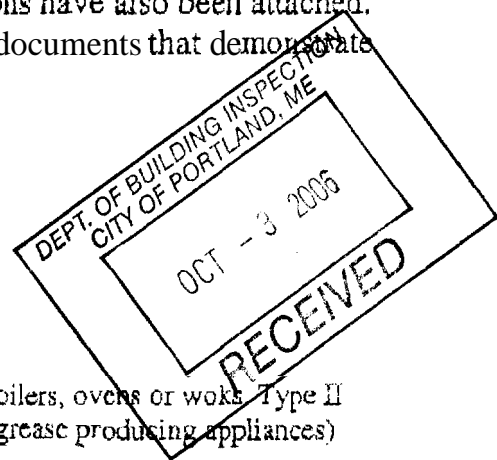

Type of System:

Type I X Type II _____

(Type I systems are systems that vent fryers, grills, broilers, ovens or woks. Type II systems are systems that vent steamers and other non grease producing appliances)

Type of Materials:

Is the hood Stainless steel or other type of steel? Stainless If Other, what Type? _____

Is the duct work Stainless steel or other type of steel? Black Iron If Other, what type? _____

Thickness of the steel for the hood # 3 No 18 MSG

Thickness of the duct for the hood 16 ga

Type of Hood and Duct supports

Head - all thread rod
Duct - all thread rod & angle iron

Type of seams and joints. butt weld

37-5

Grease Gutters provided? at roof top exhaust fan

Hood Clearance from Combustibles materials 3"

Duct Clearance from Combustibles materials 3"

Vibration Isolation System; at fan - flexible duct connector UL listed

Air Velocity within the duct system 1,800 Fpm

Grease accumulation prevention system Filters on hood

Cleanouts at hood, riser & every 12'

Grease Duct enclosure double wall sheetrock shaft

Exhaust Termination on roof

Fire Suppression system Ansul

Exhaust fan mounting and clearance from the roof or wall 46" from

Exhaust fan distance from other vents or openings 18'

Exhaust fan height above adjoining grade 6'

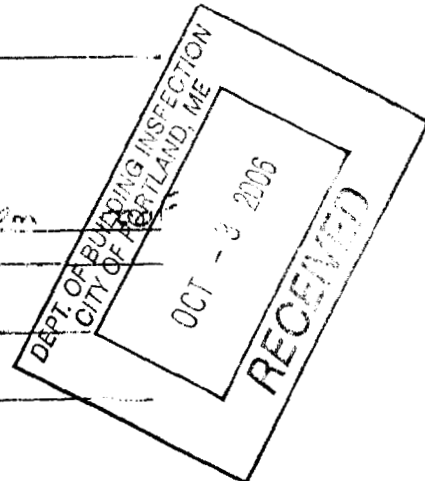

Hood Specs

Style of hood Type I Double Island Canopy

Type of Filter 1" removable mesh at duct location

Height of filter above nearest cooking surface 2'

Capacity of hood in CPM 6300

Make up Air system description and capacity 5700 - wall mounted, lever and motor operated damper wired to open when hood fan is activated and outside air ducted to heating and air conditioning system

3775

SECTION 506 COMMERCIAL KITCHEN HOOD VENTILATION SYSTEM DUCTS AND EXHAUST EQUIPMENT

506.1 General. Commercial kitchen hood ventilation ducts and exhaust equipment shall comply with the requirements of this section. Commercial kitchen grease ducts shall be designed for the type of cooking appliance and hood served.

506.2 Corrosion protection. Ducts exposed to the outside atmosphere or subject to a corrosive environment shall be protected against corrosion in an approved manner.

506.3 Ducts serving Type I hoods. Type I exhaust ducts shall be independent of all other exhaust systems except as provided in Section 506.3.5. Commercial kitchen duct systems serving Type I hoods shall be designed, constructed and installed in accordance with Sections 506.3.1 through 506.3.12.3.

506.3.1 Duct materials. Ducts serving Type I hoods shall be constructed of materials in accordance with Sections 506.3.1.1 and 506.3.1.2.

506.3.1.1 Grease duct materials. Grease ducts serving Type I hoods shall be constructed of steel not less than 0.055 inch (1.4 mm) (No. 16 Gage) in thickness or stainless steel not less than 0.044 inch (1.1 mm) (No. 18 Gage) in thickness.

Exception: Listed and labeled factory-built commercial kitchen grease ducts shall be installed in accordance with Section 304.1,

506.3.1.2 Makeup air ducts. Makeup air ducts connecting to or within 18 inches (457 mm) of a Type I hood shall be constructed and installed in accordance with Sections 603.1, 603.3, 603.4, 603.9, 603.10 and 603.12. Duct insulation installed within 18 inches (457 mm) of a Type I hood shall be noncombustible or shall be listed for the application.

506.3.2 Joints, seams and penetrations of grease ducts. Joints, seams and penetrations of grease ducts shall be made with a continuous liquid-tight weld or braze made on the external surface of the duct system.

Exceptions:

1. Penetrations shall not be required to be welded or brazed where sealed by devices that are listed for the application.
2. Internal welding or brazing shall not be prohibited provided that the joint is formed or ground smooth and is provided with ready access for inspection.
3. Listed and labeled factory-built commercial kitchen grease ducts installed in accordance with Section 304.1.

506.3.2.1 Duct joint types. Duct joints shall be butt joints or overlapping duct joints of either the telescoping or bell type. Overlapping joints shall be installed to prevent ledges and obstructions from collecting grease or interfering with gravity drainage to the intended collection point. The difference between the inside cross-sectional dimensions of overlapping sections of duct shall not exceed 0.25 inch (6 mm). The length of overlap for overlapping duct joints shall not exceed 2 inches (51 mm).

506.3.2.2 Duct-to-hood joints. Duct-to-hood joints shall be made with continuous internal or external liquid-tight welded or brazed joints. Such joints shall be smooth, accessible for inspection, and without grease traps.

Exceptions: This section shall not apply to:

1. A vertical duct-to-hood collar connection made in the top plane of the hood in accordance with all of the following:
 - 1.1. The hood duct opening shall have a 1-inch-deep (25 mm), full perimeter, welded flange turned down into the hood interior at an angle of 90 degrees from the plane of the opening.
 - 1.2. The duct shall have a 1-inch-deep (25 mm) flange made by a 1-inch by 1-inch (25 mm by 25 mm) angle iron welded to the full perimeter of the duct not less than 1 inch (25 mm) above the bottom end of the duct.
 - 1.3. A gasket rated for use at not less than 1,500°F (815°C) is installed between the duct flange and the top of the hood.
 - 1.4. The duct-to-hood joint shall be secured by stud bolts not less than 0.25 inch (6.4 mm) in diameter welded to the hood with a spacing not greater than 4 inches (102 mm) on center for the full perimeter of the opening. All bolts and nuts are to be secured with lock washers.
2. Listed and labeled duct-to-hood collar connections installed in accordance with Section 304.1.

506.3.2.3 Duct-to-exhaust fan connections. Duct-to-exhaust fan connections shall be flanged and gasketed at the base of the fan for vertical discharge fans; shall be flanged, gasketed and bolted to the inlet of the fan for side-inlet utility fans; and shall be flanged, gasketed and bolted to the inlet and outlet of the fan for in-line fans.

506.3.2.4 Vibration isolation. A vibration isolation connector for connecting a duct to a fan shall consist of noncombustible packing in a metal sleeve joint of approved design or shall be a coated-fabric flexible duct connector listed and labeled for the application. Vibration isolation connectors shall be installed only at the connection of a duct to a fan inlet or outlet.

506.3.3 Grease duct supports. Grease duct bracing and supports shall be of noncombustible material securely attached to the structure and designed to carry gravity and seismic loads within the stress limitations of the *International Building Code*. Bolts, screws, rivets and other mechanical fasteners shall not penetrate duct walls.

506.3.4 Air velocity. Grease duct systems serving a Type I hood shall be designed and installed to provide an air velocity within the duct system of not less than 1,500 feet per minute (7.6 m/s).

Exception: The velocity limitations shall not apply within duct transitions utilized to connect ducts to differently

EXHAUST SYSTEMS

sized or shaped openings in hoods and fans, provided that such transitions do not exceed 3 feet (914 mm) in length and are designed to prevent the trapping of grease.

506.3.5 Separation of grease duct system. ~~A separate grease duct system shall be provided for each Type I hood. A~~

separate grease duct system is not required where all of the following conditions are met:

1. All interconnected hoods are located within the same story.
2. All interconnected hoods are located within the same room or in adjoining rooms.
3. Interconnecting ducts do not penetrate assemblies required to be fire-resistance rated.
4. The grease duct system does not serve solid fuel-fired appliances.

506.3.6 Grease duct clearances. Grease duct systems and exhaust equipment serving a Type I hood shall have a clearance to combustible construction of not less than 18 inches (457 mm), and shall have a clearance to noncombustible construction and gypsum wallboard attached to noncombustible structures of not less than 3 inches (76 mm).

Exception: Listed and labeled factory-built commercial kitchen grease ducts and exhaust equipment installed in accordance with Section 304.1.

506.3.7 Prevention of grease accumulation in grease ducts. Duct systems serving a Type I hood shall be constructed and installed so that grease cannot collect in any portion thereof, and the system shall slope not less than one-fourth unit vertical in 12 units horizontal (2-percent slope) toward the hood or toward an approved grease reservoir. Where horizontal ducts exceed 75 feet (22 860 mm) in length, the slope shall not be less than one unit vertical in 12 units horizontal (8.3-percent slope).

506.3.8 Grease duct cleanouts and other openings. Grease duct systems shall not have openings therein other than those required for proper operation and maintenance of the system. Any portion of such system having sections not provided with access from the duct entry or discharge shall be provided with cleanout openings. Cleanout openings shall be equipped with tight-fitting doors constructed of steel having a thickness not less than that required for the duct. Doors shall be equipped with a substantial method of latching, sufficient to hold the door tightly closed. Doors shall be designed so that they are operable without the use of a tool. Door assemblies, including any frames and gasketing, shall be approved for the purpose, and shall not have fasteners that penetrate the duct. Listed and labeled access door assemblies shall be installed in accordance with the terms of the listing.

506.3.8.1 Personnel entry. Where ductwork is large enough to allow entry of personnel, not less than one approved or listed opening having dimensions not less than 20 inches by 20 inches (508 mm by 508 mm) shall be provided in the horizontal sections, and in the top of vertical risers. Where such entry is provided, the duct and its supports shall be capable of supporting the additional load and the cleanouts specified in Section 506.3.8 are not required.

506.3.9 Grease duct horizontal cleanouts. Cleanouts located on horizontal sections of ducts shall be spaced not more than 20 feet (6096 mm) apart. The cleanouts shall be located on the side of the duct with the opening not less than 1.5 inches (38 mm) above the bottom of the duct, and not less than 1 inch (25 mm) below the top of the duct. The opening minimum dimensions shall be 12 inches (305 mm) on each side. Where the dimensions of the side of the duct prohibit the cleanout installation prescribed herein, the openings shall be on the top of the duct or the bottom of the duct. Where located on the top of the duct, the opening edges shall be a minimum of 1 inch (25 mm) from the edges of the duct. Where located in the bottom of the duct, cleanout openings shall be designed to provide internal damming around the opening, shall be provided with gasketing to preclude grease leakage, shall provide for drainage of grease down the duct around the dam, and shall be approved for the application. Where the dimensions of the sides, top or bottom of the duct preclude the installation of the prescribed minimum-size cleanout opening, the cleanout shall be located on the duct face that affords the largest opening dimension and shall be installed with the opening edges at the prescribed distances from the duct edges as previously set forth in this section.

506.3.10 Grease duct enclosure. A grease duct serving a Type I hood that penetrates a ceiling, wall or floor shall be enclosed from the point of penetration to the outlet terminal. A duct shall penetrate exterior walls only at locations where unprotected openings are permitted by the *International Building Code*. Ducts shall be enclosed in accordance with the *International Building Code* requirements for shaft construction. The duct enclosure shall be sealed around the duct at the point of penetration and vented to the outside of the building through the use of weather-protected openings. Clearance from the duct to the interior surface of enclosures of combustible construction shall be not less than 18 inches (457 mm). Clearance from the duct to the interior surface of enclosures of noncombustible construction or gypsum wallboard attached to noncombustible structures shall be not less than 6 inches (152 mm). The duct enclosure shall serve a single grease exhaust duct system and shall not contain any other ducts, piping, wiring or systems.

Exceptions:

1. The shaft enclosure provisions of this section shall not be required where a duct penetration is protected with a through-penetration firestop system classified in accordance with ASTM E 814 and having an "F" and "T" rating equal to the fire-resistance rating of the assembly being penetrated and where the surface of the duct is continuously covered on all sides from the point at which the duct penetrates a ceiling, wall or floor to the outlet terminal with a classified and labeled material, system, method of construction or product specifically evaluated for such purpose, in accordance with a nationally recognized standard for such enclosure materials. Exposed duct wrap systems shall be protected where subject to physical damage.
2. A duct enclosure shall not be required for a grease duct that penetrates only a nonfire-resistance-rated roof/ceiling assembly.

506.3.11 Grease duct fire-resistive access opening. Where cleanout openings are located in ducts within a fire-resistance-rated enclosure, access openings shall be provided in the enclosure at each cleanout point. Access openings shall be equipped with tight-fitting sliding or hinged doors that are equal in fire-resistive protection to that of the shaft or enclosure. An approved sign shall be placed on access opening panels with wording as follows: "ACCESS PANEL. DO NOT OBSTRUCT."

506.3.12 Exhaust outlets serving Type I hoods. Exhaust outlets for grease ducts serving Type I hoods shall conform to the requirements of Sections 506.3.12.1 through 506.3.12.3.

506.3.12.1 Termination above the roof. Exhaust outlets that terminate above the roof shall have the discharge opening located not less than 40 inches (1016 mm) above the roof surface.

506.3.12.2 Termination through an exterior wall. Exhaust outlets shall be permitted to terminate through exterior walls where the smoke, grease, gases, vapors, and odors in the discharge from such terminations do not create a public nuisance or a fire hazard. Such terminations shall not be located where protected openings are required by the International Building Code. Other exterior openings shall not be located within 3 feet (914 mm) of such terminations.

506.3.12.3 Termination location. Exhaust outlets shall be located not less than 10 feet (3048 mm) horizontally from parts of the same or contiguous buildings, adjacent property lines and air intake openings into any building and shall be located not less than 10 feet (3048 mm) above the adjoining grade level.

Exception: Exhaust outlets shall terminate not less than 5 feet (1524 mm) from an adjacent building, adjacent property line and air intake openings into a building where air from the exhaust outlet discharges away from such locations.

506.4 Ducts serving Type II hoods. Single or combined Type II exhaust systems for food-processing operations shall be independent of all other exhaust systems. Commercial kitchen exhaust systems serving Type II hoods shall comply with Sections 506.4.1 and 506.4.2.

506.4.1 Type II exhaust outlets. Exhaust outlets for ducts serving Type II hoods shall comply with Sections 401.5 and 401.5.2. Such outlets shall be protected against local weather conditions and shall meet the provisions for exterior wall opening protectives in accordance with the International Building Code.

506.4.2 Ducts. Ducts and plenums serving Type II hoods shall be constructed of rigid metallic materials. Duct construction, installation, bracing and supports shall comply with Chapter 6. Ducts subject to positive pressure and ducts conveying moisture-laden or waste-heat-laden air shall be constructed, joined and sealed in an approved manner.

506.5 Exhaust equipment. Exhaust equipment, including fans and grease reservoirs, shall comply with Section 506.5.1

through 506.5.5 and shall be of an approved design or shall be listed for the application.

506.5.1 Exhaust fans. Exhaust fan housings serving a Type I hood shall be constructed as required for grease ducts in 506.5.1.1.

Exception: Fans listed and labeled in accordance with UL 762.

506.5.1.1 Fan motor. Exhaust fan motors shall be located outside of the exhaust airstream.

506.5.2 Exhaust fan discharge. Exhaust fans shall be positioned so that the discharge will not impinge on the roof, other equipment or appliances or parts of the structure. A vertical discharge fan shall be manufactured with an approved drain outlet at the lowest point of the housing to permit drainage of grease to an approved grease reservoir.

506.5.3 Exhaust fan mounting. An upblast fan shall be hinged and supplied with a flexible weatherproof electrical cable to permit inspection and cleaning. The ductwork shall extend a minimum of 18 inches (457 mm) above the roof surface.

506.5.4 Clearances. Exhaust equipment serving a Type I hood shall have a clearance to combustible construction of not less than 18 inches (457 mm).

Exception: Factory-built exhaust equipment installed in accordance with Section 304.1 and listed for a lesser clearance.

506.5.5 Termination location. The outlet of exhaust equipment serving Type I hoods, shall be in accordance with Section 506.3.12.3

Exception: The minimum horizontal distance between vertical discharge fans and parapet-type building structures shall be 2 feet (610 mm) provided that such structures are not higher than the top of the fan discharge opening.

SECTION 507 COMMERCIAL KITCHEN HOODS

507.1 General. Commercial kitchen exhaust hoods shall comply with the requirements of this section. Hoods shall be Type I or Type II and shall be designed to capture and confine cooking vapors and residues.

Exceptions:

1. Factory-built commercial exhaust hoods which are tested in accordance with UL 710, listed, labeled and installed in accordance with Section 304.1 shall not be required to comply with Sections 507.4, 507.7, 507.11, 507.12, 507.13, 507.14 and 507.15.
2. Factory-built commercial cooking recirculating systems which are tested in accordance with UL 197, listed, labeled and installed in accordance with Section 304.1 shall not be required to comply with Sections 507.4, 507.5, 507.7, 507.12, 507.13, 507.14 and 507.15.
3. Net exhaust volumes for hoods shall be permitted to be reduced during no-load cooking conditions, where

EXHAUST SYSTEMS

engineered or listed multi-speed or variable-speed controls automatically operate the exhaust system to maintain capture and removal of cooking effluents as required by this section.

507.2 Where required. A Type I or Type II hood shall be installed at or above all commercial cooking appliances in accordance with Sections 507.2.1 and 507.2.2. Where any cooking appliance under a single hood requires a Type I hood, a Type I hood shall be installed. Where a Type II hood is required, a Type I or Type II hood shall be installed.

507.2.1 Type I hoods. Type I hoods shall be installed where cooking appliances produce grease or smoke, such as occurs with griddles, fryers, broilers, ovens, ranges and wok ranges.

507.2.2 Type II hoods. Type II hoods shall be installed where cooking or dishwashing appliances produce heat or steam and do not produce grease or smoke, such as steamers, kettles, pasta cookers and dishwashing machines.

Exceptions:

1. Under-counter-type commercial dishwashing machines,
2. A Type II hood is not required for dishwashers and potwashers that are provided with heat and water vapor exhaust systems that are supplied by the appliance manufacturer and are installed in accordance with the manufacturer's instructions.

507.2.3 Domestic cooking appliances used for commercial purposes. Domestic cooking appliances utilized for commercial purposes shall be provided with Type I or Type II hoods as required for the type of appliances and processes in accordance with Sections 507.2, 507.2.1 and 507.2.2.

507.2.4 Solid fuel. Type I hoods for use over solid fuel-burning cooking appliances shall discharge to an exhaust system that is independent of other exhaust systems.

507.3 Fuel-burning appliances. Where vented fuel-burning appliances are located in the same room or space as the hood, provisions shall be made to prevent the hood system from interfering with normal operation of the appliance vents.

507.4 Type I materials. Type I hoods shall be constructed of steel not less than 0.043 inch (1.09 mm) (No. 18 MSG) in thickness, or stainless steel not less than 0.037 inch (0.94 mm) (No. 20 MSG) in thickness.

507.5 Type II hood materials. Type II hoods shall be constructed of steel not less than 0.030 inch (0.76 mm) (No. 22 Gage) in thickness, stainless steel not less than 0.024 inch (0.61 mm) (No. 24 Gage) in thickness, copper sheets weighing not less than 24 ounces per square foot (7.3 kg/m²), or of other approved material and gage.

507.6 Supports. Type I hoods shall be secured in place by non-combustible supports. All Type I and Type II hood supports shall be adequate for the applied load of the hood, the unsupported ductwork, the effluent loading, and the possible weight of personnel working in or on the hood.

507.7 Hood joints, seams and penetrations. Hood joints, seams and penetrations shall comply with Sections 507.7.1 and 507.7.2.

507.7.1 Type I hoods. External hood joints, seams and penetrations for Type I hoods shall be made with a continuous external liquid-tight weld or braze to the lowest outermost perimeter of the hood. Internal hood joints, seams, penetrations, filter support frames, and other appendages attached inside the hood shall not be required to be welded or brazed but shall be otherwise sealed to be grease tight.

Exceptions:

1. Penetrations shall not be required to be welded or brazed where sealed by devices that are listed for the application.
2. Internal welding or brazing of seams, joints, and penetrations of the hood shall not be prohibited provided that the joint is formed smooth or ground so as to not trap grease, and is readily cleanable.

507.7.2 Type II hoods. Joints, seams and penetrations for Type II hoods shall be constructed as set forth in Chapter 6, shall be sealed on the interior of the hood and shall provide a smooth surface that is readily cleanable and water tight.

507.8 Cleaning and grease gutters. A hood shall be designed to provide for thorough cleaning of the entire hood. Grease gutters shall drain to an approved collection receptacle that is fabricated, designed and installed to allow access for cleaning.

507.9 Clearances for Type I hood. A Type I hood shall be installed with a clearance to combustibles of not less than 18 inches (457 mm).

Exception: Clearance shall not be required from gypsum wallboard attached to noncombustible structures provided that a smooth, cleanable, nonabsorbent and noncombustible material is installed between the hood and the gypsum wallboard over an area extending not less than 18 inches (457 mm) in all directions from the hood.

507.10 Hoods penetrating a ceiling. Type I hoods or portions thereof penetrating a ceiling, wall or furred space shall comply with all the requirements of Section 506.3.10.

507.11 Grease filters. Type I hoods shall be equipped with listed grease filters designed for the specific purpose. Grease-collecting equipment shall be provided with access for cleaning. The lowest edge of a grease filter located above the cooking surface shall be not less than the height specified in Table 507.11.

**TABLE 507.11
MINIMUM DISTANCE BETWEEN THE LOWEST EDGE OF A
GREASE FILTER AND THE COOKING SURFACE OR THE
HEATING SURFACE**

TYPE OF COOKING APPLIANCES	HEIGHT ABOVE COOKING SURFACE (feet)
Without exposed flame	0.5
Exposed flame and burners	2
Exposed charcoal and charbroil type	3.5

installed in frames or holders so as to be readily removable without the use of separate tools, unless designed and installed to be cleaned in place and the system is equipped for such cleaning in place. Removable filter units shall be of a size that will allow them to be cleaned in a dishwashing machine or pot sink. Filter units shall be arranged in place or provided with drip-intercepting devices to prevent grease or other condensate from dripping into food or on food preparation surfaces.

507.11.2 Mounting position. Filters shall be installed at an angle of not less than 45 degrees (0.79 rad) from the horizontal and shall be equipped with a drip tray beneath the lower edge of the filters.

507.12 Canopy size and location. The inside lower edge of canopy-type commercial cooking hoods shall overhang or extend a horizontal distance of not less than 6 inches (152 mm) beyond the edge of the cooking surface, on all open sides. The vertical distance between the front lower lip of the hood and the cooling surface shall not exceed 4 feet (1219 mm).

Exception: The hood shall be permitted to be flush with the outer edge of the cooking surface where the hood is closed to the appliance side by a noncombustible wall or panel.

507.13 Capacity of hoods. Commercial food service hoods shall exhaust a minimum net quantity of air determined in accordance with this section and Sections 507.13.1 through 507.13.4. The net quantity of exhaust air shall be calculated by subtracting any airflow supplied directly to a hood cavity from the total exhaust flow rate of a hood. Where any combination of extra-heavy-duty, heavy-duty, medium-duty, and light-duty cooking appliances are utilized under a single hood, the highest exhaust rate required by this section shall be used for the entire hood.

507.13.1 Extra-heavy-duty cooking appliances. The minimum net airflow for Type I hoods used for extra-heavy-duty cooking appliances shall be determined as follows:

Type of Hood	CFM per linear foot of hood
Wall-mounted canopy	550
Single island canopy	700
Double island canopy (per side)	550
Backshelf/pass-over	Not allowed
Eyebrow	Not allowed

For SI: 1 cfm per linear foot = 1.55 L/s per linear meter.

507.13.2 Heavy-duty cooking appliances. The minimum net airflow for Type I hoods used for heavy-duty cooking appliances shall be determined as follows:

Type of Hood	CFM per linear foot of hood
Wall-mounted canopy	400
Single island canopy	600
Double island canopy (per side)	400
Backshelf/pass-over	400
Eyebrow	Not allowed

For SI: 1 cfm per linear foot = 1.55 L/s per linear meter

507.13.3 Medium-duty cooking appliances. The minimum net airflow for Type I hoods used for medium-duty cooking appliances shall be determined as follows:

Type of Hood	CFM per linear foot of hood
Wall-mounted canopy	300
Single island canopy	500
Double island canopy (per side)	300
Backshelf/pass-over	300
Eyebrow	250

For SI: 1 cfm per linear foot = 1.55 L/s per linear meter.

507.13.4 Light-duty cooking appliances. The minimum net airflow for Type I hoods used for light duty cooking appliances and food service preparation and cooking operations approved for use under a Type II hood shall be determined as follows:

Type of Hood	CFM per linear foot of hood
Wall-mounted canopy	200
Single island canopy	400
Double island canopy (per side)	250
Backshelf/pass-over	250
Eyebrow	250

For SI: 1 cfm per linear foot = 1.55 L/s per linear meter.

507.14 Noncanopy size and location. Noncanopy-type hoods shall be located a maximum of 3 feet (914 mm) above the cooking surface. The edge of the hood shall be set back a maximum of 1 foot (305 mm) from the edge of the cooking surface.

507.15 Exhaust outlets. Exhaust outlets located within the hood shall be located so as to optimize the capture of particulate matter. Each outlet shall serve not more than a 12-foot (3658 mm) section of hood.

507.16 Performance test. A performance test shall be conducted upon completion and before final approval of the installation of a ventilation system serving commercial cooking appliances. The test shall verify the rate of exhaust airflow required by Section 507.13, makeup airflow required by Section 508, and proper operation as specified in this chapter. The permit holder shall furnish the necessary test equipment and devices required to perform the tests.

507.16.1 Capture and containment test. The permit holder shall verify capture and containment performance of the exhaust system. This field test shall be conducted with all appliances under the hood at operating temperatures. Capture and containment shall be verified visually by observing smoke or steam produced by actual or simulated cooking, such as with smoke candles, smoke puffers, etc.

SECTION 508

COMMERCIAL KITCHEN MAKEUP AIR

508.1 Makeup air. Makeup air shall be supplied during the operation of commercial kitchen exhaust systems that are provided for commercial cooking appliances. The amount of

EXHAUST SYSTEMS

makeup air supplied shall be approximately equal to the amount of exhaust air. The makeup air shall not reduce the effectiveness of the exhaust system. Makeup air shall be provided by gravity or mechanical means or both. For mechanical makeup air systems, the exhaust and makeup air systems shall be electrically interlocked to insure that makeup air is provided whenever the exhaust system is in operation. Makeup air intake opening locations shall comply with Sections 401.5 and 401.5.1.

508.1.1 Makeup air temperature. The temperature differential between makeup air and the air in the conditioned space shall not exceed 10°F (6°C).

Exceptions:

1. Makeup air that is part of the air-conditioning system.
2. Makeup air that does not decrease the comfort conditions of the occupied space.

508.2 Compensating hoods. Manufacturers of compensating hoods shall provide a label indicating minimum exhaust flow and/or maximum makeup airflow that provides capture and containment of the exhaust effluent.

SECTION 509 FIRE SUPPRESSION SYSTEMS

509.1 Where required. Commercial cooking appliances required by Section 507.2.1 to have a Type I hood shall be provided with an approved automatic fire suppression system complying with the *International Building Code* and the *International Fire Code*.

SECTION 510 HAZARDOUS EXHAUST SYSTEMS

510.1 General. This section shall govern the design and construction of duct systems for hazardous exhaust and shall determine where such systems are required. Hazardous exhaust systems are systems designed to capture and control hazardous emissions generated from product handling or processes, and convey those emissions to the outdoors. Hazardous emissions include flammable vapors, gases, fumes, mists or dusts, and volatile or airborne materials posing a health hazard, such as toxic or corrosive materials. For the purposes of this section, the health-hazard rating of materials shall be as specified in *NFPA 704*.

510.2 Where required. A hazardous exhaust system shall be required wherever operations involving the handling or processing of hazardous materials, in the absence of such exhaust systems and under normal operating conditions, have the potential to create one of the following conditions:

1. A flammable vapor, gas, fume, mist or dust is present in concentrations exceeding 25 percent of the lower flammability limit of the substance for the expected room temperature.
2. A vapor, gas, fume, mist or dust with a health-hazard rating of 4 is present in any concentration.

3. A vapor, gas, fume, mist or dust with a health-hazard rating of 1, 2 or 3 is present in concentrations exceeding 1 percent of the median lethal concentration of the substance for acute inhalation toxicity.

[F] 510.2.1 Lumber yards and woodworking facilities

Equipment or machinery located inside buildings at lumber yards and woodworking facilities which generates or emits combustible dust shall be provided with an approved dust-collection and exhaust system installed in conformance with this section and the *International Fire Code*. Equipment and systems that are used to collect, process or convey combustible dusts shall be provided with an approved explosion-control system.

[F] **510.2.2** Combustible fibers. Equipment or machinery within a building which generates or emits combustible fibers shall be provided with an approved dust-collecting and exhaust system. Such systems shall comply with this code and the *International Fire Code*.

510.3 Design and operation. The design and operation of the exhaust system shall be such that flammable contaminants are diluted in noncontaminated air to maintain concentrations in the exhaust flow below 25 percent of the contaminant's lower flammability limit.

510.4 Independent system. Hazardous exhaust systems shall be independent of other types of exhaust systems. Incompatible materials, as defined in the *International Fire Code*, shall not be exhausted through the same hazardous exhaust system. Hazardous exhaust systems shall not share common shafts with other duct systems, except where such systems are hazardous exhaust systems originating in the same fire area.

Contaminated air shall not be recirculated to occupied areas unless the contaminants have been removed. Air contaminated with explosive or flammable vapors, fumes or dusts; flammable or toxic gases; or radioactive material shall not be recirculated.

510.5 Design. Systems for removal of vapors, gases and smoke shall be designed by the constant velocity or equal friction methods. Systems conveying particulate matter shall be designed employing the constant velocity method.

510.5.1 Balancing. Systems conveying explosive or radioactive materials shall be prebalanced by duct sizing. Other systems shall be balanced by duct sizing with balancing devices, such as dampers. Dampers provided to balance air-flow shall be provided with securely fixed minimum-position blocking devices to prevent restricting flow below the required volume or velocity.

510.5.2 Emission control. The design of the system shall be such that the emissions are confined to the area in which they are generated by air currents, hoods or enclosures and shall be exhausted by a duct system to a safe location or treated by removing contaminants.

510.5.3 Hoods required. Hoods or enclosures shall be used where contaminants originate in a limited area of a space. The design of the hood or enclosure shall be such that air currents created by the exhaust systems will capture the contaminants and transport them directly to the exhaust duct.