

**GENTEX  
CORPORATION**

SIGNALING



A Smarter Vision®

# **GN-503 SERIES COMBINATION PHOTOELECTRIC SMOKE & CARBON MONOXIDE (CO) ALARM**

**PHOTOELECTRIC TYPE  
SINGLE/MULTIPLE STATION  
SMOKE ALARM AND  
ELECTROCHEMICAL CARBON  
MONOXIDE ALARM,  
AC POWERED, WITH 9VDC  
BATTERY BACK-UP**

**NOTE: GENTEX LEGACY PRODUCTS INCLUDE 9120, 9123  
7100, 7103, 710CS, 713CS, 7109CS, 7139CS, GN-200, GN-203,  
GN-300 AND GN-303 SERIES. THESE PRODUCTS WILL NOT  
ACTIVATE FOR A CO EVENT WHEN TANDEM  
INTERCONNECTED TO A GENTEX CO OR SMOKE/CO ALARM.**

#### LIMITED WARRANTY

For a period of 12 months from the date of purchase, or a maximum of 18 months from the date of manufacture, Gentex warrants to you, the original consumer purchaser, that your smoke/CO Alarm will be free from defects in workmanship, materials, and construction under normal use and service. The CO sensor has a limited warranty period of 5 years from date of installation. If a defect in workmanship, materials, or construction should cause your smoke/CO Alarm to become inoperable within the warranty period, Gentex will repair your smoke/CO Alarm or furnish you with a new or rebuilt replacement smoke/CO Alarm without charge to you except for postage required to return the smoke/CO Alarm to us. Your repaired or replacement smoke/CO Alarm will be returned to you free of charge and it will be covered under this warranty for the balance of the warranty period.

This warranty is void if our inspection of your smoke/CO Alarm shows that the damage or failure was caused by abuse, misuse, abnormal usage, faulty installation, improper maintenance, or repairs other than those performed by us.

ANY WARRANTIES IMPLIED UNDER ANY STATE LAW, INCLUDING IMPLIED WARRANTIES OF MERCHANTABILITY OR FITNESS FOR A PARTICULAR PURPOSE, APPLY ONLY FOR THE WARRANTY PERIOD SPECIFIED ABOVE. PLEASE NOTE THAT SOME STATES DO NOT ALLOW LIMITATIONS ON HOW LONG AN IMPLIED WARRANTY

LASTS, SO THE ABOVE EXCLUSION MAY NOT APPLY TO YOU.

GENTEX WILL NOT BE LIABLE FOR ANY LOSS, DAMAGE, INCIDENTAL OR CONSEQUENTIAL DAMAGES OF ANY KIND ARISING IN CONNECTION WITH THE SALE, USE, OR REPAIR OF THIS SMOKE/CO ALARM. PLEASE NOTE THAT SOME STATES DO NOT ALLOW THE EXCLUSION OR LIMITATION OF INCIDENTAL OR CONSEQUENTIAL DAMAGES. SO THE ABOVE EXCLUSION MAY NOT APPLY TO YOU.

If a defect in workmanship, materials, or construction should cause your Smoke/CO Alarm to become inoperable within the warranty period, you must return the smoke/CO Alarm to Gentex postage prepaid. You must also pack the smoke/CO Alarm to minimize the risk of it being damaged in transit. You must also enclose a return address. smoke/CO Alarms returned for warranty service should be sent to: Gentex Corporation, 10985 Chicago Drive, Zeeland, MI 49464.

If we receive a smoke/CO Alarm in a damaged condition as the result of shipping, we will notify you and you must file a claim with the Shipper.

THIS LIMITED WARRANTY GIVES YOU SPECIFIC LEGAL RIGHTS. YOU MAY ALSO HAVE OTHER RIGHTS WHICH VARY FROM STATE TO STATE.

#### Important Notice:

These materials have been prepared by Gentex Corporation ("Gentex") for informational purposes only, are necessarily summary, and are not purported to serve as legal advice and should not be used as such. Gentex makes no representations and warranties, express or implied, that these materials are complete and accurate, up-to-date, or in compliance with all relevant local, state and federal laws, regulations and rules. The materials do not address all legal considerations as there is inevitable uncertainty regarding interpretation of laws, regulations and rules and the application of such laws, regulations and rules to particular fact patterns. Each person's activities can differently affect the obligations that exist under applicable laws, regulations or rules. Therefore, these materials should be used only for informational purposes and should not be used as a substitute for seeking professional legal advice. Gentex will not be responsible for any action or failure to act in reliance upon the information contained in this material.

**GENTEX CORPORATION  
10985 CHICAGO DRIVE,  
ZEELAND, MI 49464  
PHONE: 1-800-436-8391  
www.gentex.com**

550-0563-AAA

05/01/2012

# GENTEX CORPORATION GN-503 SERIES COMBINATION PHOTOELECTRIC

A Smarter Vision®



## SMOKE & CARBON MONOXIDE (CO) ALARM PHOTOELECTRIC TYPE SINGLE/MULTIPLE STATION SMOKE ALARM AND ELECTROCHEMICAL CARBON MONOXIDE ALARM, AC POWERED, WITH 9VDC BATTERY BACK-UP

### Installation Instructions - Owner's/User's Information Manual -READ CAREFULLY AND SAVE

#### INTRODUCTION GN-503 SERIES

The GN-503 Series combination photoelectric smoke alarm and electrochemical carbon monoxide (CO) alarm is listed for use as an evacuation device in all dwelling units. The device has a solid state piezo signal to warn and alert the household to the presence of threatening smoke and carbon monoxide.

Your combination smoke/CO alarm is designed to detect the smoke that results from an actual fire or carbon monoxide gas. Consequently, it is uncommon for household smoke such as cigarette smoke or normal cooking smoke to cause an alarm.

#### BASIC SAFETY INFORMATION

Dangers, Warnings, Cautions and Notices alert you to important operating procedures or to potentially hazardous situations. Pay special attention to these items.

#### WARNING

- This combination photoelectric smoke/CO alarm is listed for use in single-family and multi-family residences, along with hotels, motels and other commercial residential occupancies.
- This CO alarm will only indicate the presence of increased levels of carbon monoxide gas at the sensor. Increased levels of carbon monoxide gas may be present in other areas.
- This combination smoke/CO alarm must receive continuous 120VAC, 60Hz, pure sine wave electrical power (battery is meant for emergency back-up only). In order for the emergency battery back-up to work, a new battery must be properly installed (see BATTERY INSTALLATION section).
- NEVER ignore your combination smoke/CO alarm if it sounds. Refer to IF YOUR SMOKE/CO ALARM SOUNDS section for more information. Failure to do so can result in serious injury or death.
- Test this device once a week. If the device ever fails to test correctly, replace immediately! If the device is not working properly, it can not alert you to a problem.
- This product is intended for use in indoor locations of family dwelling units. It is not designed to measure CO levels in compliance with Occupational Safety and Health Administration (OSHA) commercial or industrial standards. Individuals with medical conditions that may make them more sensitive to carbon monoxide may consider using warning devices which provide audible and visual signals for carbon monoxide concentrations under 30 ppm. For additional information on carbon monoxide and your medical condition, contact your physician.

#### MODELS

\*GN-503.....120VAC, 60Hz with temporal horn

\* These units produce a temporal 3 audible alarm for smoke alarm notification. Per NFPA 72, the American National Standard Audible Emergency Evacuation Signal as defined in ANSI S3.41, is required whenever the intended response is to evacuate the building. These units also produce a temporal 4 audible alarm for carbon monoxide alarm notification, per NFPA 720.

#### OPTIONS

F - 1 Form A/1 Form C Auxiliary Relay

FF - 2 Form A/2 Form C Auxiliary Relays

#### ELECTRICAL SPECIFICATIONS

OPERATING VOLTAGE.....120VAC, 60Hz

OPERATING CURRENT..... 0.045 amps

OPERATING AMBIENT TEMPERATURE RANGE.....40°F to 100°F

ALARM HORN RATING..... meets or exceeds 85dBA at 10 feet

NOTICE: IN THE EVENT AC POWER FAILS, A 9VDC BATTERY WILL PROVIDE PROPER ALARM OPERATION FOR A MINIMUM OF 24 HOURS.

#### HOW THE SMOKE/CO ALARM WORKS

##### GENERAL INFORMATION - SMOKE ALARM

The GN-503 Series alarm operates on the photoelectric light scatter principle for the smoke sensor and electrochemical sensing principal for the CO sensor. The device's sensing chamber houses a light source and a light sensor.

For smoke detection, the darkened sensing chamber is exposed to the atmosphere and designed to permit optimum smoke entry from any direction while rejecting light from outside the smoke/CO alarm.

The light source is an infrared (invisible) LED which pulses every 30 seconds to detect smoke. The light sensor is a photodiode matched to the light frequency of the LED light source.

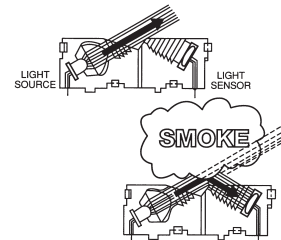

Under normal conditions, the light generated by the pulsing infrared LED is not seen by the light sensor, as it is positioned out of the direct path of the light beam. When smoke enters the sensing chamber, light from the pulsing LED light source is reflected by the smoke particles onto the photodiode light sensor. At the first sighting of smoke, the device is put into a pre-alarm mode. This is indicated by a rapidly flashing red LED on the face of the smoke/CO alarm.

Once the light sensor confirms smoke for 2 consecutive pulses inside the chamber, the light sensor produces the signal necessary to trigger the device and sound the electronic horn. This smoke alarm features a permanently installed sensor, an indicator light and an 85dBA, temporal 3 alarm horn. The device will continue to alarm until the smoke is no longer sensed in the chamber.

*Smoke Alarm Temporal 3 Activation Signal:* NFPA 72, 2010 Edition A.29.3.5: The standard fire alarm evacuation signal is a three-pulse temporal pattern using any appropriate sound. The pattern consists of the following in this order:

- (1) An "on" phase lasting 0.5 second  $\pm$  10 percent.
- (2) An "off" phase lasting 0.5 second  $\pm$  10 percent for three successive "on" periods.
- (3) An "off" phase lasting 1.5 seconds  $\pm$  10 percent.

##### GENERAL INFORMATION - CARBON MONOXIDE ALARM

NOTICE: CO PROBLEMS CAN OCCUR AT ANY TIME.

When fully powered, the device samples the air and takes a new reading about every 30 seconds. A microchip inside the unit stores each reading and remembers the levels of CO it has been exposed to over time. The CO portion of the smoke/CO alarm will sound when it has been exposed to a critical level of CO (measured in parts per million or ppm) within a specified time (measured in minutes). This CO alarm features a permanently installed sensor, an indicator light and an 85dBA, temporal 4 alarm horn. It also has a reset feature to temporarily quiet the alarm horn. If critical levels of CO remain, the alarm will re-activate and sound.

*Carbon Monoxide Alarm Temporal 4 Activation Signal:* NFPA 720, 2012 Edition: 5.8.6.5.1: The audible carbon monoxide alarm signal shall comply with the following:

- (1) Signals shall be a single tone pattern consisting of four cycles of 100 milliseconds  $\pm$  10 percent "on" and 100 milliseconds of  $\pm$  10 percent "off," followed by 5 seconds  $\pm$  10 percent "off."
- (2) After the initial 4 minutes of alarm, the 5-second "off" time shall be permitted to be changed to 60 seconds  $\pm$  10 percent.
- (3) The alarm signal shall be repeated in compliance with 5.8.6.5.1 (1) and 5.8.6.5.1 (2) until the alarm resets or the alarm signal is manually silenced.

**NOTICE:** MALFUNCTION WARNING: THIS UNIT PERFORMS A SELF-DIAGNOSTIC TEST. IF THE ALARM MALFUNCTIONS IT SHOULD BE REPLACED IMMEDIATELY. See CHECKOUT & TROUBLESHOOTING for more information.

## HOW TO TELL IF THE SMOKE/CO ALARM IS WORKING PROPERLY

- ♦ Your device is provided with an alarm horn and flashing red Light Emitting Diode (LED) indicator, which flashes every 15-30 seconds, and a green AC power on LED and red flashing LED for CO event.
- ♦ Test button function: when test button is pressed, the full operation of the light source, light sensor and CO sensor circuit are verified and will initiate an alarm. See CHECKOUT AND TROUBLESHOOTING for additional information.
- ♦ If the battery is low or missing, a chirp will be emitted. If the smoke/CO alarm is malfunctioning, two chirps will sound. If AC power fails, the green LED will turn off. Reference Troubleshooting Guide on page 5-8.

### NOTE: TANDEM INTERCONNECTED DEVICES

- ♦ When testing one device, the device that is activated will flash the red indicator light and sound its alarm horn. All other units will sound the alarm horn with their red indicator lights remaining off.

## FIRE PROTECTION PLAN: WHAT YOU CAN DO TO MAKE YOUR FAMILY SAFE FROM FIRES

This smoke/CO alarm can quickly alert you to the presence of smoke; but cannot prevent fire. The ultimate responsibility for fire protection rests solely on you.

Installing smoke/CO alarms is just the first step in protecting your family from fires. You also must reduce the chances that fires will start in your home and increase your chances of safely escaping if one does start. To have an effective fire safety program:

- Install smoke/CO alarms properly following the instructions in this manual. Keep your units clean. Test your devices weekly and have unit repaired or replace unit it when it no longer functions.** As with any electronic product, smoke/CO alarms have a limited life, it is recommended that smoke/CO alarms be replaced when end of life signal sounds. Smoke/CO alarms that don't work cannot protect you.
- Follow safety rules and prevent hazardous situations:**
  - ♦ Use smoking materials properly; never smoke in bed.
  - ♦ Keep matches and cigarette lighters away from children.
  - ♦ Store flammable materials in proper containers and never use them near open flames or sparks.
  - ♦ Keep electrical appliances and cords in good working order and do not overload electrical circuits.
  - ♦ Keep stoves, fireplaces, chimneys, and barbecue grills grease-free and make sure they are properly installed away from combustible materials.
  - ♦ Keep portable heaters and open flames such as candles away from combustible materials.
  - ♦ Do not allow rubbish to accumulate.
  - ♦ Do not leave small children home alone.
- Develop a family escape plan and practice it with your entire family, especially small children.**
  - ♦ Draw and post a floor plan of your home and find two ways to exit from each room. There should be one way to get out of each bedroom without opening the door.
  - ♦ Teach children what the smoke/CO alarm signal means, and that they must be prepared to leave the residence by themselves if necessary. Show them how to check to see if doors are hot before opening them, how to stay close to the floor and crawl if necessary, and how to use the alternate exit if the door is hot and should not be opened.
  - ♦ Decide on a meeting place a safe distance from your house and make sure that all your children understand that they should go and wait for you if there is a fire.
  - ♦ Hold fire drills at least every 6 months to make sure that everyone, even small children, know what to do to escape safely.
  - ♦ Know where to go to call the fire department from outside your residence.
  - ♦ Provide emergency equipment such as fire extinguishers and teach your family to use this equipment properly.
- Bedroom doors should be closed while sleeping if a smoke/CO alarm is installed in the bedroom.** They act as a barrier against heat and smoke.

## WHAT TO DO IF THERE IS A FIRE IN YOUR HOME

If you have prepared family escape plans and practiced them with your family, you have increased their chances of escaping safely. Review the following rules with your children when you have fire drills so everyone will remember them in a real fire emergency. If alarm should sound:

- a. Don't panic; stay calm. Your safe escape may depend on thinking clearly and remembering what you have practiced.
- b. Get out of the house following a planned escape route as quickly as possible. Do not stop to collect anything or to get dressed.

- c. Open doors carefully only after feeling to see if they are hot. Do not open a door if it is hot; use an alternate escape route.
- d. Stay close to the floor; smoke and hot gases rise.
- e. Cover your nose and mouth with a cloth, wet if possible, and take short, shallow breaths.
- f. Keep doors and windows closed unless you open them to escape.
- g. Meet at your prearranged meeting place after leaving the house.
- h. Call the Fire Department as soon as possible from outside your house. Give the address and your name.
- i. Never re-enter a burning building.

Contact your local Fire Department for more information on making your home safer from fires and about preparing your family's escape plans.

**NOTICE:** CURRENT STUDIES HAVE SHOWN SMOKE/CO ALARMS MAY NOT AWAKEN ALL SLEEPING INDIVIDUALS, AND THAT IT IS THE RESPONSIBILITY OF INDIVIDUALS IN THE HOUSEHOLD THAT ARE CAPABLE OF ASSISTING OTHERS TO PROVIDE ASSISTANCE TO THOSE WHO MAY NOT BE AWAKENED BY THE ALARM SOUND, OR TO THOSE WHO MAY BE INCAPABLE OF SAFELY EVACUATING THE AREA UNASSISTED.

## WHAT THIS SMOKE/CO ALARM CAN DO: SMOKE DETECTION

This smoke/CO alarm is designed to sense smoke entering its sensing chamber. It does not sense heat or flames.

When properly located, installed, and maintained, this smoke/CO alarm is designed to provide early warning of developing fires at a reasonable cost. This device monitors the air and, when it senses smoke, activates its built-in alarm horn. It can provide precious time for you and your family to escape from your residence before a fire spreads. Such an early warning, however, is possible only if the smoke/CO alarm is located, installed, and maintained as specified in this User's Manual.

**NOTICE:** THIS SMOKE/CO ALARM IS DESIGNED FOR USE WITHIN SINGLE RESIDENTIAL LIVING UNITS ONLY; THAT IS, IT SHOULD BE USED INSIDE A SINGLE-FAMILY HOME OR ONE APARTMENT OF A MULTI-FAMILY BUILDING. IN A MULTI-FAMILY BUILDING, THE DEVICE MAY NOT PROVIDE EARLY WARNING FOR RESIDENTS IF IT IS PLACED OUTSIDE OF THE RESIDENTIAL UNITS, SUCH AS ON OUTSIDE PORCHES, IN CORRIDORS, LOBBIES, BASEMENTS, OR IN OTHER APARTMENTS. IN MULTI-FAMILY BUILDINGS, EACH RESIDENTIAL UNIT SHOULD HAVE SMOKE/CO ALARMS TO ALERT THE RESIDENTS OF THAT UNIT. DEVICES DESIGNED TO BE INTERCONNECTED SHOULD BE INTERCONNECTED WITHIN ONE FAMILY RESIDENCE ONLY; OTHERWISE, NUISANCE ALARMS WILL OCCUR WHEN A SMOKE/CO ALARM IN ANOTHER LIVING UNIT IS TESTED.

## NOTICE: WHAT SMOKE/CO ALARMS CANNOT DO: SMOKE DETECTION

**Smoke/CO alarms will not work without power.** A battery must be connected to the device to maintain proper operation if AC power supply is cut off by an electrical fire, an open fuse or circuit breaker, or for any other reason. In the event of AC power failure, the battery will supply power for a minimum of 24 hours.

**Smoke/CO alarms may not sense fire that starts where smoke cannot reach the units** such as in chimneys, in walls, on roofs, or on the other side of closed doors. If bedroom doors are usually closed at night, smoke/CO alarms should be placed in each bedroom as well as in the common hallway between them.

**Smoke/CO alarms also may not sense a fire on another level of a residence or building.** For example, a second-floor device may not sense a first-floor or basement fire. Therefore, **smoke alarms should be placed on every level of a residence or building.**

The horn in your device meets or exceeds current audibility requirements of ANSI/UL 217 and ANSI/UL 2034. However, if the **smoke/CO alarm is located outside a bedroom, it may not wake up a sound sleeper**, especially if the bedroom door is closed or only partly open. If the device is located on a different level of the residence than the bedroom, it is even less likely to awaken people sleeping in the bedroom. In such cases, the National Fire Protection Association recommends that the smoke/CO alarms be interconnected so that a unit on any level of the residence will sound an alarm loud enough to awaken sleepers in closed bedrooms. This can be done by employing a systematic approach by interconnecting smoke/CO alarms together, or by using radio frequency transmitters and receivers.

**All types of smoke/CO alarm sensors have limitations. No type of device can sense every kind of fire every time. These types of fires include:**

- 1) Fires where the victim is intimate with a flaming initiated fire; for example, when a person's clothes catch on fire while cooking.
- 2) Fires where the smoke is prevented from reaching the smoke/CO alarm due to a closed door or other obstruction.
- 3) Incendiary fires where the fire grows so rapidly that an occupant's egress is blocked even with properly located smoke/CO alarms.

In general, smoke/CO alarms may not always warn you about fires caused by violent explosions, escaping gas, improper storage of flammable materials, or arson.



**NOTICE:** THIS SMOKE/CO ALARM IS NOT DESIGNED TO REPLACE SPECIAL-PURPOSE FIRE DETECTION AND ALARM SYSTEMS NECESSARY TO PROTECT PERSONS AND PROPERTY IN NON-RESIDENTIAL BUILDINGS SUCH AS WAREHOUSES, OR OTHER LARGE INDUSTRIAL OR COMMERCIAL BUILDINGS. IT ALONE IS NOT A SUITABLE SUBSTITUTE FOR COMPLETE FIRE-DETECTION SYSTEMS DESIGNED TO PROTECT INDIVIDUALS IN HOTELS AND MOTELS, DORMITORIES, HOSPITALS, OR OTHER HEALTH AND SUPERVISORY CARE AND RETIREMENT HOMES. PLEASE REFER TO NFPA 101, THE LIFE SAFETY CODE, AND NFPA 72 FOR SMOKE ALARM REQUIREMENTS FOR FIRE PROTECTION IN BUILDINGS NOT DEFINED AS "HOUSEHOLDS."

Installing smoke/CO alarms may make you eligible for lower insurance rates, but **smoke/CO alarms are not a substitute for insurance.** Home owners and renters should continue to insure their lives and property.

**NOTICE: GENERAL LIMITATIONS OF SMOKE/CO ALARMS**

This smoke/CO alarm is intended for all dwelling units. It is not intended for use in industrial applications where Occupational Safety and Health Administration (OSHA) requirements for carbon monoxide detectors must be met.

**Smoke/CO alarms may not awaken all individuals.** If children and others do not readily awaken to the sound of the smoke/CO alarm or if there are infants or family members with mobility limitations, make sure that someone is assigned to assist them in the event of an emergency.

**Smoke/CO alarms will not work without power.** This smoke/CO alarm requires a continuous supply of power.

**Smoke/CO alarms for solar or wind energy users and battery back-up power systems:** AC powered smoke/CO alarms should only be operated with true or pure sine wave inverters. Operating this device with most battery powered UPS (uninterruptible power supply) products or square wave or "quasi sine wave" inverters will **damage the alarm.** If you are not sure about your inverter or UPS type, please consult with the manufacturer to verify.

**This smoke/CO alarm will not sense carbon monoxide that does not reach the sensor.** This device will only sense CO at the sensor. CO may be present in other areas. Doors or other obstructions may affect the rate at which CO reaches the alarm. For this reason, if sleeping room doors are usually closed at night, we recommend you install an alarm in each sleeping room and in the hallway of each sleeping area.

**Smoke/CO alarms may not sense CO on another level of the residence.** For example, an alarm on the second floor, near the bedrooms may not sense CO in the basement. For complete coverage, it is recommended that an alarm be installed on each level.

**Smoke/CO alarms may not be heard.** The alarm decibel rating meets or exceeds current UL Standards of 85dBA at 10 feet (3 meters). However if the device is installed outside the sleeping area, it may not awaken a sound sleeper, one who has recently used drugs or has been drinking alcoholic beverages. This is especially true if the door is closed or only partially open. Even persons who are awake may not hear the sounding alarm if the sound is blocked by distance or closed doors. Noise from traffic, stereo, radio, television, air conditioner, or other appliances may also prevent alert persons from hearing the alarm horn. This device is not intended for people who are hearing impaired.

**Smoke/CO alarms are not a substitute for life insurance.** Though these devices warn against increasing CO levels, Gentex Corporation does not warrant or imply in any way that they will protect lives from CO poisoning. Homeowners and renters must still insure their lives.

**Smoke/CO alarms have a limited life.** Although the device and all of its components have passed many stringent tests and are designed to be as reliable as possible, any of these parts could fail at any time. Therefore, you must test your smoke/CO alarm weekly.

**Smoke/CO alarms are not foolproof.** Like all other electrical devices, smoke/CO alarms have limitations. They can only detect CO that reaches their sensors. They may not give early warning to rising CO levels if the CO is coming from a remote part of the home, away from the alarm. **NOTICE: SMOKE/CO ALARMS MAY NOT ALARM WHEN A LARGE INFLUX OF CO IS INTRODUCED INTO THE HOUSE.** An example of a possible source of a large in-rush of CO is a generator running in an attached, enclosed garage and the door to the connected residence is opened.

**WHAT YOU NEED TO KNOW ABOUT CO**

**WHAT IS CO?** Carbon Monoxide (CO) is an invisible, odorless, tasteless gas produced when fossil fuels do not burn completely or are exposed to heat (usually fire). Electrical appliances typically do not produce CO.

**These fuels include:** wood, coal, charcoal, oil, natural gas, gasoline, kerosene and propane.

Common appliances are often sources of CO. If they are not properly maintained, are improperly ventilated, or malfunction, CO levels can rise quickly. CO is a real danger now that homes are more energy efficient. "Air-tight" homes with added insulation, sealed windows and other weatherproofing can 'trap' CO inside.

EXPOSURE	SYMPTOMS OF CO POISONING
Mild	Slight headache, nausea, vomiting, fatigue (flu-like symptoms)
Medium	Throbbing headache, drowsiness, confusion, rapid heart rate
Extreme	Convulsions, unconsciousness, heart and lung failure. Exposure to carbon monoxide (CO) can cause brain damage and death

**SYMPTOMS OF CO POISONING:** These symptoms are related to CO POISONING and should be discussed with ALL household members.

**WARNING** Some individuals are more sensitive to CO than others, including people with cardiac, respiratory or other health problems. Infants, young children, pregnant women and elderly people can be more quickly and severely affected by CO. People sensitive to CO should consult their doctors for advice on taking additional precautions.

**FINDING THE SOURCE OF CO AFTER AN ALARM**

Carbon monoxide is an odorless, invisible gas, which often makes it difficult to locate the source of CO after an alarm. A few factors that can make it difficult to locate sources of CO include:

- House well ventilated before the investigator arrives.
- Problem caused by "backdrafting".
- Transient CO problem caused by special circumstances.

Because CO may dissipate by the time an investigator arrives, it may be difficult to locate the source of CO. **Gentex Corporation shall not be obligated to pay for any carbon monoxide (CO) investigation or service call.**

**HOW CAN I PROTECT MY FAMILY?**

A smoke/CO alarm is an excellent way of protection. It monitors the air and sounds a loud alarm before carbon monoxide (CO) levels become threatening for average, healthy adults.

**NOTICE:** A SMOKE/CO ALARM IS NOT A SUBSTITUTE FOR PROPER MAINTENANCE OF HOME APPLIANCES.

To help prevent CO problems and reduce the risk of CO poisoning:

- Clean chimneys and flues yearly. Keep them free of debris, leaves, and nests for proper air flow. Also, have a professional check for rust and corrosion, cracks or separations. These conditions can prevent proper air movement and cause backdrafting. Never cap or cover a chimney in any way, that would block air flow.
- Test and maintain all fuel-burning equipment annually. Many local gas or oil companies and HVAC companies offer appliance inspections for a nominal fee.
- Make regular visual inspections of all fuel-burning appliances. Check appliances for excessive rust and scaling. Also check the flame on the burner and pilot lights. The flame should be blue. A yellow flame means fuel is not being burned completely and CO may be present. Keep the blower door on the furnace closed. Use vents or fans when they are available on all fuel-burning appliances. Make sure appliances are vented to the outside. Do not grill or barbecue indoors, in garages or on screen porches.
- Check for exhaust backflow from CO sources. Check the draft hood on an operating furnace for a backdraft. Look for cracks on furnace heat exchangers.
- Check the house or garage on the other side of shared wall.
- Keep windows and doors open slightly. If you suspect that CO is escaping into your home, open a window or door. Opening windows or doors can significantly reduce CO levels.

**POTENTIAL SOURCES OF CO IN RESIDENTIAL DWELLINGS**

**Fuel-burning appliances like:** portable heater, gas or wood burning fireplace, gas kitchen range or cooktop, gas clothes dryer, portable generators.

**Damaged or insufficient venting:** corroded or disconnected water heater vent pipe, leaking chimney pipe or flue, or cracked heat exchanger, blocked or clogged chimney opening.

**Improper use of appliance/device:** operating a barbecue grill, portable generator or vehicle in an enclosed area (like a garage or screened porch), or even your home.

FIGURE 1

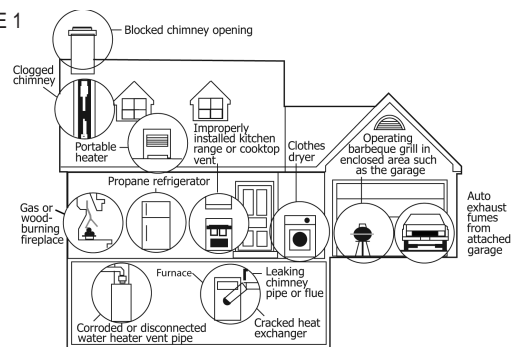

FIGURE 1: POTENTIAL SOURCES OF CO IN HOME

**Transient CO Problems:** transient or on-again-off-again CO problems can be caused by outdoor conditions and other special circumstances.

**The following conditions can result in transient CO situations:**

- 1) Excessive spillage or reverse venting of fuel appliances caused by outdoor conditions such as:
    - ♦ Wind direction and/or velocity, including high, gusty winds. Heavy air in vent pipes (cold/humid air with extended periods between cycles)
    - ♦ Negative pressure differential resulting from the use of exhaust fans
    - ♦ Several appliances running at the same time competing for limited fresh air
    - ♦ Vent pipe connections vibrating loose from clothes dryers, furnaces or water heaters
    - ♦ Obstructions in or unconventional vent pipe designs which can amplify the above situations
  - 2) Extended operation of unvented fuel burning devices (range, oven, fireplace)
  - 3) Temperature inversions, which can trap exhaust close to the ground.
  - 4) Car idling in an open or closed garage or near a home.
  - 5) Portable generator used in an open or closed garage or near a home.
- These conditions can come and go. They are also hard to recreate during a CO investigation.

**PLACEMENT OF SMOKE/CO ALARMS**

THIS EQUIPMENT SHOULD BE INSTALLED IN ACCORDANCE WITH THE NATIONAL FIRE PROTECTION ASSOCIATION'S STANDARD 72 (National Fire Protection Association, Batterymarch Park, Quincy, MA 02269).

For your information, the National Fire Protection Association's Standard 72, reads as follows:

**PLACEMENT OF SMOKE ALARMS**

THIS EQUIPMENT SHOULD BE INSTALLED IN ACCORDANCE WITH THE NATIONAL FIRE PROTECTION ASSOCIATION'S STANDARD 72 (National Fire Protection Association, Batterymarch Park, Quincy, MA 02269).

For your information, the National Fire Protection Association's Standard 72, reads as follows:

NFPA 72, 2010 Edition, Chapter 29, Section 29.5.1 Required Detection, states the following:

**29.5.1.1** Where required by applicable laws, codes or standards for a specific type of occupancy, approved single and multiple-station smoke alarms shall be installed as follows:

- 1) In all sleeping rooms and guest rooms
- 2) Outside of each separate dwelling unit sleeping area, within 6.4m (21ft) of any door to a sleeping room, the distance measured along a path of travel
- 3) On every level of a dwelling unit, including basements
- 4) On every level of a residential board and care occupancy (small facility), including basements and excluding crawl spaces and unfinished attics
- 5) In the living area(s) of a guest suite
- 6) In the living area(s) of a residential board and care occupancy (small facility)

**29.5.1.2** Where the area addressed in 29.5.1.1(2) is separated from the adjacent living areas by a door, a smoke alarm shall be installed in the area between the door and the sleeping room, and additional alarms shall be installed on the living area side of the door as specified by 29.5.1.1 and 29.5.1.3.

**29.5.1.3** In addition to the requirements of 29.5.1.1(1) through 29.5.1.1(3), where the interior floor area for a given level of a dwelling unit, excluding garage areas, is greater than 93m<sup>2</sup> (1000ft<sup>2</sup>), smoke alarms shall be installed per 29.5.1.3.1 and 29.5.1.3.2.

**29.5.1.3.1** All points on the ceiling shall have a smoke alarm within a distance of 9.1m (30ft) travel distance or shall have an equivalent of one smoke alarm per 46m<sup>2</sup> (500ft<sup>2</sup>) is evaluated by dividing the total interior square footage of floor area per level by 46m<sup>2</sup> (500ft<sup>2</sup>).

**29.5.1.3.2** Where dwelling units include great rooms or vaulted/cathedral ceilings extending over multiple floors, smoke alarms located on the upper floor that are intended to protect the aforementioned area shall be permitted to be considered as part of the lower floor(s) protection scheme used to meet the requirements of 29.5.1.3.1.

The installation of additional alarms of either the smoke, heat or CO type should result in a higher degree of protection. Adding alarms to rooms that are normally closed off from the required alarms increases the escape time because the fire does not need to build to the higher level necessary to force smoke out of the closed room to the required alarms. As a consequence, it is recommended that the householder consider the installation of additional fire protection devices. However, it should be understood that NFPA 72 does not require additional smoke alarms over and above those called for in FIGURES 2, 3, 4 and 5 where required smoke alarms are shown.

FIGURE 2

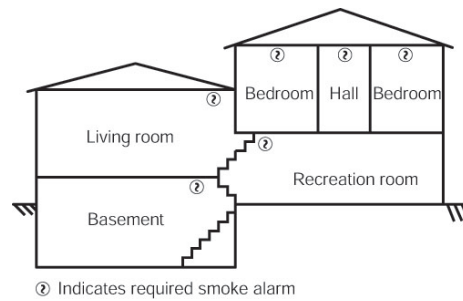

FIGURE 2: A SMOKE ALARM MUST BE LOCATED ON EVERY LEVEL OF DWELLING UNIT, INCLUDING BASEMENT, WITHIN EACH SLEEPING ROOM AND OUTSIDE SLEEPING AREAS.

*Where to Locate the Required Smoke Alarms.* The major threat from fire in a dwelling unit occurs at night when everyone is asleep. Persons in sleeping areas can be threatened by fires in the remainder of the unit; therefore, smoke alarms are best located in each bedroom and between the bedroom areas and the rest of the unit as shown in FIGURE 3.

FIGURE 3

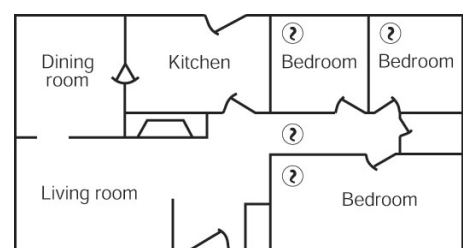

FIGURE 3: A SMOKE ALARM MUST BE LOCATED BETWEEN THE SLEEPING AREA AND THE REST OF THE DWELLING UNIT AS WELL AS IN EACH BEDROOM.

In dwelling units with more than one bedroom area or with bedrooms on more than one floor, more than one smoke alarm is required, as shown in FIGURE 4.

FIGURE 4

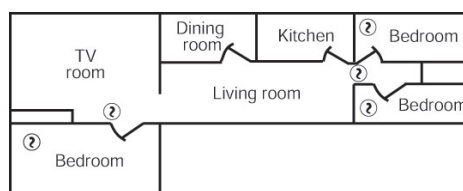

FIGURE 4: IN DWELLING UNITS WITH MORE THAN ONE SLEEPING AREA, A SMOKE ALARM MUST BE PROVIDED TO PROTECT EACH SLEEPING AREA IN ADDITION TO SMOKE ALARMS REQUIRED IN BEDROOMS.

In addition to smoke alarms outside of the sleeping areas and in each bedroom, NFPA 72 requires the installation of a smoke alarm on each additional level of the dwelling unit, including the basement. These installations are shown in FIGURE 5. The living area smoke alarm should be installed in the living room or near the stairway to the upper level, or in both locations. The basement smoke alarm should be installed in close proximity to the stairway leading to the floor above. Where installed on an open-joisted ceiling, the smoke alarm should be placed on the bottom of the joists. The smoke alarm should be positioned relative to the stairway so as to intercept smoke coming from a fire in the basement before the smoke enters the stairway.

FIGURE 5

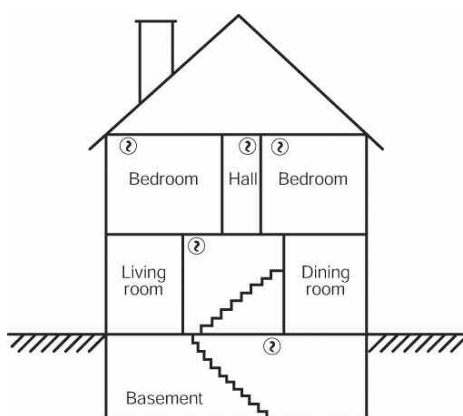

FIGURE 5: A SMOKE ALARM MUST BE LOCATED ON EACH LEVEL IN ADDITION TO EACH BEDROOM.

## IMPORTANT CONSIDERATION

NFPA states the following for replacement of smoke/CO alarms: NFPA 720, 2012 Edition, Chapter 8, Section 8.8.1.3 states: Smoke/CO alarms shall be replaced when either the end-of-life signal is activated or the manufacturer's replacement date is reached. Alarms shall also be replaced when they fail to respond to operability tests.

**Smoke/CO alarms must be replaced when end of life signal sounds, why:**

- Dust, dirt, and other environmental contaminants can affect your smoke/CO alarm over a prolonged period.
- Fast changing industry consensus standards and codes on all smoke/CO alarms make it advisable to periodically upgrade your smoke/CO alarm to maximize life safety.
- Assurance that your smoke/CO alarm needs are kept abreast with the constantly improving electronic technology.
- Smoke/CO alarms are recognized as one of the lowest cost ways to protect dwelling inhabitants against the danger of fire and CO. It makes good common sense to periodically replace and update your smoke/CO alarm that contributes so much to life safety.

## MOUNTING LOCATION

This smoke/CO alarm can be mounted on a ceiling or wall with equal efficiency in either location.

- Ceiling location - smoke/CO alarm should be mounted as close as possible to the center of a hallway or room.
- Wall location - locate the top of the smoke/CO alarm not more than 12 inches from the ceiling.

FIGURE 6



FIGURE 6: RECOMMENDED SMOKE/CO ALARM MOUNTING LOCATIONS

FIGURE 7

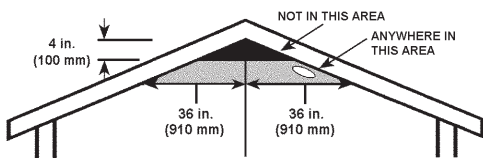

FIGURE 7: RECOMMENDED SMOKE/CO ALARM LOCATION IN ROOMS WITH SLOPED, GABLED, OR PEAKED CEILINGS.

The placement of the smoke/CO alarm is critical if maximum speed of fire detection is desired. Thus, a logical location for a smoke alarm is the center of the ceiling. At this location, the device is closest to all areas of the room.

## WHERE ALARMS SHOULD BE INSTALLED IN MOBILE HOMES

In mobile homes built after about 1978 that were designed and insulated to be energy-efficient, smoke/CO alarms should be installed as described in the section above.

In older mobile homes that have little or no insulation compared to today's standards, uninsulated metal outside walls and roofs can transfer heat and cold from outdoors, making the air right next to them hotter or colder than the rest of the inside air. These layers of hotter or colder air can prevent smoke from reaching a smoke/CO alarm. Therefore, install devices in such units only on inside walls, not more than 12 inches (30 cm) from the ceiling. If you are not sure about the insulation level in your mobile home, or if you notice that the walls or ceiling are unusually hot or cold, install the device on an inside wall.

Minimum protection requires one smoke/CO alarm as close to the sleeping area as possible. For better protection, install one device in each room, but first read the "Locations to Avoid."

## LOCATIONS TO AVOID

Nuisance alarms are caused by placing smoke/CO alarms where they will not operate properly. To avoid nuisance alarms, **do not place smoke/CO alarms:**

- **In or near areas where combustion particles are normally present** such as **kitchens**; in **garages** where there are particles of combustion in vehicle exhausts; **near furnaces, hot water heaters, or gas space heaters**. Install smoke/CO alarms at least 20 feet (6 meters) away from kitchens and other areas where combustion particles are normally present.
- **In air streams passing by kitchens**. Figure 8 shows how a smoke/CO alarm can be exposed to combustion particles in normal air movement paths, and how to correct this situation.

FIGURE 8

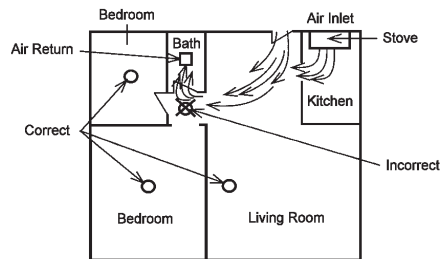

- **In damp or very humid areas**, or next to bathrooms with showers. The moisture in humid air can enter the sensing chamber as water vapor, then cool and condense into droplets that cause a nuisance alarm. **Install smoke/CO alarms at least 10 feet (3 meters) away from bathrooms.**
- **In very cold or very hot environments, or in unheated buildings or outdoor rooms**, where the temperature can go below or above the operating range of the smoke alarm. Temperature limits for proper operation are 40° to 100°F (4.4° to 37.8°C).
- **In very dusty or dirty areas**. Dust and dirt can build up on the smoke alarm's sensing chamber and can make it overly sensitive, or block openings to the sensing chamber and keep the smoke alarm from sensing smoke.
- **Near fresh air inlets, returns or excessively drafty areas**. Air conditioners, heaters, fans, fresh air intakes and returns can drive smoke away from smoke/CO alarms, making the devices less effective.
- **In dead air spaces at the top of a peaked roof or in the corners between ceilings and walls**. Dead air may prevent smoke from reaching a smoke alarm. See Figures 6 and 7 for recommended mounting locations.
- **In insect-infested areas**. If insects enter a smoke/CO alarm's sensing chamber, they may cause a nuisance alarm. **Get rid of the bugs before installing smoke/CO alarms where bugs are a problem.**
- **Near fluorescent light fixtures**. Electrical "noise" from nearby fluorescent light fixtures may cause a nuisance alarm. **Install smoke/CO alarms and fluorescent lights on separate electrical circuits.**

**⚠ WARNING** Never disconnect an AC smoke/CO alarm to silence a nuisance alarm. Open a window or fan the air around the device to remove the smoke. The alarm will automatically turn off when the smoke in the air is completely gone. Do not stand close to the device. The sound produced by the smoke alarm is loud because it is designed to awaken you in an emergency. Prolonged exposure to the horn at a close distance may be harmful to your hearing.

## WHERE SMOKE/CO ALARMS SHOULD NOT BE INSTALLED DO NOT INSTALL THIS CO ALARM:

- In garages, kitchens, furnace rooms, or in any extremely dusty, dirty or greasy areas.
- Closer than 15 feet (4.6 meters) from a furnace or other fuel burning heat source or fuel burning appliance like a water heater.
- Within 5 feet (1.5 meters) of any cooking appliance
- Near any type of diaper pails or receptacle.
- Near animal litter boxes, cages or kennels.
- In extremely humid areas. This alarm should be at least 10 feet (3 meters) from a bath or shower, sauna, humidifier, vaporizer, dishwasher, laundry room, utility room or other source of high humidity.
- In areas where temperature is colder than 40°F (4°C) or hotter than 100°F (38°C). These areas include non-air conditioned crawl spaces, unfinished attics, uninsulated or poorly insulated ceilings, porches and garages.
- In turbulent air, like near ceiling fans, heat vents, air conditioners, fresh air returns, or open windows. Blowing air may prevent CO from reaching the sensors.
- In direct sunlight

Figures 2, 3, 4 & 5 are reprinted with permission from NFPA 72, National Fire Alarm Code®, Copyright ©2010, National Fire Protection Association, Quincy, MA 02169. This reprinted material is not the complete and official position of the National Fire Protection Association on the referenced subject which is represented only by the standard in its entirety. National Fire Alarm Code® and NFPA 72® are registered trademarks of the National Fire Protection Association, Inc., Quincy, MA 02169.



## ⚠ WARNING

### IMPORTANT SAFETY MESSAGES

- This smoke/CO alarm is designed for use inside a single or multi-family dwelling. It is not meant to be used in common lobbies, hallways, or basements of multi-family buildings unless working alarms are also installed in each family living unit. Smoke/CO alarms in common areas may not be heard from inside individual family living units.
- This smoke/CO alarm is not a suitable substitute for complete detection systems in places which house many people like hotels or dormitories, unless a smoke/CO alarm is also placed in each unit.
- DO NOT use this smoke/CO alarm in warehouses, industrial or commercial buildings, special-purpose non-residential buildings or airplanes. This smoke/CO alarm is specifically designed for residential use and may not provide adequate protection in non-residential applications.

**⚠ WARNING** Never disconnect an AC CO alarm to silence a nuisance alarm. Open a window or fan the air around the CO alarm. The alarm will automatically turn off when the CO in the air is completely gone. Do not stand close to the CO alarm. The sound produced by the CO alarm is loud because it is designed to awaken you in an emergency. Prolonged exposure to the horn at a close distance may be harmful to your hearing.

### BATTERY INSTALLATION

1. Locate side mounted battery drawer.
2. Open battery drawer by firmly pulling on side lip, then sliding battery drawer open.
3. Insert battery into drawer, terminal end first. Take care to make sure the proper polarity is being observed, (+) terminal on battery to (+) terminal on alarm metal contact and (-) terminal on battery to (-) terminal on the alarm metal contact. See FIGURE 9.
4. Insert battery into drawer and close drawer. Note: the battery drawer will not close if the battery is installed incorrectly.
5. Slide battery drawer shut until it is snapped into place.
6. Use only Duracell® MN 1604 battery with the GN-503 Series smoke/CO alarm. Available at many retail stores.
7. Push test button to verify battery operation.

**NOTICE:** UNITS WITH BATTERY BACK-UP WILL NOT PROVIDE POWER OR TRANSMIT AN ALARM TO OTHER AC ONLY UNITS IN THE EVENT OF AN AC POWER FAILURE. ALL BATTERY BACK-UP UNITS IN TANDEM WITH GOOD BATTERIES WILL OPERATE NORMALLY DURING AN AC POWER FAILURE A MINIMUM OF 24 HOURS.

FIGURE 9

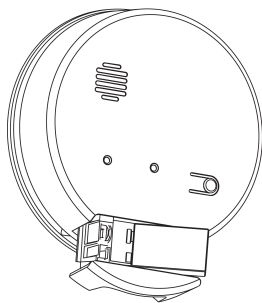

### MOUNTING: PLATE & SMOKE/CO ALARM

1. Lace the connector through the provided mounting plate and secure the plate to the junction box.
2. Plug the wire connector into the smoke/CO alarm base.

FIGURE 10

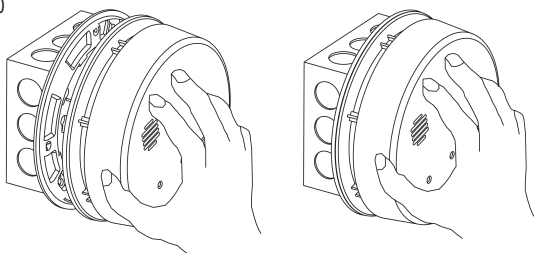

3. Place device up to mounting plate, rotating it clockwise until device firmly snap locks into place. Keep smoke alarm parallel to the mounting plate so tabs on plate seat correctly into device.
4. Remove dust-cover after all construction is complete. Dust-cover must be removed prior to power being supplied to the smoke/CO alarm. If the dust-cover is not removed, operation of smoke/CO alarm will be inhibited.

FIGURE 11

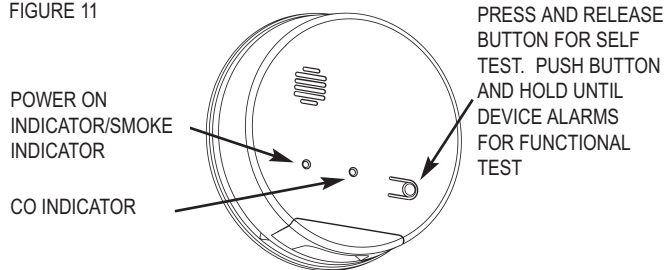

**NOTICE:** REMOVE DUST-COVER BEFORE OPERATING SMOKE/CO ALARM

### CHECKOUT & TROUBLESHOOTING

- For self test feature, press and release button. Results of test:
  - ♦ Alarm is silent - Smoke/CO Alarm is in good working condition
  - ♦ 1 Chirp with red LED flash - Low battery. Replace battery following instructions in BATTERY INSTALLATION Section
  - ♦ 2 Chirps with red LED flash - Smoke/CO Alarm has become dirty or defective or there is a large influx of CO. Clean (refer to MAINTENANCE Section) or warranty return.
  - ♦ 3 Chirps with red LED flash - Smoke/CO Alarm is at end of life and must be replaced.
- To find device with low battery (1 chirp) or device that has become dirty or defective (2 chirps) perform the self test and the faulty alarm will continue to chirp as long as fault is present.
- ♦ Press and hold button until all alarms annunciate for functional test
- ♦ Supply house power to the smoke/CO alarm, green indicator will be on. The red indicator light should flash approximately every 15-30 seconds, showing that unit is operating properly.
- ♦ If red light is not flashing or the green LED is not on:
  - a. Check that AC power is working.
  - b. Check that the battery is installed.
  - c. Push test button. Alarm will go into self test mode.
  - d. Check the connector plug and wire connections.  
**NOTICE:** BE SURE YOU TURN OFF POWER BEFORE CHECKING WIRE CONNECTIONS.
  - e. If the power supply and wiring check out, but the red light does not flash or the green LED is still off, return the unit to the manufacturer. See TO RETURN AN ALARM.
- ♦ When powering up devices in a tandem installation inspect all devices for a solid green LED and all devices sound when each device is tested. If problem exists verify wiring of devices. If wiring is correct and problem remains, the device(s) with flashing red LED is the trouble device(s) and should be replaced.
- ♦ If smoke/CO alarm becomes contaminated, such as excessive dust, and can not be cleaned, avoid nuisance alarms by replacing device.

### ⚠ WARNING IF YOUR SMOKE/CO ALARM SOUNDS

Actuation of the smoke/CO alarm, sounding for CO, (temporal 4 tone) indicates the presence of carbon monoxide (CO) which can kill you. IF THE DEVICE ALARM SOUNDS, DO NOT IGNORE THE UNIT!

#### ⚠ WARNING

**“ALARM - MOVE TO FRESH AIR”**

If you hear the smoke/CO alarm horn and the red light is flashing, move everyone to a source of fresh air. DO NOT unplug the alarm!

#### IF THE ALARM SIGNAL SOUNDS:

1. Operate the Test/Reset button (when the alarm has been reset, the device will continue to monitor the air for the presence of CO. If the alarm sounds again, there are CO levels that are potentially dangerous).
2. Call emergency services, fire department or 911. Write the number of your local emergency service here:
3. Immediately move to fresh air - outdoors or by an open door or window. Meet at prearranged meeting place after leaving the house. Verify all persons are accounted for. Do not re-enter premises or move away from the fresh air until the emergency responder has arrived, the premises has been aired out and the smoke/CO alarm remains in normal condition.
4. After following steps 1-3, if the smoke/CO alarm reactivates within a 24-hour period, repeat steps 1-3 and call a qualified appliance technician to investigate for sources of CO from fuel-burning equipment and appliances as well as inspect for proper operation of this equipment. If problems are identified during this inspection, have the equipment serviced immediately. Note any combustion

equipment not inspected by the technician and consult the manufacturers' instructions, or contact the manufacturers directly for more information about CO safety and this equipment. Make sure that motor vehicles are not and have not been operating in an attached garage or adjacent to the residence. Write down the number of a qualified appliance technician here:

**NOTICE:** ALARMS HAVE VARIOUS LIMITATIONS. SEE "GENERAL LIMITATIONS OF SMOKE/CO ALARMS" FOR DETAILS.

## USING THE RESET FEATURE

### WARNING

- The reset feature is for your convenience only and will not correct a CO problem. ALWAYS check your home for a potential problem after any alarm. Failure to do so can result in injury or death.
- NEVER remove the battery from your alarm to silence the horn; use the reset feature. Removing the battery, removes your protection! See "IF YOUR SMOKE/CO ALARM SOUNDS" for details on responding to an alarm.

The reset feature is intended to reset the CO alarm while the problem is corrected - **IT WILL NOT CORRECT A CO PROBLEM.**

While the alarm has been reset, the device will continue to monitor the air for the presence of CO.

When CO reaches alarm levels, the alarm will sound a temporal 4 horn pattern - 4 beeps, a pause, 4 beeps, a pause, etc. Press the reset button until the horn becomes silent. The initial reset cycle will last approximately 5 minutes.

**NOTICE:** AFTER INITIAL 5 MINUTE RESET CYCLE, THE ALARM WILL RE-EVALUATE PRESENT CO LEVELS AND RESPOND ACCORDINGLY. IF CO LEVELS REMAIN POTENTIALLY DANGEROUS, OR INCREASE TO HIGHER LEVELS, THE ALARM WILL SOUND AGAIN.

#### While the alarm is silenced:

If the smoke/CO alarm:	This means:
Is silent for only 5 minutes, then the alarm sounds again	CO levels are still potentially dangerous
If the smoke/CO alarm:	This means:
Remains silent after the reset button has been pressed	CO levels are dropping

TROUBLESHOOTING GUIDE		
PROBLEM:	THIS MEANS:	ACTION TAKEN:
Smoke/CO alarm goes back into alarm 5 minutes after the reset button was pressed.	CO levels indicate a potentially dangerous situation.	IF YOU ARE FEELING SYMPTOMS OF CO POISONING, EVACUATE your home and call 911 or the Fire Department. If not, press the reset button again and <b>keep ventilating your home.</b>
Green light is OFF. Red light is not flashing. Unit will not go into test mode when reset button is pressed.	Device may not be receiving power. NO AC and no battery in device	Contact licensed electrical technician for equipment inspection service, immediately.
Alarm sounds 2 quick chirps every 30 seconds.	Device has become dirty or defective.	Clean (refer to MAINTENANCE Section) or TO RETURN AN ALARM Section
Alarm sounds 3 quick chirps every 30 seconds.	<b>END OF LIFE SIGNAL.</b> Replace device.	Contact Gentex Corporation for replacement information or see TO RETURN AN ALARM Section.
Green light is ON and red light is not flashing and alarm chirps once every 30 seconds	Low or no battery in device. AC is powering device	Replace battery (refer to Battery Installation Section) or return to manufacturer
Reset button is pressed. LED's do not flash and device does not go into test mode.	Device is not operating properly.	Contact Gentex Corporation for replacement information or see TO RETURN AN ALARM Section.
Only CO portion of device is operating.	Smoke portion of device is not operating properly.	Contact Gentex Corporation for replacement information or see TO RETURN AN ALARM Section.
Any questions that are not answered within this manual, call Gentex Corporation at 1-800-436-8391.		

## MAINTENANCE

### NOTICES:

- DO NOT OPEN SMOKE/CO ALARM FOR CLEANING. IF SMOKE/CO ALARM IS OPENED, PRODUCT WARRANTY BECOMES VOID.
- IF THE DEVICE DOES NOT WORK PROPERLY, DO NOT TRY AND FIX IT YOURSELF. THIS WILL VOID YOUR WARRANTY. SEE TO RETURN AN ALARM SECTION FOR INSTRUCTIONS TO RETURN SMOKE ALARMS THAT DO NOT OPERATE PROPERLY. DO NOT TRY TO FIX IT YOURSELF.

Gentex recommends CO alarms be tested a minimum of once a week. The test feature of your CO alarm accurately simulates CO conditions and tests the CO alarm's functions as required by ANSI/UL 217 and ANSI/UL 2034.

### NOTICES:

- NEVER USE AN OPEN FLAME OF ANY KIND TO TEST YOUR DEVICE. YOU MAY IGNITE AND DAMAGE THE SMOKE/CO ALARM AS WELL AS YOUR HOME. THE TEST FEATURE OF YOUR SMOKE/CO ALARM ACCURATELY SIMULATES SMOKE CONDITIONS AND TESTS THE DEVICE'S FUNCTIONS AS REQUIRED BY UNDERWRITERS LABORATORIES.
- DO NOT COVER, TAPE, OR OTHERWISE BLOCK THE OPENINGS OF YOUR SMOKE/CO ALARM. THESE OPENINGS ARE DESIGNED TO ALLOW AIR TO PASS THROUGH YOUR SMOKE/CO ALARM, THUS SAMPLING THE AIR AROUND THE SMOKE/CO ALARM.
- SMOKE/CO ALARMS ARE NOT TO BE USED WITH DETECTOR GUARDS UNLESS THE COMBINATION HAS BEEN EVALUATED BY A NATIONALLY RECOGNIZED TESTING LABORATORY AND FOUND SUITABLE FOR THAT PURPOSE.
- FAILURE TO REGULARLY CLEAN THIS SMOKE/CO ALARM WILL RESULT IN FALSE ALARMS. A BUILD UP OF DUST CREATES AN OBSCURATION THAT SIMULATES SMOKE. THIS MEANS THE UNIT WILL GO INTO ALARM WITH OUT A FIRE CONDITION.

## WEEKLY TESTING

Press the test/reset button on the alarm until the alarm sounds. During testing the device will simulate a smoke condition in the alarm followed by an electrical test of the CO sensor. LED's will flash to indicate testing. The alarm sequence should last 10-20 seconds.

### WARNING

- If the alarm ever fails to test properly, replace it immediately. Products under warranty may be returned to the manufacturer for replacement, see LIMITED WARRANTY.
- DO NOT stand close to the device when the alarm is sounding. Exposure at close range could result in hearing damage.
- Never use exhaust from vehicle to test CO portion of alarm. Exhaust may cause permanent damage to alarm and voids the warranty.

#### TO KEEP THE ALARM WORKING PROPERLY:

- Test weekly as described in WEEKLY TESTING.
- Keep alarm cover clean using soft cloth. DO NOT vacuum or use compressed air, water, cleaners or solvents to clean alarm.
- Replace battery immediately if low battery warning is heard. See BATTERY INSTALLATION section.

**NOTICE:** DO NOT SPRAY CLEANING CHEMICALS OR INSECT SPRAYS DIRECTLY ON OR NEAR THE ALARM. DO NOT PAINT OVER THE ALARM. DOING SO MAY CAUSE PERMANENT DAMAGE.

- Household cleaners, aerosol chemicals and other contaminants can affect the sensor. When using any of these materials near the alarm, make sure the room is well ventilated.

**NOTICE:** THE CO ALARM IS NOT WASHABLE. DO NOT SUBMERGE THE ALARM IN WATER. WATER CAN AFFECT THE SENSOR, CAUSING PERMANENT DAMAGE.

- If your home is being fumigated, disconnect unit temporarily from wire harness and store where it will not be exposed to chemicals or fumes. When fumigation is complete and all traces of fumes clear, re-connect unit back to wire harness and push the reset button.

## UNDERWRITERS LABORATORIES, INC. ANSI/UL 2034 WHAT LEVELS OF CO CAUSE AN ALARM

UL Standard ANSI/UL 2034 requires residential smoke/CO alarms to sound when exposed to levels of CO and exposure times as described below. CO levels are measured in part per million (ppm) of CO over time (in minutes).

#### ANSI/UL 2034 Required Alarm Points:

- If the smoke/CO alarm is exposed to 400 ppm of CO, THE DEVICE MUST ALARM BETWEEN 4 - 15 MINUTES.
- If the smoke/CO alarm is exposed to 150 ppm of CO, THE DEVICE MUST ALARM BETWEEN 10 - 50 MINUTES.
- If the smoke/CO alarm is exposed to 70 ppm of CO, THE DEVICE MUST ALARM BETWEEN 60 - 240 MINUTES.

The device is designed not to alarm when exposed to a constant level of 30 ppm for 30 days.

1 Approximately 10% COHb exposure at levels of 10% to 95% Relative Humidity (RH).



**▲ WARNING** Smoke/CO alarms are designed to alarm before there is an immediate life threat. Since CO gas cannot be seen or smelled, never assume it is not present.

- ◆ An exposure to 100 ppm of CO for 20 minutes may not affect a healthy adult, after 4 hours of exposure at the same level may cause headache.
- ◆ An exposure to 400 ppm of CO may cause headaches in a healthy adult after 35 minutes and could cause death after 2 hours.

**NOTICE:** THIS DEVICE MEASURES EXPOSURE TO CO OVER TIME. THIS DEVICE ALARMS IF CO LEVELS REACH A CERTAIN MINIMUM OVER AN EXTENDED AMOUNT OF TIME.

The device will go into alarm before the onset of symptoms in healthy adults. It is important to have early notification of a potential hazard, while still having the ability to react in time. In many reported cases of CO exposure, victims may be aware that they were not feeling well, but became disoriented and could no longer react well enough to exit the building or get help.

**NOTICE:** HEALTHY ADULTS MAY NOT EXPERIENCE ANY SYMPTOMS OF CO EXPOSURE WHEN THE DEVICE ALARMS, HOWEVER INFANTS, YOUNG CHILDREN, PREGNANT WOMEN, ELDERLY PEOPLE, PEOPLE WITH CARDIAC, RESPIRATORY OR OTHER HEALTH RELATED ISSUES MAY BE MORE QUICKLY AND SEVERELY AFFECTED BY CO EXPOSURE. IF EVEN THERE ARE MILD SYMPTOMS OF EXPOSURE TO CO POISONING, CONSULT A MEDICAL PROFESSIONAL IMMEDIATELY.

**Standards:** Underwriters Laboratories, Inc. Single and Multiple Station carbon monoxide alarms ANSI/UL 2034. For your information, the ANSI/UL 2034 Standard, reads as follows:

Underwriters Laboratories, Inc ANSI/UL 2034, Section 1-1.2 *Carbon monoxide alarms covered by these requirements are intended to respond to the presence of carbon monoxide from sources such as, but not limited to, exhaust from internal-combustion engines, abnormal operation from fuel-fired appliances and fireplaces. CO alarms are intended to alarm at carbon monoxide levels below those that could cause a loss of ability to react to the dangers of carbon monoxide exposure.*

This alarm monitors the air at the device and is designed to alarm before CO levels become life threatening. This allows precious time to leave the house and correct the problem. This is only possible if the devices are properly located, installed and maintained as described in this manual.

**Gas Detection at Typical Temperature and Humidity Ranges:** This device is not formulated to detect CO levels below 30 ppm typically. ANSI/UL tested for false alarm resistance to Methane (500 ppm), Butane (300 ppm), Heptane (500 ppm), Ethyl Acetate (200 ppm), Isopropyl Alcohol (200 ppm) and Carbon Dioxide (5000 ppm). Values measure gas and vapor concentrations in parts per million.

**Audible Alarm:** 85dBA minimum at 10 feet (3 meters).

## TO RETURN AN ALARM

Should you experience problems with your smoke/CO alarm, proceed as follows:

1. Turn off electrical power to the smoke/CO alarm.
2. Twist the smoke/CO alarm counter-clockwise to remove it from its mounting plate.
3. Unplug the connector from the back of the smoke/CO alarm. Do not remove the wire connection; leave the connector for your replacement smoke/CO alarm.
4. Remove battery from smoke/CO alarm. Do not ship smoke/CO alarm with battery still in battery drawer.
5. Carefully pack (the manufacturer cannot be responsible for consequential damage) and return to the manufacturer. Include complete details as to exact nature of difficulties being experienced and date of installation.
6. Return to: Gentex Corporation, 10985 Chicago Drive, Zeeland, Michigan 49464. Prior to returning, call Gentex at 800-436-839 or e-mail [FP\\_RMA@gentex.com](mailto:FP_RMA@gentex.com) to obtain a RMA Number from our return department.

NOTE: GENTEX LEGACY PRODUCTS INCLUDE 9120, 9123, 7100, 7103, 710CS, 713CS, 7109CS, 7139CS, GN-200, GN-203, GN-300 AND GN-303 SERIES. THESE PRODUCTS WILL NOT ACTIVATE FOR A CO EVENT WHEN TANDEM INTERCONNECTED TO A GENTEX CO OR SMOKE/CO ALARM.

# INSTALLATION INSTRUCTIONS FOR GN-503FF

**NOTICE:** NEW CONSTRUCTION: DO NOT ATTACH SMOKE/CO ALARM HEAD UNTIL AFTER SANDING, PAINTING, AND OTHER DUST CREATING SITUATIONS ARE FINISHED AND CLEANED UP.

## WIRING/GENERAL

1. Use ANSI/UL Listed wire for Class 1 requirements.
2. Observe local code requirements. Use box connector to anchor cable to outlet box.
3. Metal outlet boxes must be grounded to earth ground.

### IMPORTANT GN-503FF PRODUCT INSTALLATION INFORMATION

**NOTICE:** USE ONLY DURACELL® MN 1604 BATTERY WITH THE GN-503 SERIES SMOKE/CO ALARMS. AVAILABLE AT MANY RETAIL STORES.

- ♦ Use brown/yellow wire to tandem interconnect GN-503 Series alarms to additional GN-503 Series, S1209 Series and CO1209 Series.

**NOTICE:** THE GN-503FF IS ONLY CAPABLE OF TANDEM INTERCONNECT WITH GN-503 SERIES, CO1209 SERIES AND S1209 SERIES. IT IS NOT POSSIBLE TO TANDEM INTERCONNECT ANY OTHER GENTEX PRODUCT SERIES THAN WHAT IS LISTED ABOVE

- ♦ **THE GN-503FF AND GN-503F PRODUCT WIRING HARNESS IS NOT INTERCHANGEABLE. THE GN-503FF AND GN-503F MUST USE PROPER WIRING HARNESS. PRODUCT WILL NOT FUNCTION IF INCORRECT HARNESS IS USED.**

**CAUTION:** Turn off electricity to prevent SHOCK and damage to smoke/CO alarm. Be sure the AC power to the smoke/CO alarm is not controlled by any on/off switch, or other type of switch, other than a fuse or circuit breaker.

**IMPORTANT:** Ensure that all fluorescent lighting fixtures are properly grounded. **NOTICE:** THE WIRING TO BE USED SHALL BE IN ACCORDANCE WITH THE PROVISIONS OF ARTICLE 210 OF THE NATIONAL ELECTRICAL CODE, NFPA 70. WIRE INSTALLATION SHOULD BE PERFORMED ONLY BY A LICENSED ELECTRICIAN.

## MOUNTING OUTLET BOX

Use a 2" x 3" switch box or a 4" square or octagon junction box. Mount a box for each smoke/CO alarm. If wall mounting is desired, be sure the box screws are oriented to upper right and lower left corners. Be sure to use supplied Mounting Plate.

## WIRING ONE ALARM

1. Run a minimum of 16 gauge, 2-conductor cable, plus ground (3 wires) to the junction box from a branch circuit. Smoke/CO alarms shall be connected to their own dedicated circuit. Use ANSI/UL Listed wire for Class 1 requirements.

**NOTICE:** THE WIRING TO BE USED SHALL BE IN ACCORDANCE WITH THE PROVISIONS OF ARTICLE 300.3(B) 210 OF THE NATIONAL ELECTRICAL CODE, NFPA 70.

2. Make wire connections to the supplied harness as follows: black to black, white to white, and connect the ground wire to the metal outlet box.

### GN-503FF WIRING DIAGRAM

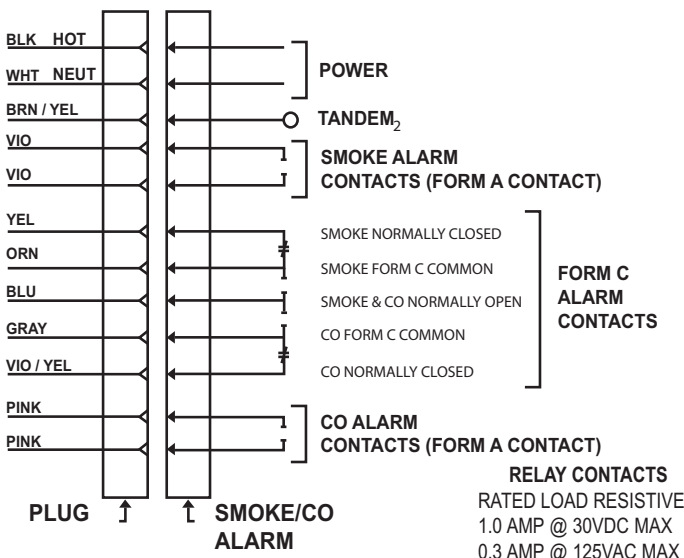

## WIRING TWO OR MORE ALARMS

### Tandem Interconnect Installation

**NOTICE:** ALL SMOKE/CO ALARMS TANDEM INTERCONNECTED MUST BE CONTROLLED BY THE SAME FUSE OR CIRCUIT BREAKER. OTHERWISE TANDEM FEATURE WILL NOT OPERATE. TANDEM INTERCONNECTION WILL OPERATE IN THE EVENT OF AC POWER FAILURE IF BATTERY IS CONNECTED TO THE SMOKE ALARM.

**LIMITATIONS:** A maximum of 12 GN-503FF alarms may be tandem interconnected together. Do not exceed 125 feet between each device. Do not exceed 1125 feet between first and last smoke/CO alarm.

Wire used for tandem interconnection shall be in accordance with article 760 of the latest edition of National Electrical Code (NFPA 70) and must not exceed a resistance of 10 ohms.

1. Run a minimum of 16 gauge, 3-conductor cable, plus ground (4 wires) to the first junction box from a dedicated branch circuit and between all smoke/CO alarms that are to be connected together. Use ANSI/UL Listed wire for Class 1 requirements. Power limited cable for multiple tandem connections are available at many commercial electrical retail stores.
2. Make wire connections to the supplied wire harness as follows: black to black, white to white, 3rd conductor to the brown/yellow wire. The brown/yellow wire should be stripped to make the connection. Connect ground wire between metal outlet boxes.

### NOTES ON TANDEM INTERCONNECTING MODELS

- ♦ **DO NOT** connect Gentex alarms to other manufacturers' alarms.
- ♦ A maximum of 18 compatible smoke, heat, CO and/or combination smoke/CO alarms may be interconnected. No more than 12 of the 18 can be smoke alarms per NFPA 72.
- ♦ No more than 12 Gentex model GN-503FF alarms may be connected in tandem.
- ♦ All alarms tandem interconnected **MUST** get their power from the same dedicated branch circuit, all smoke alarms in tandem must be controlled by the same fuse or circuit breaker.
- ♦ After installation, to verify proper working conditions, all alarms must sound in this system. Test using the functional test button feature.
- ♦ Use brown/yellow wire to tandem interconnect GN-503FF alarms to additional GN-503 Series, S1209 Series and CO1209 Series.

**NOTICE:** IF A GN-503 SERIES OR CO1209 SERIES UNIT IS ANNUNCIATING FOR A CO EVENT, LEGACY PRODUCTS WILL NOT ACTIVATE AND WILL REMAIN SILENT.

**CAUTION:** Failure to observe any of the conditions set forth may cause system malfunction and damage to the device.

### GN-503FF TANDEM INTERCONNECT WIRING DIAGRAM

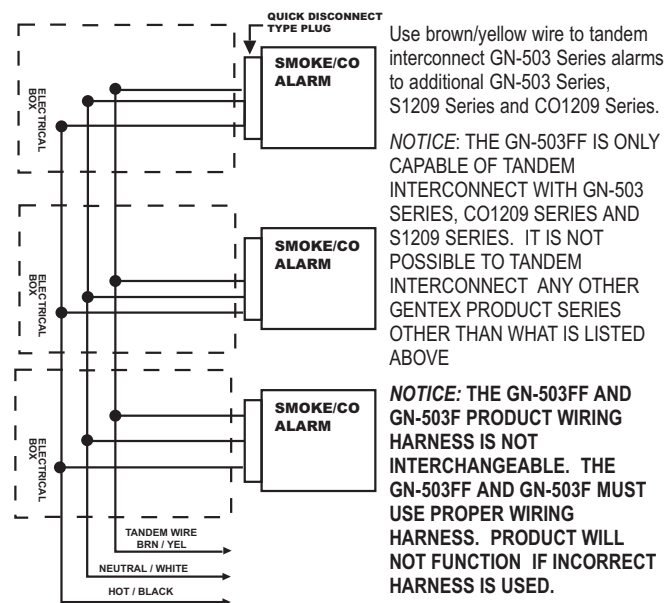

Use brown/yellow wire to tandem interconnect GN-503 Series alarms to additional GN-503 Series, S1209 Series and CO1209 Series.

**NOTICE:** THE GN-503FF IS ONLY CAPABLE OF TANDEM INTERCONNECT WITH GN-503 SERIES, CO1209 SERIES AND S1209 SERIES. IT IS NOT POSSIBLE TO TANDEM INTERCONNECT ANY OTHER GENTEX PRODUCT SERIES OTHER THAN WHAT IS LISTED ABOVE

**NOTICE:** THE GN-503FF AND GN-503F PRODUCT WIRING HARNESS IS NOT INTERCHANGEABLE. THE GN-503FF AND GN-503F MUST USE PROPER WIRING HARNESS. PRODUCT WILL NOT FUNCTION IF INCORRECT HARNESS IS USED.

**NOTICE:** A MAXIMUM OF 12 SMOKE/CO ALARMS OF MODEL GN-503FF MAY BE TANDEM INTERCONNECTED.

**CAUTION:** BROWN/YELLOW wire to be capped when not in use. This wire is for tandem interconnection only. DO NOT connect to any other circuit.

2 The GN-503FF is only compatible of tandem interconnection with GN-503 Series, CO1209 Series and S1209 Series.

# INSTALLATION INSTRUCTIONS FOR GN-503 AND GN-503F ALARMS

**NOTICE: NEW CONSTRUCTION: DO NOT ATTACH SMOKE/CO ALARM HEAD UNTIL AFTER SANDING, PAINTING, AND OTHER DUST CREATING SITUATIONS ARE FINISHED AND CLEANED UP.**

## WIRING/GENERAL

1. Use ANSI/UL Listed wire for Class 1 requirements.
2. Observe local code requirements. Use box connector to anchor cable to outlet box.
3. Metal outlet boxes must be grounded to earth ground.

## IMPORTANT GN-503 AND GN-503F PRODUCT INSTALLATION INFORMATION

**NOTICE: USE ONLY DURACELL® MN 1604 BATTERY WITH THE GN-503 SERIES SMOKE/CO ALARMS. AVAILABLE AT MANY RETAIL STORES.**

- Use brown/yellow wire to tandem interconnect GN-503 Series alarms to additional GN-503 Series, S1209 Series and CO1209 Series.
- **DO NOT USE RED/YELLOW TO INTERCONNECT GN-503 SERIES, S1209 SERIES AND CO1209 SERIES.** If the red/yellow is used to interconnect the GN-503 Series to additional GN-503 Series, S1209 Series and CO1209 Series, the units will not be tandem interconnected. The brown/yellow **MUST** be used.
- **THE GN-503F AND GN-503FF PRODUCT WIRING HARNESS IS NOT INTERCHANGEABLE. THE GN-503F AND GN-503FF MUST USE PROPER WIRING HARNESS. PRODUCT WILL NOT FUNCTION IF INCORRECT HARNESS IS USED.**

**CAUTION:** Turn off electricity to prevent SHOCK and damage to smoke/CO alarm. Be sure the AC power to the smoke/CO alarm is not controlled by any on/off switch, or other type of switch, other than a fuse or circuit breaker.

**IMPORTANT:** Ensure that all fluorescent lighting fixtures are properly grounded.  
**NOTICE:** THE WIRING TO BE USED SHALL BE IN ACCORDANCE WITH THE PROVISIONS OF ARTICLE 210 OF THE NATIONAL ELECTRICAL CODE, NFPA 70. WIRE INSTALLATION SHOULD BE PERFORMED ONLY BY A LICENSED ELECTRICIAN.

## MOUNTING OUTLET BOX

Use a 2" x 3" switch box or a 4" square or octagon junction box. Mount a box for each smoke/CO alarm. If wall mounting is desired, be sure the box screws are oriented to upper right and lower left corners. Be sure to use supplied Mounting Plate.

## WIRING ONE ALARM

1. Run a minimum of 16 gauge, 2-conductor cable, plus ground (3 wires) to the junction box from a branch circuit. Smoke/CO alarms shall be connected to their own dedicated circuit. Use ANSI/UL Listed wire for Class 1 requirements.  
**NOTICE: THE WIRING TO BE USED SHALL BE IN ACCORDANCE WITH THE PROVISIONS OF ARTICLE 300.3(B) 210 OF THE NATIONAL ELECTRICAL CODE, NFPA 70.**
2. Make wire connections to the supplied wire harness as follows: black to black, white to white, and connect the ground wire to the metal outlet box.

FIGURE 12

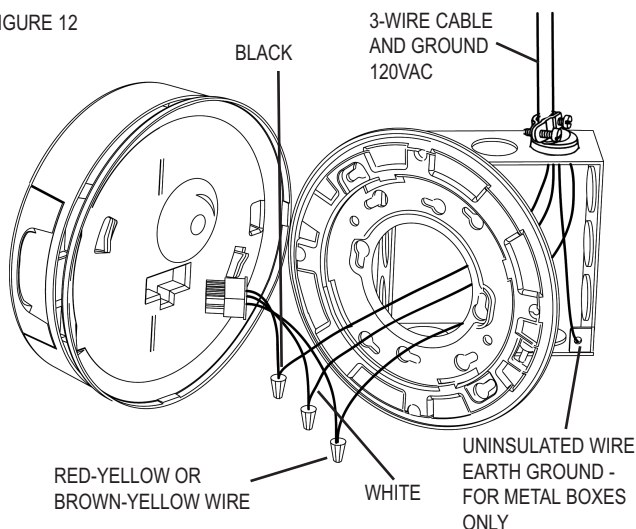

**NOTICE: RED-YELLOW WIRE AND BROWN-YELLOW WIRE: THE RED-YELLOW WIRE AND BROWN-YELLOW WIRE FROM THE SMOKE/CO ALARM IS FOR TANDEM CONNECTION ONLY. DO NOT USE, AND DO NOT REMOVE INSULATION CAP UNLESS CONNECTING ANOTHER CO ALARM, SMOKE/CO ALARM OR SMOKE ALARM.**

## GN-503 / GN-503F WIRING DIAGRAM

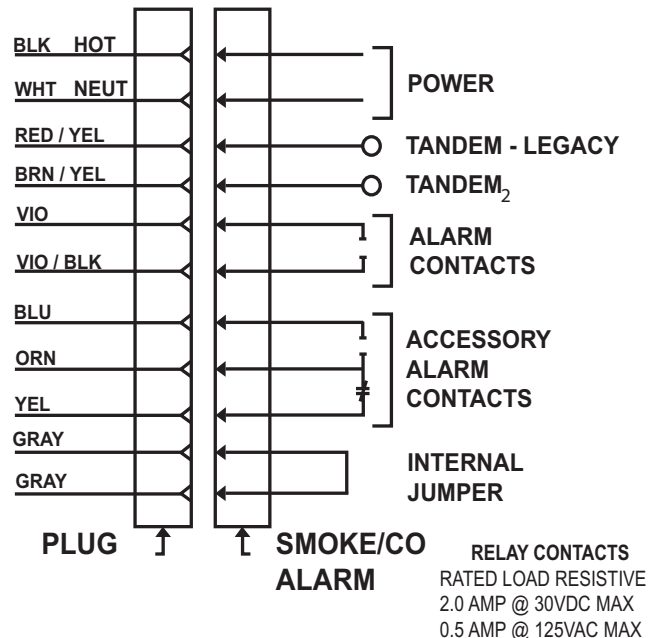

**CAUTION:** RED/YELLOW and BROWN/YELLOW wire to be capped when not in use. This wire is for tandem connection only. DO NOT connect to any other circuit.

## WIRING TWO OR MORE ALARMS

### Tandem Interconnect Installation

**NOTICE: ALL SMOKE/CO ALARMS TANDEM INTERCONNECTED MUST BE CONTROLLED BY THE SAME FUSE OR CIRCUIT BREAKER. OTHERWISE TANDEM FEATURE WILL NOT OPERATE. TANDEM INTERCONNECTION WILL OPERATE IN THE EVENT OF AC POWER FAILURE IF BATTERY IS CONNECTED TO THE SMOKE ALARM.**

**LIMITATIONS:** A maximum of 12 smoke/CO alarms (GN-503) may be connected together. Do not exceed 125 feet between each device. Do not exceed 1125 feet between first and last smoke/CO alarm.

**NOTICE: A MAXIMUM OF 12 SMOKE/CO ALARMS OF GN-503 WITH THE RELAY OPTION (F) MAY BE TANDEM INTERCONNECTED.**

Wire used for interconnection shall be in accordance with article 760 of the latest edition of National Electrical Code (NFPA 70) and must not exceed a resistance of 10 ohms.

## GN-503/GN-503F TANDEM INTERCONNECT WIRING DIAGRAM

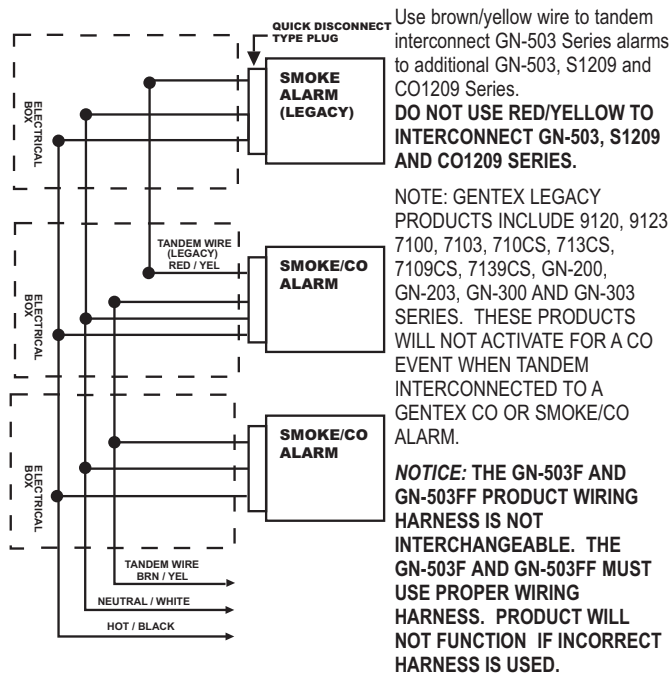



**LIMITATIONS:** Maximum of 12 smoke/CO alarms may be tandem interconnected together. Do not exceed 125 feet between each smoke/CO alarm. Do not exceed 1125 feet between the first and last smoke/CO alarm.

1. Run a minimum of 16 gauge, 3-conductor cable, plus ground (4 wires) to the first junction box from a dedicate branch circuit and between all smoke/CO alarms that are to be connected together. Use ANSI/UL Listed wire for Class 1 requirements. Power limited cable for multiple tandem connections are available at many commercial electrical retail stores.

**NOTICE:** WHEN USING BOTH TANDEM CONNECTIONS, 4-CONDUCTOR CABLE, PLUS GROUND (5 WIRES) MUST BE USED.

2. Make wire connections to the supplied wire harness as follows: black to black, white to white, 3rd conductor is used for tandem interconnect. The red/yellow wire or brown/yellow wire should be stripped to make the connection. Connect ground wire between metal outlet boxes.

FIGURE 13

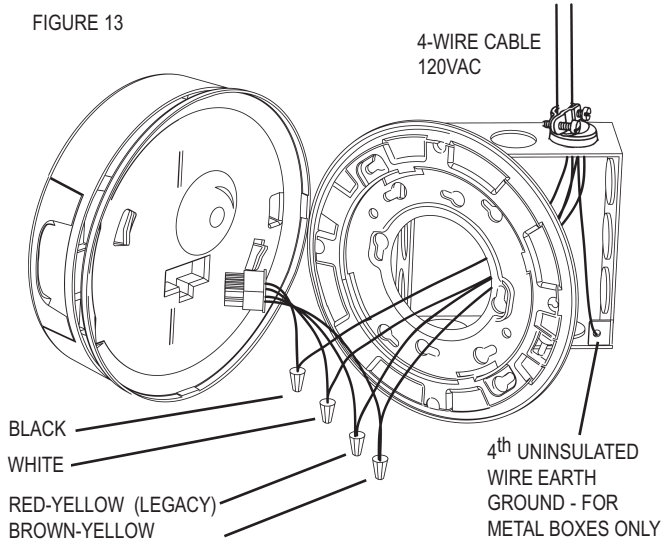

**NOTES ON TANDEM INTERCONNECTING MODELS**

- ♦ **DO NOT** connect Gentex alarms to other manufacturers' alarms.
- ♦ A maximum of 18 compatible smoke, heat, CO and/or combination smoke/CO alarms may be interconnected. No more than 12 of the 18 can be smoke alarms per NFPA72.
- ♦ No more than 12 Gentex model GN-503 Series may be connected in tandem.
- ♦ No more than 6 Gentex LEGACY products with Form A/Form C contacts may be connected in tandem.
- ♦ All units connected in tandem **MUST** get their power from the same dedicated branch circuit, all smoke alarms in tandem must be controlled by the same fuse or circuit breaker.
- ♦ After installation, to verify proper working conditions, all alarms must sound in this system. Test using the functional test button feature.
- ♦ When tandem interconnecting GN-503 Series to additional GN-503 Series, CO1209 or S1209 Series and the smoke alarms sound, but are not synchronized, and the CO alarm does not sound, the red/yellow wire has been used. Correct by using brown/yellow wire.
- ♦ Use red/yellow wire to tandem interconnect GN-503 alarms to Gentex legacy products. Legacy products include 9120/9123 Series, 7100/7103 Series, 710CS/713CS Series, 7109CS/7139CS Series, GN-200/GN-203 Series and GN-300/GN-303 Series. Legacy products will not activate for CO event.
- ♦ Use brown/yellow wire to tandem interconnect GN-503 Series alarms to additional GN-503 Series, S1209 Series and CO1209 Series.
- ♦ Do not tandem interconnect using both the red/yellow wire and brown/yellow wire between adjacent alarms. Only 1 tandem interconnect wire is needed between adjacent alarms.

**NOTICE:** IF A GN-503 SERIES OR CO1209 SERIES UNIT IS ANNUNCIATING FOR A CO EVENT, LEGACY PRODUCTS WILL NOT ACTIVATE AND WILL REMAIN SILENT.

**CAUTION:** Failure to observe any of the conditions set forth may cause system malfunction and damage to the device.

**NOTE: GENTEX LEGACY PRODUCTS INCLUDE 9120, 9123 7100, 7103, 710CS, 713CS, 7109CS, 7139CS, GN-200, GN-203, GN-300 AND GN-303 SERIES. THESE PRODUCTS WILL NOT ACTIVATE FOR A CO EVENT WHEN TANDEM INTERCONNECTED TO A GENTEX CO OR SMOKE/CO ALARM.**