

NUMBER	STUD SIZE	FURR. GAUGE	STUD SPACING	GYPSUM BOARD	TOTAL WALL THICKNESS \"T\"	SAB STC RATING	FIRE RATING	U.L. DESIGN NUMBER
0F1	-	7/8"	25	16"	5/8\"/>			

NUMBER	STUD SIZE	STUD GAUGE	STUD SPACING	GYPSUM BOARD	TOTAL WALL THICKNESS \"T\"	SAB STC RATING	FIRE RATING	U.L. DESIGN NUMBER
0D1	1.5/8"	25	16"	5/8\"/>				

NUMBER	STUD SIZE	FURR. GAUGE	BLOCK SIZE	STUD SPACING	GYPSUM BOARD	TOTAL WALL THICKNESS \"T\"	SAB STC RATING	FIRE RATING	U.L. DESIGN NUMBER
0CF	7/8"	8"	25	16"	5/8\"/>				

NUMBER	STUD SIZE	STUD GAUGE	STUD SPACING	GYPSUM BOARD	TOTAL WALL THICKNESS \"T\"	SAB STC RATING	FIRE RATING	U.L. DESIGN NUMBER
0B1	1.5/8"	25	16"	5/8\"/>				

NUMBER	STUD SIZE	STUD GAUGE	STUD SPACING	GYPSUM BOARD	TOTAL WALL THICKNESS \"T\"	SAB STC RATING	FIRE RATING	U.L. DESIGN NUMBER
0A1	1.5/8"	25	16"	5/8\"/>				

NUMBER	STUD SIZE	STUD GAUGE	STUD SPACING	GYPSUM BOARD	TOTAL WALL THICKNESS \"T\"	SAB STC RATING	FIRE RATING	U.L. DESIGN NUMBER
1D1	1.5/8"	25	16"	5/8\"/>				

NUMBER	STUD SIZE	BLOCK SIZE	STUD GAUGE	STUD SPACING	GYPSUM BOARD	TOTAL WALL THICKNESS \"T\"	SAB STC RATING	FIRE RATING	U.L. DESIGN NUMBER
1CX	7/8"	8"	25	16"	5/8\"/>				

NUMBER	STUD SIZE	STUD GAUGE	STUD SPACING	GYPSUM BOARD	TOTAL WALL THICKNESS \"T\"	SAB STC RATING	FIRE RATING	U.L. DESIGN NUMBER
1B1	1.5/8"	12"	25	16"	5/8\"/>			

NUMBER	STUD SIZE	STUD GAUGE	STUD SPACING	GYPSUM BOARD	TOTAL WALL THICKNESS \"T\"	SAB STC RATING	FIRE RATING	U.L. DESIGN NUMBER
1AX	3.5/8"	25	16"	5/8\"/>				

NUMBER	STUD SIZE	STUD GAUGE	STUD SPACING	GYPSUM BOARD	TOTAL WALL THICKNESS \"T\"	SAB STC RATING	FIRE RATING	U.L. DESIGN NUMBER
0G1	1.5/8"	25	16"	5/8\"/>				

NUMBER	STUD SIZE	STUD GAUGE	STUD SPACING	GYPSUM BOARD	TOTAL WALL THICKNESS \"T\"	SAB STC RATING	FIRE RATING	U.L. DESIGN NUMBER
2D	1"	25	24"	5/8\"/>				

NUMBER	STUD SIZE	BLOCK SIZE	STUD GAUGE	STUD SPACING	GYPSUM BOARD	TOTAL WALL THICKNESS \"T\"	SAB STC RATING	FIRE RATING	U.L. DESIGN NUMBER
2CX	7/8"	8"	25	16"	5/8\"/>				

NUMBER	STUD SIZE	STUD GAUGE	STUD SPACING	GYPSUM BOARD	TOTAL WALL THICKNESS \"T\"	SAB STC RATING	FIRE RATING	U.L. DESIGN NUMBER
2B2	2 1/2"	25	24"	5/8\"/>				

NUMBER	STUD SIZE	STUD GAUGE	STUD SPACING	GYPSUM BOARD	TOTAL WALL THICKNESS \"T\"	SAB STC RATING	FIRE RATING	U.L. DESIGN NUMBER
2A1	1.5/8"	25	16"	5/8\"/>				

NUMBER	STUD SIZE	STUD GAUGE	STUD SPACING	GYPSUM BOARD	TOTAL WALL THICKNESS \"T\"	SAB STC RATING	FIRE RATING	U.L. DESIGN NUMBER
1E1	1.5/8"	25	24"	5/8\"/>				

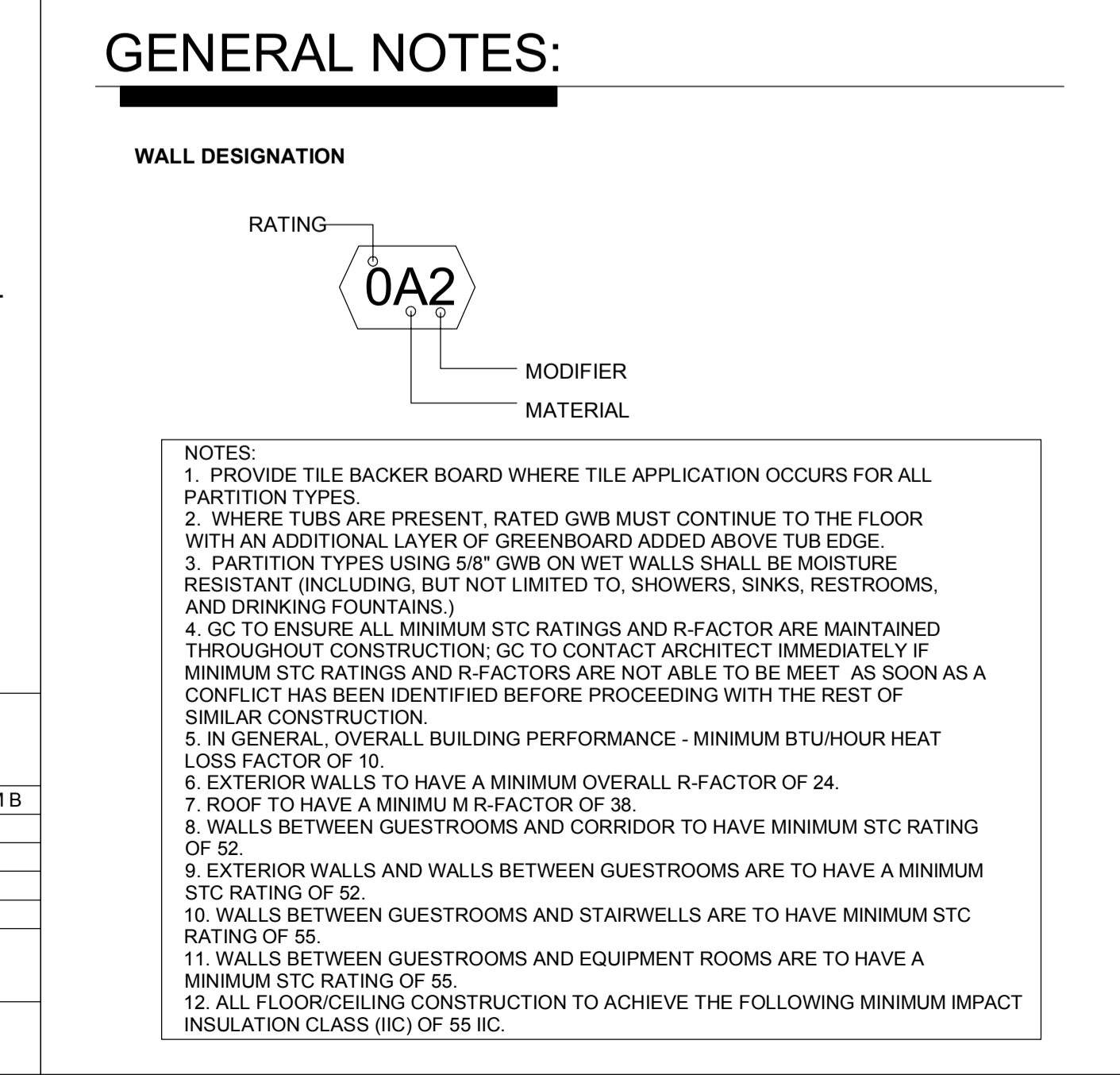
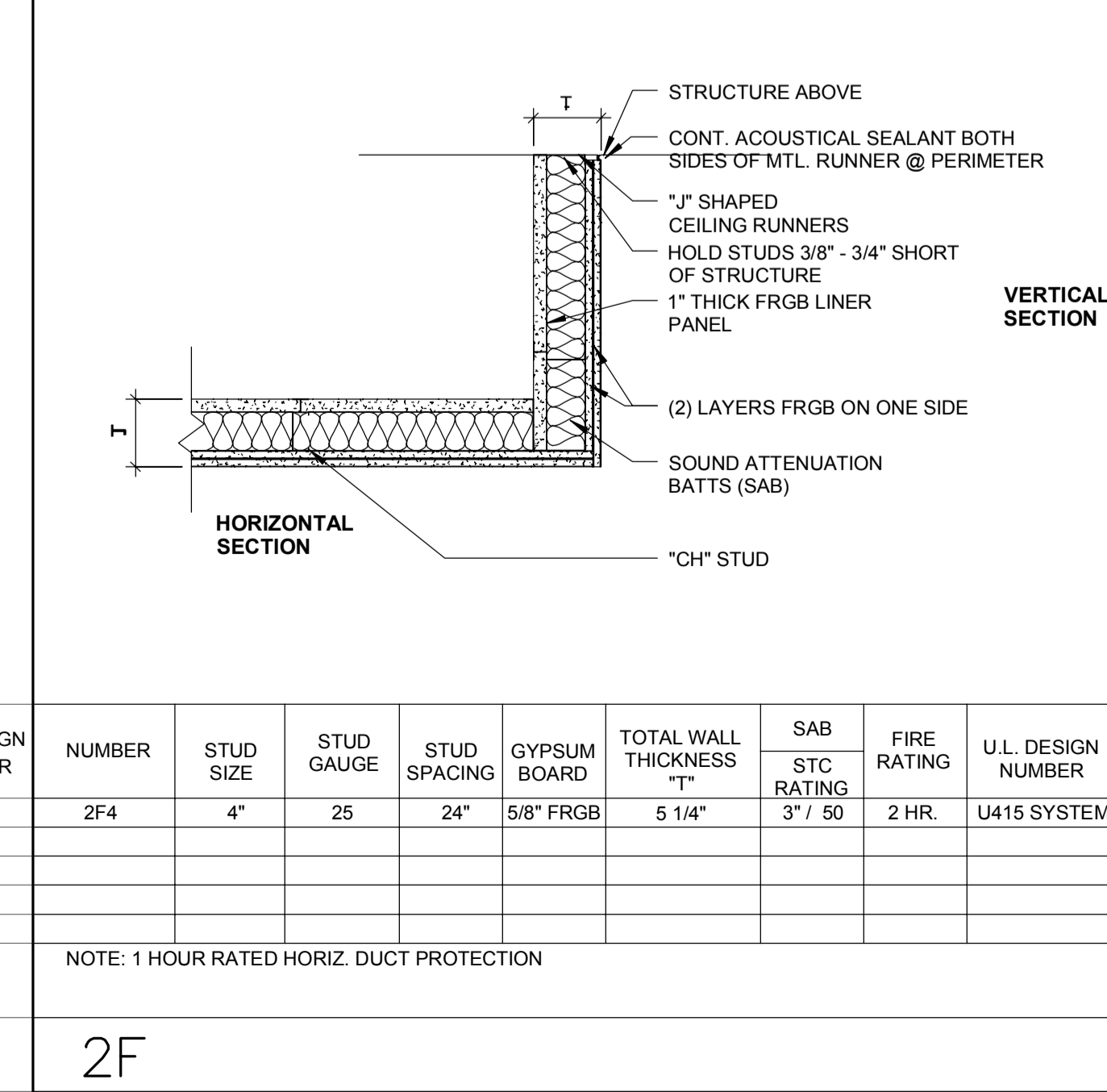
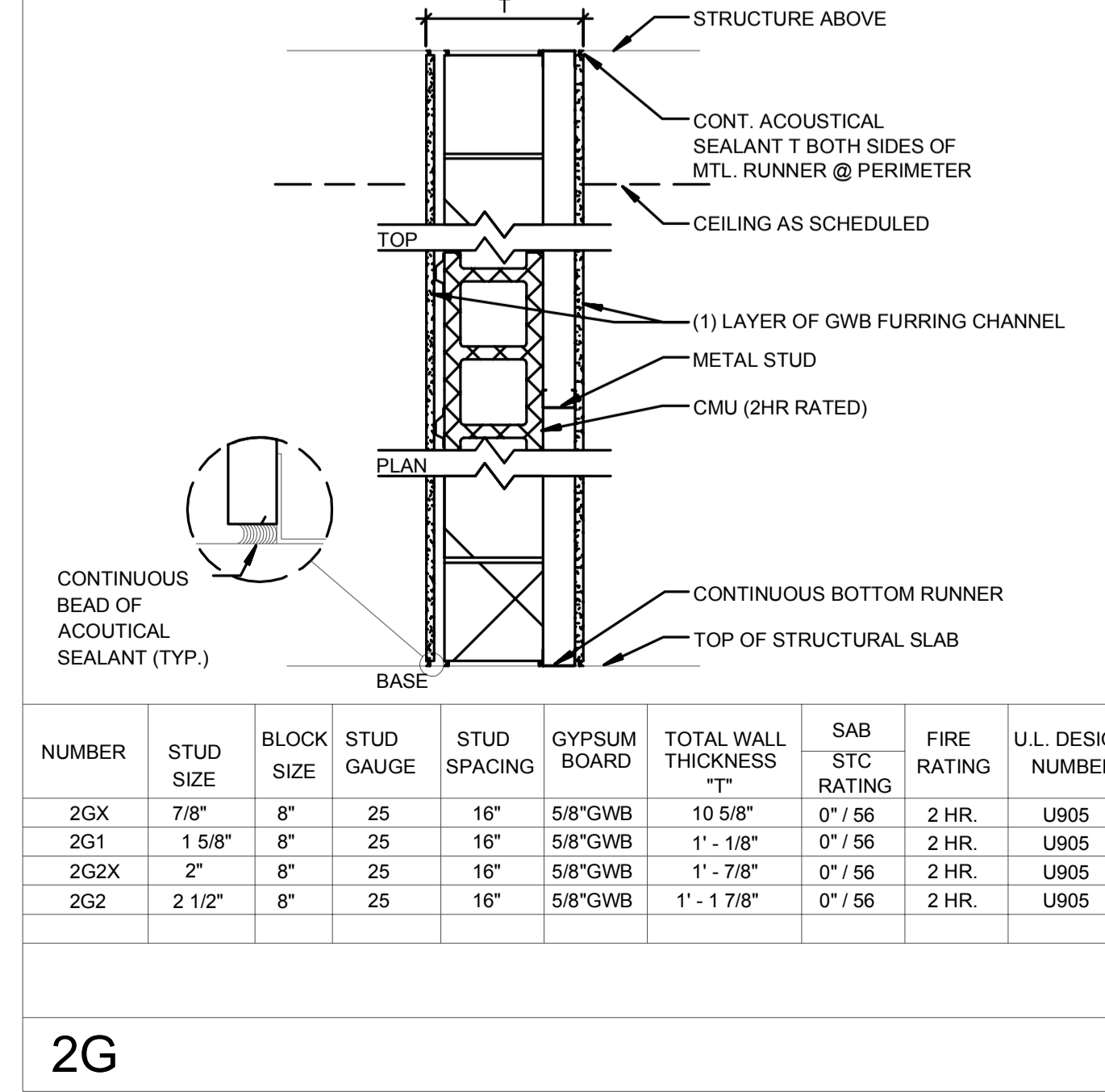

NUMBER	STUD SIZE	BLOCK SIZE	STUD GAUGE	STUD SPACING	GYPSUM BOARD	TOTAL WALL THICKNESS \"T\"	SAB STC RATING	FIRE RATING	U.L. DESIGN NUMBER
2GX	7/8"	8"	25	16"	5/8\"/>				

NUMBER	STUD SIZE	STUD GAUGE	STUD SPACING	GYPSUM BOARD	TOTAL WALL THICKNESS \"T\"	SAB STC RATING	FIRE RATING	U.L. DESIGN NUMBER
2F4	4"	25	24"	5/8\"/>				

NUMBER	STUD SIZE	STUD GAUGE	STUD SPACING	GYPSUM BOARD	TOTAL WALL THICKNESS \"T\"	SAB STC RATING	FIRE RATING	U.L. DESIGN NUMBER
2G2	2 1/2"	8"	25	16"	5/8\"/>			

NUMBER	STUD SIZE	STUD GAUGE	STUD SPACING	GYPSUM BOARD	TOTAL WALL THICKNESS \"T\"	SAB STC RATING	FIRE RATING	U.L. DESIGN NUMBER
2G2	2 1/2"	8"	25	16"	5/8\"/>			

NUMBER	STUD SIZE	STUD GAUGE	STUD SPACING	GYPSUM BOARD	TOTAL WALL THICKNESS \"T\"	SAB STC RATING	FIRE RATING	U.L. DESIGN NUMBER
2G2	2 1/2"	8"	25	16"	5/8\"/>			

Issue Dates:
 JULY 9, 2012
 ISSUE FOR PERMIT

WESTIN
 HOTELS & RESORTS

ROCKBRIDGE CAPITAL

NEWCASTLE HOTELS & RESORTS

CONTRACTOR
 IDC
 IDC CONSTRUCTION, LLC

NOTE: CONTRACTOR SHALL VERIFY ALL DIMENSIONS AND CONDITIONS OF THE ATTACHED DOCUMENTS AND ACTUAL FIELD CONDITIONS. THE CONTRACTOR SHALL BE RESPONSIBLE FOR VERIFYING ALL DIMENSIONS AND CONDITIONS OF THE ATTACHED DOCUMENTS AND ACTUAL FIELD CONDITIONS. THE CONTRACTOR SHALL BE RESPONSIBLE FOR VERIFYING ALL DIMENSIONS AND CONDITIONS OF THE ATTACHED DOCUMENTS AND ACTUAL FIELD CONDITIONS.

Project:
WESTIN EASTLAND PARK HOTEL RENOVATION
 FOR
ROCKBRIDGE CAPITAL, LLC.
 157 HIGH STREET
 PORTLAND, ME

This Document is the property of RainTree Architecture, Inc. (PFS) and is to be used only in connection with the project named herein. Reproduction in whole or in part, shall be allowed only with the express written or verbal permission from the architect. Drawing scales as shown are valid on the original sized document which is 30 by 42 inches. © 2013 RainTree Architecture, Inc. All Rights Reserved.

Sheet Title:
PARTITION TYPES

Job Number: 11009
 Scale: AS NOTED
 Drawn: ARR
 Checked: BAS
 Date: Nov. 21, 2011

PERMIT SET - RELEASED FOR CONSTRUCTION

A-601