

Project: Gateway PG - High St Façade Repairs Phase 1
Project #: WO 3521
Date/Time: September 21, 2015, 10:15 a.m.
Observers Adam Sampson, Author (BSE), Josh Martin-McNaughton (BSE)

I visited the site to review the progress of the work and to check for general conformance with the design intent of the drawings and specifications for this project. The weather at the time of this visit was sunny and 65 degrees F.

The following observations were made:

1. KISC has removed all of the CMU and brick masonry façade at the 4th level. All steel beams on the 4th level have been cleaned, primed and painted, see photo below.



2. Generally, the existing steel is in fair to good condition with the exception of one beam end. Dan, the onsite foreman pointed out an existing W12 on the 4th level near column line 1 that has experienced section loss on its bottom flange, see photos below. BSE will provide a sketch for Smith Custom Fabrication (SCF) to weld a plate to the bottom of the flange, see attached sketch.



3. SCF has begun to install column extensions at the 4th level. The majority of the column extensions have been tack welded in place and will be fully welded later. Existing steel columns will need to be cleaned, primed and painted before concrete repairs around the columns are completed, see photos below.



4. Bolt holes for the column extension at column line 4 are located 1 3/4" higher than what was intended. BSE is providing SCF with a sketch to alter this connection.
5. CMU and brick demolition debris are stored on the 1st level. The debris should be removed from the site at a minimum weekly basis. A pile of fasteners was observed on the 4th level and should be disposed of to prevent them from being kicked into the drive lane. See photos below.



6. At Column line 1, the exposed CMU, is reinforced but un-grouted providing no lateral resistance to the wall, see photo below. This is representative of what we have found along the High Street façade as well.
7. KISC has continued to prepare asphalt potholes and other tripping hazards at the 3rd level. KISC has begun to set up shoring and staging for work at the 3rd level, see photo below.



CC: File, City of Portland Inspections Office, CJ Follini (Noyack), Michael Urbanski (Noyack), Bob Bold (SSPlus), Tim Rich (KISC), Todd Neal (BSE), Joshua Martin-McNaughton (BSE)

Attached File: Sketch to Repair Existing W12 Beam Flange

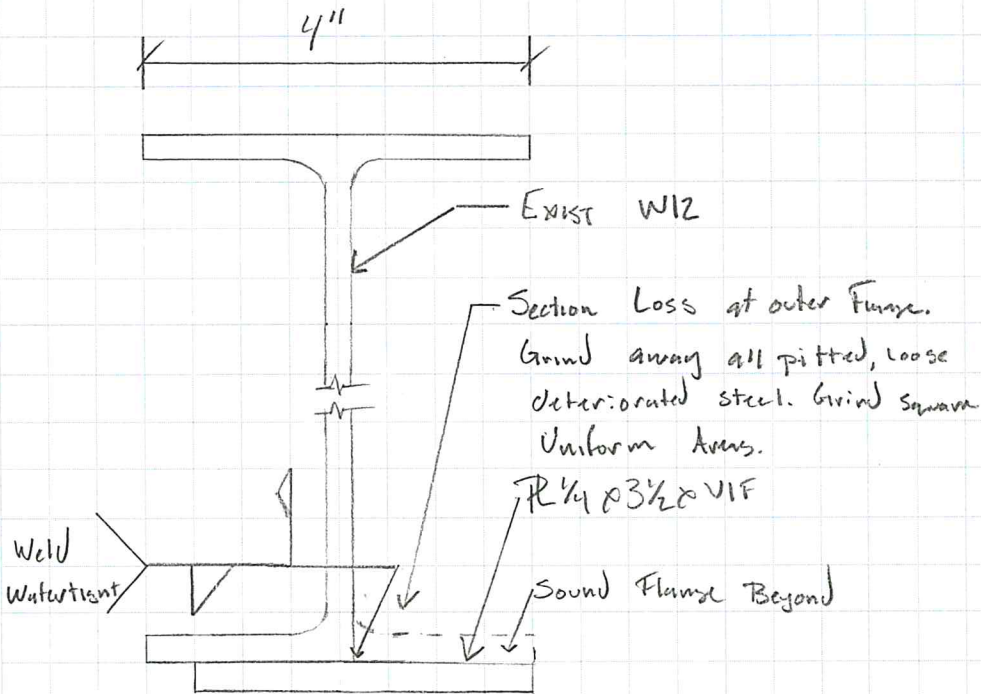

EXIST W12 Section View

Note:- Conc Curb, PC Deck + Topping slab not shown for clarity.
- Field Prime and Paint steel after completion of welding.

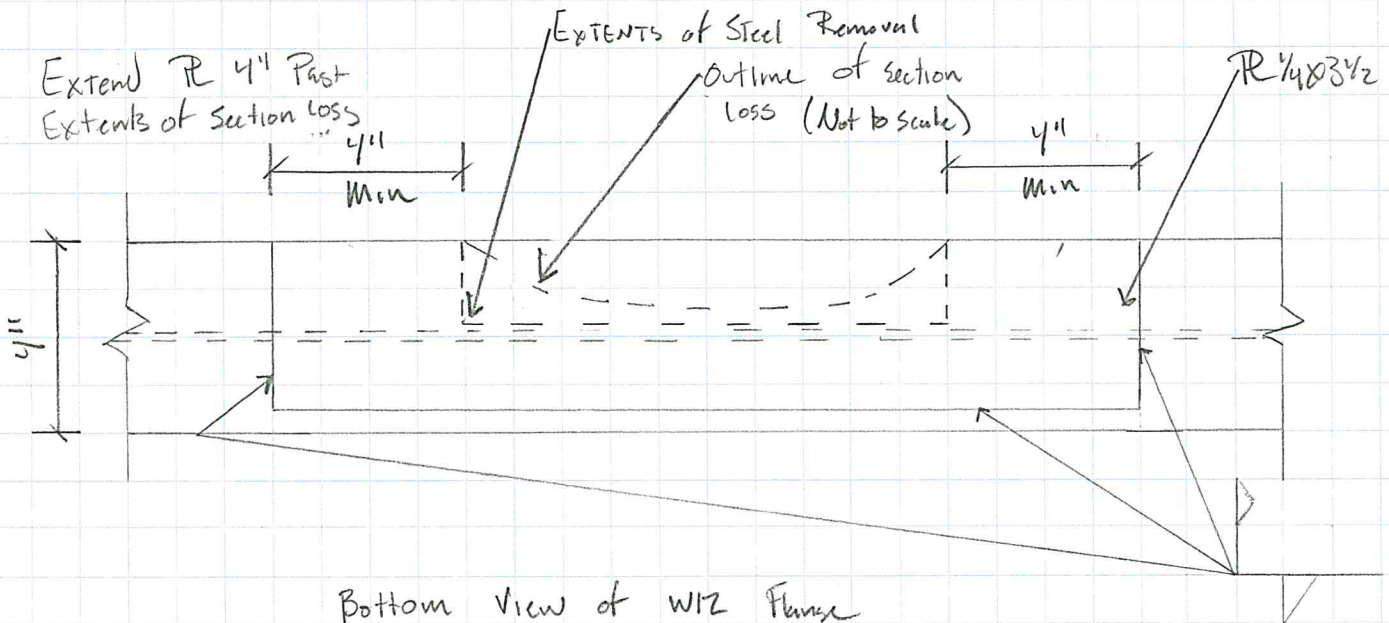

Bottom View of W12 Flange