

Stageline Mobile Stage Inc.
700 Marsolais Street
L'Assomption Quebec
J5W 2G9 Canada
Attn: Félix Boulianne

RE: SL75 US Certification 2018
CRE Project No. 17.501.85

To Whom It May Concern,

Clark Reder Engineering Inc. (CRE) has completed our review of the documentation provided to us regarding the Stageline SL75 Mobile Stage Unit. The mobile unit was manufactured by Stageline Mobile Stage Inc. of Quebec, Canada.

Attached please find the following documentation which outlines the usage requirements and wind management plan for this mobile stage unit:

- Certification 2018: Wind Resistance and Procedures in case of Heavy Winds
- SL75 User's Manual, Stageline 2018
- SL75 Technical Drawings, 2018

CRE has determined that the SL75 Mobile Stage Units, when built and used in accordance with the manufacturers guidelines, represents a safe design in accordance with the structural provisions of the 2015 International Building Code and is fit for use in all 50 states. This stamped document is valid for use through January 31, 2019.

The stage must have been inspected within the last 24 months by a competent authority for this certificate to be valid. If critical defects were found on the structure during the inspection, repairs and procedures must have been approved by a structural engineer and completed with professional standards. Inspection, engineering approval (if applicable) and repair documents must remain available for presentation upon request.

As stated in the SL75 User's Manual, the stage system must be operated under the supervision of Stageline trained and certified personnel.

We trust this information is suitable for your needs at this time. If you have any questions, please do not hesitate to contact our office.

Regards,

Clark-Reder Engineering Inc.

Jeffrey M. Reder, P.
OH Registration No. 67450



1/22/2018



Project Name: SL75 US
CRE Project No: 17.501.86

December 24, 2017
Page 2



Clark Reder Engineering, Inc.
Illinois Professional Engineer design firm registered in Illinois
#104,066

CERTIFICATE VALID FOR:
Odds Are Productions - unit 940
DATE OF ISSUE: April 16th, 2018
EXPIRY DATE: January 31st, 2019



Project Name: SL75 US
CRE Project No: 17.501.86

December 24, 2017
Page 3

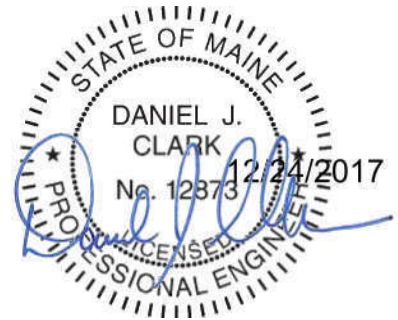
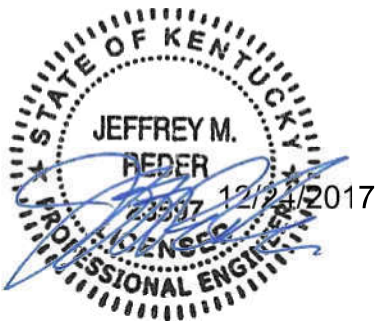

Professional Certification. I hereby certify that these documents were prepared or approved by me, and that I am a duly licensed professional engineer under the laws of the State of Maryland, License No. 38421, Expiration Date: 01/29/2018

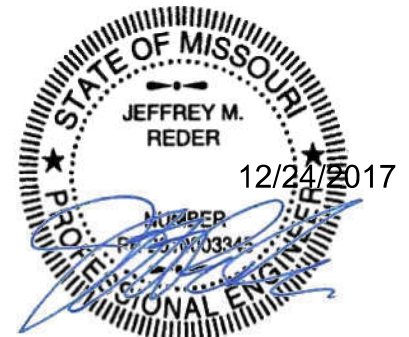

CERTIFICATE VALID FOR:

Odds Are Productions - unit 940

DATE OF ISSUE: *April 16th, 2018*

EXPIRY DATE: *January 31st, 2019*



Project Name: SL75 US
CRE Project No: 17.501.86

December 24, 2017
Page 4

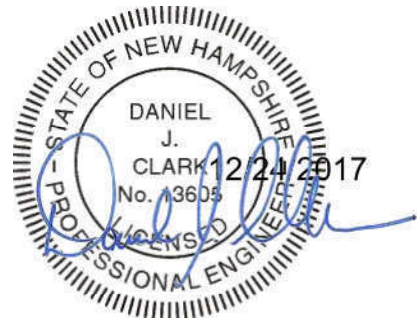

JEFFREY M. REDER
12/24/2017

CERTIFICATE VALID FOR:

No. 9610 Odds Are Productions - unit 940

DATE OF ISSUE: April 16th, 2018

EXPIRY DATE: January 31st, 2019

REGISTERED PROFESSIONAL ENGINEER
CIVIL

STAGELINE

Project Name: SL75 US
CRE Project No: 17.501.86

December 24, 2017
Page 5



Clark Reder Engineering
F-12154

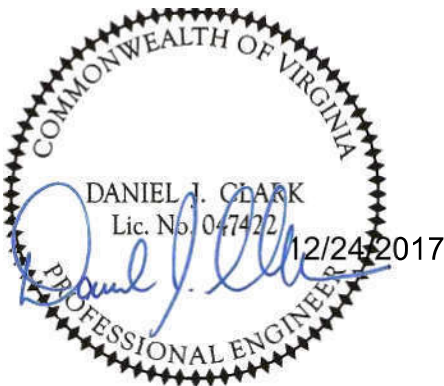

CERTIFICATE VALID FOR:
Odds Are Productions - unit 940
DATE OF ISSUE: *April 16th, 2018*
EXPIRY DATE: *January 31st, 2019*

Jr



Certification 2018

Stageline Mobile Stage Equipment

Wind Resistance and Procedures in case of Heavy Winds

Expiration date: January 31st, 2019

CERTIFICATE VALID FOR:

Odda Are Productions - unit 940
DATE OF ISSUE: *April 16th, 2018*

EXPIRY DATE: *January 31st, 2019*



Stageline Mobile Stage Inc. certifies that the components identified below have been specified by the engineering department to meet the following wind resistance and also the NFPA 701-04 and ULC S-109 regulations (Standard Methods of Fire Tests for Flame Propagation of Textiles and Films).

MODEL	WIND Resistance 3S ¹	WIND Resistance (without windwalls) 3S ¹	WINDWALL AREA
SL50 *	77 mph (123 km/h)	102 mph (165 km/h)	200ft ² (18.6m ²) + 2 x 86ft ² (8.0m ²)
SL75	77 mph (123 km/h)	115 mph (185 km/h)	200ft ² (18.6m ²) + 2 x 86ft ² (8.0m ²)
SL100	77 mph (123 km/h)	102 mph (165 km/h)	348ft ² (32.4m ²) + 2 x 147ft ² (13.7m ²)
SL100MIX	77 mph (123 km/h)	102 mph (165 km/h)	348ft ² (32.4m ²) + 2 x 147ft ² (13.7m ²)
SL200	77 mph (123 km/h)	115 mph (185 km/h)	490ft ² (45.5m ²) + 2 x 198ft ² (18.4m ²)
SL250 CLASSIC	77 mph (123 km/h)	115 mph (185 km/h)	528ft ² (49.1m ²) + 2 x 153ft ² (14.2m ²)
SL250NG	77 mph (123 km/h)	115 mph (185 km/h)	566ft ² (52.6m ²) + 2 x 243ft ² (22.6m ²)
SL260	77 mph (123 km/h)	115 mph (185 km/h)	599ft ² (55.6m ²) + 2 x 257ft ² (23.9m ²)
SL320	77 mph (123 km/h)	115 mph (185 km/h)	991ft ² (92.1m ²) + 2 x 600ft ² (55.7m ²)
PROMOBILE	77 mph (123 km/h)	115 mph (185 km/h)	594ft ² (55.2m ²) + 2 x 288ft ² (26.8m ²)
SAM440	77 mph (123 km/h)	115 mph (185 km/h)	1147ft ² (106.6m ²) + 2 x 731ft ² (67.9m ²)
SAM550	77 mph (123 km/h)	115 mph (185 km/h)	2 x 690ft ² (64.1m ²) + 2 x 747ft ² (69.4m ²)
SAM555	77 mph (123 km/h)	115 mph (185 km/h)	2 x 805ft ² (74.8m ²) + 2 x 793ft ² (73.7m ²)
SAM575	77 mph (123 km/h)	115 mph (185 km/h)	2 x 805ft ² (74.8m ²) + 2 x 793ft ² (73.7m ²)
SL250/260 Covered Wings	64 mph (103 km/h)	115 mph (185 km/h)	632ft ² (58.7m ²) + 2 x 112ft ² (10.4m ²) per side
SAM555 Covered Wings	64 mph (103 km/h)	115 mph (185 km/h)	2100ft ² (195.1m ²) + 275ft ² (25.5m ²) per side
SAM575 Covered Wings	64 mph (103 km/h)	115 mph (185 km/h)	2100ft ² (195.1m ²) + 275ft ² (25.5m ²) per side
SAM750 (incl. Covered Wings)	77 mph (123 km/h)	115 mph (185 km/h)	2 x 2075ft ² (192.8m ²) + 4 x 430ft ² (39.9m ²) + 2 x 3177ft ² (295.2m ²)
HY Tower	77 mph (123 km/h)	115 mph (185 km/h)	Screen area : 144 ft ² (13.4m ²) without ballast, 384ft ² (35.7m ²) with appropriate ballast
FOH2424	77 mph (123 km/h) ²	115 mph (185 km/h) ²	250ft ² (23.3m ²) + 175ft ² (16.3m ²) + 2 x 261ft ² (24.3m ²) + 613ft ² (56.9m ²)
FOH3224	77 mph (123 km/h) ²	115 mph (185 km/h) ²	261ft ² (24.2m ²) + 165ft ² (15.3m ²) + 2 x 362ft ² (33.6m ²) + 813ft ² (75.5m ²)

This equipment must have been inspected within the last 24 months by a competent authority for this certificate to be valid. If critical defects were found on the structure during the inspection, repairs and procedures must have been approved by a structural engineer and completed in accordance with professional standards. Inspection, engineering approval (if applicable) and repair documents must remain available for presentation upon request.

Research & Engineering

* Unit #536 and up
¹ 3 seconds wind gust
² Ballast weights are required, see Technical Drawings for details



Procedures in case of Heavy Winds

Expiration date: January 31st 2019

CERTIFICATE VALID FOR:

Odds Are Productions - unit 940

DATE OF ISSUE: April 16th, 2018

EXPIRY DATE: January 31st, 2019



Windy weather conditions:

A) During setup and dismantling of the stage and windwalls

The windwalls are the elements most at risk in windy conditions and the installation can become problematic. Wait until the wind has subsided before installing windwalls. If this is not possible, roll up windwalls and fasten with ratchet straps to the roof before raising the structure so it does not lash out and hurt anyone. We also suggest increasing your staff to have this operation completed more rapidly and safely.

If wind speeds exceed 40 mph (64 km/h), windwalls and stage installation are not recommended. We strongly suggest you wait until the wind has diminished before completing the setup or dismantling the stage and windwalls.

B) Prior to the start of the event

The Stageline mobile stages are designed to resist 3 seconds wind gusts up to 115 mph¹ (185 km/h). However, this wind resistance depends on a proper installation of the stage and its equipment (refer to User's Manual for details). In any weather condition, the stage must be inspected by a certified technician and all its components must be secured.

1. If wind gusts are expected to exceed **50 mph (80 km/h)** (40 mph if covered wings are installed):
 - a) Roof structure should be lowered to reduce exposed surface.
 - b) Windwalls should be removed. If not possible, roll up all access doors.
 - c) Remove, lower and secure all movable parts i.e. speakers, screens, lighting equipment or banners to limit any movement.

C) During the event

1. If wind gusts exceed **40 mph (64 km/h)** (30 mph if covered wings are installed):
 - a) Roll up all access doors.
 - b) Remove, lower and secure all movable parts i.e. speakers, screens or lighting equipment, banners, to limit any movement.
2. If wind gusts exceed **50 mph (80 km/h)** (40 mph if covered wings are installed):
 - a) Unclasp the windwalls or slash openings in the windwalls.
 - b) The public and all non-essential personnel must remain at least 100 ft (30 m) away from the stage.
3. If wind gusts exceed **60 mph (97 km/h)** (50 mph if covered wings are installed):
 - a) All remaining personnel must remain at least 100 ft (30 m) away from the stage.

Note: The most probable scenario during a violent storm is that the windwalls will be torn away. This is why it is so important to keep all technicians and the crowd at a safe distance.

Professional Engineering stamps and licenses for Jonathan Doucet, dated 3/01/18:

- PROFESSIONAL ENGINEER OF PROVINCE OF BRITISH COLUMBIA (#35739)
- REGISTERED PROFESSIONAL ENGINEER OF PROVINCE OF MANITOBA (Member 38113)
- LICENSED PROFESSIONAL ENGINEER OF PROVINCE OF ONTARIO (#1770279)
- REGISTERED PROFESSIONAL ENGINEER OF PROVINCE OF NOVA SCOTIA (10417)
- REGISTERED PROFESSIONAL ENGINEER OF NEWFOUNDLAND AND LABRADOR (JONATHAN DOUCET, SIGNATURE, DATE 3/01/18)
- INGÉNIEUR - ENGINEER OF QUÉBEC (127760)
- PROFESSIONAL ENGINEER OF SASKATCHEWAN (MEMBER 18013)
- PROFESSIONAL ENGINEER OF ALBERTA (JONATHAN DOUCET)
- LICENSED PROFESSIONAL ENGINEER PROVINCE OF NEW BRUNSWICK (L5000, 2018, J.A. Jonathan Doucet, SIGNATURE, DATE 3/01/18)
- INGÉNIEUR TITULAIRE DE PERMIS PROVINCE DU NOUVEAU-BRUNSWICK
- THE ASSOCIATION OF PROFESSIONAL ENGINEERS OF THE PROVINCE OF PRINCE EDWARD ISLAND (VALID FOR THE YEAR 2018, Jonathan Doucet, No. 1554, DATE: 8/01/18)
- LICENSED PROFESSIONAL ENGINEER PROVINCE OF PRINCE EDWARD ISLAND

Research & Engineering

*Unit #536 and up

¹102 mph (165 km/h) for an SL50*, SL100 or SL100 Mix Position; for FOH structures, ballast weights are required, see Technical Drawings for details



Expiration date: January 31st 2019

CERTIFICATE VALID FOR:

Odds Are Productions - unit 940

DATE OF ISSUE: *April 16th, 2018*

EXPIRY DATE: *January 31st, 2019*



Certification 2018 Stageline Mobile Stage Equipment SL75

Stageline Mobile Stage Inc. certifies that the aforementioned equipment was designed under the supervision of professional engineers, members of a professional association.

The considered loads are as follows:

Floor	Permanent Load	Self Weight
	Live Load	150 psf (7.2 kN/m ²)
Roof	Permanent Load	Self Weight
	Live Load	20 psf (0.96 kN/m ²)
	Point Loads	4250 lbs (1930 kg) see Rigging Plan
Wind	Gust Speed	77 mph (123 km/h) with windwalls
	Gust Speed	115 mph (185 km/h) without windwalls
	Lateral Pressure	9.1 psf & 16.1 psf (0.4 kN/m ² & 0.8 kN/m ²)
	Uplift Pressure	4.9 psf & 8.6 psf (0.2 kN/m ² & 0.4 kN/m ²)

When built in accordance with the structural plans, this equipment is considered safe and can be used to the end for which it has been designed as long as it is operated in accordance with the directives included in the User's Manual. The stage must have been inspected within the last 24 months by a competent authority for this certificate to be valid. If critical defects were found on the structure during the inspection, repairs and procedures must have been approved by a structural engineer and completed in accordance with professional standards. Inspection, engineering approval (if applicable) and repair documents must remain available for presentation upon request.

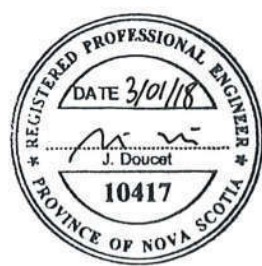
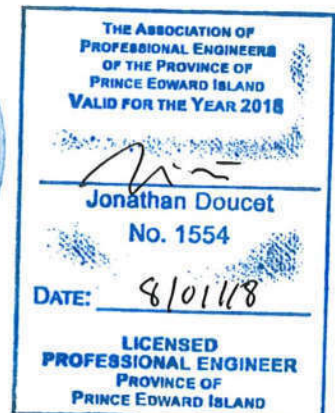
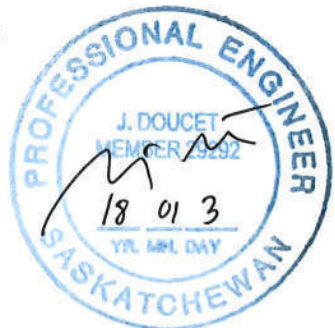

3/01/18
Research & Engineering



96, rue Blanchard, local E-2, Ste-Thérèse, QC, J7E 4R9

November 1st, 2012

Mr. Marius Chouinard
Technical Director
Stageline Mobile Stage
700 Marsolais,
L'Assomption (Québec) J5W 2G9

**SUBJECT : Certification of material used for construction of
vinyl windwalls and skirt**

Dear Mr. Chouinard,

As the manufacturer of vinyl windwalls and skirts for our client Stageline Mobile Stage, we hereby attest that all vinyl used in the production of these elements is flame-retardant and in conformity with the prerequisites of norm NFPA 701.

You will find herewith the precise characteristics of the vinyl used in the production of these windwalls and skirts.

On each of the items produced for our client, we have also placed a patch mentioning the respect of norm NFPA 701. This patch includes a space, to be filled out by Stageline Mobile Stage, indicating the total surface area of each element.

Please accept this letter as written confirmation showing the non-combustible characteristics of the vinyl used by Stageline Mobile Stage.

Please do not hesitate to contact us if you have any questions.

Best regards,

A handwritten signature in blue ink, consisting of several vertical lines followed by a large, stylized loop.

Sylvain Des Alliers, president
Canevas Design



Exova
2396 Speckman Dr
Mississauga
Ontario
Canada
L5R 1K3

T: +1 (905) 822-4111
F: +1 (905) 823-1446
E: sales@exova.com
W: www.exova.com



Testing. Advising. Assuring.

ELECTRONIC DRAFT COPY

**NFPA 701-2010 Test Method 1 - Flame
Propagation of "Naizil ZF-18 #J03 Orange"**

A Report To: **Naizil Inc.**
12667 Coleraine Drive
Bolton, ON
L7E 5T2

Phone: (905) 857-6633
Email: engineering@naizilcanada.com

Attention: Frank Petizian

Submitted By: Exova Warringtonfire North America

Report No. 10-002-491(B)
3 pages + appendix

Date: July 11, 2012

ACCREDITATION To ISO/IEC 17025 for a defined Scope of Testing by the International Accreditation Service

SPECIFICATIONS OF ORDER

Determine flame propagation in accordance with Test Method 1 of NFPA 701, 2010 Edition, as per Exova Warringtonfire North America Quotation No. 12-002-06458 accepted July 9, 2012.

IDENTIFICATION

Fabric identified as: "Naizil ZF-18 #J03 Orange".
 (Exova sample identification number 12-002-S0491-1)

TEST RESULTS

NFPA 701 - 2010 Test Method 1
 Standard Methods of Fire Tests for
Flame Propagation of Textiles and Films

Tested "as-received"

	<u>Initial Mass (g)</u>	<u>Final Mass (g)</u>	<u>Mass Loss (%)</u>	<u>Afterflame Time (s)</u>	<u>Flaming Dripping (s)</u>
1:	38.0	36.8	3.3	0.0	0.0
2:	39.5	38.4	2.9	0.0	0.0
3:	39.7	38.9	2.0	0.0	0.0
4:	40.1	38.9	2.9	0.0	0.0
5:	40.3	39.1	2.9	0.0	0.0
6:	40.0	39.0	2.4	0.0	0.0
7:	40.5	39.6	2.2	0.0	0.0
8:	39.6	38.9	1.8	0.0	0.0
9:	39.1	38.3	2.1	0.0	0.0
10:	40.4	39.4	<u>2.3</u>	0.0	<u>0.0</u>

Mean: 2.5 0.0

Standard Deviation: 0.5

Maxima Specified by
 NFPA 701 Test Method 1: 40.0 2.0



EXOVA

CONCLUSIONS

When tested "as-received", the fabric identified in this report meets the requirements of Test Method 1 of NFPA 701, 2010 Edition.

Note: This is an electronic copy of the report. Signatures are on file with the original report.

Victor Tarcenco,
Fire Testing

Ian Smith,
Fire Testing

Note: This report and service are covered under Exova Canada Inc. Standard Terms and Conditions of Contract which may be found on the Exova website (www.exova.com), or by calling 1-866-263-9268.



NFPA 701-2010 Test Method 1 - Flame Propagation of "Naizil ZF-18 #J03 Orange"

For: Naizil Inc.

Report No. 10-002-491(B)

EXOVCI

APPENDIX

(1 page)

Summary of Test Procedure

NFPA 701 - 2010 Edition
Standard Methods of Fire Tests for
Flame Propagation of Textiles and Films

Test Method 1

Ten specimens are cut, each 150 mm x 400 mm, with the length parallel to the lengthwise direction of the material. After having been weighed, the specimens are conditioned for at least 30 minutes at $105 \pm 3^{\circ}\text{C}$ ($220 \pm 5^{\circ}\text{F}$). Specimens may also be conditioned at $20 \pm 5^{\circ}\text{C}$ for a minimum of 24 hrs., if they melt or permanently deform at 105°C .

Each specimen is removed from the conditioning chamber individually and attached to a pin bar which is then mounted on a support hanger at the back ceiling of a specified test chamber. A specified gas flame is applied to the centre of the lower edge of the specimen for 45 seconds and then withdrawn. The specimen is allowed to burn until the flame self-extinguishes, after which it is removed from the pin bar and re-weighed. The percent mass loss is determined and used as a measure of total flame spread and specimen damage.

Flame Propagation Performance Criteria:

Where fragments or residues of specimens that fall to the floor of the test chamber continue to burn for more than an average of 2 seconds per specimen, the material shall be recorded as failing the test.

Where the average mass loss of the 10 specimens in a sample is greater than 40 percent, the material shall be recorded as failing the test.

Where the percent mass loss of any individual specimen exceeds the mean value plus three standard deviations, a second set shall be tested.

Where the percent mass loss of any individual specimen in the second set of specimens exceeds the mean value of the second set plus three standard deviations calculated for the second set, the material shall be recorded as failing the test.

Exova
2396 Spackman Dr
Mississauga
Ontario
Canada
L5K 1S3

T: +1 (905) 822-4111
F: +1 (905) 822-1446
E: sales@exova.com
W: www.exova.com



Testing. Advising. Assuring.

ELECTRONIC DRAFT COPY

**NFPA 701-2010 Test Method 2 - Flame
Propagation of "Naizil ZF-18 #J03 Orange"**

A Report To: **Naizil Inc.**
12667 Coleraine Drive
Bolton, ON
L7E 5T2

Phone: (905) 857-6633
Email: engineering@naizilcanada.com

Attention: Frank Petizian

Submitted By: Exova Warringtonfire North America

Report No. 12-002-491(C)
2 pages + appendix

Date: July 11, 2012

ACCREDITATION To ISO/IEC 17025 for a defined Scope of Testing by the International Accreditation Service

SPECIFICATIONS OF ORDER

Determine flame resistance in accordance with Test Method 2 of NFPA 701, 2010 Edition, as per Exova Warringtonfire North America Quotation No. 12-002-06458 accepted July 9, 2012.

IDENTIFICATION (Exova sample identification number 12-002-S0491-1)

Material identified as "Naizil ZF-18 #J03 Orange".

TEST RESULTS

NFPA 701 - 2010 Test Method 2
 Standard Methods of Fire Tests for
Flame Propagation of Textiles and Films

Tested "as-received" and in flat sheet configuration.

Weight: 661.4 g/m ²	<u>Length of Char (mm)</u>	<u>Afterflame Time (s)</u>	<u>Flaming Dripping Time (s)</u>	
Trial 1:	375	0.0	0.0	
2:	273	0.0	0.0	
3:	384	0.0	0.0	
4:	362	0.0	0.0	
5:	291	0.0	0.0	
6:	390	0.0	0.0	
7:	376	0.0	0.0	
8:	282	0.0	1.0	
9:	297	0.0	0.0	
10:	338	0.0	0.0	
Maxima Specified by NFPA 701 Test Method 2:	435	2.0	2.0	(individual)

CONCLUSIONS

When tested "as-received" and in flat sheet configuration, the material identified in this report meets the flame propagation requirements of Test Method 2 of NFPA 701, 2010 Edition.

Note: This is an electronic copy of the report. Signatures are on file with the original report.

Victor Tarcenco,
Fire Testing.

Ian Smith,
Fire Testing.

Note: This report and service are covered under Exova Canada Inc. Standard Terms and Conditions of Contract which may be found on the Exova website (www.exova.com), or by calling 1-866-263-9268.



NFPA 701-2010 Test Method 2 - Flame Propagation of "Naizil ZF-18 #J03 Orange"

For: Naizil Inc.

Report No. 12-002-491(C)

EXOVd

APPENDIX

(1 page)

Summary of Test Procedure

NFPA 701 - 2010 Edition
Standard Methods of Fire Tests for
Flame Propagation of Textiles and Films

Test Method 2

For conducting flame tests of fabrics in the flat configuration, Test Method 2 of NFPA 701 specifies testing on at least ten specimens, each 125 x 1200 mm (5 x 47 inches).

For conducting flame tests of fabrics hung in folds, at least four specimens, each 610 x 1200 mm (24 x 47 inches) are required. Each specimen is folded longitudinally to form four folds. Those specimens that cannot be folded are tested in the flat configuration.

Prior to testing, the specimens are conditioned at 105°C (220°F) for a period of 1 to 3 hours.

Each specimen is removed from the conditioning chamber individually, and immediately suspended in a steel stack, 305 mm (12 inches) square and 2133 mm (84 inches) high. The stack is open at both the top and bottom and is supported 305 mm above the floor. The lower edge of the specimen is positioned 100 mm (4 inches) above the tip of a gas burner which is inclined at 25° to the vertical. The burner is adjusted to yield a flame 280 mm (11 inches) in height and is positioned directly beneath the specimen for a period of 2 minutes. Char length is then measured as the original length of the specimen minus the distance from the top edge of the specimen to the horizontal line above which all material is intact.

Flame Resistance Requirements:

<u>Specimen Configuration</u>	<u>Maximum Char Length or Destroyed Material Length (mm)</u>	<u>Maximum Afterflame Time (s)</u>	<u>Duration of Flaming Drips on Floor of Tester (s)</u>
Folded	1050	2.0	2.0
Flat	435	2.0	2.0



Presented by the
University of Toronto
October 2016



SL100

TECHNICAL DRAWINGS

2016

Trailer Hitch Option A
Drawbar / Pintle Eye

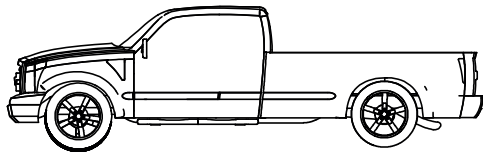
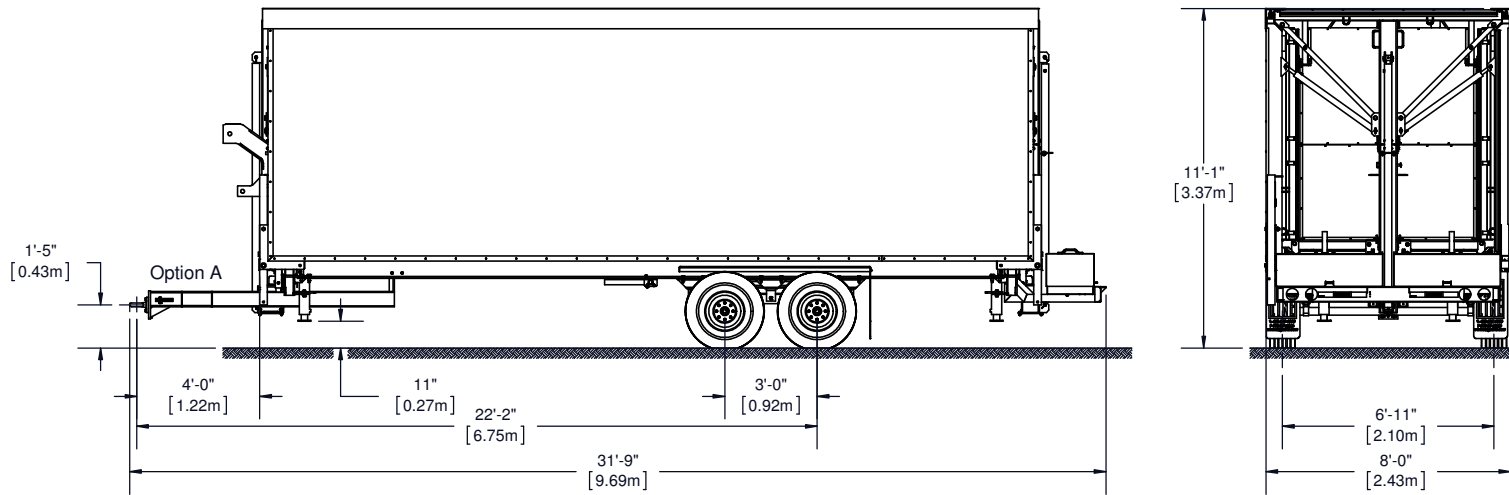

Mass SL100	Unladen		Standard Equipment		Maximum Capacity	
	Lbs	Kg	Lbs	Kg	Lbs	Kg
Total Mass	8752	3970	10604	4810	15000	6804
Mass on Axle	7496	3400	9171	4160	14000	6350
Mass on Hitch	1257	570	1433	650	3750	1701

Drawings may show stage equipped with optional accessories. May be sold separately.

© 2015 - R01 - All rights reserved, Stageline Mobile Stage Inc. Any and all forms of adaptation or reproduction of this document including plans and drawings, in whole or in part, are strictly forbidden without the written authorisation of Stageline Mobile Stage Inc. Mass may vary depending on options. Technical specifications may change without notice. Stage specifications subject to change without notice. Figures are nominal.

Trailer Hitch Option B
KingPin / Fifth Wheel

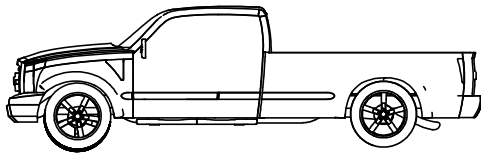
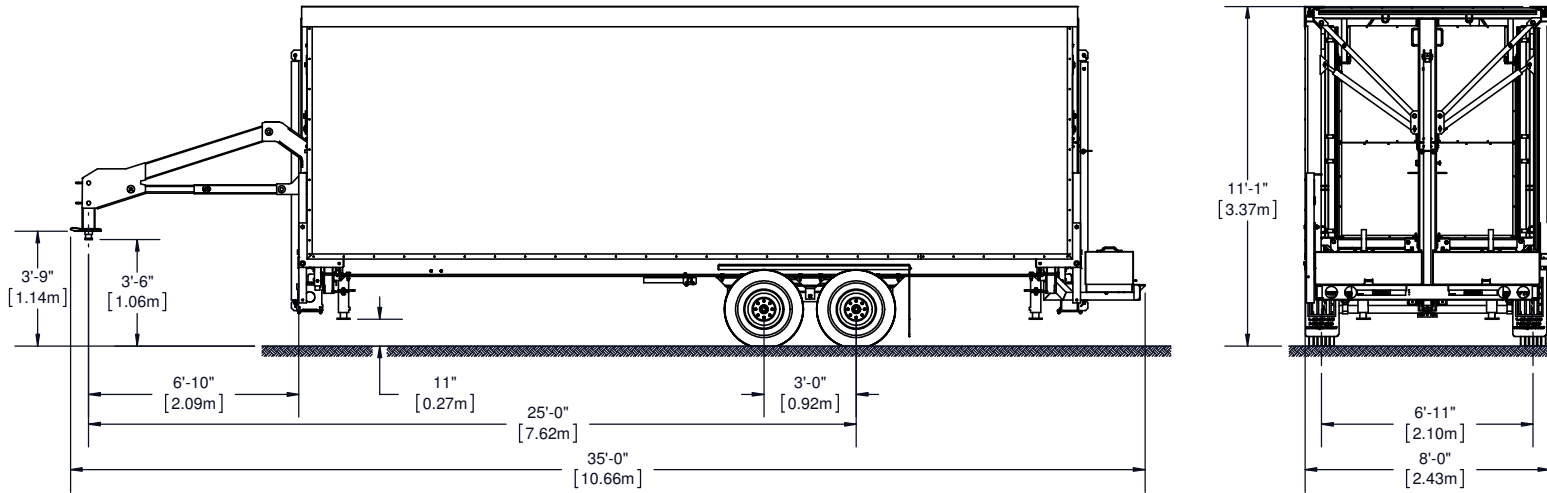

Mass SL100	Unladen		Standard Equipment		Maximum Capacity	
	Lbs	Kg	Lbs	Kg	Lbs	Kg
Total Mass	8752	3970	10604	4810	15000	6804
Mass on Axle	7496	3400	9171	4160	14000	6350
Mass on Hitch	1257	570	1433	650	3750	1701

Drawings may show stage equipped with optional accessories. May be sold separately.

© 2015 - R01 - All rights reserved, Stageline Mobile Stage Inc. Any and all forms of adaptation or reproduction of this document including plans and drawings, in whole or in part, are strictly forbidden without the written authorisation of Stageline Mobile Stage Inc. Mass may vary depending on options. Technical specifications may change without notice. Stage specifications subject to change without notice. Figures are nominal.

Trailer Hitch Option C
Gooseneck / Ball Hitch

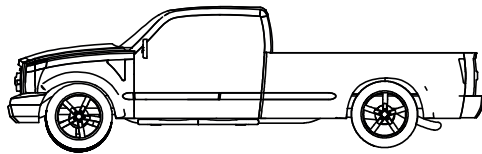
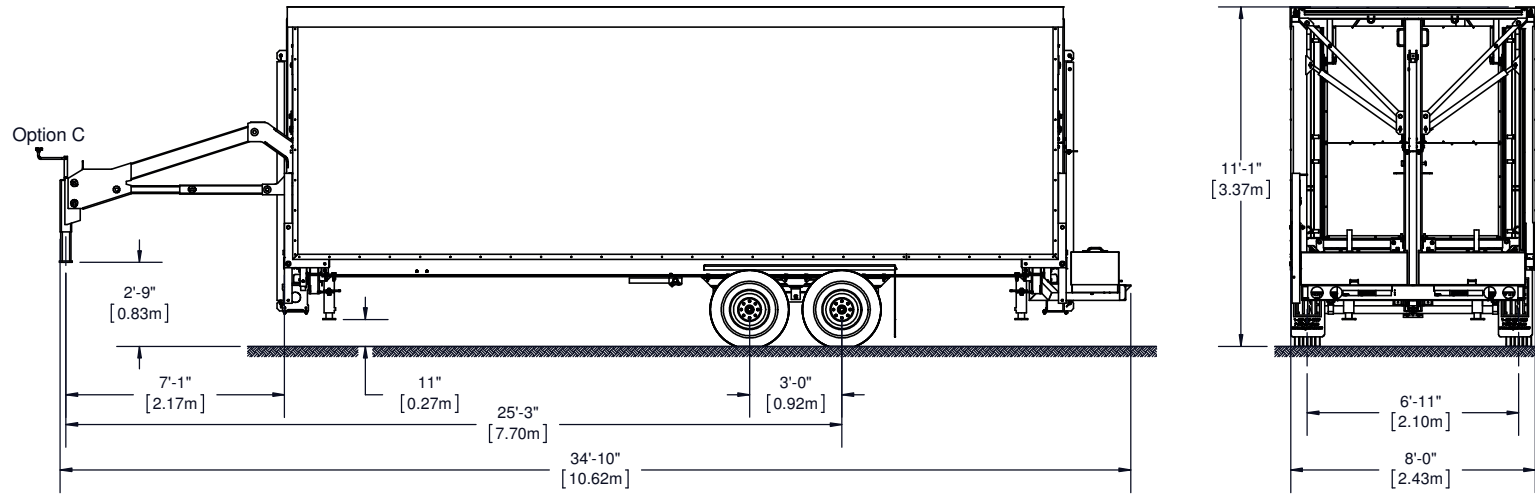

Mass SL100	Unladen		Standard Equipment		Maximum Capacity	
	Lbs	Kg	Lbs	Kg	Lbs	Kg
Total Mass	8752	3970	10604	4810	15000	6804
Mass on Axle	7496	3400	9171	4160	14000	6350
Mass on Hitch	1257	570	1433	650	3750	1701

Drawings may show stage equipped with optional accessories. May be sold separately.

© 2015 - R01 - All rights reserved, Stageline Mobile Stage Inc. Any and all forms of adaptation or reproduction of this document including plans and drawings, in whole or in part, are strictly forbidden without the written authorisation of Stageline Mobile Stage Inc. Mass may vary depending on options. Technical specifications may change without notice. Stage specifications subject to change without notice. Figures are nominal.

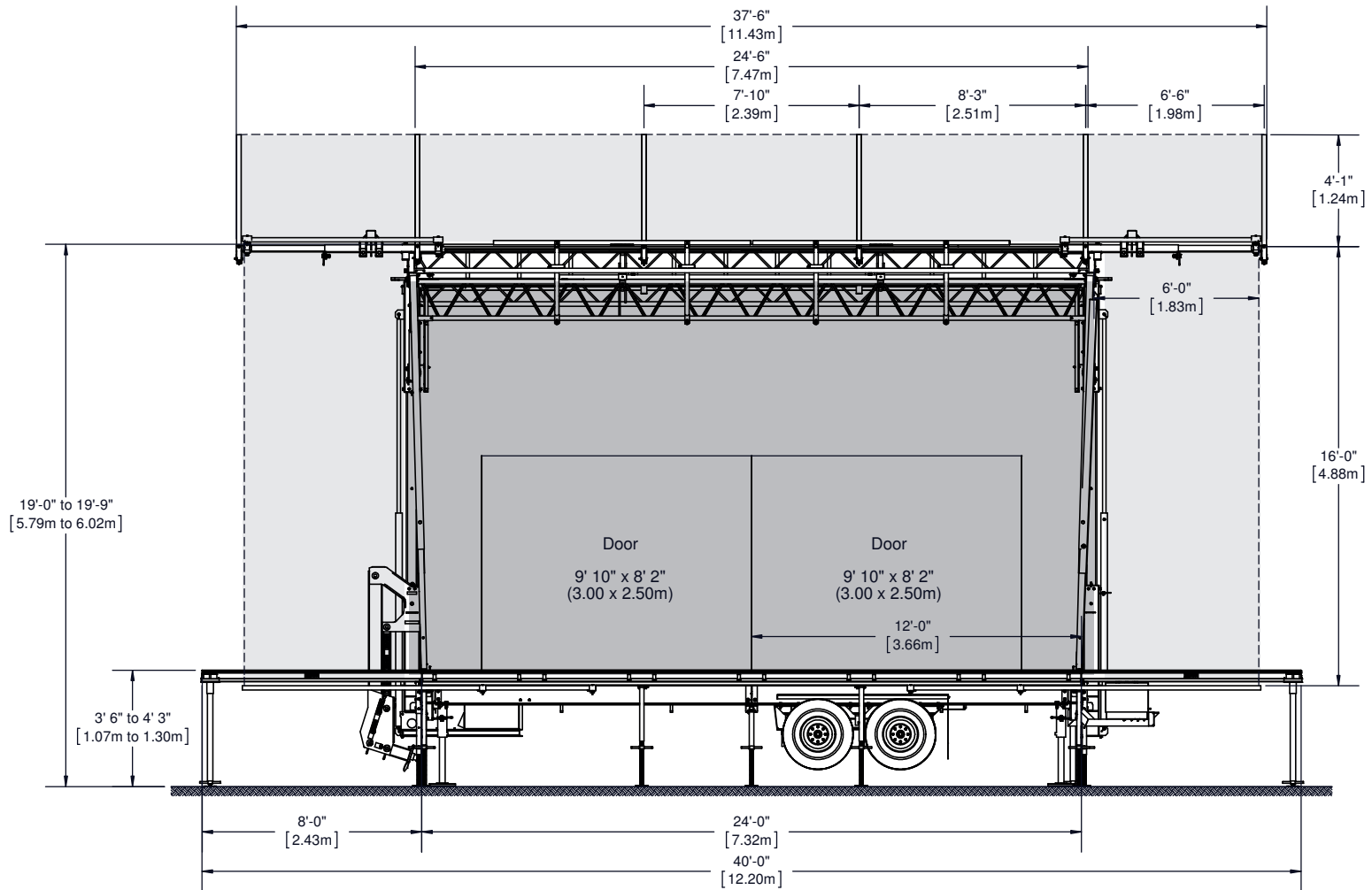

- WINDWALL
- BANNER (For dimensions, please refer to banner book)

Drawings may show stage equipped with optional accessories. May be sold separately.

© 2015 - R01 - All rights reserved, Stageline Mobile Stage Inc. Any and all forms of adaptation or reproduction of this document including plans and drawings, in whole or in part, are strictly forbidden without the written authorisation of Stageline Mobile Stage Inc. Mass may vary depending on options. Technical specifications may change without notice. Stage specifications subject to change without notice. Figures are nominal.

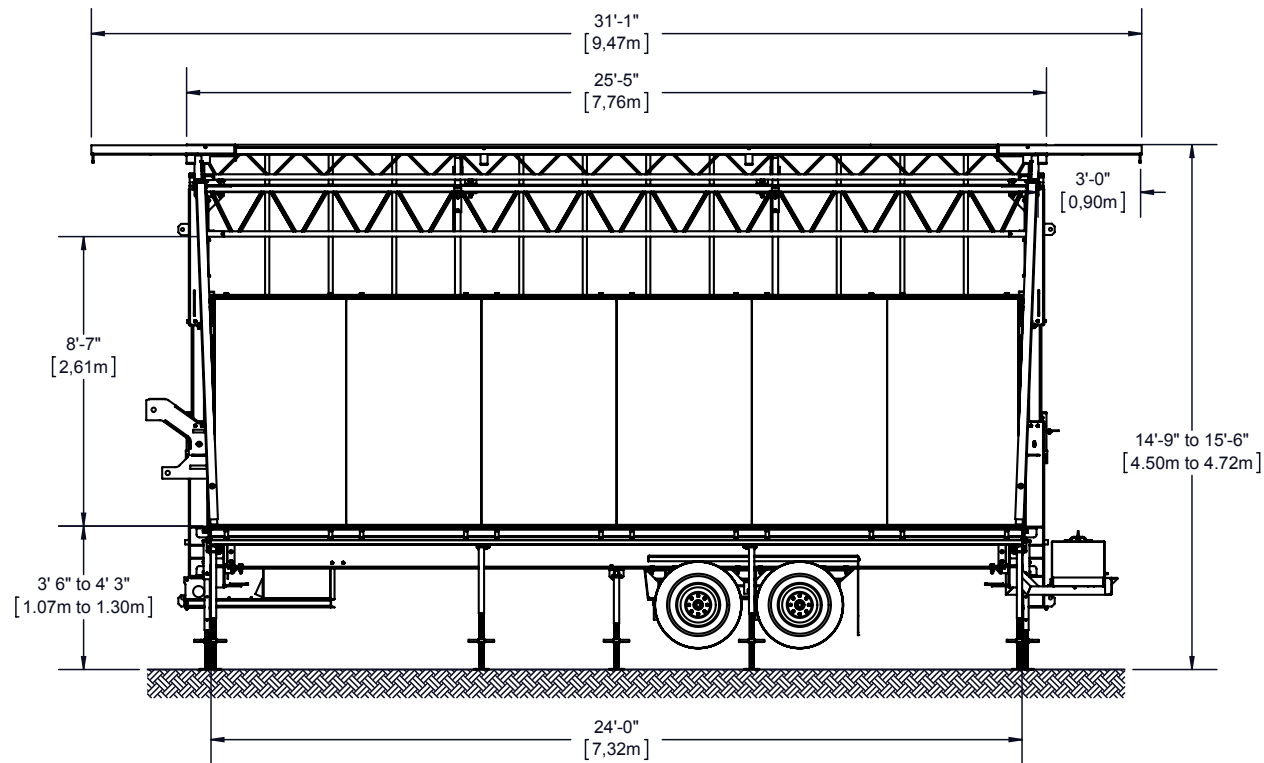

Drawings may show stage equipped with optional accessories. May be sold separately.

© 2015 - R01 - All rights reserved, Stageline Mobile Stage Inc. Any and all forms of adaptation or reproduction of this document including plans and drawings, in whole or in part, are strictly forbidden without the written authorisation of Stageline Mobile Stage Inc. Mass may vary depending on options. Technical specifications may change without notice. Stage specifications subject to change without notice. Figures are nominal.

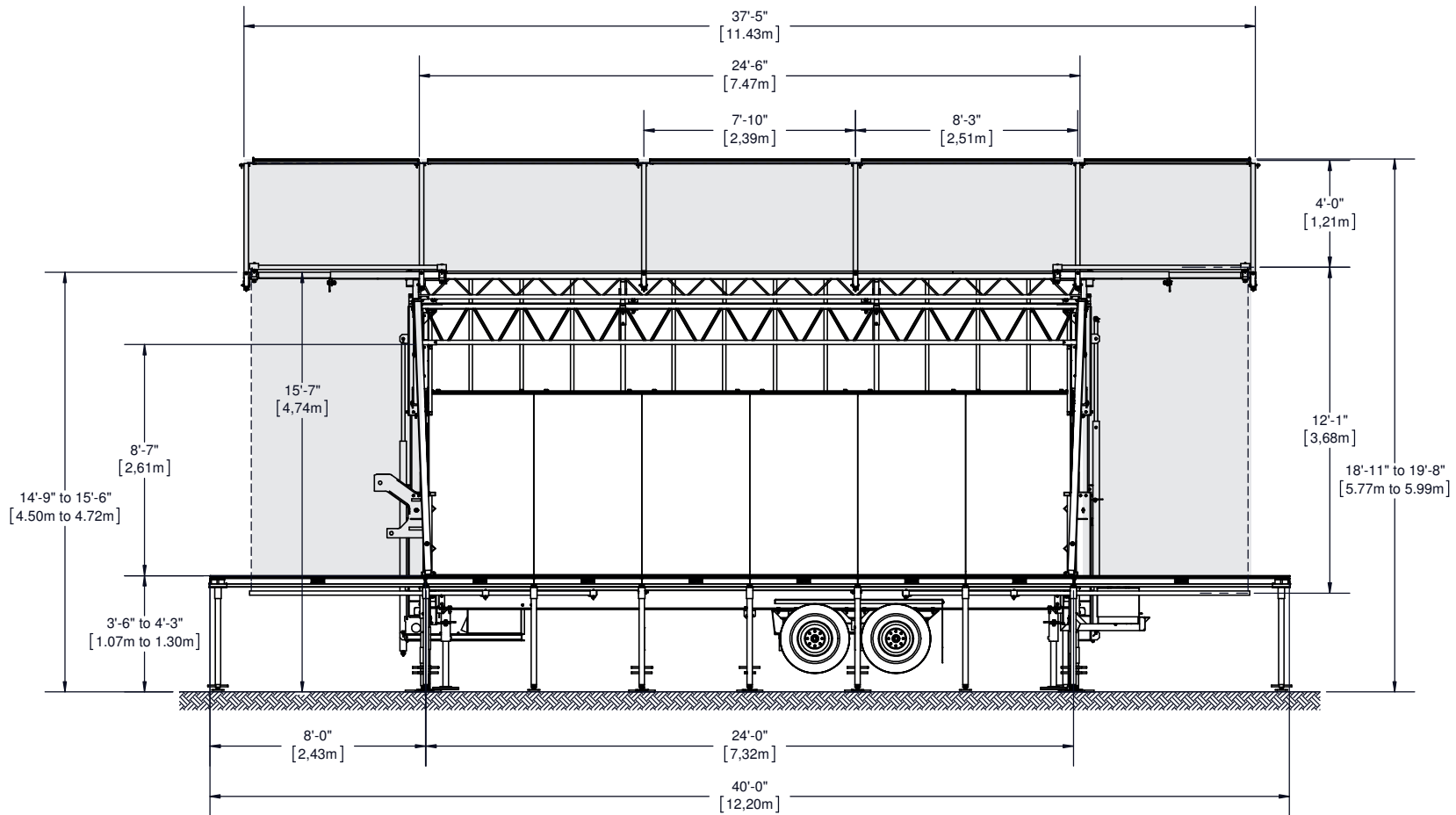

BANNER (For dimensions, please refer to banner book)

Drawings may show stage equipped with optional accessories. May be sold separately.

© 2015 - R01 - All rights reserved, Stageline Mobile Stage Inc. Any and all forms of adaptation or reproduction of this document including plans and drawings, in whole or in part, are strictly forbidden without the written authorisation of Stageline Mobile Stage Inc. Mass may vary depending on options. Technical specifications may change without notice. Stage specifications subject to change without notice. Figures are nominal.

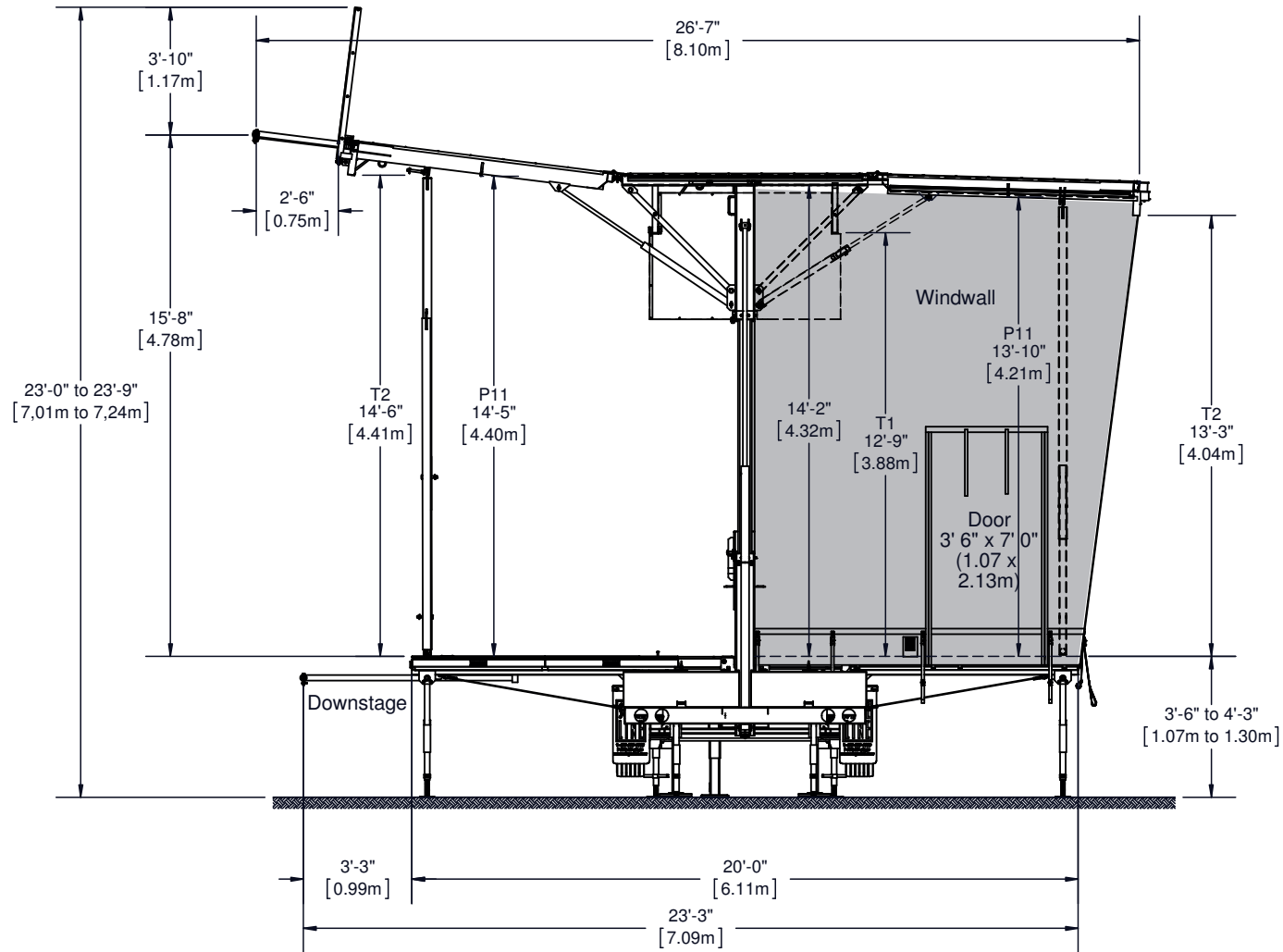

WINDWALL

Drawings may show stage equipped with optional accessories. May be sold separately.

© 2015 - R01 - All rights reserved, Stageline Mobile Stage Inc. Any and all forms of adaptation or reproduction of this document including plans and drawings, in whole or in part, are strictly forbidden without the written authorisation of Stageline Mobile Stage Inc. Mass may vary depending on options. Technical specifications may change without notice. Stage specifications subject to change without notice. Figures are nominal.

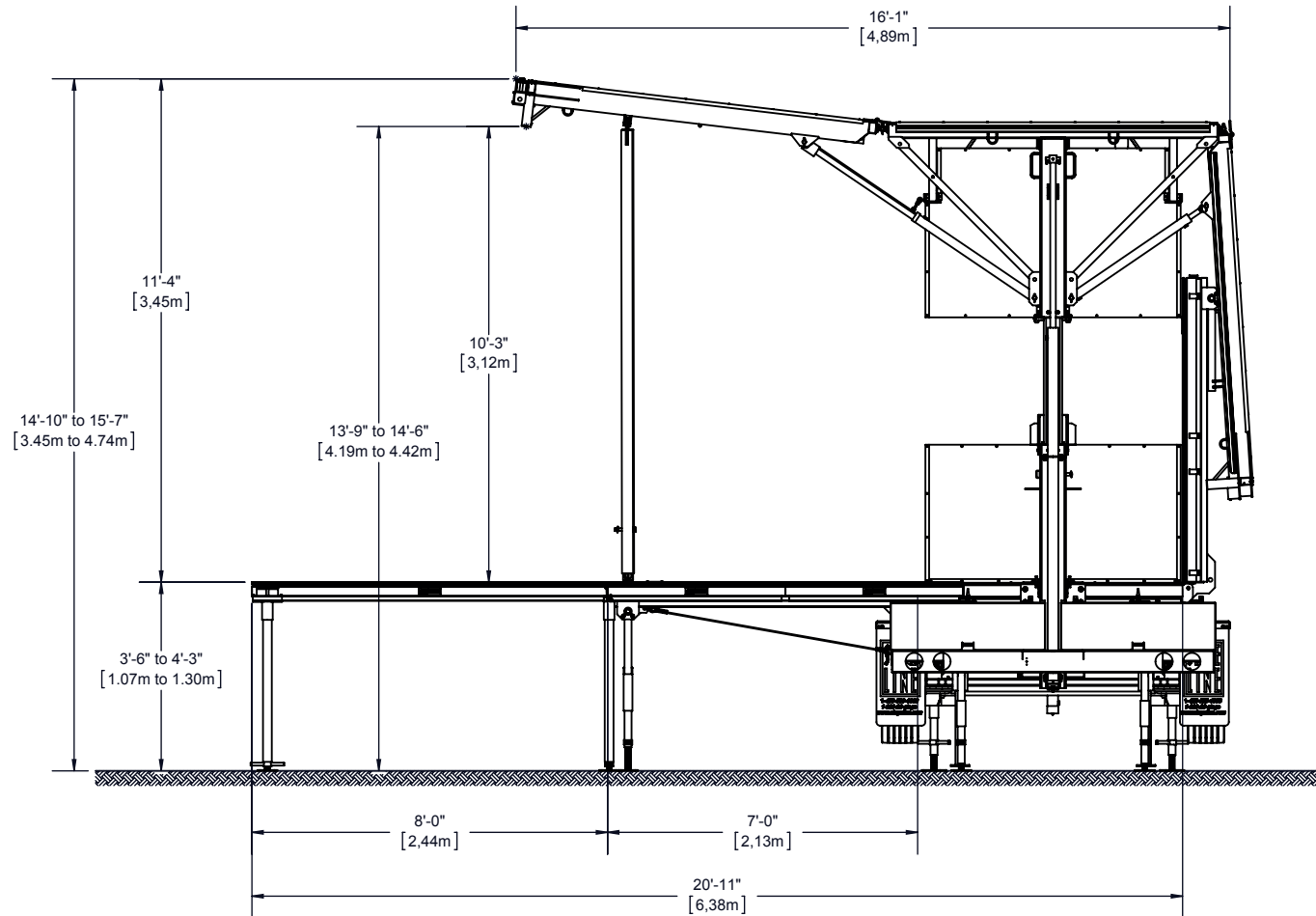

Drawings may show stage equipped with optional accessories. May be sold separately.

© 2015 - R01 - All rights reserved, Stageline Mobile Stage Inc. Any and all forms of adaptation or reproduction of this document including plans and drawings, in whole or in part, are strictly forbidden without the written authorisation of Stageline Mobile Stage Inc. Mass may vary depending on options. Technical specifications may change without notice. Stage specifications subject to change without notice. Figures are nominal.

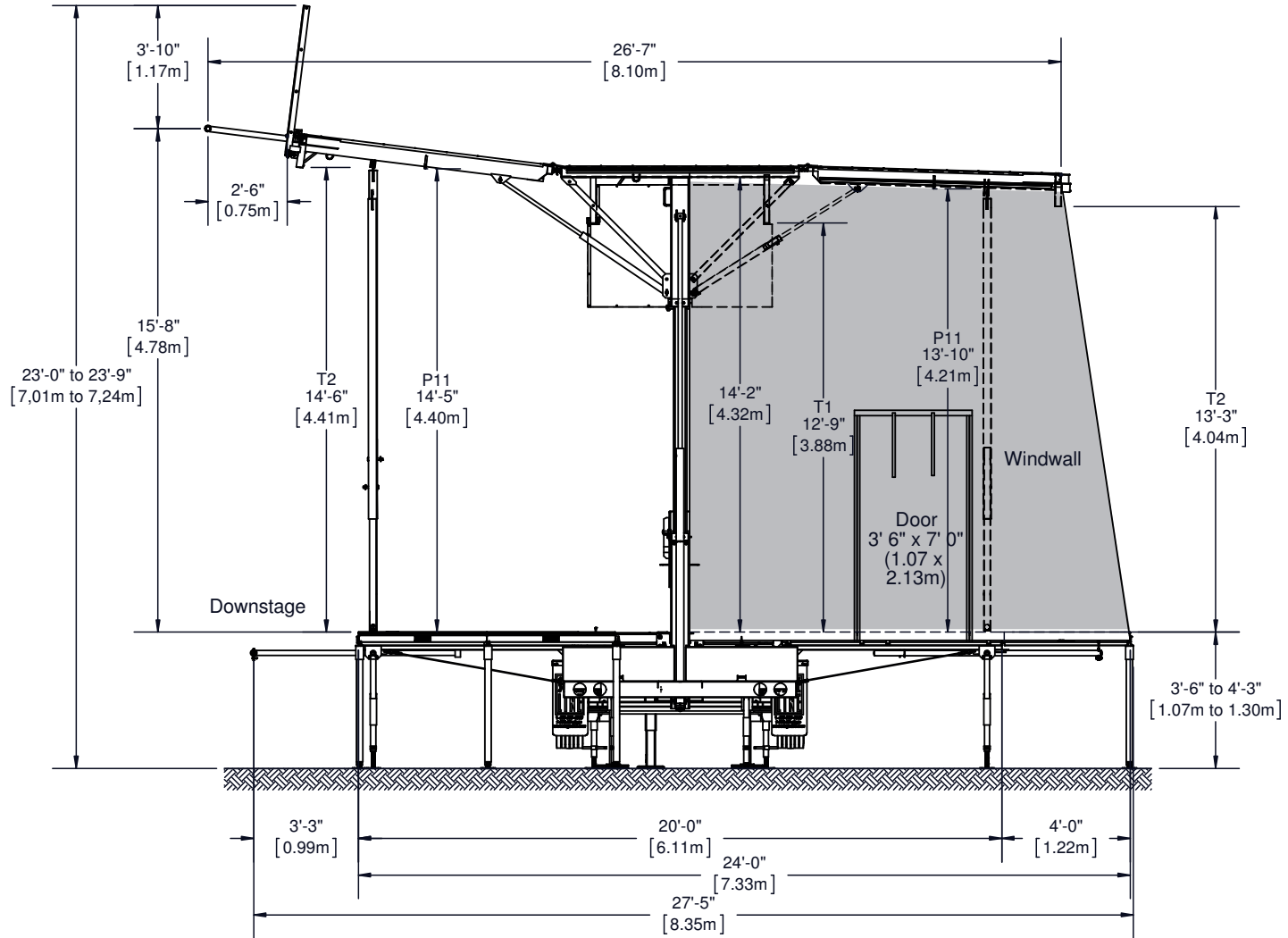

WINDWALL

Drawings may show stage equipped with optional accessories. May be sold separately.

© 2015 - R01 - All rights reserved, Stageline Mobile Stage Inc. Any and all forms of adaptation or reproduction of this document including plans and drawings, in whole or in part, are strictly forbidden without the written authorisation of Stageline Mobile Stage Inc. Mass may vary depending on options. Technical specifications may change without notice. Stage specifications subject to change without notice. Figures are nominal.

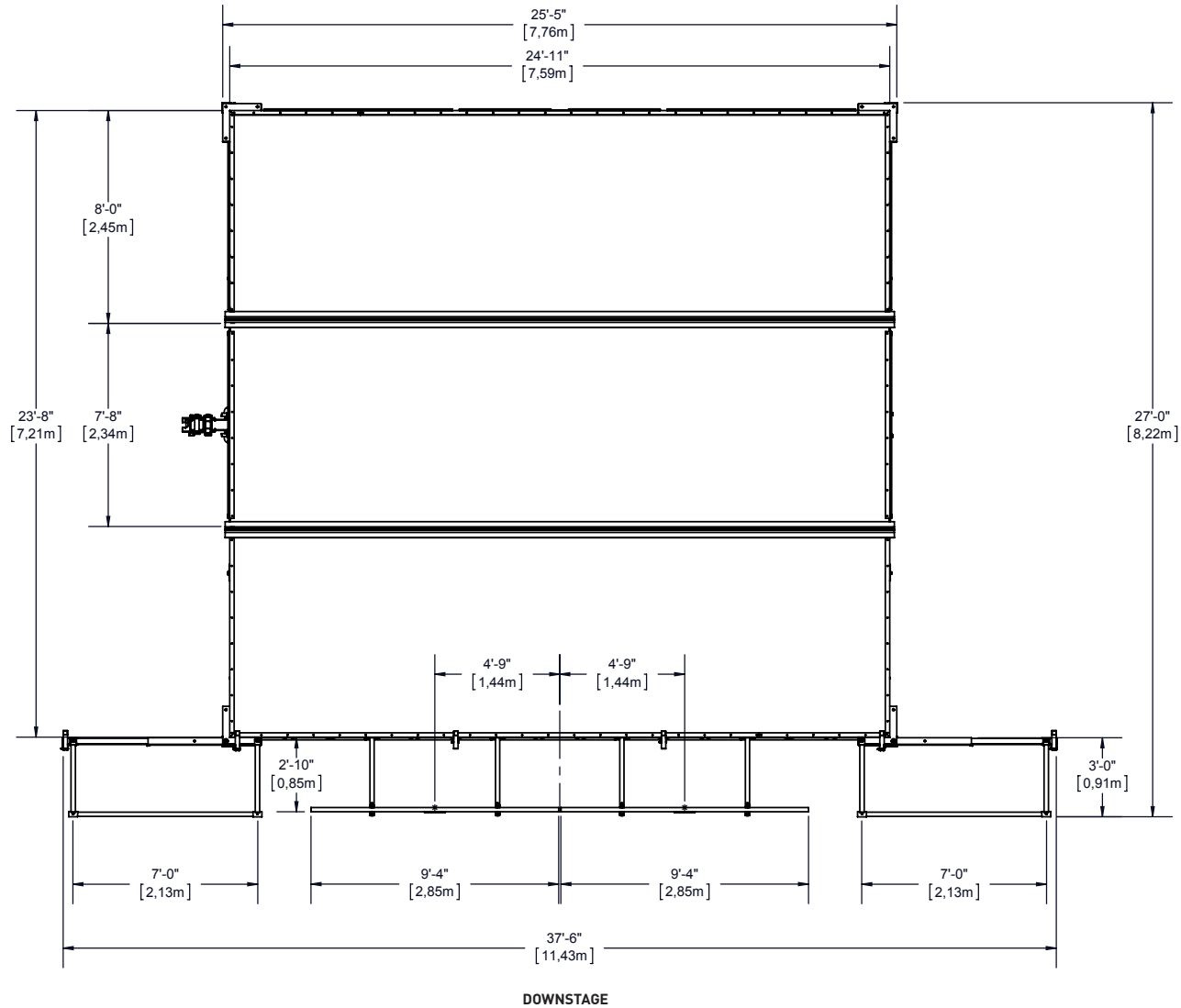

Drawings may show stage equipped with optional accessories. May be sold separately.

© 2015 - R01 - All rights reserved, Stageline Mobile Stage Inc. Any and all forms of adaptation or reproduction of this document including plans and drawings, in whole or in part, are strictly forbidden without the written authorisation of Stageline Mobile Stage Inc. Mass may vary depending on options. Technical specifications may change without notice. Stage specifications subject to change without notice. Figures are nominal.

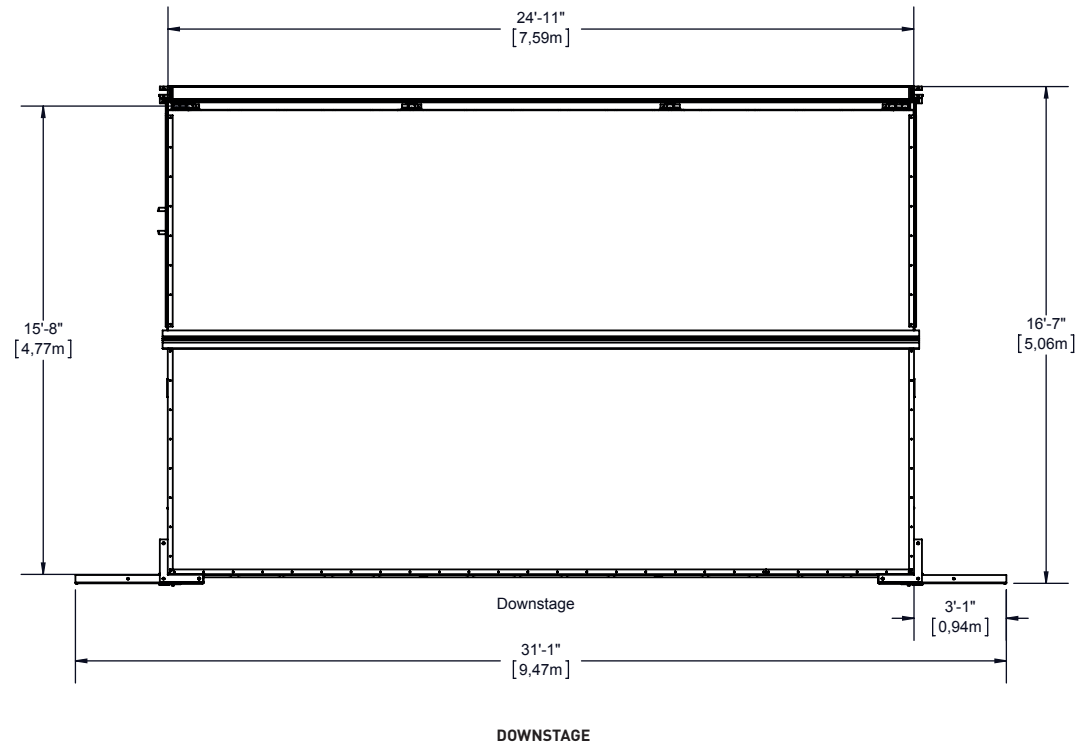

Drawings may show stage equipped with optional accessories. May be sold separately.

© 2015 - R01 - All rights reserved, Stageline Mobile Stage Inc. Any and all forms of adaptation or reproduction of this document including plans and drawings, in whole or in part, are strictly forbidden without the written authorisation of Stageline Mobile Stage Inc. Mass may vary depending on options. Technical specifications may change without notice. Stage specifications subject to change without notice. Figures are nominal.

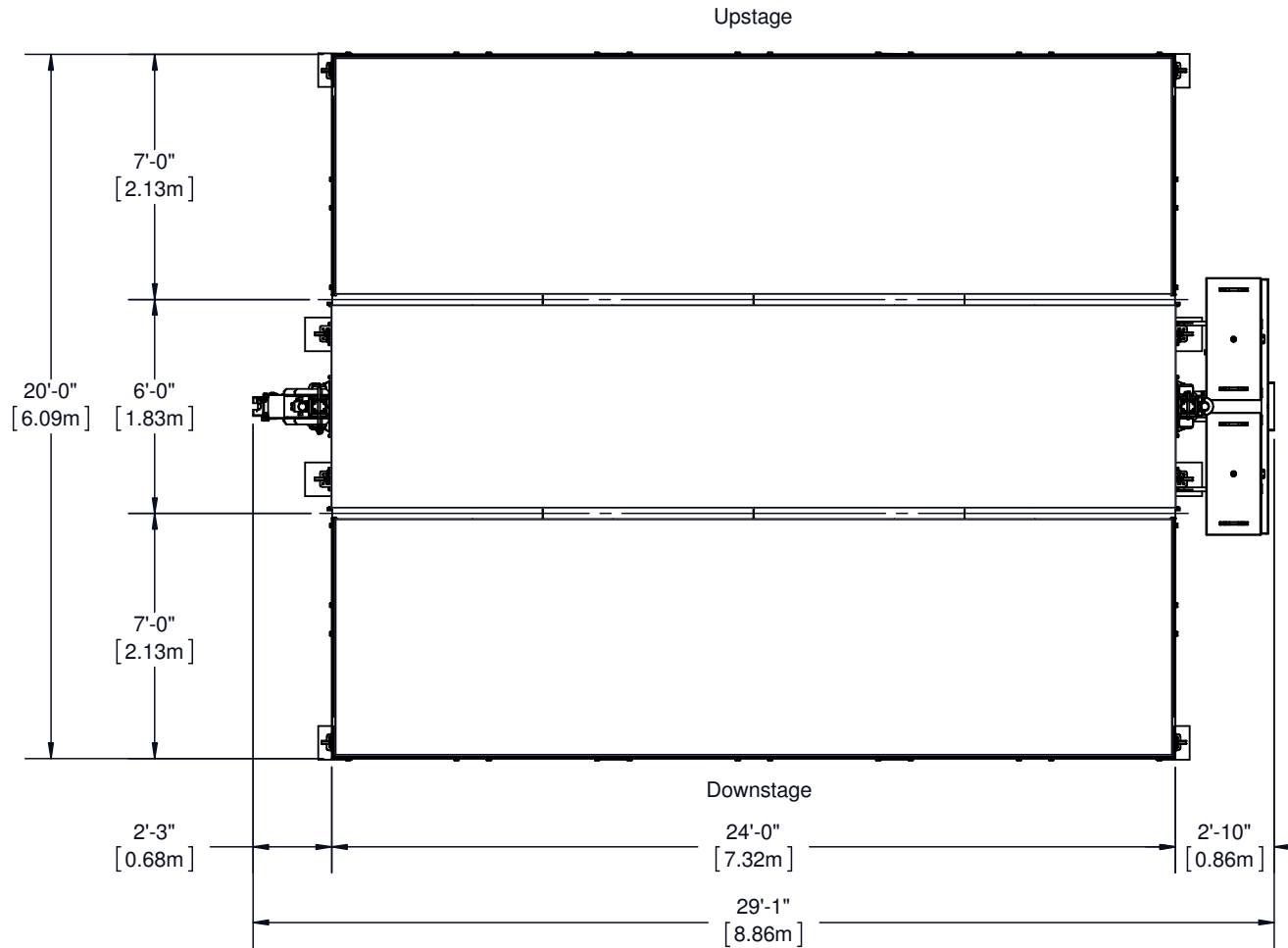

CAPACITY: 100lbs/ft² (490kg./m²)

Drawings may show stage equipped with optional accessories. May be sold separately.

© 2015 - R01 - All rights reserved, Stageline Mobile Stage Inc. Any and all forms of adaptation or reproduction of this document including plans and drawings, in whole or in part, are strictly forbidden without the written authorisation of Stageline Mobile Stage Inc. Mass may vary depending on options. Technical specifications may change without notice. Stage specifications subject to change without notice. Figures are nominal.

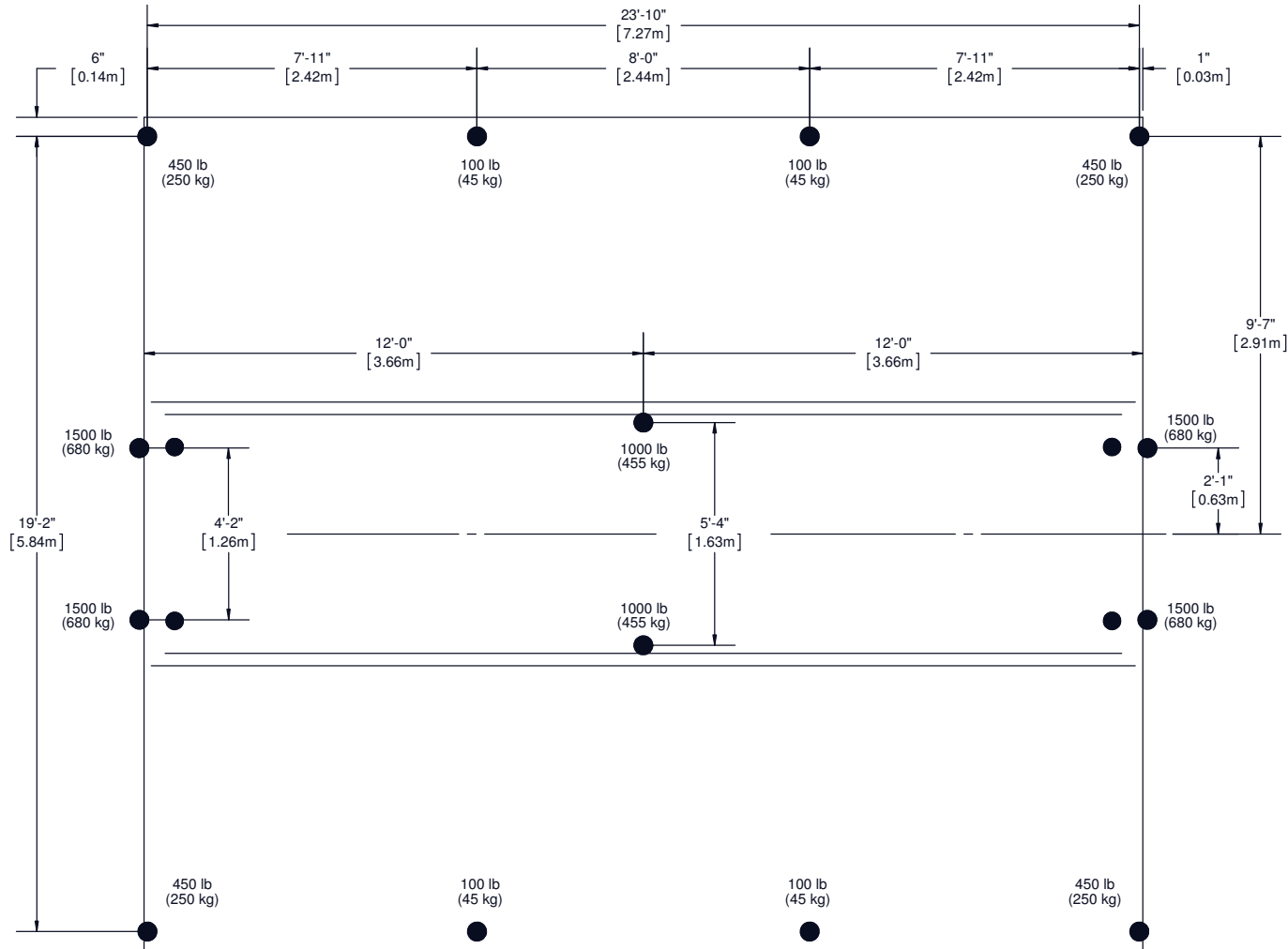

● FLOOR STABILIZERS, EXTENSIONS AND LEVELLING JACKS

Drawings may show stage equipped with optional accessories. May be sold separately.

© 2015 - R01 - All rights reserved, Stageline Mobile Stage Inc. Any and all forms of adaptation or reproduction of this document including plans and drawings, in whole or in part, are strictly forbidden without the written authorisation of Stageline Mobile Stage Inc. Mass may vary depending on options. Technical specifications may change without notice. Stage specifications subject to change without notice. Figures are nominal.

Bandshell Configurations

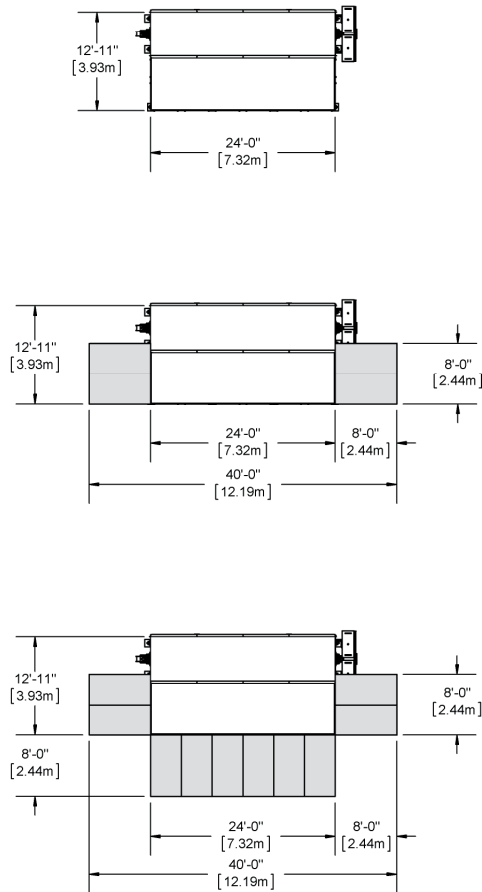

Standard Configurations

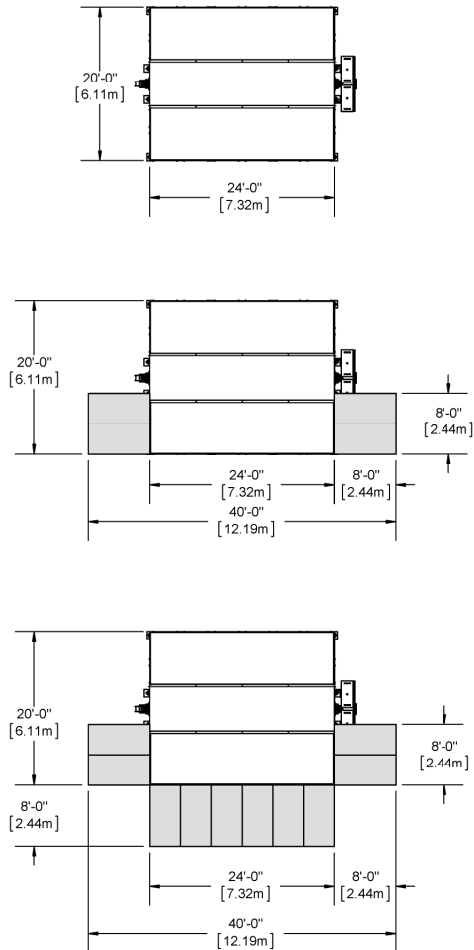

Extended Configurations

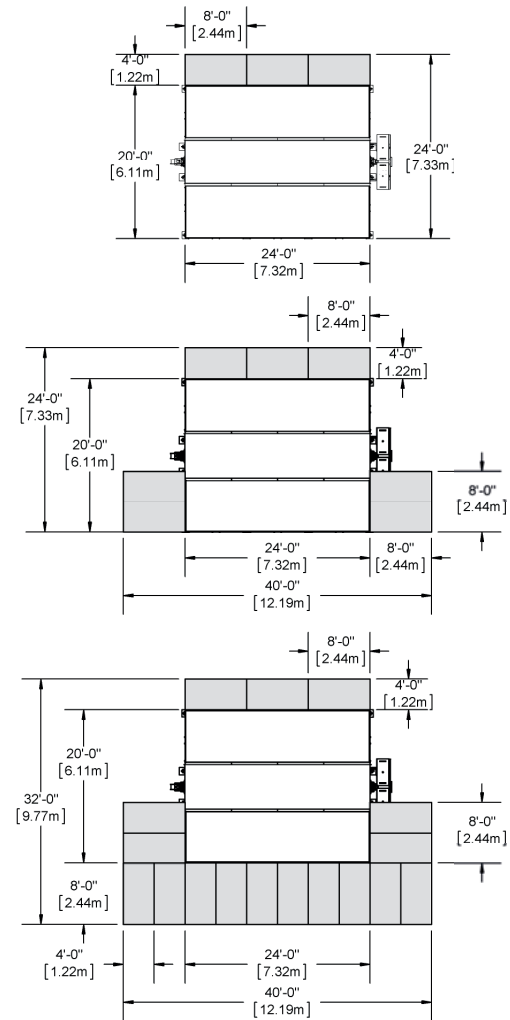

PLATFORM 4'-0" x 8'-0" [1.22m x 2.44m]

Drawings may show stage equipped with optional accessories. May be sold separately.

© 2015 - R01 - All rights reserved, Stageline Mobile Stage Inc. Any and all forms of adaptation or reproduction of this document including plans and drawings, in whole or in part, are strictly forbidden without the written authorisation of Stageline Mobile Stage Inc. Mass may vary depending on options. Technical specifications may change without notice. Stage specifications subject to change without notice. Figures are nominal.

A thorough understanding of the inter-related loadings shown in this rigging plan is needed in order to safely use this mobile stage roof and to take full advantage of the many rigging opportunities it offers.

This mobile stage roof offers a variety of rigging options with regard to load capacity, placement and type.

There are a rigging pipe, trusses, roof rigging points and side overhang rigging beams.

This rigging plan locates and defines these rigging features, includes load capacity for each and describes maximum combinations of loads amongst features.

Take note of exclusions, maximum sub-totals in a group, load balance requirements, maximum lifting capacity of roof and maximum rigging load on roof.

The maximum load on the roof is less than the sum of the maximum load on each rigging feature.

RIGGING RESTRICTIONS:

- Use P1s,P2s,P3s,P4s OR P 5 on each T1 truss, maximum load of 1250lb.
- Use P6s,P7s,P8s,P9s or P1 0 on each T2 truss, maximum load of 500lb.
- Do not load more than 30 lb/lin. ft (45 kg/lin. m) on rigging pipe. All loads should be uniformly distributed.
- Do not load more than 250 lb (115 kg) concurrently on P6s to P12s. When downstage corner posts are replaced by cylinder lock.

** Total loads on P12s, P13s can be increased to 800 lb (363kg) once all corner posts have been installed and no banner supports installed. Max. of 125 lb (57kg) can be loaded at any place along each FOH pipe. T2 capacity must be reduce to account for these loading.

*** Optional items, see stage specifications.

MAXIMUM ROOF LIFTING CAPACITY: 3800 LB (1725 KG)

LIFTING RESTRICTIONS

- Total load on T2 and P12s must not exceed 500 lb (227 kg) when using downstage P11s.
- Total load on T2 and P12s can be increased to 850 lb to (380 kg) if not using downstage P11s.
- Except for P10, all rigging points on T2 must be used in pairs such that total load will be evenly divided on the roof hydraulic struts.
- Maximum assymetric load difference between downstage and upstage roof must not exceed 1550 lb (705 kg)

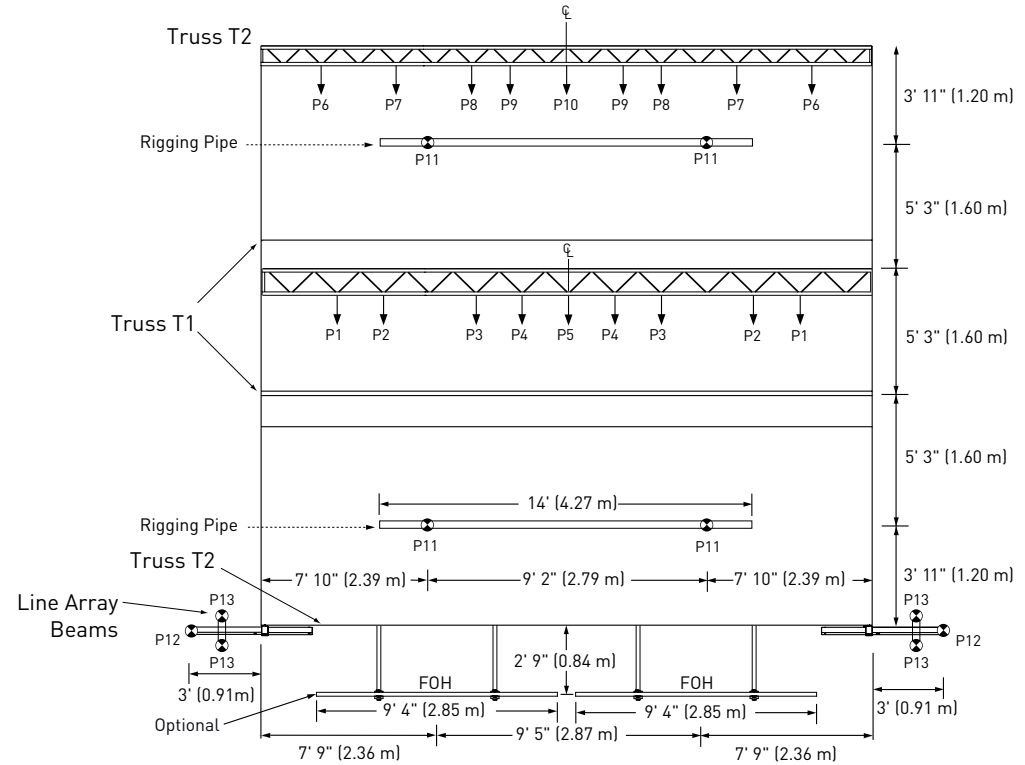

MAXIMUM LOAD BEARING CAPACITY: 6500 lb (2948 kg)*

*All corner posts must be installed and pinned.

MAXIMUM LOAD CAPACITY		
Point No.	Lbs	Kg
P1, P2, P3	625	283
P4, P5,	500	227
P12, P13 **	425	190
P11,	350	159
P6, P7, P8	250	113
P9, P10	175	79
FOH ***	125	57

Drawings may show stage equipped with optional accessories. May be sold separately.

© 2015 - R01 - All rights reserved, Stageline Mobile Stage Inc. Any and all forms of adaptation or reproduction of this document including plans and drawings, in whole or in part, are strictly forbidden without the written authorisation of Stageline Mobile Stage Inc. Mass may vary depending on options. Technical specifications may change without notice. Stage specifications subject to change without notice. Figures are nominal.