

3 to 12.5 Ton Unit Physical Dimensions

| Unit Model Number | Dimension (in.) | | | | | |
|---------------------------|-----------------|---------|---------|---------|---------|--------|
| | A | B | C | D | E | F |
| ZS -06, -07 | 42 | 89 | 22 1/8 | 18 3/16 | 15 3/16 | 6 3/16 |
| ZS-08, -10 | 50 3/4 | 89 | 30 3/16 | 24 3/16 | 17 3/16 | 6 3/16 |
| ZS-12 | 50 3/4 | 119 1/2 | 30 3/16 | 24 3/16 | 17 3/16 | 6 3/16 |
| ZU-A3, -A4, -A5, -06, -07 | 42 | 89 | 22 1/8 | 18 3/16 | 15 3/16 | 6 3/16 |
| ZU-08, -10 | 50 3/4 | 89 | 30 3/16 | 24 3/16 | 17 3/16 | 6 3/16 |
| ZU-12 | 50 3/4 | 119 1/2 | 30 3/16 | 24 3/16 | 17 3/16 | 6 3/16 |
| ZW-A3, -A4, -A5 | 42 | 89 | 22 1/8 | 18 3/16 | 15 3/16 | 6 3/16 |
| ZW-06, -07, -08, -10 | 50 3/4 | 89 | 30 3/16 | 24 3/16 | 17 3/16 | 6 3/16 |
| ZW-12 | 50 3/4 | 119 1/2 | 30 3/16 | 24 3/16 | 17 3/16 | 6 3/16 |
| ZK-A3, -A4, -A5 | 42 | 89 | 22 1/8 | 18 3/16 | 15 3/16 | 6 3/16 |
| ZK-06, -07 | 42 | 89 | 22 1/8 | 18 3/16 | 15 3/16 | 6 3/16 |
| ZK-08, -10 | 50 3/4 | 89 | 30 3/16 | 24 3/16 | 17 3/16 | 6 3/16 |
| ZK-12 | 50 3/4 | 119 1/2 | 30 3/16 | 24 3/16 | 17 3/16 | 6 3/16 |

Detail A

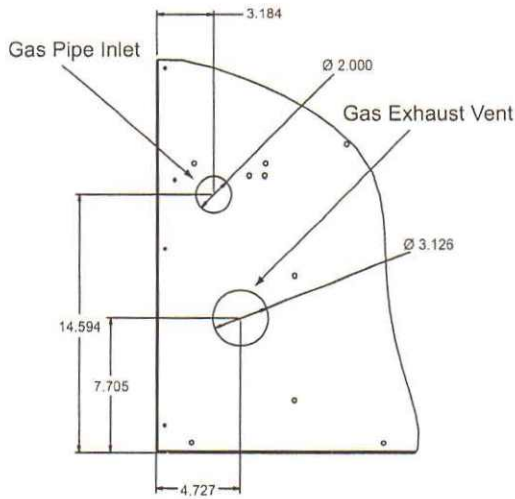

42" CABINET

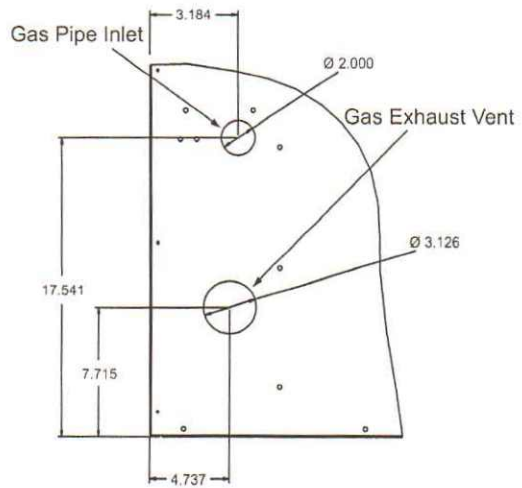

50 3/4" CABINET

Detail B

