

© 2013 RYAN SENATORE ARCHITECTURE

STRAND BUILDING - FACADE RENOVATION  
565 CONGRESS STREET  
PORTLAND, MAINE



RYAN SENATORE ARCHITECTURE  
67 GRAY ROAD  
GORHAM, MAINE 04038  
207-650-6414  
senatorearchitecture.com

CONSULTANTS:

REVISIONS:

DATE: JUNE 27, 2013

PROJECT No.

DRAWN BY:

CHECKED BY: RJS

SCALE: AS NOTED

SHEET TITLE:

ALTERNATE #1  
CANOPY  
DETAILS

A3-1

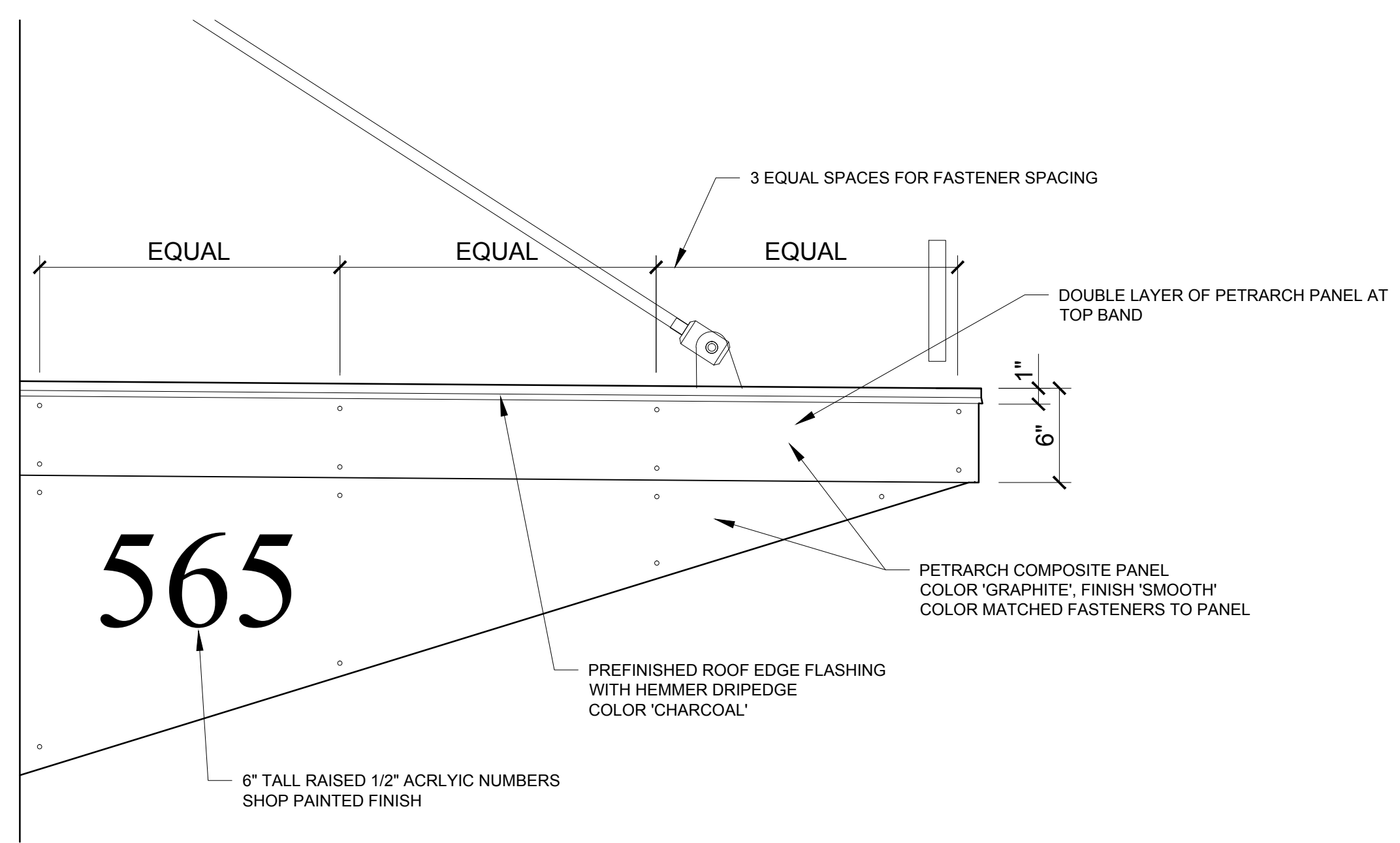

2 CANOPY SIDE ELEVATION DETAIL (OTHER SIDE SIMILAR)  
1:12" = 1'-0"

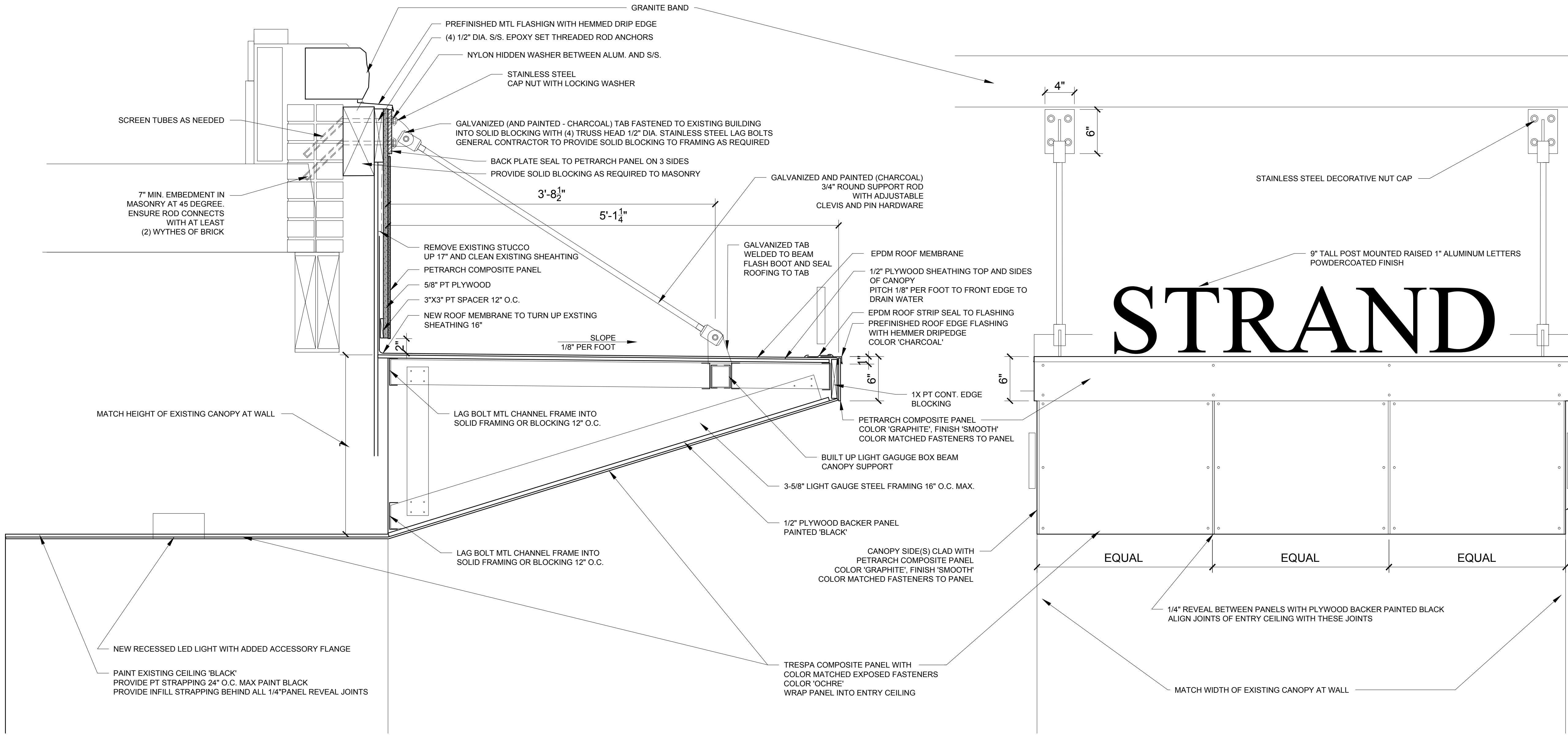

2 SECTION DETAIL  
1:12" = 1'-0"

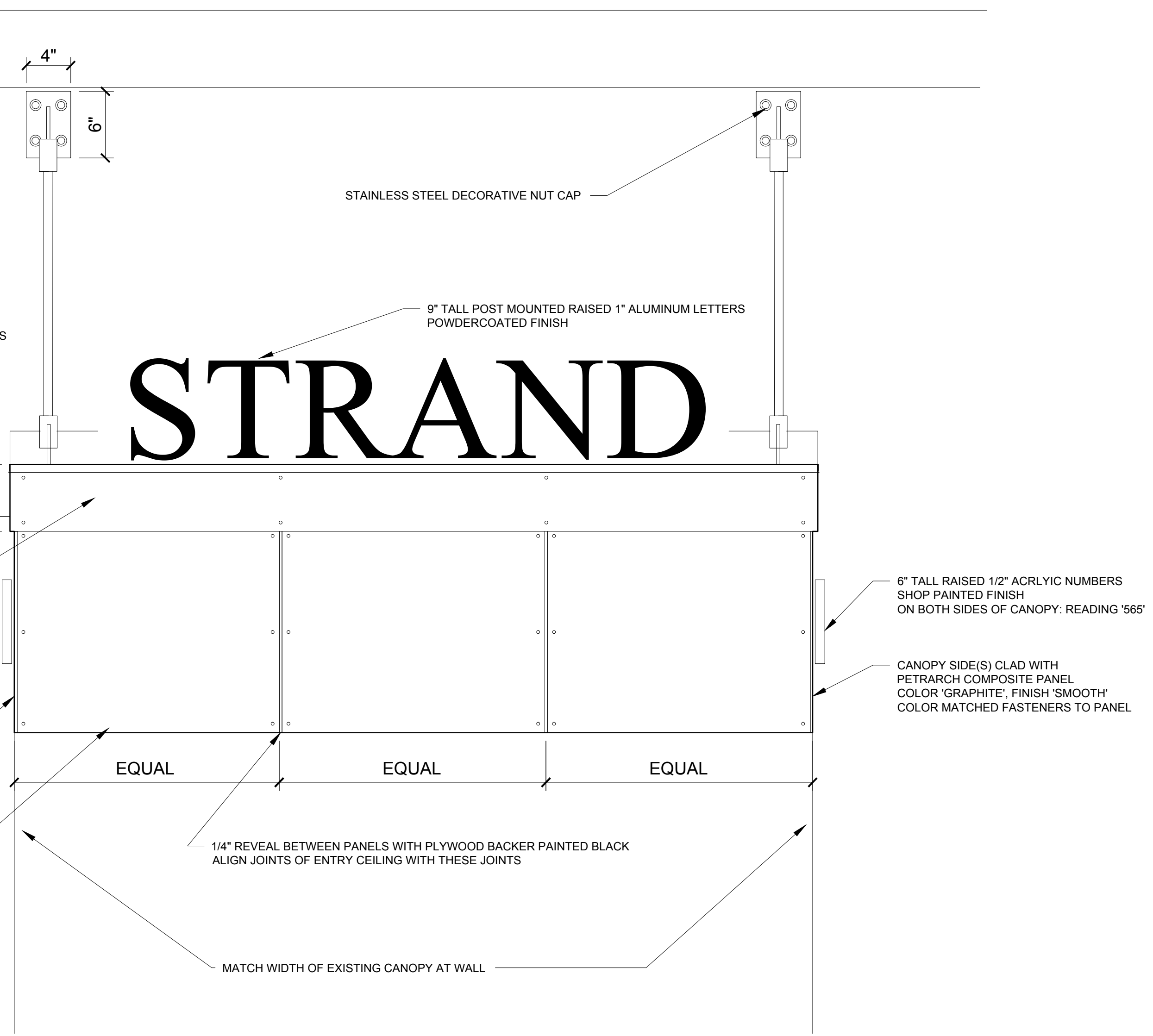

1 ELEVATION DETAIL  
1:12" = 1'-0"