

DISPLAY THIS CARD ON PRINCIPAL FRONTAGE OF WORK
CITY OF PORTLAND

BUILDING INSPECTION

PERMIT ISSUED

Please Read Application And Notes, If Any, Attached

Permit Number: 091386

JAN 20 2010

This is to certify that PORTLAND STAGE COMPANY / Lebel's /Lebel's

has permission to install hood system

AT 25 FOREST AVE CB# 037 A022001 City of Portland

provided that the person or persons, firm or corporation accepting this permit shall comply with all of the provisions of the Statutes of Maine and of the Ordinances of the City of Portland regulating the construction, maintenance and use of buildings and structures, and of the application on file in this department.

Apply to Public Works for street line and grade if nature of work requires such information.

Notification of inspection must be given and written permission procured before this building or part thereof is lathed or otherwise finished-in. 24 HOUR NOTICE IS REQUIRED.

A certificate of occupancy must be procured by owner before this building or part thereof is occupied.

OTHER REQUIRED APPROVALS
Fire Dept. [Signature]
Health Dept. [Signature]
Appeal Board _____
Other _____
Department Name _____

[Signature] 1/19/10
Director - Building & Inspection Services

PENALTY FOR REMOVING THIS CARD



General Building Permit Application

If you or the property owner owes real estate or personal property taxes or user charges on any property within the City, payment arrangements must be made before permits of any kind are accepted.

Location/Address of Construction: <u>27 Forest Ave</u>		
Total Square Footage of Proposed Structure/Area	Square Footage of Lot	Number of Stories
Tax Assessor's Chart, Block & Lot Chart# <u>37</u> Block# <u>A</u> Lot# <u>92</u>	Applicant * must be owner, Lessee or Buyer * Name <u>Becky</u> Address <u>27 Forest Ave</u> City, State & Zip <u>Portland Me</u>	Telephone:
Lessee/DBA (If Applicable) RECEIVED DEC -7 2009	Owner (if different from Applicant) Name Address City, State & Zip	Cost Of Work: \$ <u>7,800.00</u> C of O Fee: \$ _____ Total Fee: \$ <u>100</u>
Current legal use: <u>Dept. of Building Inspections</u> Number of Residential Units _____ If vacant, what was the previous use? <u>City of Portland Maine BAKERY</u> Proposed Specific use: <u>RESTAURANT</u> Is property part of a subdivision? <u>NO</u> If yes, please name _____ Project description: <u>Install Hood system Kitahdon Rest.</u>		
Contractor's name: <u>Lebel's Sheet Metal</u> Address: <u>221 Lincoln St.</u> City, State & Zip: <u>Lew. Me 04240</u> Telephone: <u>207-782-2235</u> Who should we contact when the permit is ready: <u>PAUL ROY</u> Telephone: <u>207-576-1863</u> Mailing address: <u>221 Lincoln St.</u>		

Please submit all of the information outlined on the applicable Checklist. Failure to do so will result in the automatic denial of your permit.

In order to be sure the City fully understands the full scope of the project, the Planning and Development Department may request additional information prior to the issuance of a permit. For further information or to download copies of this form and other applications visit the Inspections Division on-line at www.portlandmaine.gov, or stop by the Inspections Division office, room 315 City Hall or call 874-8703.

I hereby certify that I am the Owner of record of the named property, or that the owner of record authorizes the proposed work and that I have been authorized by the owner to make this application as his/her authorized agent. I agree to conform to all applicable laws of this jurisdiction. In addition, if a permit for work described in this application is issued, I certify that the Code Official's authorized representative shall have the authority to enter all areas covered by this permit at any reasonable hour to enforce the provisions of the codes applicable to this permit.

Signature: Paul Roy Date: 12/7/09

This is not a permit; you may not commence ANY work until the permit is issue

City of Portland, Maine - Building or Use Permit Application

389 Congress Street, 04101 Tel: (207) 874-8703, Fax: (207) 874-8716

Permit No: 09-1386	Issue Date:	CBL: 037 A022001
-----------------------	-------------	---------------------

Location of Construction: 25 FOREST AVE (Called "27")	Owner Name: PORTLAND STAGE COMPANY	Owner Address: PO BOX 1458	Phone:
Business Name: KATAHDIN	Contractor Name: Lebels Sheet Metal	Contractor Address: 221 Lincoln Street Lewiston	Phone: 2072124019
Lessee/Buyer's Name	Phone:	Permit Type: Hood Systems, Commerical	Zone: B-3C

Past Use: Commercial - "Kathahdin" restaurant	Proposed Use: Commercial - "Kathahdin" restaurant - install hood system	Permit Fee:	Cost of Work: \$7,800.00	CEO District: 1
		FIRE DEPT: w/conditions 1/19/10 <input checked="" type="checkbox"/> Approved <input type="checkbox"/> Denied	INSPECTION: Use Group: A-2 Type: Hood IMC-2063	

Proposed Project Description: install hood system	Signature: <i>[Signature]</i>	Signature: <i>[Signature]</i> 1/19/10
PEDESTRIAN ACTIVITIES DISTRICT (P.A.D.)		
Action: <input type="checkbox"/> Approved <input type="checkbox"/> Approved w/Conditions <input type="checkbox"/> Denied		
Signature: _____ Date: _____		

Permit Taken By: Ldobson	Date Applied For: 12/07/2009	Zoning Approval	
-----------------------------	---------------------------------	------------------------	--

<p>1. This permit application does not preclude the Applicant(s) from meeting applicable State and Federal Rules.</p> <p>2. Building permits do not include plumbing, septic or electrical work.</p> <p>3. Building permits are void if work is not started within six (6) months of the date of issuance. False information may invalidate a building permit and stop all work..</p>	<p>Special Zone or Reviews</p> <input type="checkbox"/> Shoreland <input type="checkbox"/> Wetland <input type="checkbox"/> Flood Zone <input type="checkbox"/> Subdivision <input type="checkbox"/> Site Plan <p>Maj <input type="checkbox"/> Minor <input type="checkbox"/> MM <input type="checkbox"/></p> <p>Date: <i>[Signature]</i> 12/7/09</p>	<p>Zoning Appeal</p> <input type="checkbox"/> Variance <input type="checkbox"/> Miscellaneous <input type="checkbox"/> Conditional Use <input type="checkbox"/> Interpretation <input type="checkbox"/> Approved <input type="checkbox"/> Denied <p>Date: _____</p>	<p>Historic Preservation</p> <input type="checkbox"/> Not in District or Landmark <input type="checkbox"/> Does Not Require Review <input type="checkbox"/> Requires Review <input checked="" type="checkbox"/> Approved <input type="checkbox"/> Approved w/Conditions <input type="checkbox"/> Denied <p>Date: 12/21/09 <i>[Signature]</i></p>
---	---	---	--

PERMIT ISSUED

JAN 20 2010

City of Portland

CERTIFICATION

I hereby certify that I am the owner of record of the named property, or that the proposed work is authorized by the owner of record and that I have been authorized by the owner to make this application as his authorized agent and I agree to conform to all applicable laws of this jurisdiction. In addition, if a permit for work described in the application is issued, I certify that the code official's authorized representative shall have the authority to enter all areas covered by such permit at any reasonable hour to enforce the provision of the code(s) applicable to such permit.

SIGNATURE OF APPLICANT	ADDRESS	DATE	PHONE
RESPONSIBLE PERSON IN CHARGE OF WORK, TITLE		DATE	PHONE

BUILDING PERMIT INSPECTION PROCEDURES

Please call 874-8703 or 874-8693 (ONLY)

to schedule your inspections as agreed upon

Permits expire in 6 months, if the project is not started or ceases for 6 months.

The Owner or their designee is required to notify the inspections office for the following inspections and provide adequate notice. Notice must be called in 48-72 hours in advance in order to schedule an inspection:

By initializing at each inspection time, you are agreeing that you understand the inspection procedure and additional fees from a "Stop Work Order" and "Stop Work Order Release" will be incurred if the procedure is not followed as stated below.

A Pre-construction Meeting will take place upon receipt of your building permit.

 X **Framing/Rough Plumbing/Electrical: Prior to Any Insulating or drywalling**

 X **Final inspection required at completion of work.**

Certificate of Occupancy is not required for certain projects. Your inspector can advise you if your project requires a Certificate of Occupancy. All projects DO require a final inspection.

If any of the inspections do not occur, the project cannot go on to the next phase, REGARDLESS OF THE NOTICE OR CIRCUMSTANCES.

CERIFICATE OF OCCUPANICES MUST BE ISSUED AND PAID FOR, BEFORE THE SPACE MAY BE OCCUPIED.

Signature of Applicant/Designee

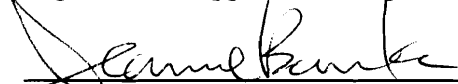

Signature of Inspections Official

Date

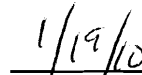

Date

City of Portland, Maine - Building or Use Permit

389 Congress Street, 04101 Tel: (207) 874-8703, Fax: (207) 874-8716

Permit No: 09-1386	Date Applied For: 12/07/2009	CBL: 037 A022001
------------------------------	--	----------------------------

Location of Construction: 25 FOREST AVE called "27"	Owner Name: PORTLAND STAGE COMPANY	Owner Address: PO BOX 1458	Phone:
Business Name: KATAHDIN	Contractor Name: Lebels Sheet Metal	Contractor Address: 221 Lincoln Street Lewiston	Phone (207) 212-4019
Lessee/Buyer's Name	Phone:	Permit Type: Hood Systems, Commerical	

Proposed Use: Commercial - "Kathahdin" restaurant - install hood system	Proposed Project Description: install hood system
---	---

Dept: Historic **Status:** Approved **Reviewer:** Scott Hanson **Approval Date:** 12/21/2009

Note: Left message on 12-14 for Paul Roy @ Lebel's Sheet Metal, informing him that I need a photo with the location of the proposed ductwork on the building marked or indicated. I also offered to meet on site to see the ocaation if that would be easier. **Ok to Issue:**

Requested information delivered on 12/21.

Dept: Zoning **Status:** Approved with Conditions **Reviewer:** Marge Schmuckal **Approval Date:** 12/07/2009

Note: **Ok to Issue:**

- 1) ANY exterior work requires a separate review and approval thru Historic Preservation. This property is located within an Historic District.
- 2) This property is located in a B-2c Zone which limits uses - no drinking establishments are allowed - full service meals are required to be eaten with knives and forks.
- 3) ANY exterior work requires a separate review and approval thru Historic Preservation. This property is located within an Historic District.
- 4) Separate permits shall be required for any new signage.

Dept: Building **Status:** Approved with Conditions **Reviewer:** Jeanine Bourke **Approval Date:** 01/19/2010

Note: **Ok to Issue:**

- 1) Approval of City license is subject to health inspections per the Food Code.
- 2) New cafe, restaurant, lounge, bar or retail establishment where food or drink is sold and/or prepared shall meet the requirements of the City and State Food Codes
- 3) Equipment must be installed in compliance per the manufacturer's specifications
- 4) The hood, duct and exhaust shall be installed per IMC 2003 and NFPA 96
This permit is approved based on the plans submitted and updated for reductions in the cleaances based on the application of a UL approved fire wrap or equivalent assembly per code.

Dept: Fire **Status:** Approved with Conditions **Reviewer:** Ben Wallace Jr. **Approval Date:** 01/19/2010

Note: **Ok to Issue:**

- 1) Hood suppression system shall be supervised by building fire alarm system.
- 2) Install shall comply with NFPA 96.
A compliance letter is required

Location of Construction: 25 FOREST AVE called "27"	Owner Name: PORTLAND STAGE COMPANY	Owner Address: PO BOX 1458	Phone:
Business Name: KATAHDIN	Contractor Name: Lebels Sheet Metal	Contractor Address: 221 Lincoln Street Lewiston	Phone (207) 212-4019
Lessee/Buyer's Name	Phone:	Permit Type: Hood Systems, Commerical	

Comments:

12/7/2009-mes: left a message with Becky requesting a copy of their menu - Since this is in a B-3c Zone, I want to be sure it is not just a bar use, but serves full menu items to be eaten with knives and forks.

1/15/2010-gg: This permit was misplaced, I located the permit. Jeanie will review the building today and we will give it to fire asap on Tuesday. I notified the applicant (Becky @ 838-4347) has been notified. /gg

1/19/2010-jmb: Left vcmmsg with Paul R. For floor plan showing where the hood and equipment is, the height above the hood and cleanouts. Paul left vcmmsg about 0 clearance wrap above hood and around duct. Ok to issue



Strengthening a Remarkable City, Building a Community for Life • www.portlandmaine.gov

Lee Urban - Director of Planning and Development
Jeanie Bourke - Inspection Division Services Director

Kitchen Exhaust System Checklist and code Provisions

Dear Applicant,

The following is a checklist to assist you in filing for a permit for a Kitchen Exhaust system. The applicable Mechanical Code provisions have also been attached. Please complete this and submit job specific construction documents that demonstrate compliance with the attached information.

Type of System:

Type I X Type II _____

Type I systems are systems that vent fryers, grills, broilers, ovens or woks.

Type II systems are systems that vent steamers and other non grease producing appliances.

Type of Materials:

Is the hood Stainless steel or other type of steel? Stainless Steel If Other, what Type? _____

Is the duct work Stainless steel or other type of steel? CARBON STEEL If Other, what type? _____

Thickness of the steel for the hood 18ga S/S

Thickness of the duct for the hood 16 ga steel

Type of Hood and Duct Supports

Captive Wire Back shell Hood
as per specs

Type of seams and Joints All welded

Grease Gutters provided? Yes

Hood Clearance reduction to Combustibles design /specs:

Yes As per drawings

Duct Clearance reduction to Combustibles design /specs:

Yes As per drawings

Vibration Isolation System:

Air Velocity within the duct system 1500 RPM

Grease accumulation prevention system:

No Per Capture Aire spec.

Cleanouts _____

Grease Duct enclosure Fire master zero Clearance

Exhaust Termination Roof X Wall _____

Fire Suppression System Yes

Exhaust fan mounting and clearance from the roof / wall or Combustibles:

Duct Run up along outside of brick Building

Exhaust fan distance from property lines _____

Exhaust fan distance from other vents or openings _____

Exhaust fan distance from adjacent buildings _____

Exhaust fan height above adjoining grade _____

Hood Specs

Style of Hood Back shelf Capture Aire

Type of Filter Baffle Type

Height of filter above nearest cooking surface 35-47"

Capacity of hood CFM 3300

Make up Air system description and capacity

None

dust work - 16 ga All welded
Fire wrap all interior ductwork.

Block
As per specs
Capture Area

(AA)

Stack noise
up along build up
Above Roof Line
(2 Floor)
All well duct

customer installed
metal stud wall

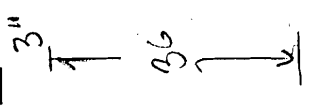

bid exterior
building

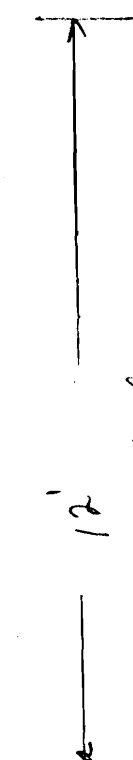

Backshelving hood
as per drawings (capture Area)

Per Perimeter
of ceiling

STABBIN REST.
101st Ave
PORTLAND ME
Contractor: Lebel's Sheet Metal
Contact: PAUL ROY
Tel: 607-782-2235
Cell: 576-1862

(AA)

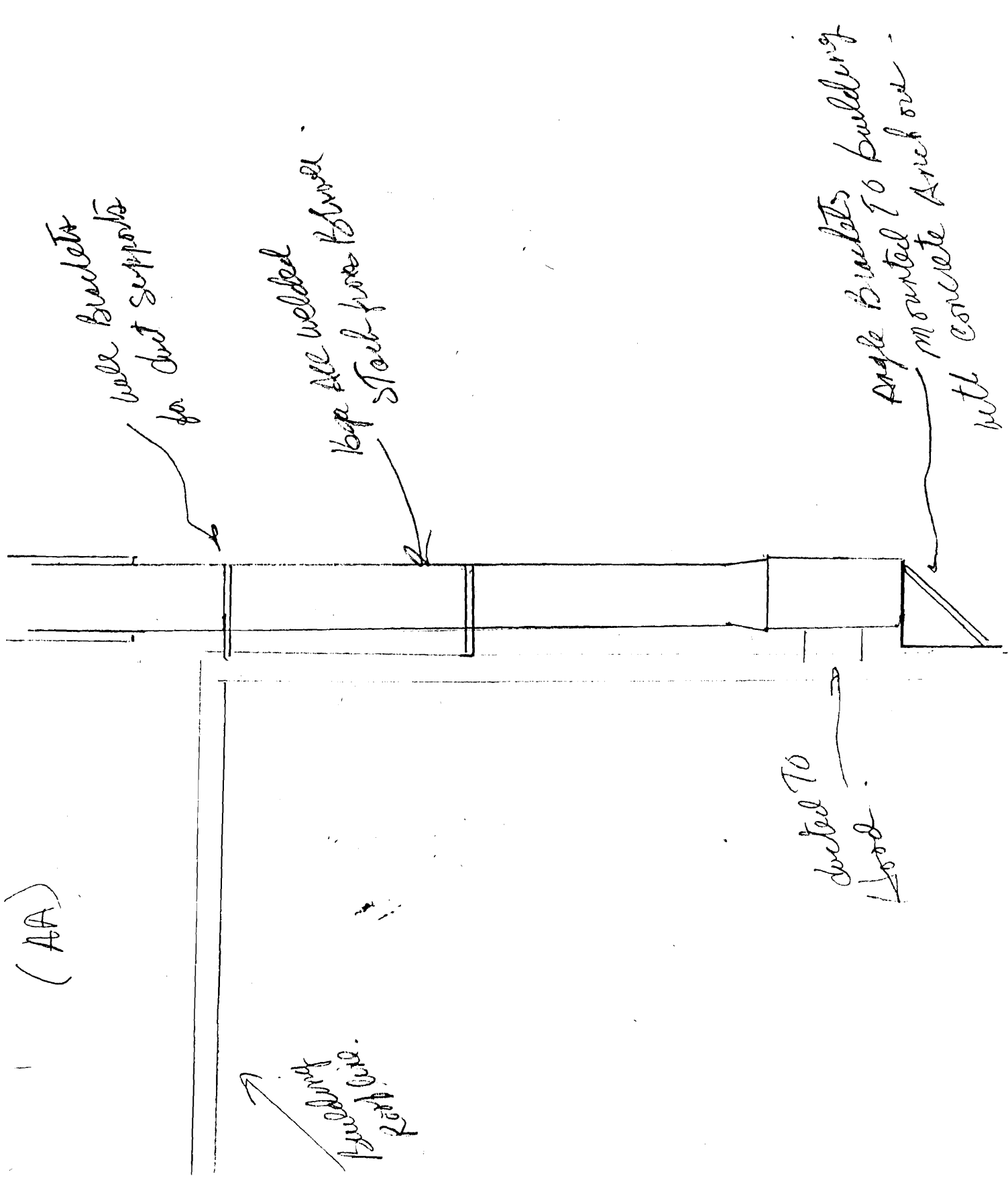

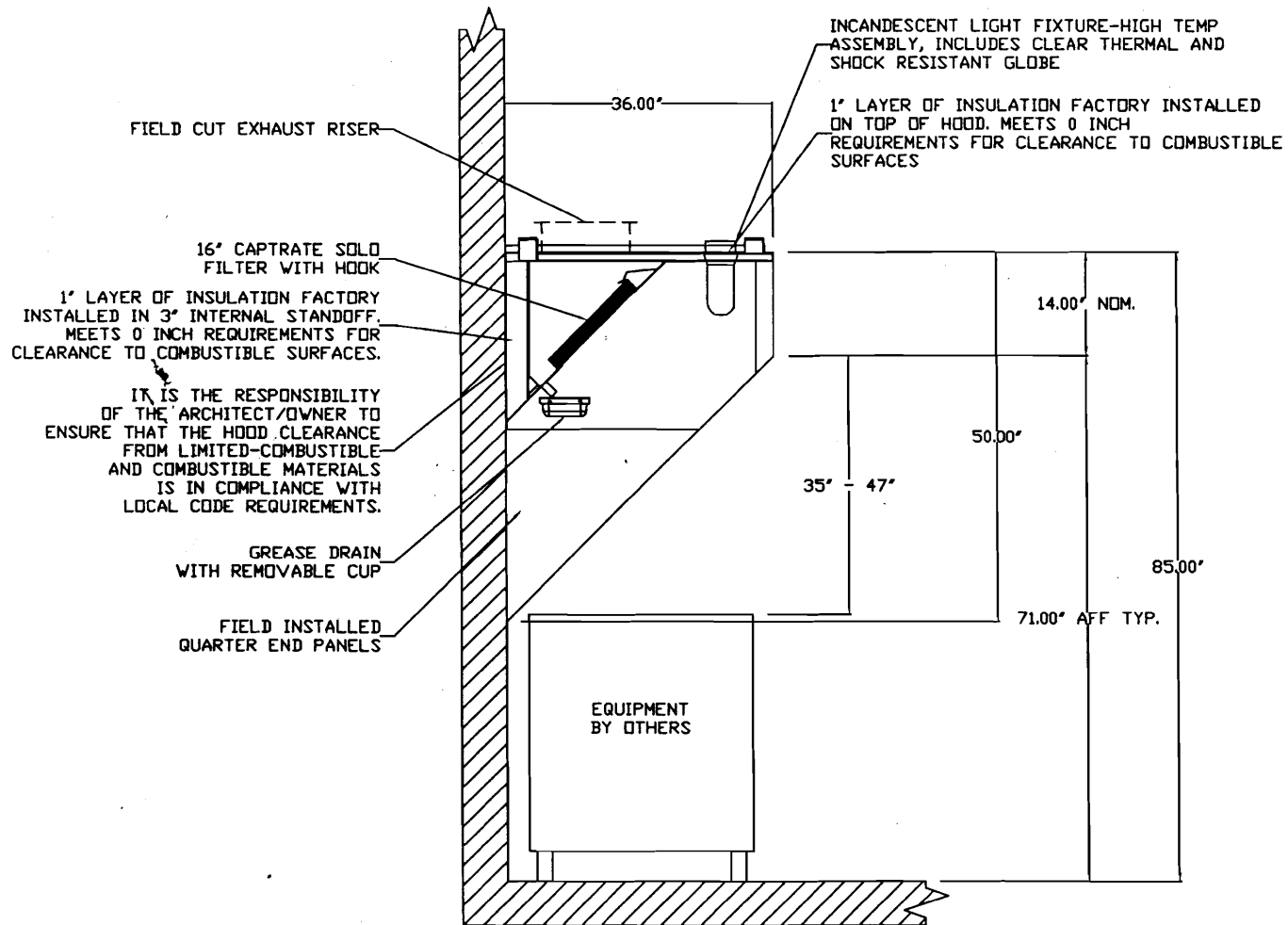

16" CAPTRATE SOLID FILTER WITH HOOK
 1" LAYER OF INSULATION FACTORY INSTALLED IN 3" INTERNAL STANDOFF. MEETS 0 INCH REQUIREMENTS FOR CLEARANCE TO COMBUSTIBLE SURFACES.

IT IS THE RESPONSIBILITY OF THE ARCHITECT/OWNER TO ENSURE THAT THE HOOD CLEARANCE FROM LIMITED-COMBUSTIBLE AND COMBUSTIBLE MATERIALS IS IN COMPLIANCE WITH LOCAL CODE REQUIREMENTS.

GREASE DRAIN WITH REMOVABLE CUP

FIELD INSTALLED QUARTER END PANELS

INCANDESCENT LIGHT FIXTURE-HIGH TEMP ASSEMBLY, INCLUDES CLEAR THERMAL AND SHOCK RESISTANT GLOBE

1" LAYER OF INSULATION FACTORY INSTALLED ON TOP OF HOOD. MEETS 0 INCH REQUIREMENTS FOR CLEARANCE TO COMBUSTIBLE SURFACES

14.00" NOM.

50.00"

35" - 47"

85.00"

71.00" AFF TYP.

SECTION VIEW - MODEL 3650BD-2

NOTE: HOOD MUST OVERHANG FRONT OF APPLIANCES BY A MINIMUM OF 3"

CUSTOMER APPROVAL TO MANUFACTURE:

Approved as Noted

Approved with NO Exception Taken

Revise and Resubmit

SIGNATURE _____

Your Title _____ Date _____

CAPTIVE AIR

JOB Becky Job	
LOCATION Portland, ME	
DATE 11/24/2009	JOB # 1061587
DWG # BeckyJob	DRAWN BY BFC
REV. 1.00	SCALE 8.5' x 11'

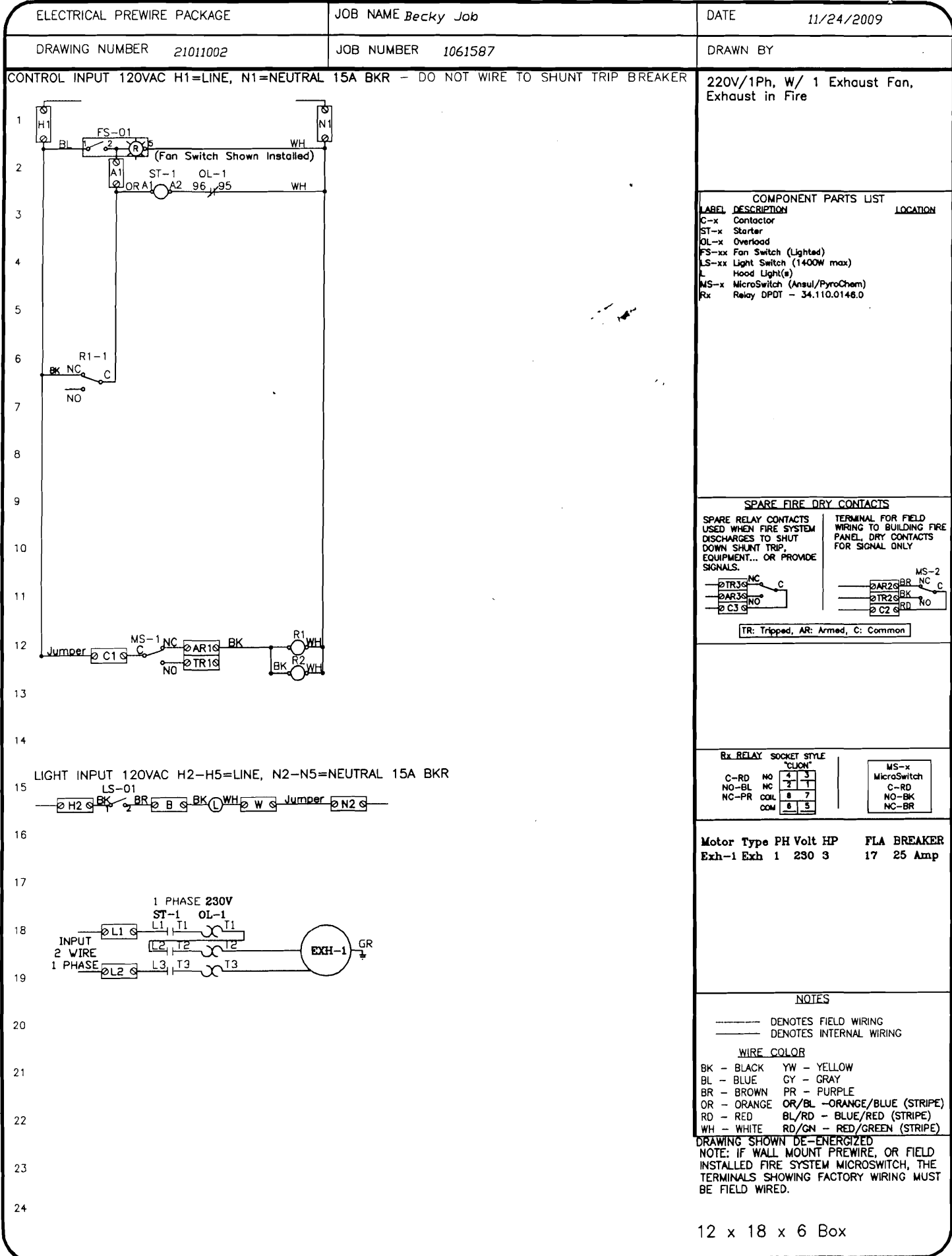

ELECTRICAL PREWIRE PACKAGE

JOB NAME *Becky Job*

DATE *11/24/2009*

DRAWING NUMBER *21011002*

JOB NUMBER *1061587*

DRAWN BY

CONTROL INPUT 120VAC H1=LINE, N1=NEUTRAL 15A BKR - DO NOT WIRE TO SHUNT TRIP BREAKER

220V/1Ph, W/ 1 Exhaust Fan, Exhaust in Fire

COMPONENT PARTS LIST

LABEL	DESCRIPTION	LOCATION
C-x	Contact	
ST-x	Starter	
OL-x	Overload	
FS-xx	Fan Switch (Lighted)	
LS-xx	Light Switch (1400W max)	
L	Hood Light(s)	
MS-x	MicroSwitch (Anaul/PyroChem)	
Rx	Relay DPDT - 34.110.0146.0	

SPARE FIRE DRY CONTACTS

SPARE RELAY CONTACTS USED WHEN FIRE SYSTEM DISCHARGES TO SHUT DOWN SHUNT TRIP, EQUIPMENT... OR PROVIDE SIGNALS.

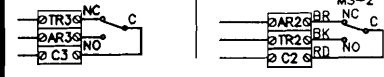

TR: Tripped, AR: Armed, C: Common

LIGHT INPUT 120VAC H2-H5=LINE, N2-N5=NEUTRAL 15A BKR



Rx RELAY SOCKET STYLE "CJON"

C-RD	NO	4	3
NO-BL	NC	2	1
NC-PR	COM	8	7
		6	5

MS-x MicroSwitch

C-RD
NO-BK
NC-BR

Motor Type PH Volt HP FLA BREAKER

Exh-1	Exh 1	230	3	17	25 Amp
-------	-------	-----	---	----	--------

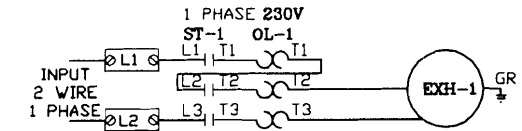

NOTES

- DENOTES FIELD WIRING
 - _____ DENOTES INTERNAL WIRING
- WIRE COLOR
- BK - BLACK
 - BL - BLUE
 - BR - BROWN
 - OR - ORANGE
 - RD - RED
 - WH - WHITE
 - YW - YELLOW
 - CY - GRAY
 - PR - PURPLE
 - OR/BL - ORANGE/BLUE (STRIPE)
 - RD/BL - BLUE/RED (STRIPE)
 - RD/GN - RED/GREEN (STRIPE)

DRAWING SHOWN DE-ENERGIZED
NOTE: IF WALL MOUNT PREWIRE, OR FIELD INSTALLED FIRE SYSTEM MICROSWITCH, THE TERMINALS SHOWING FACTORY WIRING MUST BE FIELD WIRED.

12 x 18 x 6 Box

ELECTRICAL PACKAGES

NO.	TAG	PACKAGE #	LOCATION	SWITCHES		ROOFTOP STARTERS	OPTION	FANS CONTROLLED				
				LOCATION	QUANTITY			TYPE	Ø	H.P.	VOLT	FLA
1		21011002	Wall Mount In SS Box	SS Wall Mount Box	1 Light 1 Fan		Exhaust In Fire	Exhaust	1	3.000	230	17.0

DETAIL OF REMOTE S/S BOX

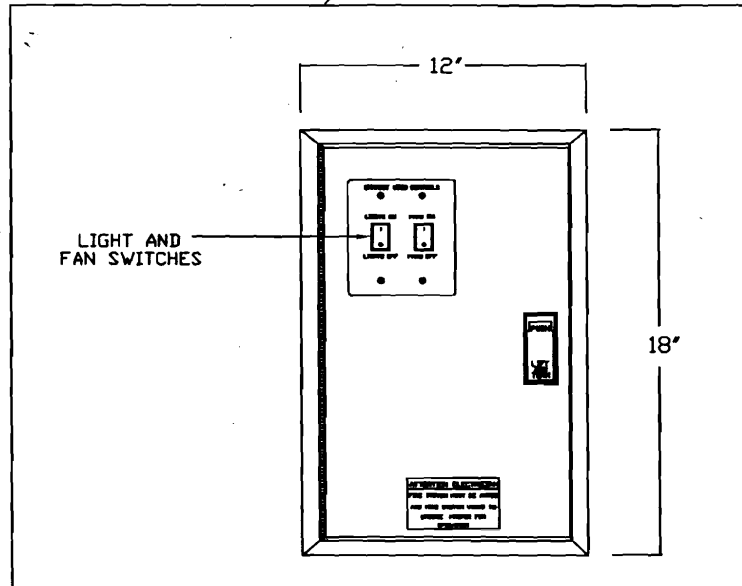

CUSTOMER APPROVAL TO MANUFACTURE:

- Approved as Noted
- Approved with NO Exception Taken
- Revise and Resubmit

SIGNATURE _____
 Your Title _____ Date _____



JOB Becky Job	
LOCATION Portland, ME	
DATE 11/24/2009	JOB # 1061587
DWG # Becky Job	DRAWN BY BFC
REV. 1.00	SCALE 8.5' x 11'

FAN #1 BI20CARM - EXHAUST FAN

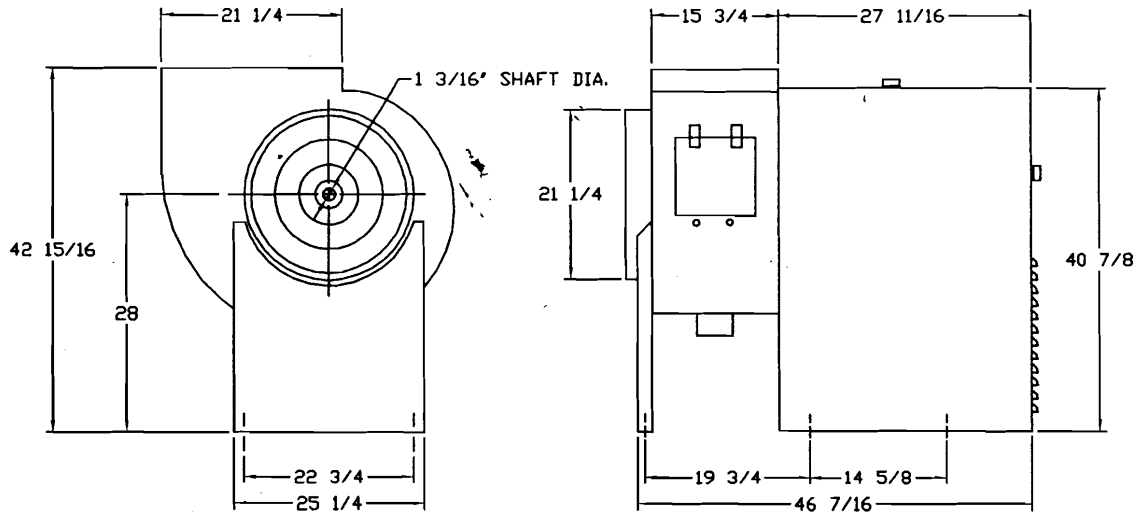

FEATURES:

- FULL AMCA CLASS 1 OPERATION
- VENTED MOTOR COVER FOR WEATHER PROTECTION
- UL762 LISTED FOR RESTAURANT DUTY
- UPBLAST DISCHARGE DIRECTS AIR AWAY FROM FLOOR
- CONTINUOUSLY WELDED HOUSING
- CLEANOUT DOOR WITH LATCHES PROVIDE EASY ACCESS WITHOUT TOOLS
- 2" GREASE DRAIN WILL NOT CLOG

OPTIONS

- EXHAUST FAN GREASE CUP (UTILITY SET)
- EXTRA SET OF BELTS
- RUBBER VIBRATION ISOLATORS FOR BI UTILITY SETS (SET OF 6)

CUSTOMER APPROVAL TO MANUFACTURE:

Approved as Noted

Approved with NO Exception Taken

Revise and Resubmit

SIGNATURE _____

Your Title _____ Date: _____



JOB Becky Job	
LOCATION Portland, ME	
DATE 11/24/2009	JOB # 1061587
DWG # BeckyJob	DRAWN BY BFC
REV. 1.00	SCALE 8.5' x 11'

EXHAUST FAN INFORMATION

FAN UNIT NO.	FAN UNIT MODEL #	MODEL	TAG	CFM	S.P.	RPM	H.P.	Ø	VOLT	FLA	DISCHARGE VELOCITY	WEIGHT (LBS.)
1	BI20CARM	BI20CARM		3300	3.000	1459	3.000	1	230	17.0	1420 FPM	441.80

FAN OPTIONS

FAN UNIT NO.	OPTION (Qty. - Descr.)
1	1 - Exhaust Fan Grease Cup (Utility Set)
	1 - Extra Set of Belts
	1 - Rubber Vibration Isolators for BI Utility Sets (set of 6)

FAN ACCESSORIES

FAN UNIT NO.	FAN UNIT TAG	EXHAUST			SUPPLY			
		GREASE CUP	GRAVITY DAMPER	WALL MOUNT	SIDE DISCHARGE	GRAVITY DAMPER	MOTORIZED DAMPER	WALL MOUNT
1		YES						

CUSTOMER APPROVAL TO MANUFACTURE:

Approved as Noted
 Approved with NO Exception Taken
 Revise and Resubmit
 SIGNATURE _____
 Your Title _____ Date _____



JOB Becky Job	
LOCATION Portland, ME	
DATE 11/24/2009	JOB # 1061587
DWG # BeckyJob	DRAWN BY BFC
REV. 1.00	SCALE 8.5' x 11'

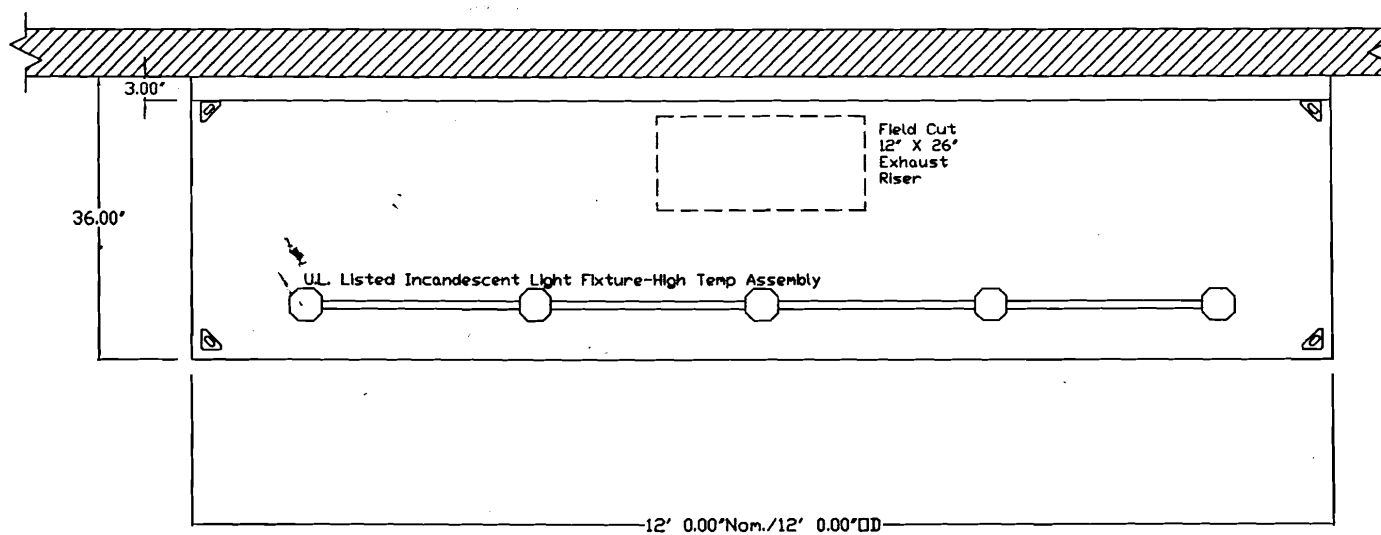

PLAN VIEW - Hood #1
 12' 0.00" LONG 3650BD-2

CUSTOMER APPROVAL TO MANUFACTURE:

- Approved as Noted
- Approved with NO Exception Taken
- Revise and Resubmit

SIGNATURE _____
 Your Title _____ Date _____



JOB Becky Job	
LOCATION Portland, ME	
DATE 11/24/2009	JOB # 1061587
DWG # BeckyJob	DRAWN BY BFC
REV. 1.00	SCALE 8.5' x 11'

HOOD INFORMATION

HOOD NO.	MODEL	LENGTH	MAX. COOKING TEMP.	EXHAUST PLENUM RISER(S)					SUPPLY PLENUM RISER(S)					HOOD CONSTRUCTION	HOOD CONFIG.		
				TOTAL EXH. CFM	WIDTH	LENG.	DIA.	CFM	S.P.	TOTAL SUP. CFM	WIDTH	LENG.	DIA.		CFM	S.P.	END TO END
1	3650 BD-2	12' 0.00'	700 Deg.	3300	12'	26'		3300	-1.638'	0					430 SS Where Exposed	ALONE	ALONE

HOOD INFORMATION

HOOD NO.	FILTER(S)			LIGHT(S)			UTILITY CABINET(S)					FIRE SYSTEM PIPING	HOOD WEIGHT		
	TYPE	QTY.	HEIGHT	LENGTH	QTY.	TYPE	WIRE GUARD	LOCATION	FIRE SYSTEM		ELECTRICAL			SWITCHES	
									TYPE	SIZE	MODEL #	QUANTITY	LOCATION		
1	Captrate Solo Filter w/	4	16"	16"	5	Incandescent Light Fixt	NO							NO	645 LBS

HOOD OPTIONS

HOOD NO.	OPTION
1	INSULATION FOR BACK STANDOFF
	TOP INSULATION

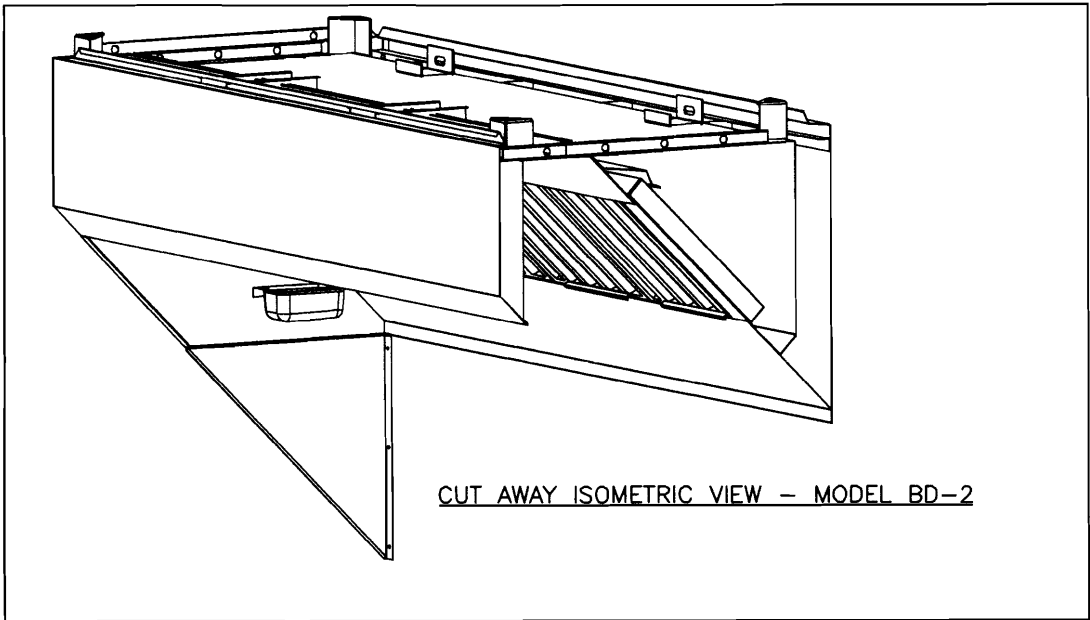

CUT AWAY ISOMETRIC VIEW - MODEL BD-2

CUSTOMER APPROVAL TO MANUFACTURE:

Approved as Noted
 Approved with NO Exception Taken
 Revise and Resubmit
 SIGNATURE _____
 Your Title _____ Date _____



JOB Becky Job	
LOCATION Portland, ME	
DATE 11/24/2009	JOB # 1061587
DWG # BeckyJob	DRAWN BY BFC
REV. 1.00	SCALE 8.5' x 11'

LICENSE INSPECTION SLIP

Applicant: Big Pig, Inc.
Business Name: Katahdin
Address: 27 Forest Avenue
Phone : 838-4347
Type of License: Class I Restaurant With Liquor
Occupancy: Entertainment: No
Amusements: NO Pool Tables: NO

NEW LOCATION
Date Issued: 11-19-09
Date of Application: 11-19-09
Comments: Council Meeting 12-7-09. Formerly Geo's Patisserie
CBL: 037 A 022
Outdoor Dining: NO

Contact: Becky Lee Simmons, 838-4347

ZONING: [checked] Approved [] Denied Zone B-3c
CHANGE OF USE PERMIT [checked] Not Required [] Required Issue Date

12/3/09
Date

[Signature]
Signature of Zoning Enforcement Official

Comments: Assessor's address is 25 Forest for property. B-3c zone does not allow just bars - must serve full meal

INSPECTION Services: [] Approved [] Conditional Approval [] Denied

Date Signature of Inspector

Date Signature of Chief or Asst. Chief of Inspection

Comments: State License Posted

FIRE Prevention Bureau: [] Approved [] Conditional Approval [] Denied

Date Signature of Inspector

Comments: PLEASE RECORD OCCUPANCY LIMITS and let me know if there is outdoor dining.

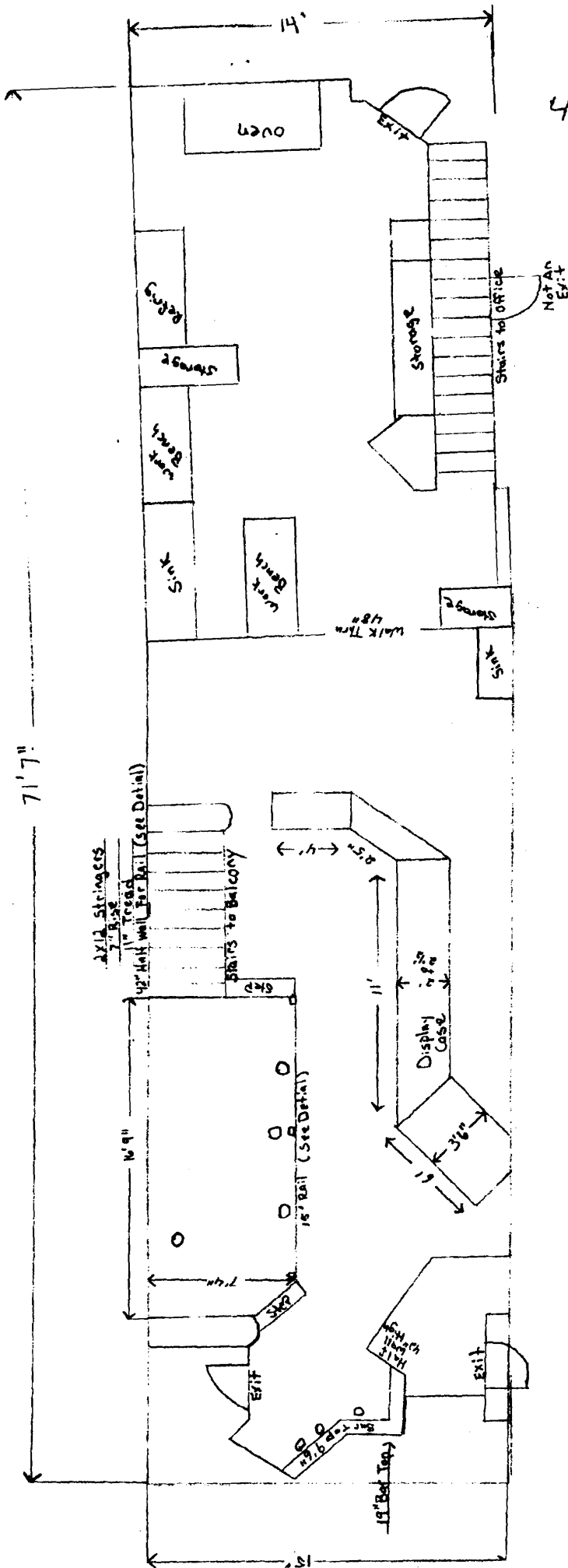

4 Tables on stage
 2'6" Between Tables
 3 chairs at Bar Top
 Next to Door

OLD -
 CREPâtisserie

over 9 seats
 considered a
 restaurant

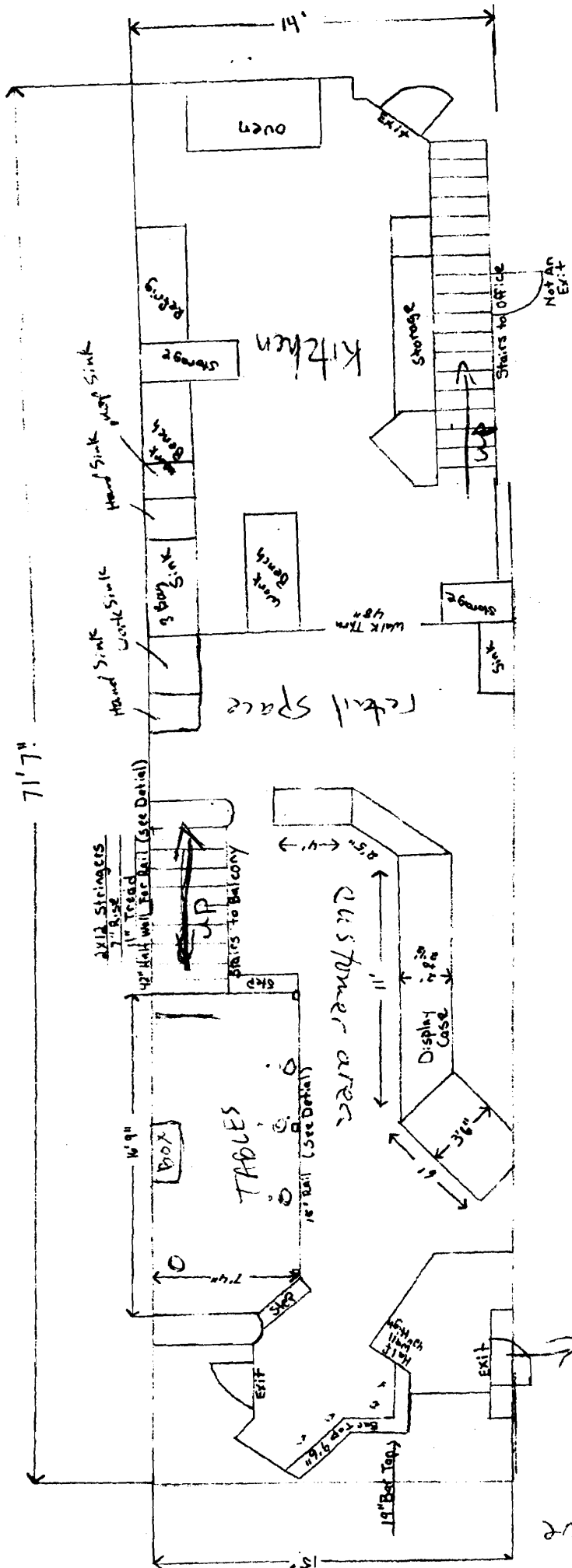

OLD
Greer's Pat. Issued

Franching of Forest Ave
 out to Road
 Into Theatre

Dimensions
60' x 100'
10' x 10' Foot

* TABLES

* 7 NEW WALLS 2X4 CONSTRUCTION
16" ON CENTER WITH NEW SHEATH

* (1) NEW 3'-0" x 7'-0" DOOR

PATISSONNE
Cakes
(C/L/D)

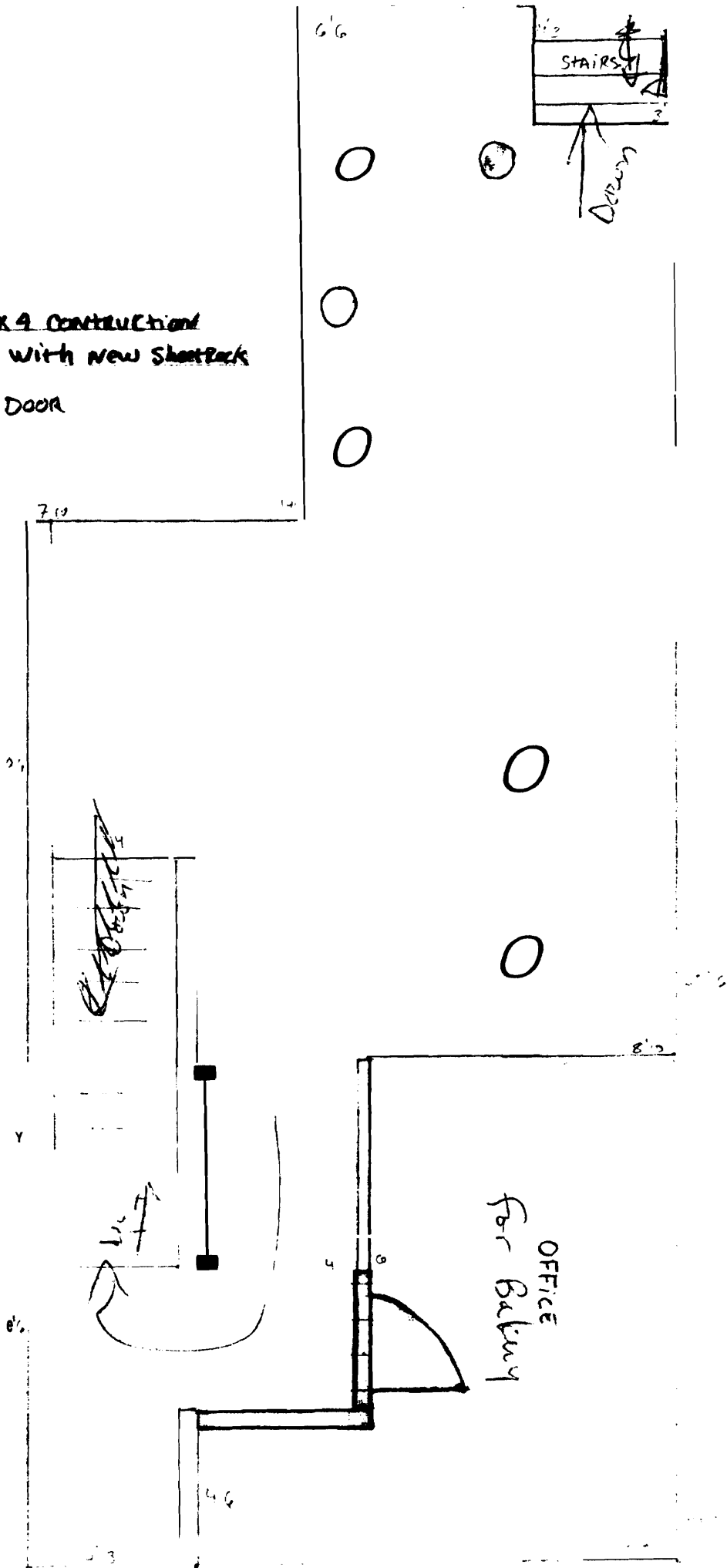

42" Above
ROOF

Kelahan's Rest
Pine Log / Lebel's Street Metal
576-1863

6' 0" 1/2"
← All well done
2011-12

REMOVE EXISTING DOOR

14/12/2019







14/12/2009





14/12/2009