

LANDSCAPE NOTES

GENERAL:

1. SAVE EXISTING TREES AS SHOWN. DO NOT CUT OR CLEAR ANY VEGETATION BEYOND THE IMPACT LIMIT LINE.
2. ALL PLANT MATERIALS INSTALLED ARE TO MEET THE SPECIFICATIONS OF THE "AMERICAN STANDARDS FOR NURSERY STOCK" BY THE AMERICAN ASSOCIATION OF NURSERMEN.
3. ALL PROPOSED PLANT LOCATIONS SHALL BE AS SHOWN ON PLANS. CONTRACTOR SHALL VERIFY LOCATION OF ALL UTILITIES PRIOR TO PLANTING AND WILL NOTIFY OWNER'S REPRESENTATIVE IN THE EVENT OF CONFLICTS.
4. PLANT LOCATIONS ARE TO BE SCALED FROM THE LANDSCAPE PLAN UNLESS NOTED OTHERWISE.
5. NO PLANT MATERIAL SHALL BE INSTALLED UNTIL FINAL GRADING AND CONSTRUCTION HAS BEEN COMPLETED IN THE IMMEDIATE AREA.
6. FINAL QUANTITY FOR EACH PLANT TYPE IS NOTED IN THE PLANT LIST. THIS NUMBER SHALL TAKE PRECEDENCE IN THE CASE OF ANY DISCREPANCY BETWEEN QUANTITIES SHOWN IN THE LIST AND ON THE PLAN.
7. ANY PROPOSED SUBSTITUTIONS MUST BE APPROVED BY THE OWNER OR THE OWNER'S REPRESENTATIVE.
8. ALL DISTURBED AREAS TO BE LOAMED AND SEEDDED.

MAINTENANCE:

1. LAWNS: SHALL BE WATERED, FERTILIZED AND MOUN ON A REGULAR BASIS ACCORDING TO SEASON AND RAINFALL, TO PRODUCE A STRONG TURF OF 80% MIN. COVERAGE WITHIN THE FIRST YEAR, FREE FROM SIZABLE THIN OR BARE SPOTS. REGRADING AND RESEEDING WILL BE PERFORMED ON BARE SPOTS UNTIL COVERAGE IS COMPLETE.
2. TREES & SHRUBS: THE ESTABLISHMENT PERIOD SHALL BE TWO CALENDAR YEARS FROM THE DATE OF FINAL ACCEPTANCE. DURING THE ESTABLISHMENT PERIOD THE OWNER OR OWNER'S CONTRACTOR SHALL WATER, CULTIVATE AND PRUNE AS REQUIRED TO MAINTAIN A HEALTHY GROWING CONDITION.
3. AT THE END OF THE ESTABLISHMENT PERIOD AND UPON SUBSEQUENT ANNUAL INSPECTIONS, PLANTS WHICH HAVE DIED OR FAILED TO THRIVE SHALL BE REPLACED WITH EQUIVALENT SIZE AND SPECIES. AFTER THE CONTRACTOR'S GUARANTEE PERIOD HAS ENDED, IT IS THE OWNER'S RESPONSIBILITY TO MAINTAIN AND REPLACE PLANTINGS.
4. TREES, SHRUBS AND LAWNS WHICH ARE NOT IRRIGATED WITH AN AUTOMATIC SPRINKLER OR DRIP SYSTEM SHALL BE THOROUGHLY WATERED ON A REGULAR BASIS DURING PERIODS OF BELOW AVERAGE RAINFALL. SOIL SHOULD BE SAMPLED AT A DEPTH OF 12" AND IF DRY, WATER TO DEPTH OF 24".
5. MULCH IS TO BE MAINTAINED AT A DEPTH TO COMPLETELY COVER THE SOIL AND TO PRESERVE MOISTURE AND MINIMIZE WEEDS.
6. TREES, SHRUBS AND LAWNS SHALL BE FERTILIZED ANNUALLY AND TREATED WITH INSECTICIDES AND/OR FUNGICIDES AS REQUIRED FOR CONTINUED HEALTHY GROWTH.
7. SUCKERS, WEEDS, AND DEAD WOOD SHALL BE REMOVED ON A SEASONAL BASIS, AND SHRUBS SHALL BE PRUNED TWICE A YEAR ACCORDING TO THE REQUIREMENTS OF EACH SPECIES (IE. SOME SPECIES SHOULD NOT BE PRUNED AT ALL). SHRUBS SHALL NOT BE PRUNED INTO INDIVIDUALS BUT ALLOWED TO GROW INTO A MASS.
8. WHERE TREES ARE LOCATED NEAR SIDEWALKS OR PARKING LOTS, THE CANOPY SHALL BE LIMBED UP TO PROMOTE SAFE CLEARANCE TO 8' ABOVE GRADE.
9. LAWN AREAS SHALL BE MOUN AS OFTEN AS NECESSARY TO KEEP LAWNS TO A 2 1/2 - 3" HEIGHT, AND AERATED ON A SEASONAL BASIS.
10. BEDS AND LAWN EDGES SHALL BE REGULARLY TRIMMED AND EDGED.
11. PERENNIAL AND ANNUAL BEDS SHALL BE DESIGNED, PLANTED AND MAINTAINED FOR SEASONAL COLOR AND INTEREST. ANNUALS MAY BE INCORPORATED TO A MAXIMUM LIMIT OF 25% OF THE BED AREA OF MAINTAINED BEDS FROM MAY 15 THROUGH NOVEMBER 15. PERENNIAL BEDS SHALL BE WATERED AS REQUIRED FOR HEALTHY PLANT GROWTH, AND WEEDED AND DEADHEADED ON A MONTHLY BASIS.

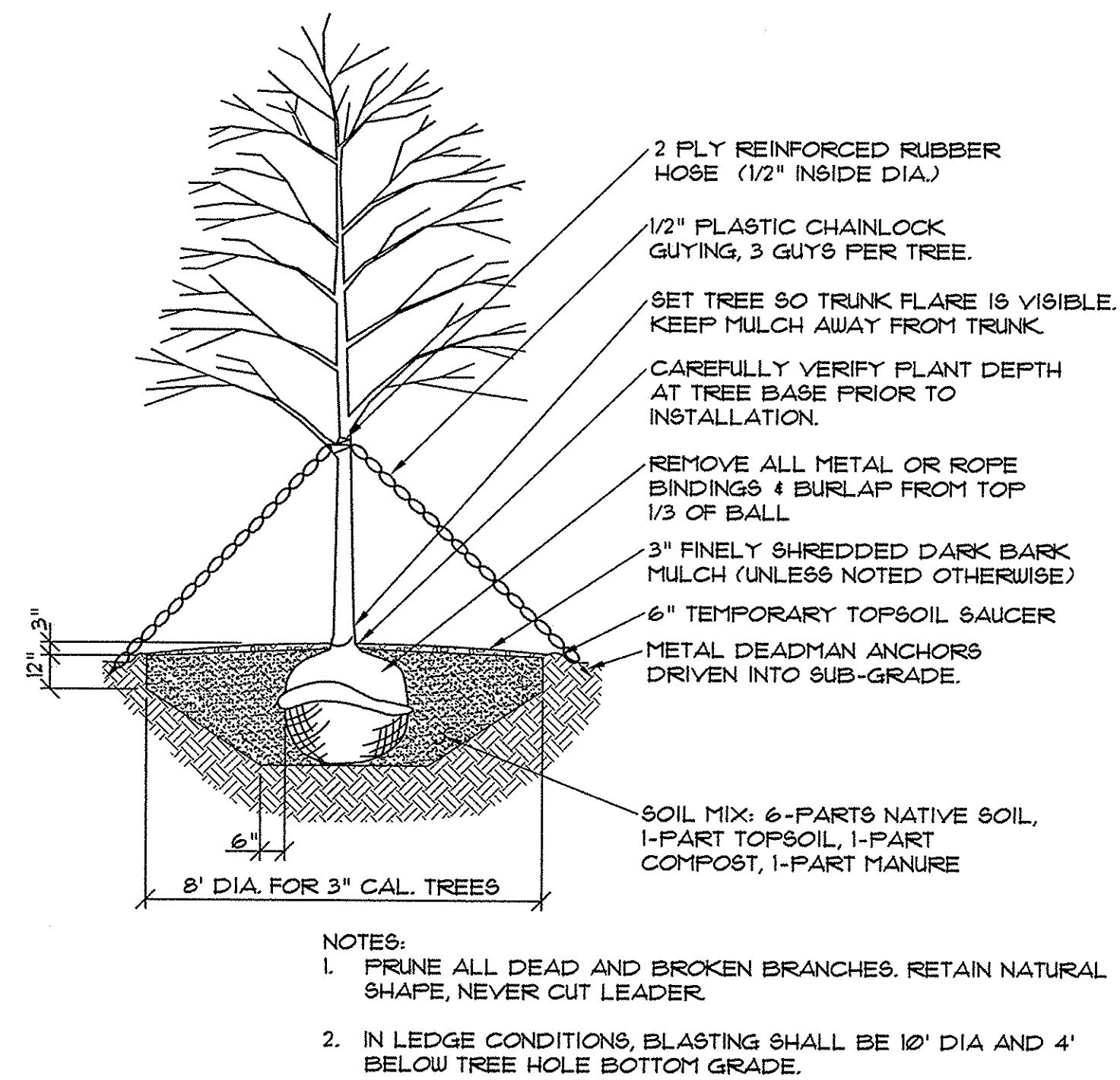

2 DECIDUOUS TREE PLANTING DETAIL

NOT TO SCALE

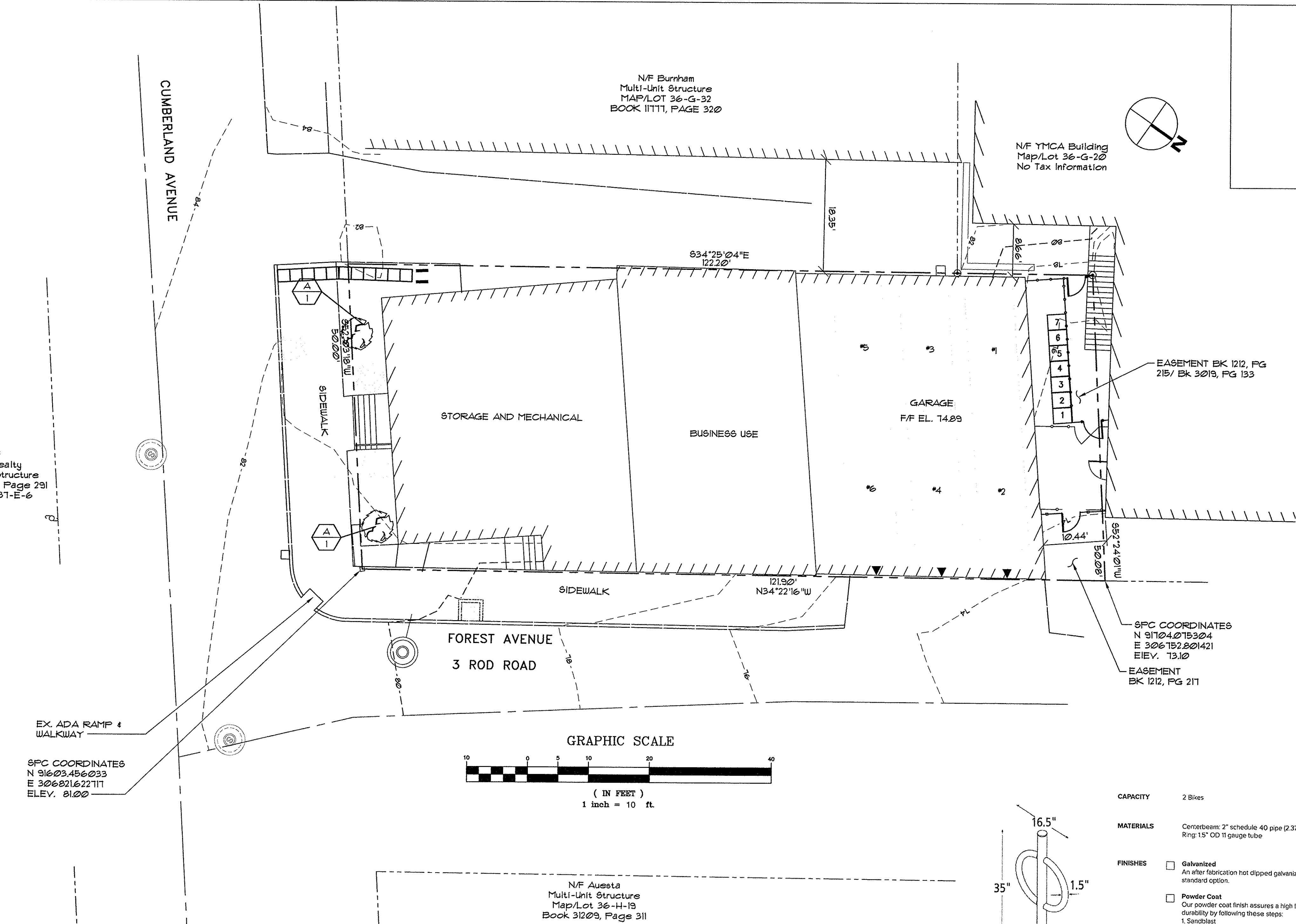

PLANT LIST

SYMBOL	COMMON NAME/BOTANICAL NAME	SIZE	QUANTITY	ROOT	NOTES
A	Hophornbeam / <i>Ostrya Virginiana</i>	2 1/2" Cal.	2	B#B	

LEGEND

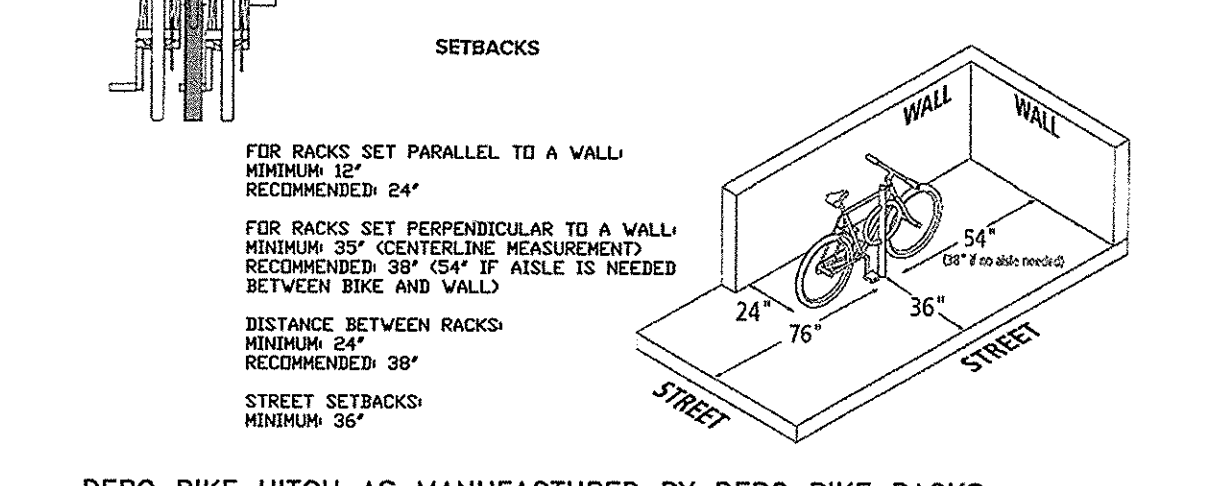
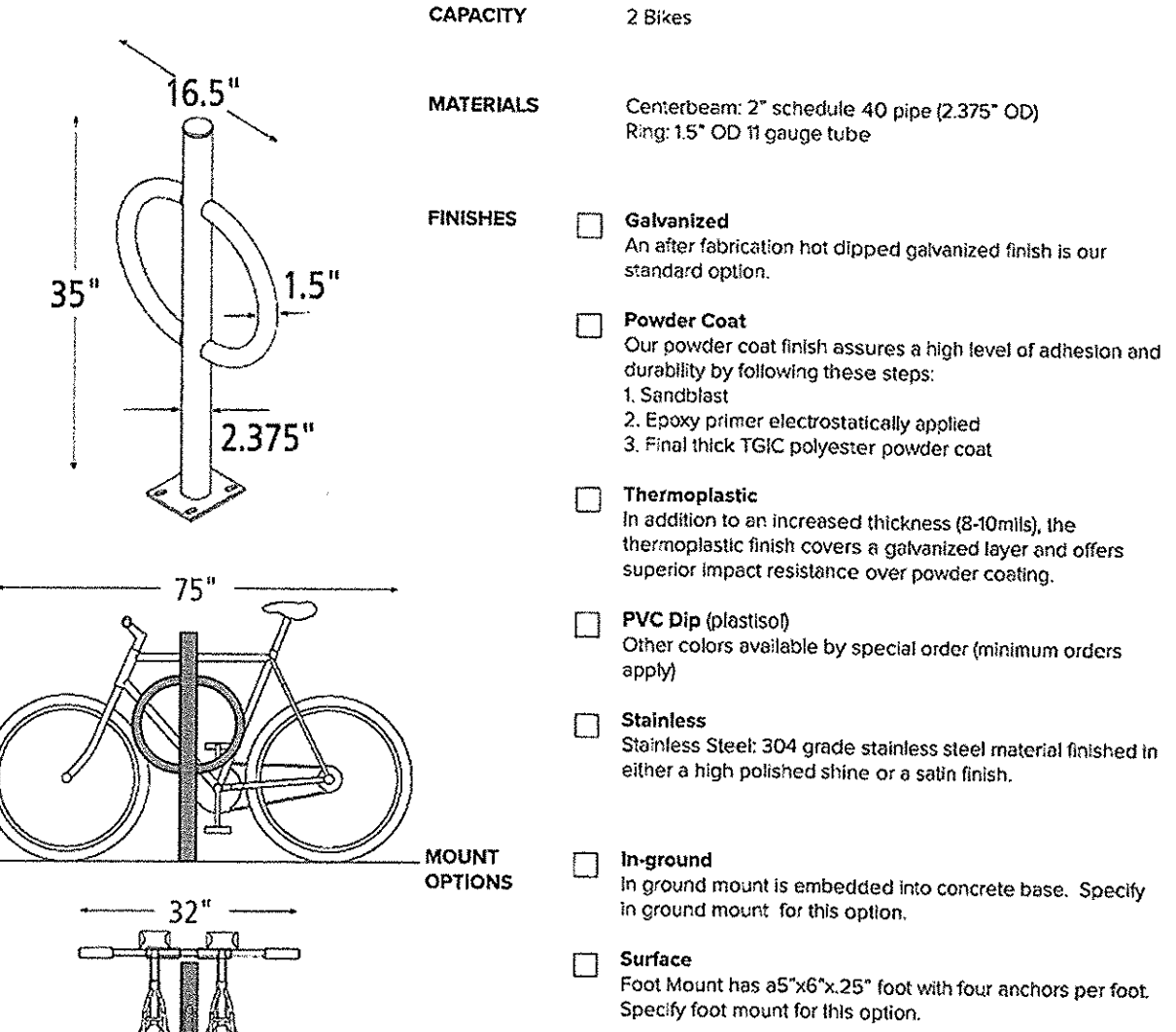
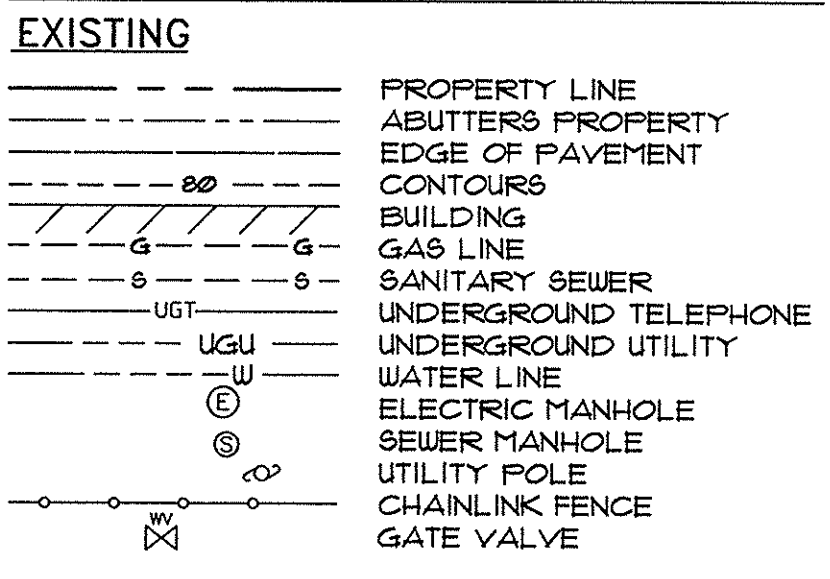

DERO BIKE HITCH AS MANUFACTURED BY DERO BIKE RACKS

1 BICYCLE RACK SPECIFICATION - BIKE HITCH (1-33a)

NOT TO SCALE

WALSH
ENGINEERING ASSOCIATES, INC.

One Karen Dr., Suite 2A | Westbrook, Maine 04092
ph: 207.553.9898 | www.walsh-eng.com

Copyright © 2018

STATE OF MAINE
THOMAS S. GREER
No. 4206
LICENSED PROFESSIONAL ENGINEER

415 CUMBERLAND AVENUE
PORTLAND, MAINE

415 CA, LLC
25 EDGEHILL ROAD
BROOKLINE, MA 02445

415 CUMBERLAND AVENUE
PORTLAND, MAINE

415 CUMBERLAND AVENUE
PORTLAND, MAINE

415 CUMBERLAND AVENUE
PORTLAND, MAINE

Rev.	Date	Description	Drawn	Check

LANDSCAPE PLAN & NOTES

Job No.: 17164 Sheet No.:
Date: 1/16/18
Scale: AS SHOWN
Drawn: RS
Checked: TSL

C1.2