

NOTES:

- 1. NO EXTERIOR DOOR WORK.
- 2. NO WINDOW WORK.

KEY:

1. PARTITION TYPE:

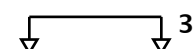

2. NEW WALL:

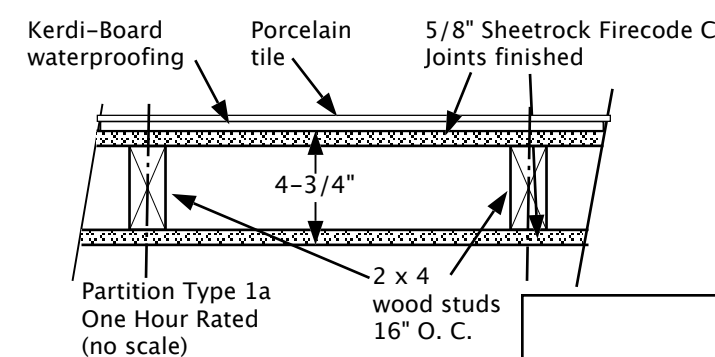
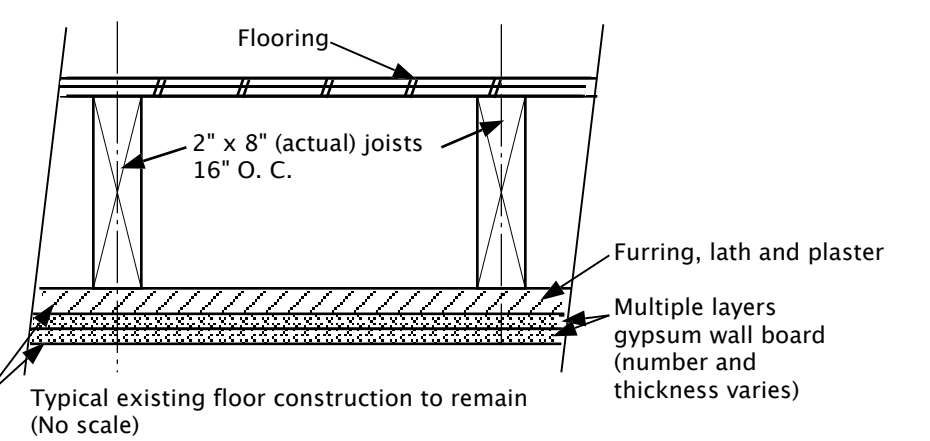
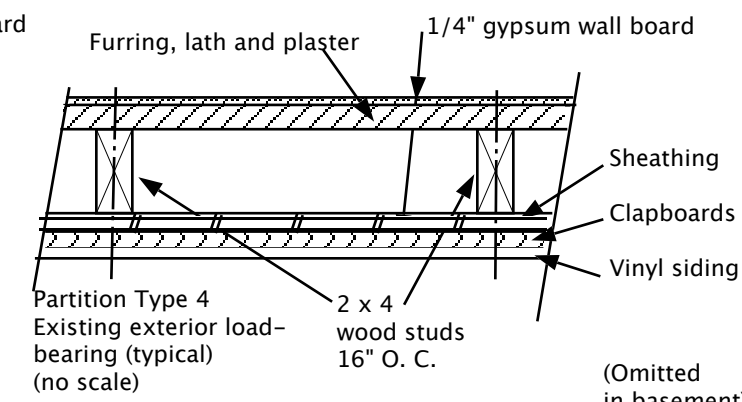
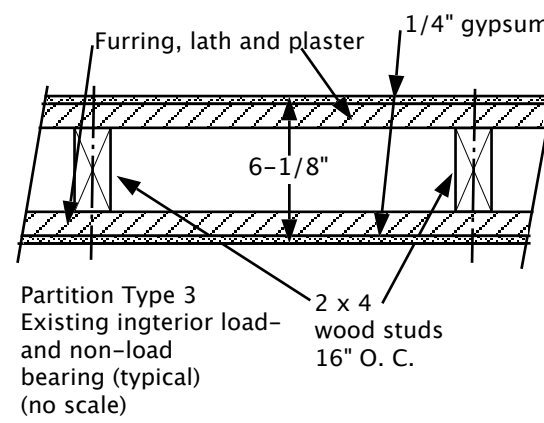
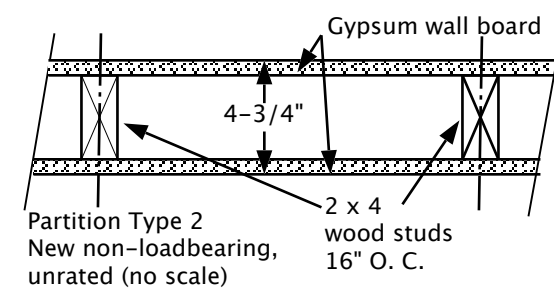
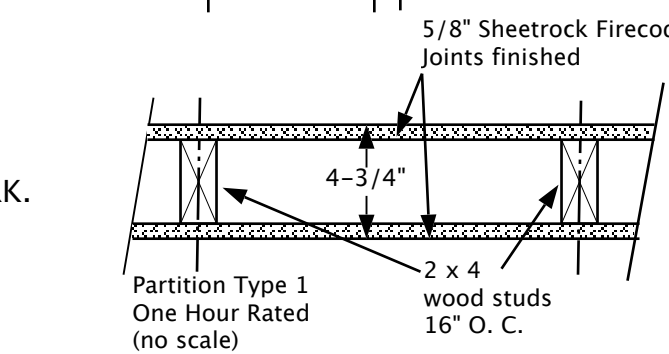

**5 Sherman Street
Portland ME 04101**

Owner: Elise & Stephen Smith
13 Deering St
Portland ME 04101

Tel: 207.332.9588
stephen.donnsmith1@gmail.com

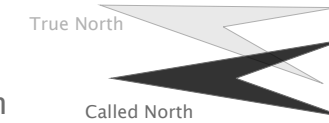

Proposed Plan Lvl 1
1/4" = 1' - 0"
Rev 2 - 08.10.2017

A-1

