

**NOTES:**

- 1. NO EXTERIOR DOOR WORK.
- 2. NO WINDOW WORK.

**KEY:**

1. PARTITION TYPE:

2. NEW WALL:

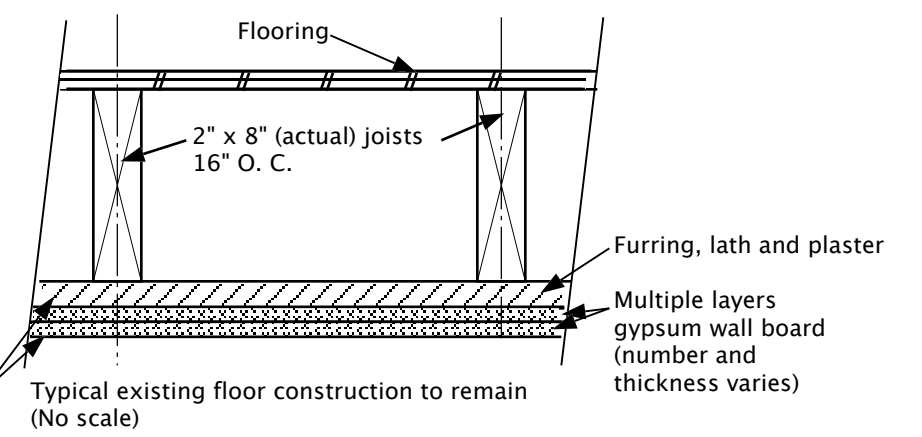
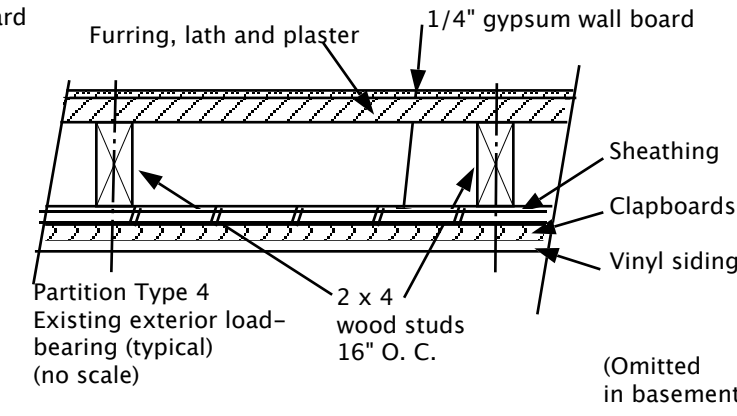
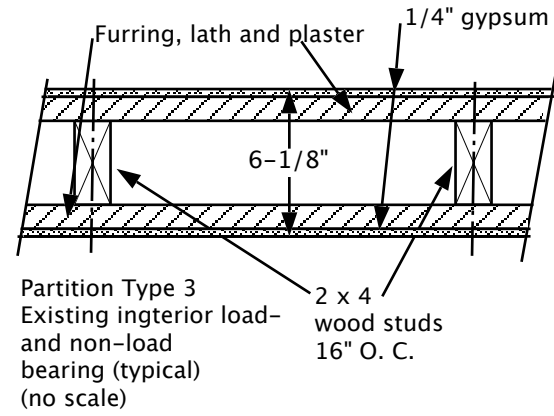
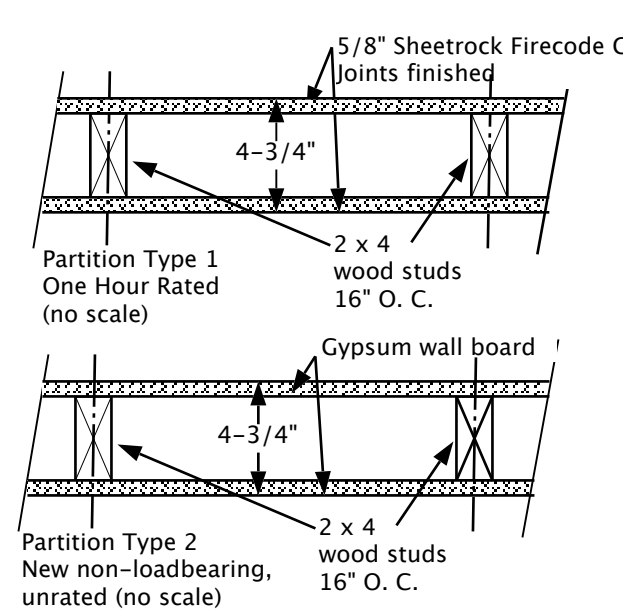

**5 Sherman Street  
Portland ME 04101**

Owner: Elise & Stephen Smith  
13 Deering St  
Portland ME 04101

Tel: 207.332.9588  
stephen.donnsmith1@gmail.com

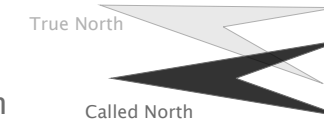

**Proposed Plan Lvl 1**  
1/4" = 1' - 0"  
06.12.2017

**A-1**

