

City of Portland, Maine - Building or Use Permit Application

389 Congress Street, 04101 Tel: (207) 874-8703, Fax: (207) 874-8716

| | | | | |
|----------------------|--|-------------|-------------|-------------|
| PERMIT ISSUED | | Permit No.: | Issue Date: | CBL: |
| | | 01-1393 | NOV 15 2001 | 034 H004001 |

| | | | |
|--|---|---|----------------------|
| Location of Construction: 71 Hanover St | Owner Name: City Of Portland | Owner Address: 389 Congress St | Phone: 874-8848 |
| Business Name: | Contractor Name: City of Portland Public Works Const | Contractor Address: 389 Congress Street Portland | Phone: 2077978531 |
| Lessee/Buyer's Name | Phone: | Permit Type: Building Miscellaneous | Zone: B-S |

| | | | | |
|--|--|---|--------------------------------------|--------------------|
| Past Use: City of Portland Fleet Parking Salt/Sand Storage | Proposed Use: City of Portland Fleet Parking Salt/Sand Storage | Permit Fee: | Cost of Work: \$22,000.00 | CEO District: 2 |
| | | FIRE DEPT: <input checked="" type="checkbox"/> Approved <input type="checkbox"/> Denied | INSPECTION: Use Group: U Type: 20 | |

| | | |
|--|---|---|
| Proposed Project Description: Install 2 foundations for salt/sand storage | Signature: <i>[Handwritten Signature]</i> | Signature: <i>[Handwritten Signature]</i> |
| PEDESTRIAN ACTIVITIES DISTRICT (P.A.D.) | | |
| Action: <input type="checkbox"/> Approved <input type="checkbox"/> Approved w/Conditions <input type="checkbox"/> Denied | | |
| Signature: | | Date: |

| | | |
|-------------------------|---------------------------------|------------------------|
| Permit Taken By: gad | Date Applied For: 11/08/2001 | Zoning Approval |
|-------------------------|---------------------------------|------------------------|

| | | | |
|---|---|---|---|
| <ol style="list-style-type: none"> This permit application does not preclude the Applicant(s) from meeting applicable State and Federal Rules. Building permits do not include plumbing, septic or electrical work. Building permits are void if work is not started within six (6) months of the date of issuance. False information may invalidate a building permit and stop all work.. | Special Zone or Reviews <input type="checkbox"/> Shoreland <i>NA</i> <input type="checkbox"/> Wetland <input type="checkbox"/> Flood Zone <i>Panel 13 zone C</i> <input type="checkbox"/> Subdivision <input checked="" type="checkbox"/> Site Plan <i># 2001-0273</i> Maj <input type="checkbox"/> Minor <input checked="" type="checkbox"/> MM <input type="checkbox"/> Date: <i>OK with conditions</i> <i>S 11/13/01</i> | Zoning Appeal <input type="checkbox"/> Variance <input type="checkbox"/> Miscellaneous <input type="checkbox"/> Conditional Use <input type="checkbox"/> Interpretation <input type="checkbox"/> Approved <input type="checkbox"/> Denied Date: | Historic Preservation <input checked="" type="checkbox"/> Not in District or Landmark <input type="checkbox"/> Does Not Require Review <input type="checkbox"/> Requires Review <input type="checkbox"/> Approved <input type="checkbox"/> Approved w/Conditions <input type="checkbox"/> Denied Date: <i>[Handwritten Signature]</i> |
|---|---|---|---|

CERTIFICATION

I hereby certify that I am the owner of record of the named property, or that the proposed work is authorized by the owner of record and that I have been authorized by the owner to make this application as his authorized agent and I agree to conform to all applicable laws of this jurisdiction. In addition, if a permit for work described in the application is issued, I certify that the code official's authorized representative shall have the authority to enter all areas covered by such permit at any reasonable hour to enforce the provision of the code(s) applicable to such permit.

SIGNATURE OF APPLICANT ADDRESS DATE PHONE

RESPONSIBLE PERSON IN CHARGE OF WORK, TITLE DATE PHONE

inspections

All Purpose Building Permit Application

If you or the property owner owes real estate or personal property taxes or user charges on any property within the City, payment arrangements must be made before permits of any kind are accepted.

| | | |
|--|--|---|
| Location/Address of Construction: <u>71-77 HANOVER STREET</u> | | |
| Total Square Footage of Proposed Structure <u>3,584 S.F.</u> | Square Footage of Lot <u>15,544 S.F.</u> | |
| Tax Assessor's Chart, Block & Lot Chart# Block# Lot# <u>34 H 4,5</u> | Owner: <u>CITY OF PORTLAND</u> | Telephone: <u>874-8848</u> |
| Lessee/Buyer's Name (If Applicable) <u>N/A</u> | Applicant name, address & telephone: <u>(874-8848)</u> <u>PUBLIC WORKS</u> <u>55 PORTLAND ST.</u> <u>PORTLAND, ME 04101</u> | Cost Of Work: \$ <u>22,000</u> Fee: \$ <u>FEE WAIVER LETTER ATTACHED</u> |
| Current use: <u>MUNICIPAL FLEET PARKING</u> | | |
| If the location is currently vacant, what was prior use: <u>—</u> | | |
| Approximately how long has it been vacant: <u>—</u> | | |
| Proposed use: <u>SALT/SAND STORAGE</u> | | |
| Project description: <u>SEE "COVER LETTER"</u> | | |
| Contractor's name, address & telephone: <u>PUBLIC WORKS</u> | | |
| Who should we contact when the permit is ready: <u>Anthony Lombardo</u> | | |
| Mailing address: <u>PORTLAND PUBLIC WORKS</u> <u>55 PORTLAND ST.</u> <u>PORTLAND, ME 04101</u> | | Phone: <u>874-8848</u> |

IF THE REQUIRED INFORMATION IS NOT INCLUDED IN THE SUBMISSIONS THE PERMIT WILL BE AUTOMATICALLY DENIED AT THE DISCRETION OF THE BUILDING/PLANNING DEPARTMENT, WE MAY REQUIRE ADDITIONAL INFORMATION IN ORDER TO APPROVE THIS PERMIT.

I hereby certify that I am the Owner of record of the named property, or that the owner of record authorizes the proposed work and that I have been authorized by the owner to make this application as his/her authorized agent. I agree to conform to all applicable laws of this jurisdiction. In addition, if a permit for work described in this application is issued, I certify that the Code Official's authorized representative shall have the authority to enter all areas covered by this permit at any reasonable hour to enforce the provisions of the codes applicable to this permit.

| | |
|--|----------------------|
| Signature of applicant: <u>Anthony W. Lombardo</u> | Date: <u>11/7/01</u> |
|--|----------------------|

This is not a permit, you may not commence ANY work until the permit is issued.

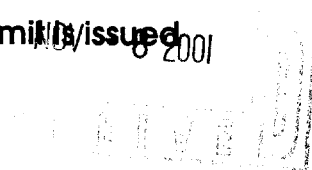

**CITY OF PORTLAND, MAINE
DEVELOPMENT REVIEW APPLICATION
PLANNING DEPARTMENT PROCESSING FORM
Zoning Copy**

2001-0273
Application I. D. Number
10/04/2001
Application Date
77 Hanover Street
Project Name/Description

City Of Portland
Applicant
389 Congress St, Portland, ME 04101
Applicant's Mailing Address
Lombardo, Anthony
Consultant/Agent
Agent Ph: (207)874-3800 Agent Fax: (207) 874-8848
Applicant or Agent Daytime Telephone, Fax

71 - 77 Hanover St, Portland, Maine
Address of Proposed Site
034 H004001
Assessor's Reference: Chart-Block-Lot

Proposed Development (check all that apply): New Building Building Addition Change Of Use Residential Office Retail
 Manufacturing Warehouse/Distribution Parking Lot Other (specify) 2 storage structures

3,584 sq. ft. .35
Proposed Building square Feet or # of Units Acreage of Site
B-5
Zoning

Check Review Required:

- Site Plan (major/minor) Subdivision # of lots _____ PAD Review 14-403 Streets Review
 Flood Hazard Shoreland Historic Preservation DEP Local Certification
 Zoning Conditional Use (ZBA/PB) Zoning Variance Other _____

Fees Paid: Site Plan \$400.00 Subdivision _____ Engineer Review _____ Date: 10/04/2001

Zoning Approval Status:

Reviewer Marge Schmuckal

- Approved Approved w/Conditions See Attached Denied

Approval Date 11/13/2001 Approval Expiration 11/13/2003 Extension to _____ Additional Sheets Attached

Condition Compliance Marge Schmuckal 11/13/2001
signature date

Performance Guarantee Required* Not Required

* No building permit may be issued until a performance guarantee has been submitted as indicated below

| | | | |
|---|----------------|--|-----------------|
| <input type="checkbox"/> Performance Guarantee Accepted | _____ | _____ | _____ |
| | date | amount | expiration date |
| <input type="checkbox"/> Inspection Fee Paid | _____ | _____ | |
| | date | amount | |
| <input type="checkbox"/> Building Permit Issued | _____ | | |
| | date | | |
| <input type="checkbox"/> Performance Guarantee Reduced | _____ | _____ | _____ |
| | date | remaining balance | signature |
| <input type="checkbox"/> Temporary Certificate of Occupancy | _____ | <input type="checkbox"/> Conditions (See Attached) | _____ |
| | date | | expiration date |
| <input type="checkbox"/> Final Inspection | _____ | _____ | |
| | date | signature | |
| <input type="checkbox"/> Certificate Of Occupancy | _____ | | |
| | date | | |
| <input type="checkbox"/> Performance Guarantee Released | _____ | _____ | |
| | date | signature | |
| <input type="checkbox"/> Defect Guarantee Submitted | _____ | _____ | _____ |
| | submitted date | amount | expiration date |

**CITY OF PORTLAND, MAINE
DEVELOPMENT REVIEW APPLICATION
PLANNING DEPARTMENT PROCESSING FORM
ADDENDUM**

2001-0273

Application I. D. Number

10/04/2001

Application Date

77 Hanover Street

Project Name/Description

City Of Portland

Applicant

389 Congress St, Portland, ME 04101

Applicant's Mailing Address

Lombardo, Anthony

Consultant/Agent

Agent Ph: (207) 874-3800

Agent Fax: 2078748848

Applicant or Agent Daytime Telephone, Fax

71 - 77 Hanover St, Portland, Maine

Address of Proposed Site

034 H004001

Assessor's Reference: Chart-Block-Lot

Approval Conditions of Planning

- 1 Because this is a temporary salt shed site until a permanent site is located, sidewalk and granite curb should be reinstalled once the salt shed use is removed from the site.

Approval Conditions of Zoning

- 1 This permit is being approved on the basis of plans submitted. Any deviations shall require a separate approval before starting that work.
- 2 A separate permit shall be required for the actual construction of the building, or any other work other than the foundation allowance

Application ID Number: 1-1393

Department: Zoning Status: Approved with Conditions Reviewer: Marge Schmuckal

Comments: 71 Hanover St - foundation only

Approval Date: 11/13/2001

Given On Date: 11/13/2001

OK to Issue Permit Name: Marge Schmuckal Date: 11/13/2001 Date 2:

Conditions Section:

This permit is being approved on the basis of plans submitted. Any deviations shall require a separate approval before starting that work.

A separate permit shall be required for the actual construction of the building, or any other work other than the foundation allowance.

Create Date: 11/13/2001 By: gg Update Date: 11/13/2001 By: mes



Public Works Engineering Memorandum

Date: 11/8/01

To: Michael Nugent, Building Inspections

From: Anthony Lombardo, P.E., Project Engineer *ALC*

RE: **Foundation PermitPublic Works Salt Shed Buildings**

On behalf of Bill Bray and Public Works, I am submitting an application for the purpose of installing foundations for two (2) salt/sand storage structures on the City owned property located at 71-77 Hanover Street.

Public Works would like to seek "building permit" approval in two phases. In this application, we are seeking only a "foundation permit". We have requested from our building manufacturer a stamped set of shop drawings for the proposed structures. Once we are in receipt of these drawings, we will submit to you an application and request for a "building permit". We expect to this material by November 15th.

The following information represents an itemized response to the submission requirements outlined and attached to the permit application:

- We have included one (1) copy of the deed for this property
- The floor plan, including dimensions, are specified on the Site Plan (2 copies attached)
- As referenced above, one (1) copy of the Site Plan is included with this submission
- Two (2) copies of the construction details of the site work and foundation installation have been included with this submission. We have also included two (2) copies of the "installation manual", which includes detailed information related to the erection of each building
- The Site Plan, construction details and boundary survey have been plotted on 11"x 17" paper
- We have included a copy of the "site plan approval" letter
- Also included is an e-mail from Larry Mead, authorizing the waiver of fees associated with the construction of this project

Project Description

The entire site was previously utilized as a Public Works fleet/employee parking lot. The site was entirely surface with pavement of varying condition. Our proposal includes the erection of two (2) tension fabric covered, steel truss arch structures manufactured by *COVER-ALL*. Each building will have a footprint 34 feet wide by 58 feet long. The purpose of these buildings will be to provide support for “winter operations” and response to the initial snowfall resulting from each winter event. Each building will store either sand or a sand/salt mixture.

The entire site will be stripped of existing pavement and the first ten (10) inches of gravel. The site will then be regarded and paved as specified on the plans. A loading ramp will be constructed to support loading of salt and sand into winter maintenance vehicles. Construction details for the ramp are included with the site plan. When “winter operations” has concluded for the season, the site will be utilized for Public Works fleet parking.

We are requesting your assistance in obtaining an expeditious review of our “foundation permit” application. Please let me know if any additional information is necessary to complete or enhance our application package. I can be reached at 874-8848 to answer any questions. Public Works appreciates your cooperation and assistance regarding our proposal and permit request.

LANCASTER

231 | 233 | 255 | 237 | 239

105±(d)
105±(d)

William W. Mason
to
City of Portland
988-166 Warr. 1917

Ezra Russell
to
City of Portland
1849 Q.C. 213/449

16,812±sq. ft.

The deed, from Ezra Russell
to City of Portland; included
all the Land 100' more or less each
side of Hanover St., from a point
near Lancaster St., to the
U.S. Government Channel in
Back Cove.

STREET

HANOVER

KENNEBEC

Deed 530
See Sheet 66 382

Iron

Lumblandy April 25 1849, Personally appeared the above named
Abner Stebbins & acknowledged the above assignment to be his free act
and deed before me, William Ross, Justice of the Peace.

Received April 25 1849 at 11.20 A.M. I recorded from the original
By William Ross, J.P.

"I now all men by these presents, that Ezra Russell
of Portland, in the County of Cumberland and State of Maine, Guardian
of Robert Ford Dyer of said Portland, a minor, having obtained R. F. Dyer
License from the Honorable Smith Pierce, Judge of Probate for said County,
to sell and convey the real estate of the said Robert F. Dyer, and
having agreed to the directions of the said Court, given due notice of
said sale, did, on the twenty third day of April instant pursuant to the City of Portland
license and notice aforesaid, sell at private sale to the City of Portland,
the estate hereafter described for the sum of eleven hundred Dollars, \$1100,
being the highest offer therefor by a certain parcel of land and flats
situate at the foot of Hanover Street in said Portland, and on each side
thereof, described as follows, viz: Beginning at a stake on the easterly
side line of Hanover Street, forty feet from the highwater mark of
Back Cove, thence running Easterly at right angles with Hanover
Street about one hundred feet to Polly Green's Land & Westly at
right angles with the same street about one hundred feet from
the Westly side of said Street to Benjamin Sarabee's Land, and
from these bounds to extend Northwesterly between the Land of said Green
and Sarabee to the Channel of Back Cove, subject to a conveyance
from Emma Ford to James Deering of right to dig and open a creek or
channel across said flats a particularly described in a deed from said
Emma Ford & Polly & Henry Green dated June 13. 1836, & recorded in Cumberland
land Registry to which reference is hereby made for a more particular
description. The premises hereby conveyed being part of the estate assigned to said
Robert in the division of Emma Ford's estate made in 1845, a record of
which may be found in the Probate Office, Book 49, Page 172, is hereby
referred to. Therefore I, the said Ezra Russell, do by virtue
of the power and authority with which I am as aforesaid vested
and in consideration of the aforesaid sum of eleven hundred dollars
to me paid by the City of Portland, the receipt whereof I do hereby
acknowledge, have given, granted, and sold, and by these presents
do give, grant, sell and convey to the said City of Portland & their
assigns forever, the above described premises, with all the privileges

J. Ross
6
Seal
Bill

and appurtenances to the same belonging. To have and to hold
the same in manner as aforesaid, to the said city and their assigns
forever. And I the said Ezra Russell in my said capacity
do covenant to and with the said city and their assigns that
I have in all things observed the rules and directions of the law
in advertising and selling said estate, and have good right and
lawful authority to sell and convey the same in manner as aforesaid.

In witness whereof I have hereunto set my hand and
seal, in my said capacity, this twenty third day of April in the year
of our Lord one thousand eight hundred and forty nine.
Signed, sealed & delivered in
presence of Mrs. Willis

Ezra Russell, T.C.

Lumberland, April 24, 1849. Then personally appeared the above
named Ezra Russell and in his capacity of Guardian aforesaid, ack-
nowledged the foregoing instrument to be his free act & deed.

Mrs. Willis Just. Peace

Received April 26, 1849, at 35 minutes P.M. & recorded from the original
By William Ross, Regr.

This Indenture made September 11th 1847 between
John Sloan & Caroline Sloan of New Albany, Elroy County
Indiana of the first part, and Sarah Hunt of Westbrook, Maine,
of the second part - Witnesseth, That the parties of the first part
in consideration of their mutual love & affection for the party of the
second part, hereby give, bargain & sell to the party of the second
part all their right, title & interest in & to any and all of the personal
estate of Jacob Hunt, deceased, late of said Westbrook, husband
of said Sarah & father of said Caroline. To have and to hold all
of said personal estate to the sole and only use of said Sarah
and her assigns forever.

In testimony whereof the parties of the first
part have hereunto set their hands and seals the day & year first
written.

John Sloan T.C.

Caroline Sloan T.C.

State of Indiana,
Elroy County, Oct. 5. Before me the undersigned a Justice of the Peace
in and for said county aforesaid, personally appeared John Sloan & Caroline
Sloan the signers and sealers of the above instrument and acknowledged
that they signed, sealed and delivered the same as and for their
free act & deed, for the purposes & considerations therein specified.



CITY OF PORTLAND

October 15, 2001

Mr. Anthony Lombardo
City of Portland
389 Congress Street
Portland, ME 04101

RE: Salt Shed Structures, 71 Hanover Street (Job #2001-0273, CBL #34-H-4)

Dear Tony:

On October 15, 2001, the Portland Planning Authority granted minor site plan approval to construct two (2) salt shed structures to be located at 71 Hanover Street. The approval is subject to the following condition:

1. Because this is a temporary salt shed site until a permanent site is located, sidewalk and granite curb shall be reinstalled once the salt shed use is removed from the site.

The approval is based on the submitted site plan. If you need to make any modifications to the approved site plan, you must submit a revised site plan for staff review and approval.

Please note the following provisions and requirements for all site plan approvals:

1. The site plan approval will be deemed to have expired unless work in the development has commenced within one (1) year of the approval or within a time period agreed upon in writing by the City and the applicant. A one-year extension may be granted by this department if requested by the applicant in writing prior to the expiration date of the site plan. If there are any questions, please contact the Planning Staff.

Sincerely,

Alexander Jaegerman
Chief Planner

From: Larry Mead
To: Lombardo, Anthony
Date: Tue, Oct 2, 2001 2:06 PM
Subject: Re: Salt Shed Site Plan Fees

To: Anthony Lombardo
From: Larry Mead, Assistant City Manager

Date: October 2, 2001

RE: Salt Shed Site Plan Fees

As is the practice with municipal projects, all fees associated with the City's site plan application for the salt shed project on Hanover Street should be waived.

CC: William Bray

TAS GROUND MOUNT Owner's Manual

TRUSS ARCH STRUCTURE

SERIES: 18 / 32

Model - TAS #18-320-10

Model - TAS #32-320-10

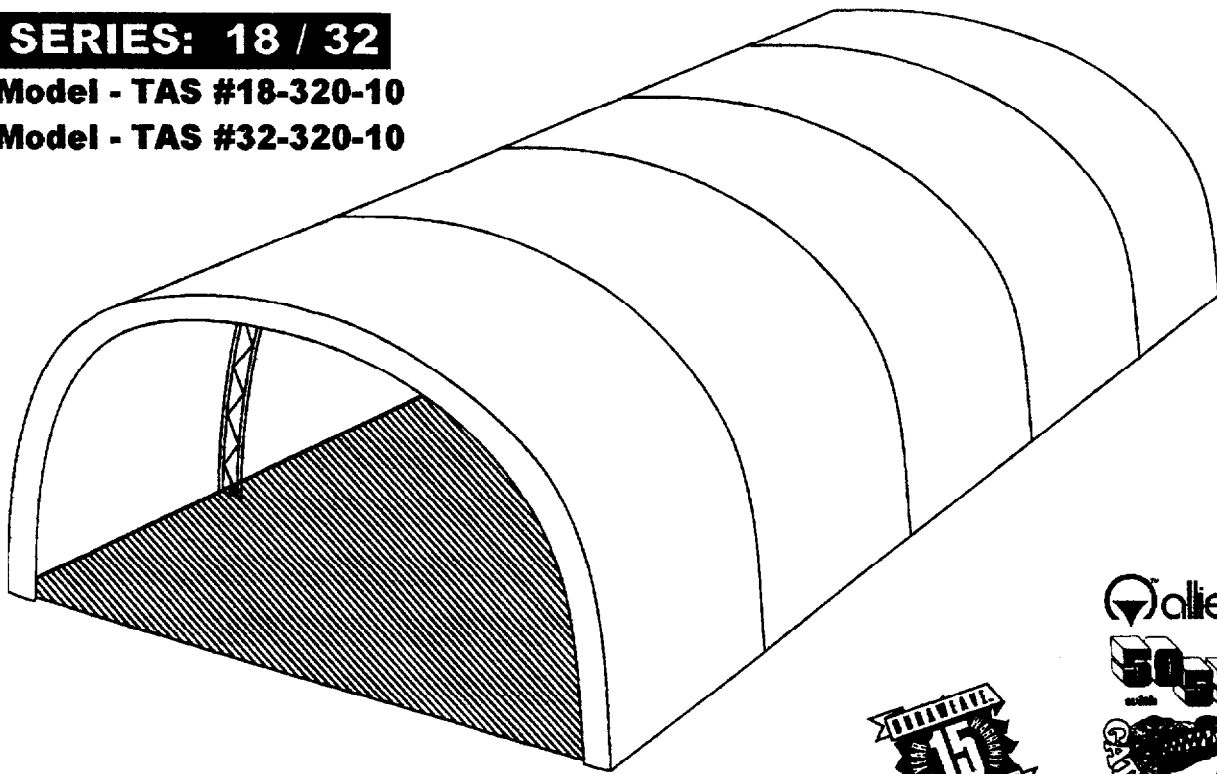

DURAWEAWE™ Cover

WinchLoc™ Fastening System

INCLUDES

FOUNDATION
FRAMEWORK
COVER

ESS END ENCLOSURES
AND
DURATRAC DOORS ARE
SHIPPED WITH THEIR OWN MANUALS.

Building Components

| | | | |
|--|---|--|---|
| <p>99.18#</p> <p>BASE END TRUSS LEFT TAS 18'</p> <p>300410</p> <p>48.83#</p> | <p>99.18#</p> <p>BASE END TRUSS RIGHT TAS 18'</p> <p>300420</p> <p>97.91#</p> | <p>101.66#</p> <p>BASE TRUSS COMMON TAS 18'</p> <p>300430</p> <p>97.91#</p> | <p>53.79#</p> <p>CENTER TRUSS COMMON TAS 18'</p> <p>300440</p> <p>100.39#</p> |
| <p>100 5/8"</p> <p>CENTER END TRUSS TAS 18'</p> <p>300450</p> | <p>206 9/16"</p> <p>BASE END TRUSS LEFT TAS 32'</p> <p>300612</p> | <p>206 9/16"</p> <p>BASE END TRUSS RIGHT TAS 32'</p> <p>300622</p> | <p>206 9/16"</p> <p>BASE TRUSS COMMON TAS 32'</p> <p>300632</p> |
| <p>115.58#</p> <p>CENTER TRUSS COMMON TAS 32' / 42'</p> <p>300640</p> | <p>110.62#</p> <p>CENTER END TRUSS 32' COMMON END TRUSS 42'</p> <p>300650</p> | <p>6.82#</p> <p>TAS / IAS 5' 2 HOLE PURLIN 1.66" - 14 GA</p> <p>310450</p> | <p>6.76#</p> <p>TAS 5' 3 HOLE PURLIN 1.66" - 14 GA</p> <p>310460</p> |
| <p>9.79#</p> <p>TAS 5' RIDGE PURLIN 2 3/8" - 14 GA</p> <p>310470</p> | <p>10.81#</p> <p>TAS / IAS 8' 2 HOLE PURLIN 1.66" - 14 GA</p> <p>310895</p> | <p>10.80#</p> <p>TAS 8' 3 HOLE PURLIN 1.66" - 14 GA</p> <p>310435</p> | <p>15.89#</p> <p>TAS 5' RIDGE PURLIN 2 3/8" - 14 GA</p> <p>310670</p> |
| <p>13.61#</p> <p>TAS / IAS 10' 2 HOLE PURLIN 1.66" - 14 GA</p> <p>310890</p> | <p>13.69#</p> <p>TAS 10' 3 HOLE PURLIN 1.66" - 14 GA</p> <p>310235</p> | <p>19.95#</p> <p>TAS 10' RIDGE PURLIN 2 3/8" - 14 GA</p> <p>310660</p> | <p>41.52#</p> <p>FASTENING TUBE 2 3/8" - 14 GA</p> <p>313011</p> |
| <p>1.20#</p> <p>TAS WEB PLATE 3/16" PLATE</p> <p>310620</p> | <p>1.45#</p> <p>TAS TAB WEB PLATE ASSEMBLY</p> <p>310820</p> | <p>0.85#</p> <p>TAS PURLIN BRACKET 3/16" PLATE (2 3/8" PIPE)</p> <p>310860</p> <p>804840</p> | <p>1.33#</p> <p>TAS SADDLE BRACKET w/ TAB ASSEMBLY</p> <p>310850</p> |
| <p>0.68#</p> <p>TAS PURLIN BRIDGE PLATE 3/16" PLATE</p> <p>310840</p> | <p>0.94#</p> <p>TAS CROSS CABLE - 90' 3/16" CABLE ASSY</p> <p>804810</p> | <p>0.05#</p> <p>CABLE CLAMP - 3/16"</p> <p>804850</p> | <p>3/4#</p> <p>PVC TUBE 3/4"</p> <p>900290</p> |
| <p>3.60#</p> <p>LASHING WINCH RIGHT HAND</p> <p>804073</p> | <p>3"</p> <p>RATCHET c/w D-RINGS</p> <p>321020</p> | <p>2 1/2"</p> <p>FASTENING TUBE END PLUG 2 3/8" PLASTIC</p> <p>804190</p> | <p>36"</p> <p>2LS3 TIE DOWN STRAP FOR 2 3/8" PIPE</p> <p>320520</p> |



We would like to take this opportunity to thank you for purchasing a Cover-All™ building. We believe it will serve you well for many years. Should you have any questions or comments during or following the installation, please feel free to contact your Cover-All™ dealer.

IMPORTANT – READ MANUAL FIRST

Improper Site Preparation, Assembly and Maintenance may invalidate warranty and cause unnecessary and costly mistakes. If you have any questions contact your local dealer.

MAINTENANCE SCHEDULE

A. INSTALLATION INSPECTION - 1 WEEK

1. Lashing Winches - ensure the straps are secure and the cover is taut. Check tension on winches with a torque wrench 25 – 35 ft. lbs. **Do not exceed 35 ft. lbs.**
2. Belting - check for premature belting wear and ensure tightness.
3. End Flaps - ensure the flaps remain taut and securely fastened.
4. Puncture Marks - caused by flying debris or other accidental damage should be repaired **immediately** (your local dealer can supply this service).

B. INSTALLATION ADJUSTMENT

1. The cover of your Cover-All™ building may relax after installation. It is important to keep the cover tight to prevent wear and ensure a long life. Use a torque wrench to adjust winch tension on the *inside winches only* 25 – 35 ft. lbs. **Do not exceed 35 ft. lbs.** Tighten the end winches until the fastening pipe is level.

NOTE: *Building covers installed during cooler weather tend to relax more than covers installed during warmer weather. If your cover was installed in cooler weather recheck its tightness on the first available warm sunny day.*

2. It is of utmost importance that the end flaps remain secure and tight at all times as they are subject to constant wind pressure. Tighten as required.

NOTE: *Failure to ensure the above steps are carried out will invalidate the warranty.*

C. QUARTERLY MAINTENANCE

1. Repeat above "INSTALLATION INSPECTION - 1 WEEK" a minimum of 4 times per year.

REQUIRED EQUIPMENT AND MATERIALS

EQUIPMENT FOR GENERAL INSTALLATION

1. String and string level for alignment.
2. Stakes and tape to mark pile locations.
3. 2 to 4 lengths of rope 75' or longer.
4. Movable scaffolding or platform lift.
5. Temporary bracing material such as 2" x 6" x 16' pieces of dimensional lumber or rope.
6. Torque wrench.
7. **Optional** – A transit (available from a local rental store), impact wrench.

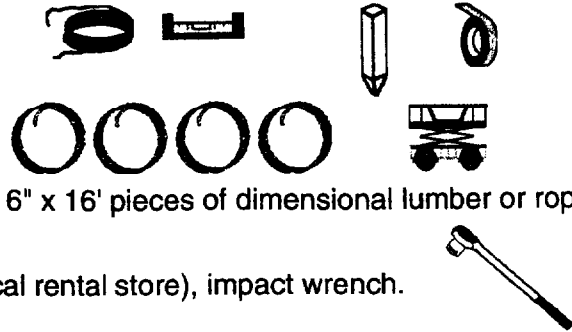

EQUIPMENT REQUIRED FOR CONCRETE PILE INSTALLATION

1. Plywood templates (one for each pile) to position anchor bolts.
See B3, Page 7.
2. 5/8" anchor bolts (minimum 18" long) and nuts. Four (4) for each pile.
3. Equipment to suitably drill an 18 - 20 inch hole to a depth of 6 feet in the ground.
4. Concrete (recommended concrete specifications: Type 50, 3000 psi or 25 MPa).
Note: A 20" hole 6' deep requires 1/2 yard.
5. #6 (20 M) rebar, 6' long. Four (4) pieces for each pile.
6. #3 (10 M) circular ties (7 required for each 6' pile).
7. Sonotubes (forms) for each pile. Minimum 18" diameter.

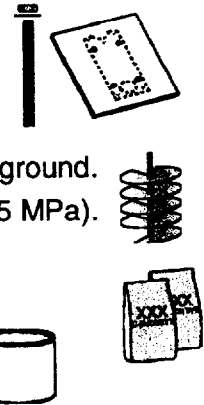

NOTE: Materials specified are for mounting the building on ground level piles with trusses 10' on center. If you are installing on taller piles check with a geotechnical engineer for the recommended pile specifications.

MATERIAL REQUIRED FOR CONCRETE PAD INSTALLATION

Concrete pads must be one (1) foot wider and one (1) foot longer than the building's dimensions to ensure proper anchor support. See Page 8.

Eg. 18' (w) x 40' (l) requires a 19' x 41' outside dimension pad.

1. 5/8" x 4" wedge anchor bolts - 4 per base plate.
2. 5/8" masonry bit.
3. Drill.

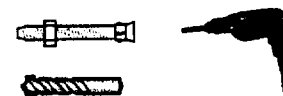

EQUIPMENT FOR GROUND INSTALLATION - SERIES 18 ONLY

1. Sledge hammer.
2. 4 foot pry bar.

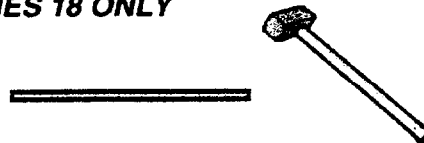

EQUIPMENT FOR BUILDINGS OVER 130'

1. Caulking gun



COVER-ALL BUILDING SYSTEMS™ IS NOT RESPONSIBLE FOR ANY DAMAGES WHICH MAY OCCUR DURING INSTALLATION.



TABLE OF CONTENTS

| | Page |
|---|-------|
| A - . SITE PREPARATION/FOUNDATION | 5 |
| B - INSTALLATION OF PILES..... | 5 |
| C - INSTALLATION ON CONCRETE PAD..... | 8 |
| D - INSTALLATION ON GROUND (SERIES 18 ONLY) | 8 |
| E - PREPARING TO ERECT THE STEEL FRAMEWORK..... | 9 |
| F - ERECTING THE STEEL FRAMEWORK..... | 10 |
| G - INSTALLING THE FASTENING PIPES | 15 |
| H - INSTALLING THE DURAWEAWE™ COVER | 16 |
| I - ASSEMBLY / TIGHTENING OF END FLAP | 17 |
| J - TIGHTENING THE COVER..... | 18 |
| APPENDIX A – Vent Frame..... | 19 |
| APPENDIX B – Buildings over 130' In Length..... | 20 |
| SQUARING A FOUNDATION..... | 23 |
| WARRANTY..... | 24-25 |
| CONVERSIONS | 25 |
| TEMPLATE | 26 |

NOTE

COVER-ALL BUILDING SYSTEMS™ IS NOT RESPONSIBLE FOR FOUNDATION DESIGN OR INSTALLATION.

*Please consult with a qualified engineer for soil conditions in your area.
The foundation suggestions below are acceptable for
soil conditions given a soil capacity of
125(2500) End Bearing kPa(psf); 20(400) Skin Friction kPa(psf).*

A - SITE PREPARATION / FOUNDATION

1. Start with a level site.
2. Stake out the location of the corner piles A, B, C and D. Use an accepted method to make the foundation straight and square. See *Squaring A Foundation (Page 25)* for assistance.
3. String a line from A to B and from C to D.
4. With a measuring tape attached to stake A & C, measure and stake the pile intervals along the length of the building using a **running measurement**.
Eg. 5' centers - 5', 10', 15' etc.
5. Check linear measurements by measuring the distance between each stake. Distance should be equal. Check the square of the foundation by measuring diagonally. Diagonal measurements should be equal. Continue to check the width and diagonal measurements the entire length of the building.

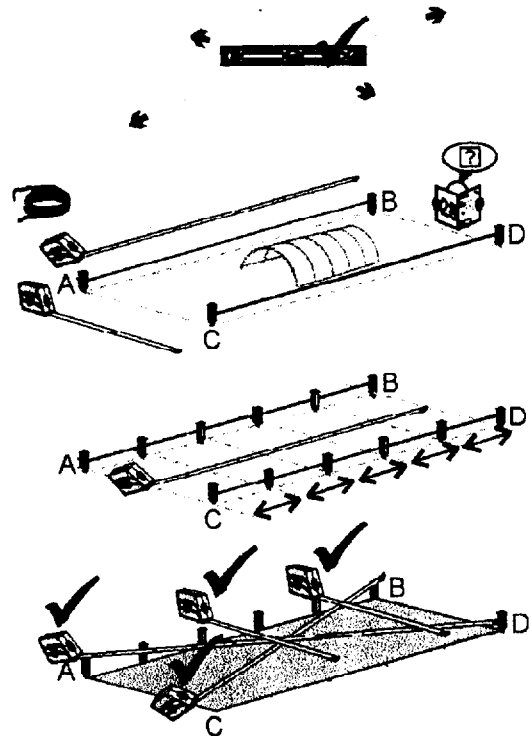

NOTE: Buildings over 130' in length have more than one cover. Even with this feature, the foundation continues as a running measurement for the entire length of the building.

B - INSTALLATION OF PILES

B1. DRILL HOLES.

1. Drill an 18" -20" hole a minimum of 6' deep at each stake. (Ensure that a qualified operator is running the auger) *Your soil and frost conditions may warrant a larger or deeper pile - check with a qualified engineer before drilling.*
2. After the holes are drilled, check once more to ensure that the holes are placed correctly, verifying all measurements. If some holes are out of line, you may have to widen them to maintain pile alignment.

SERIES 18 / 32

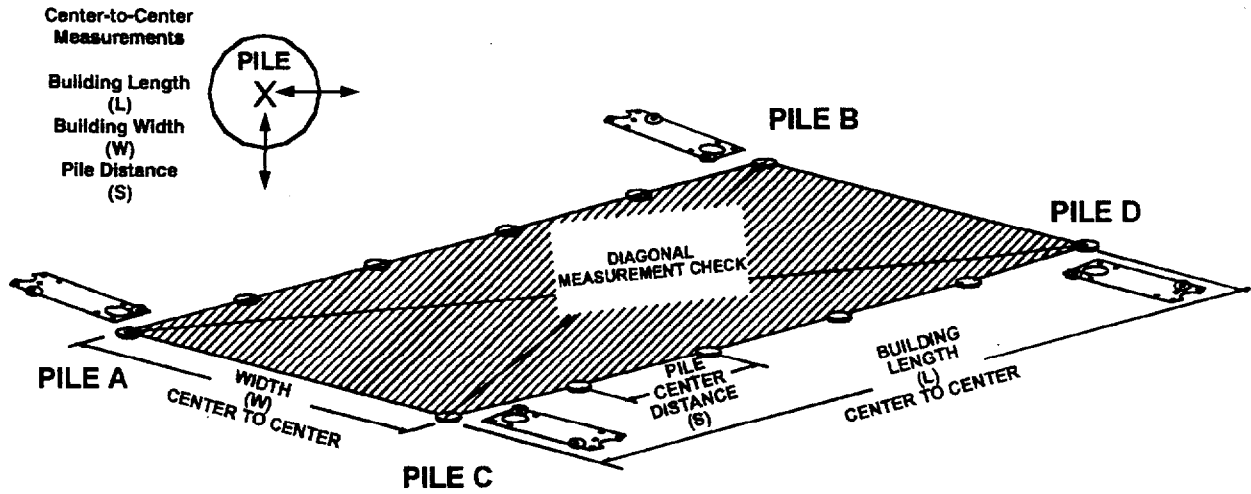

SERIES 18

(W) WIDTH = 17' 0"

(S) PILE CENTERS = 10' 0"

SERIES 32

(W) WIDTH = 31' 0"

(S) PILE CENTERS = 10' 0"

RUNNING MEASUREMENTS

(S) PILE CENTERS = 10'
10', 20', 30', 40', 50' etc.

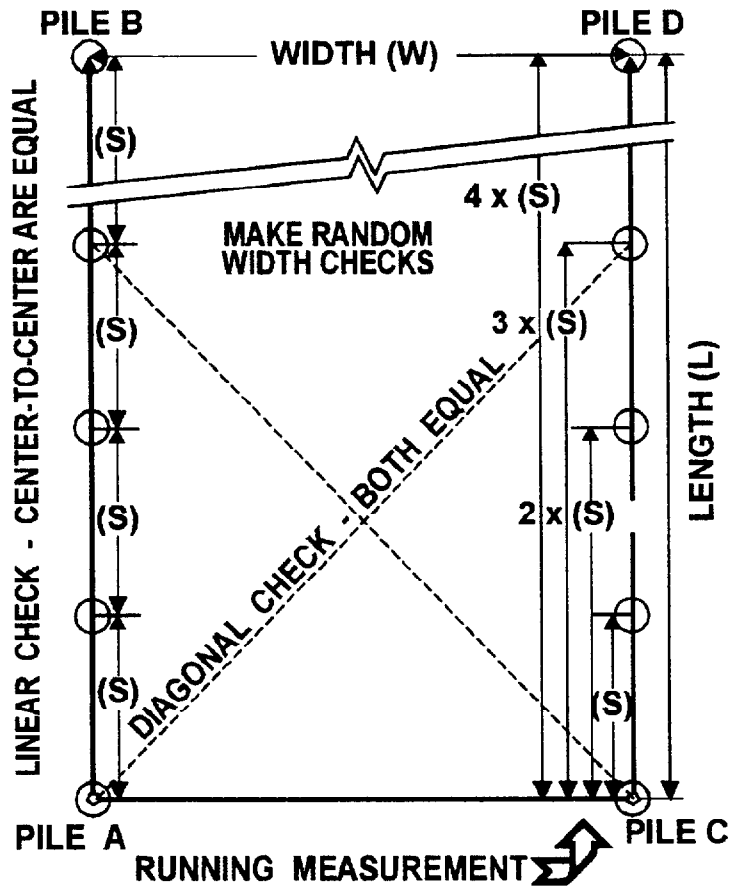

ALL MEASUREMENTS ARE CENTER-TO-CENTER

B2. REBAR AND FORMS.

A 6' pile requires eight (8) #3 circular ties.

- The circular ties should be placed as follows:
 1st tie - 1" from the top end of the rebar.
 2nd tie - 3" on center below the first tie.
 3rd tie - 12" on center below the 2nd tie.
 4th to 8th - 10th ties - every 12" on center.
- Place rebar and sonotubes (forms) in each hole and restring the lines.
- Use an accepted method to set the top edge of the sonotubes (forms) to the height of the level line. *Do not exceed 6" above ground level. Use a surveyors level if one is available.*
- Center the rebar, set the height of the rebar, and secure in position.

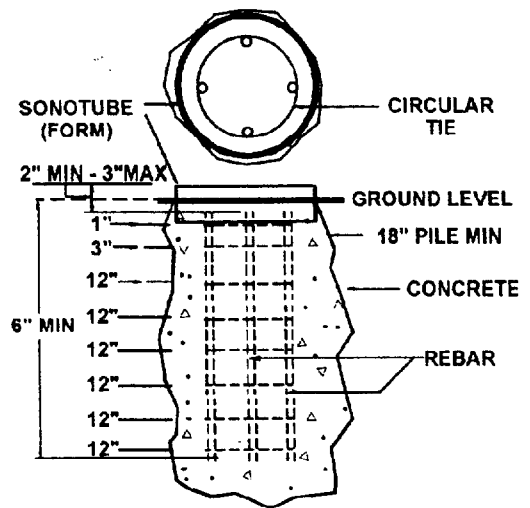

NOTE: *Top of rebar must be a minimum of 2" and a maximum of 3" below the top edge of the form (level line). The first tie should be 3" below the top edge of the form.*

B3. INSTALLING THE ANCHOR BOLTS.

- Using the information on the back cover, make plywood templates of the truss base.
- Using the plywood templates, install the anchor bolts in the piles. Leave 2" of bolt exposed above the concrete surface. Protect exposed threads from concrete. *Make sure center-to-center measurements are maintained.*

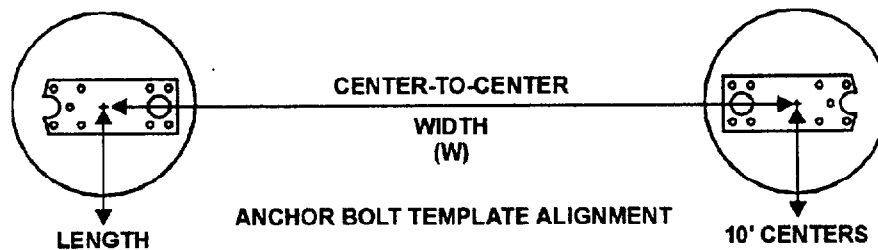

B4. POUR THE CONCRETE PILES.

- Pour the concrete level in the sonotubes (forms) using proper concrete pouring techniques. *It is important to tamp or vibrate the concrete in order to get rid of any air pockets.*

C - INSTALLATION ON CONCRETE PAD

1. Pad must be 1' longer and 1' wider than building dimensions.
2. Install the anchor bolts as described in B3 when pouring the concrete pad *or* after the pad has cured install 5/8" x 4" wedge anchor bolts (*not supplied*).

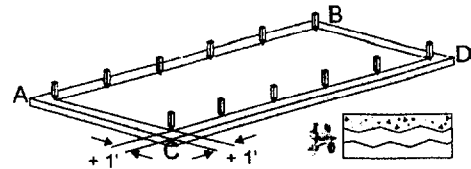

D - INSTALLATION ON GROUND - SERIES 18 ONLY

BASE REQUIREMENTS: Medium dense sandy gravel, very stiff to hard silts and clays. The geological soil classification is glacial till; hardpan; marls.
Contact a qualified engineer for soil conditions in your area.

1. Select and stake out building site as outlined in Section A, (Page 5) steps 1 through 5. (Refer to diagram Page 6)
2. Place a template at corner A so it is centered and square to the string and tape marker.
3. Mark the location of the anchor holes according to the diagrams on this page. **The corner duck bill anchors must use the indicated holes to allow proper lashing winch mounting and tightening.**

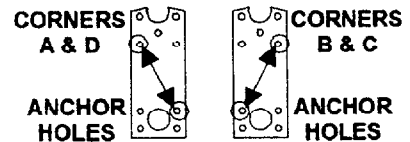

4. To install a duck bill anchor, place the small end of the duck bill setting cable over the threaded bolt of a duck bill anchor and secure with a washer and nut until the nut is flush with the end of the bolt.
5. Place the duck bill on the end of the driving rod and using the sledge hammer, drive the anchor straight down at one anchor hole location until the top of the bolt is 2" **below** ground level. Remove the driving rod.
6. Insert a pry bar into the exposed loop of the duck bill setting cable and pull up until the top of the bolt is 2" **above** ground level. You may want to use a block of wood as a fulcrum. **Do not use the driving rod as a pry bar.**

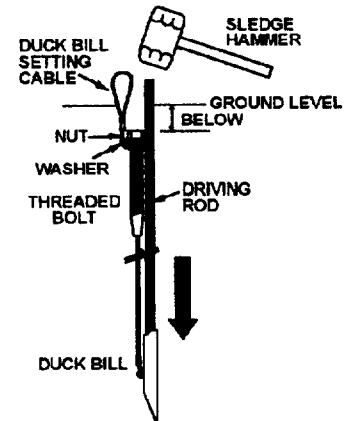

NOTE: The duck bill anchor normally requires 4" of travel.
 Distance may vary in different soil conditions.

7. Remove the nut, washer and duck bill setting cable.
8. Repeat the installation procedure at each corner and each arch base location. (2 anchors per base)

Hint: Inside arch anchor holes can be either the A-D or B-C pattern. A consistent pattern will simplify the winch mounting procedure.

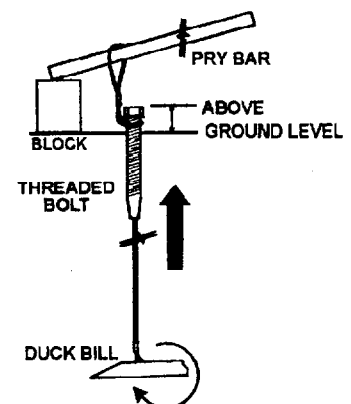

E - PREPARING TO ERECT THE STEEL FRAMEWORK

E1. IDENTIFY AND LAYOUT ARCH TRUSSES.

1. Identify and separate the inside trusses from the end trusses. End trusses have a 1/2 (one-half) coupler plate. Inside trusses have a full coupler plate.

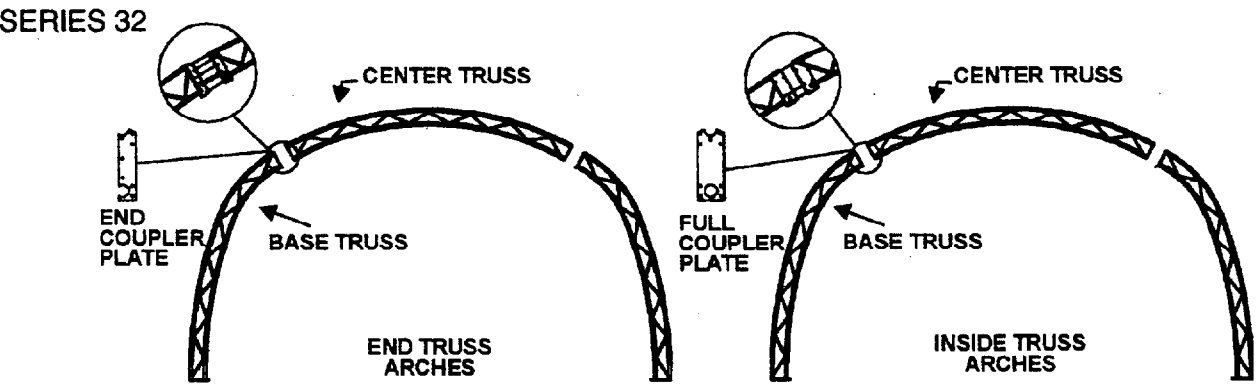
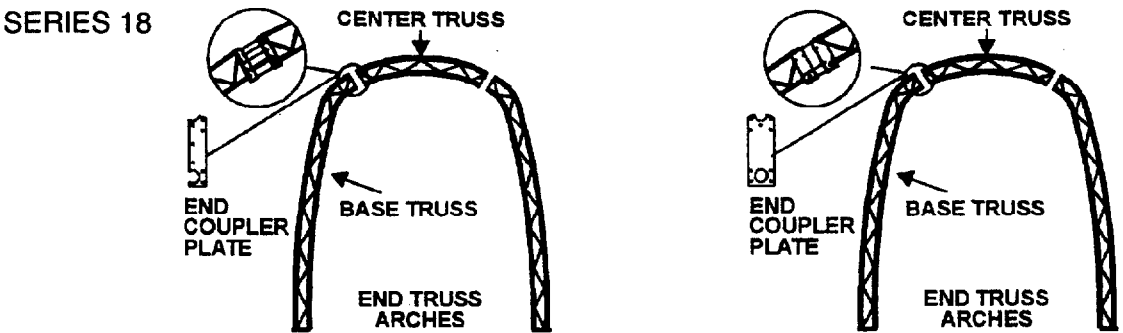

E2. CONNECT (BOLT) TRUSSES TOGETHER.

1. Bolt together all trusses using 5/8" x 2" bolts. Install all bolts and tighten securely.

Hint: Determine which **FULL** coupler plates will have 3-hole purlins attached. It is not necessary to tighten the purlin bolts on these plates until after the purlins are installed.

Eg. An 80' building requires nine (9) complete arches: - Two (2) outside arches with 1/2 plate couplers: - Seven (7) inside arches with full plate couplers.

WARNING: All 1/2 coupler plates must have all bolts installed and tightened when lifting arch into position or damage may occur.

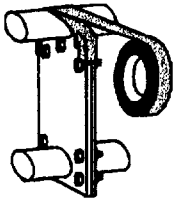

2. **DUCT TAPE ALL COUPLER PLATES** of the trusses generously to ensure that there are no jagged or sharp edges on which the cover may catch when being pulled over.

E3. GROUND MOUNTED - SERIES 18 ONLY.

1. Fasten a lashing winch to every base using a 5/8" x 2" bolt & nut. The winch release faces the inside of the building. **REMEMBER** the **duck bill anchor pattern** used in installing the anchors (Section D). Don't fasten the lashing winch in a hole that will be occupied by the anchor.



E4. IDENTIFY PURLINS AND MOUNTING BRACKETS.

3-Hole X-Purlin - 116 1/4" long (hole center-to-center) 1.66" dia.



2-Hole S-Purlin - 115" long (hole center-to-center) 1.66" dia.



2-Hole Ridge R-Purlin - 116" long (hole center-to-center) 2.375" dia.



Saddle Bracket w/tab - attaches to the lower tube of the arch using one 7/16" x 3 1/2" carriage bolt/nut.

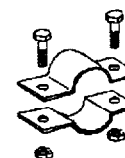
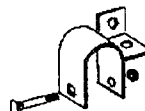

Purlin Bracket - installed in pairs, attach to the lower tube of the inside arches using two 5/8" x 2" bolts/nuts.



Purlin Bridge Plate - attaches to the top of the purlin brackets where 3-hole X-purlins are required

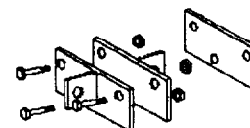

Tab Web Plate / Web Plate - attach to the truss webbing where 3-hole X-purlins and 2-hole R-purlins are required using three 3/8" x 2" bolts/nuts.

F - ERECTING THE STEEL FRAMEWORK

REMEMBER: GROUND MOUNT SERIES 18 – LASHING WINCHES MUST BE INSTALLED BEFORE ERECTION. See Section E3, Page 9

F1. HOIST END ARCH INTO POSITION.

1. Place one end arch (1/2 coupler plates) into position with the base of the arch pointing outward.

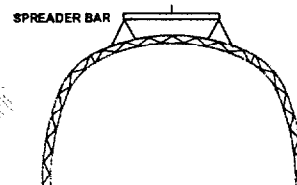
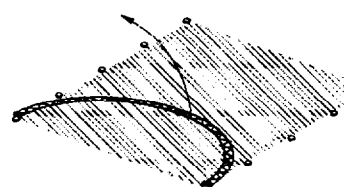

2. Attach web plates and tab web plates using 3/8" x 2" bolts/nuts as required. Attach saddle brackets w/ tabs using one 7/16" x 2 1/2" carriage bolt/nut as required. See Pages 11 & 12 for purlin locations.

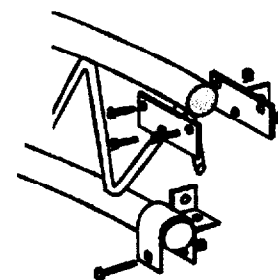

NOTE: Use extreme caution when lifting arches. ALWAYS use a spreader bar.

2. Elevate the truss into its upright position and secure on the corner anchor bolts with nuts. **Do not tighten nuts fully.**
3. Brace the arch sufficiently then tighten nuts fully *before* removing the lift equipment.

NOTE: It is important to brace this first truss perfectly straight as all other arches will be aligned to it. Leave bracing in place until entire framework is complete.

F2. HOIST THE SECOND ARCH INTO POSITION.

1. Move an inside arch (full coupler plates) into position and attach web plates in the top center position as required. See Pages 11 & 12.

SERIES 18

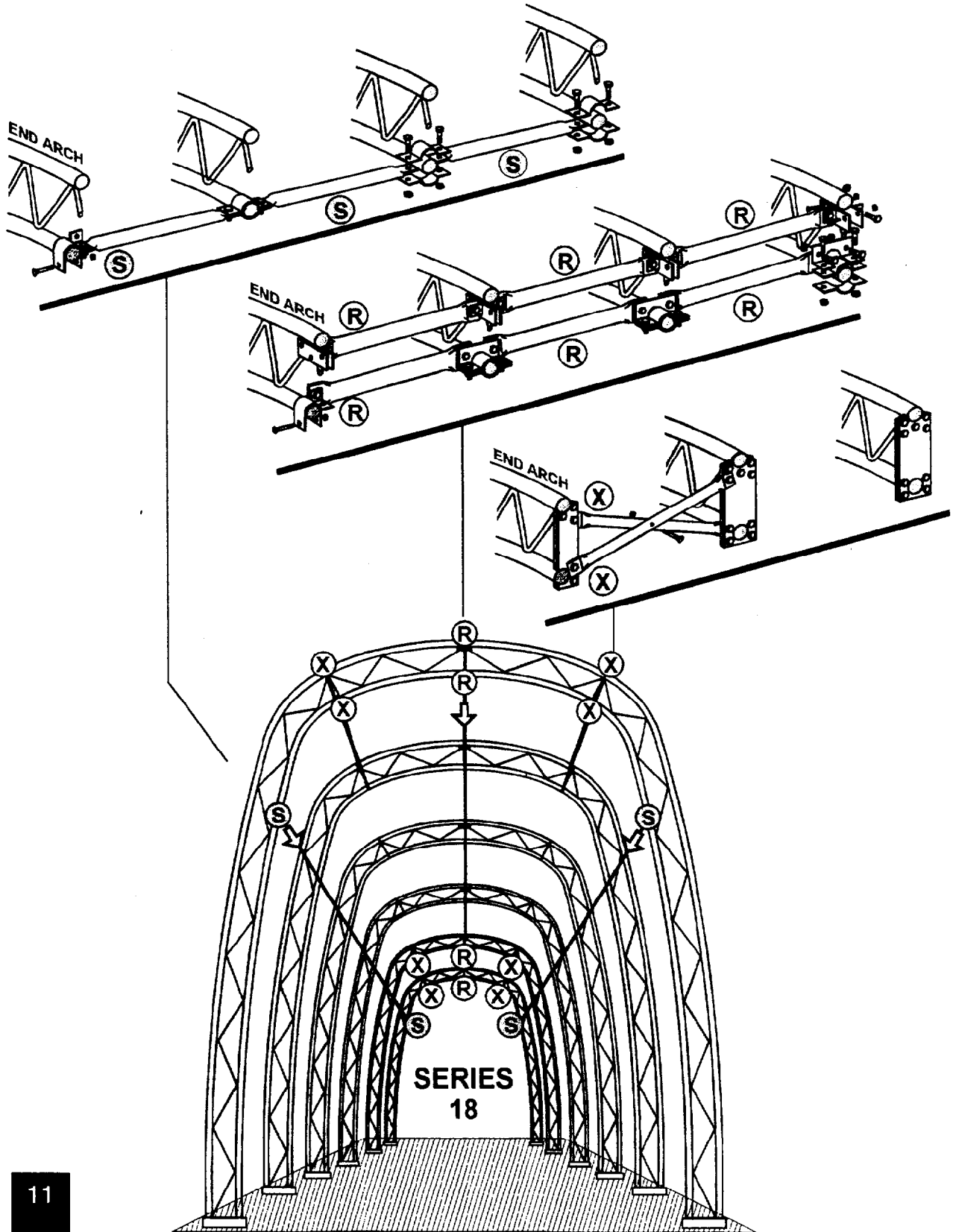

SERIES 32

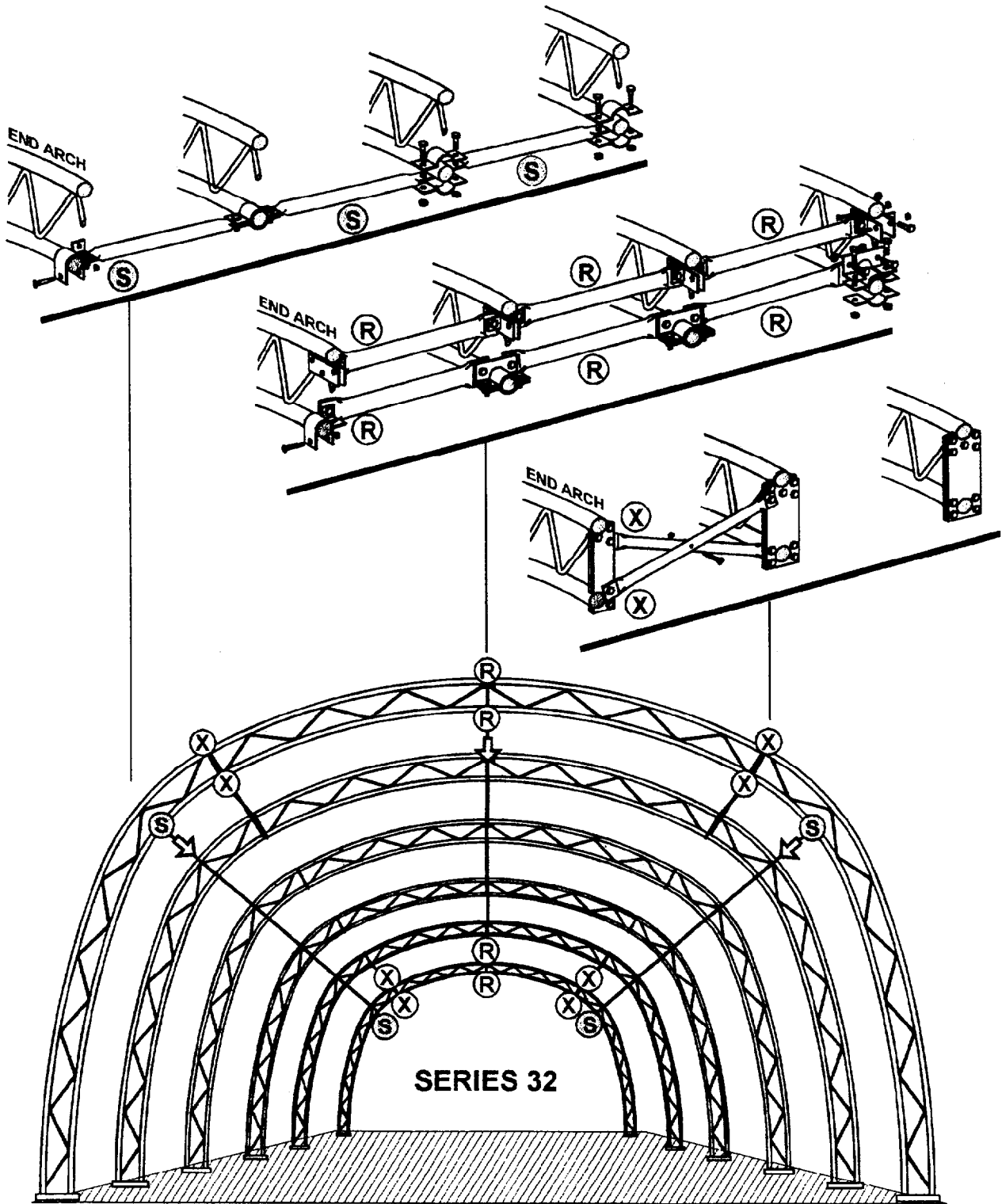

2. **Top Center** – Attach purlin brackets along with purlin bridge plates and 2-hole (2.375" dia) ridge R-purlins using 5/8" x 2" bolts/nuts. Hand tighten the purlin bolt and loosely install the second bolt. The 2.375" dia. 2-hole ridge R-purlins attach to the tab web and bridge plates.

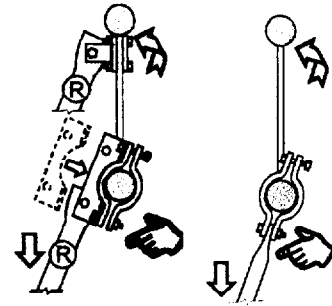

Lower Positions – Attach purlin brackets and add 2-hole S-purlins using 5/8" x 2" bolts/nuts. Hand tighten the purlin bolt and loosely install the second bolt. The 1.66" dia. 2-hole S-purlin goes **between** the two purlin brackets.

3. Elevate the arch as before, allowing the purlins to swing and hang downwards. Secure the arch to the anchor bolts using nuts. **Do not tighten anchor nuts fully.**

F3. INSTALL THE END PURLINS – See Pages 11 and 12.

1. Swing the free end of the 2-hole (1.66" dia) S-purlins up to the brackets on the previously installed arch and attach using 5/8" x 2" bolts/nuts.
2. Swing the free end of the 2-hole (2.375" dia) ridge R-purlins up to the purlin brackets and tab web plates and attach using 5/8" x 2" bolts/nuts.
3. Attach 3-hole X-purlins to the coupler plates as required. Center bolt the purlins together using a 3/8" x 3 1/2" bolt and nut. *You may need to install the center bolt before tightening the 5/8" x 2" bolts.*
4. **Tighten all purlin bolts securely.**

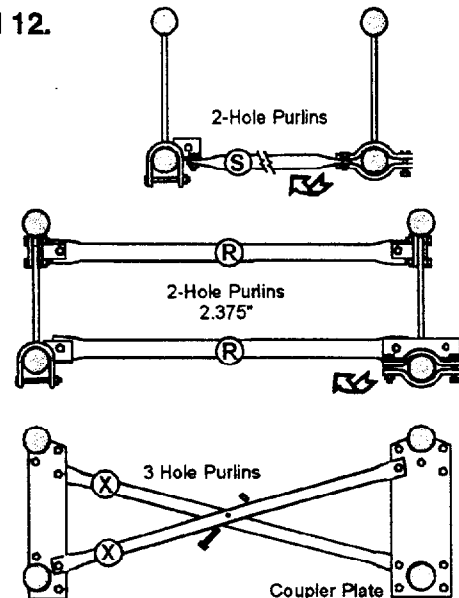

F4. TAPE SADDLE BRACKETS AND RIDGE PURLINS.

1. Duct tape the saddle brackets w/tabs to protect the end wall and the ridge R-purlins to protect the cover during installation.

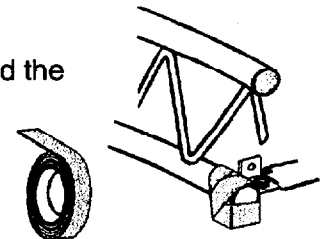

F5. TIGHTEN ANCHOR BOLTS.

1. Tighten all anchor bolts fully on this arch.

F6. HOIST THE THIRD (3) ARCH INTO POSITION.

1. Repeat F2 and F3.
NOTE: Exclude F3, step 3. Only the end bays have 3-hole X-purlins. See diagrams Pages 11 & 12.

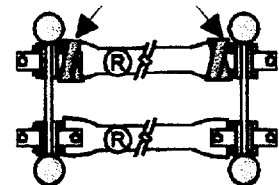

F7. TIGHTEN ANCHOR BOLTS.

Tighten all anchor bolts fully on this arch.

F8. ERECT THE FOURTH (4), FIFTH (5) AND SIXTH (6) ARCH.

Repeat F6, and F7.

F9. CONNECT CROSS CABLES.

1. Locate the four (4) long cables. Attach the turnbuckle end of one cable to the base plate "A" by securing it to an anchor bolt. Use 2 washers.

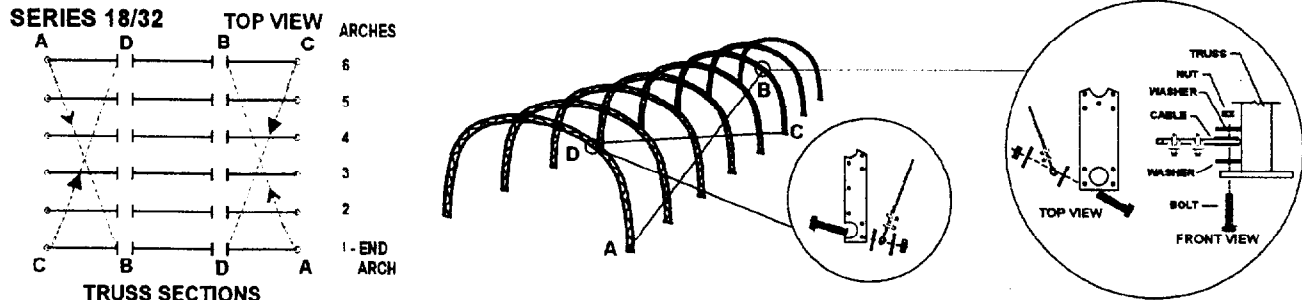

NOTE: Cross cables are connected to both outside arches on buildings less than 50' long.

2. Attach the other end of the cable to the first truss coupler plate of the sixth arch "B" by first threading the cable through trusses 2, 3, 4 & 5 in a direct line. Adjust if cable appears to be misaligned. Secure this end of the cable by first removing a coupler nut and installing a cable thimble between 2 washers and replacing the nut. Loop the end of the cable around the thimble and secure with 2 cable clamps. Retighten the nut.
3. Attach the turnbuckle end of a second cable to the base plate of the sixth arch "C", thread through the middle arches in a direct line, and secure to the first truss 1/2 coupler plate on the end arch "D" using a 5/8" x 2" bolt. Secure using a cable thimble, 2 washers and 2 cable clamps. The cables should cross between the third and fourth arch.
4. Repeat this procedure on the other side using the two remaining long cables.
5. Tighten all turnbuckles so that the cables are taut. Ensure that the building is square and rigid upon completion of this step.

Hint: Depending on the amount of slack in the cable, there may not be enough adjustment to tighten the cables securely. If this occurs, release the turnbuckles and shorten the cable assembly.

F10. ERECT ALL REMAINING ARCHES.

1. Repeat steps F6 and F7 until all remaining arches are erected. *Remember*, the last erected arch (the end arch) has the 1/2 coupler plates.
2. **End Arch** – requires saddle brackets w/tabs and flat web plates. See F1, Page 10. Also requires 3-hole X-purlins installed at the coupler plates See F3, Page 13.

F11. ANCHOR PINS - SERIES 18 ONLY.

1. Drive 2 rebar pins in each truss base plate using a sledge hammer. Place rebar pins in any 2 holes diagonally opposite to the anchor bolts.

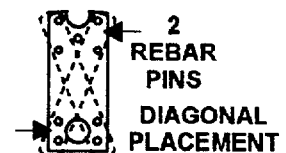

NOTE: The arch cross cables on the first 6 arches B support the entire structure for a building up to 130' in length. It is now safe to remove the end arch bracing.

G - INSTALLING THE FASTENING PIPES

Use a ground sheet to protect the cover while it is being prepared for installation.

1. Mount a lashing winch to an outside anchor bolt at each base plate. Corners A, B, C and D require the winches to be mounted according to the diagram on this page. Make sure that the winch drive nut is accessible when mounting inside truss lashing winches.

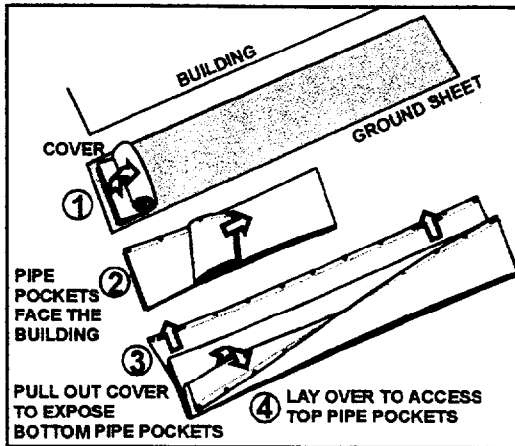
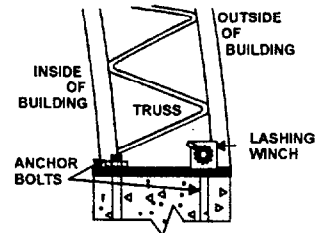
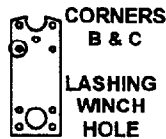
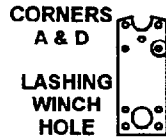

2. Roll out the DURAWEAWE™ cover and leave a small walk area between the cover's edge and the piles. Align the cover evenly to each end of the frame. The notches in the cover line up with every pile.
3. Install both fastening pipes before installing cover.
4. Use 1/4" self-drilling bolts to fasten the tubes together. Wrap with duct tape.

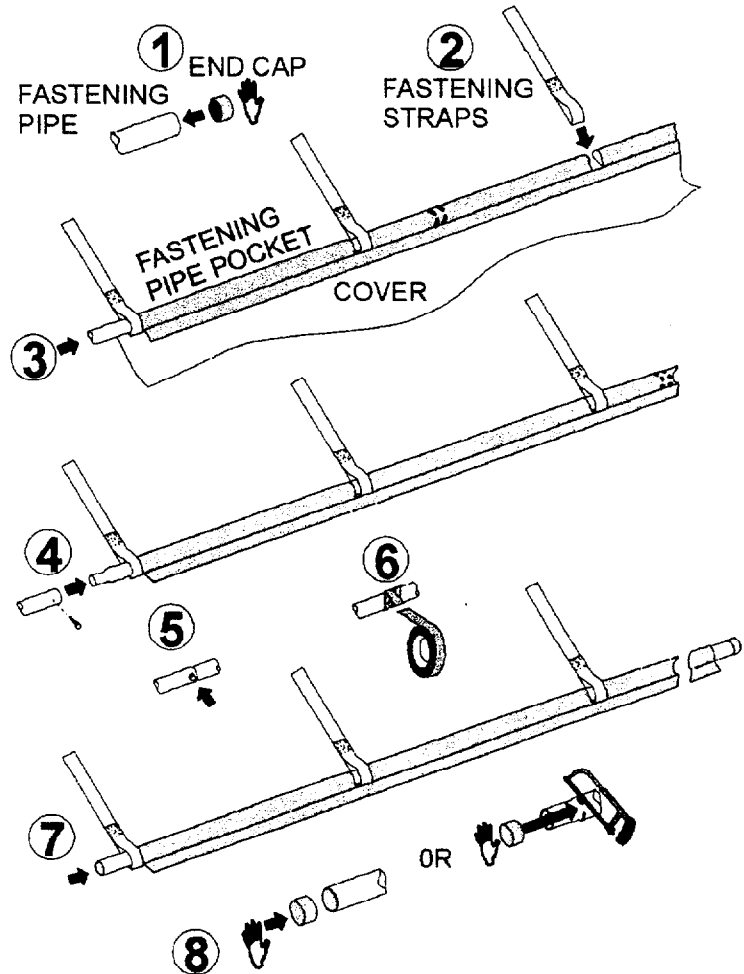

NOTE: Fastening pipes are supplied in 20' lengths. Some buildings will require measured cuts, possibly on two lengths of pipe.

H - INSTALLING THE DURAWEAVE™ COVER

NOTE: *DO NOT install the DURAWEAVE™ cover onto the frame of your Cover-All™ in high wind conditions. A slight breeze is the most advantageous for cover installation. To take advantage of the breeze, pull cover up over the arches with the breeze blowing into the cover . . . like a sail filled with air.*

1. Insert the fastening straps in the lashing winches.
2. On the opposite side of the cover (the side of the cover that is furthest from the frame), tie several ropes, approximately 30 feet apart, to the steel fastening pipe through the notched hole. Throw the free end of the ropes over the frame to the opposite side of the building.

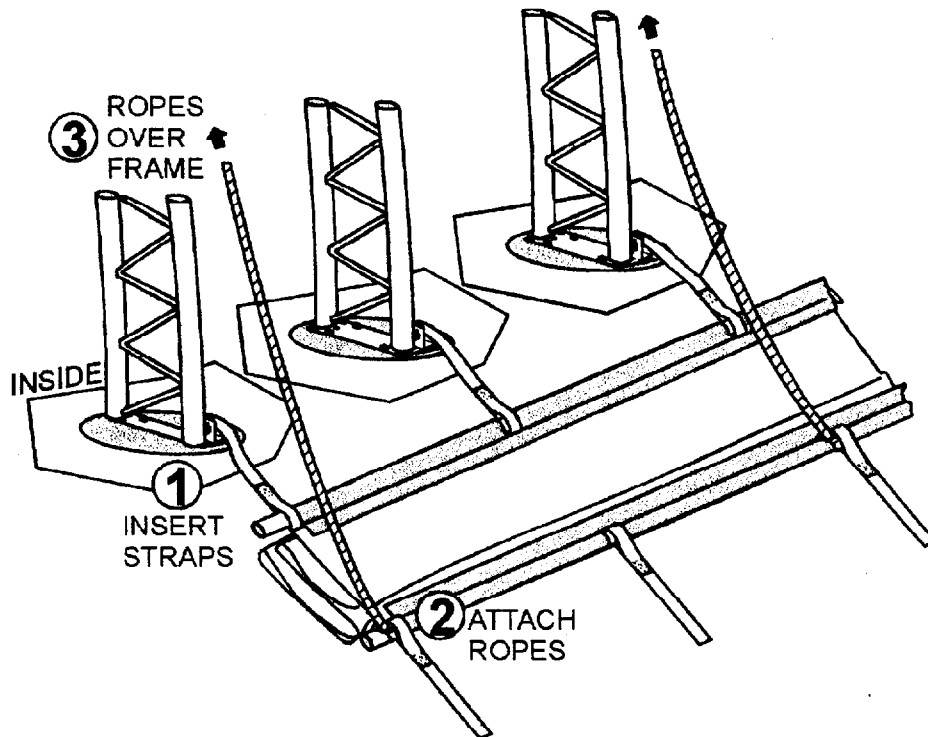

- CHECK LIST:** - **BEFORE** proceeding ensure that: the cover is **POCKET SIDE** up.
- All coupler plates, ridge R-purlins and end arch purlin brackets have duct tape.
 - BOTH fastening pipes are in place.
 - Fastening straps are in the lashing winches.
 - Ropes are secured and passed over the frame.
 - No wind or there can be a light breeze (ideally from rope pulling side).

WARNING: NEVER USE MOTORIZED EQUIPMENT (IE. VEHICLES, TRACTORS, TRUCKS) TO ASSIST IN PULLING THE COVER OVER THE FRAME. OBTAIN ADDITIONAL CREW MEMBERS IF REQUIRED.

3. Pulling on the ropes **EVENLY, CAREFULLY** and **SLOWLY** pull the cover over the frame.
4. Insert fastening straps into lashing winches and **loosely secure**. **DO NOT TIGHTEN**. Adjust the cover so that it is square and evenly centered on the frame. *The end flaps*

NOTE: DO NOT LEAVE THE COVER UNATTENDED UNDER ANY CIRCUMSTANCES until final assembly and tightening has been completed.

I - FINAL ASSEMBLY / TIGHTENING

1. Once the cover is on the frame and is sitting square and straight, visually check to ensure the cover extends approximately 12 inches on both ends of the building.
2. **Glue sections of PVC tubes** together (smooth end into bell end) to fit one PVC pocket.
3. If the PVC pockets have a pull line, drill a hole in the smooth end of the PVC tube and tie the pull line to it. Wrap this leading end with duct tape.
4. Push and pull the PVC through the pockets until the entire pocket contains the PVC tube. Repeat this step for the opposite end of the cover.

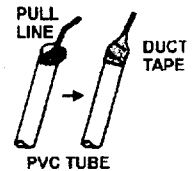

Hint: PVC tubes should slide in easily. Do not force. Check for twisted fabric or misaligned pocket openings if you experience difficulty when installing the tube.

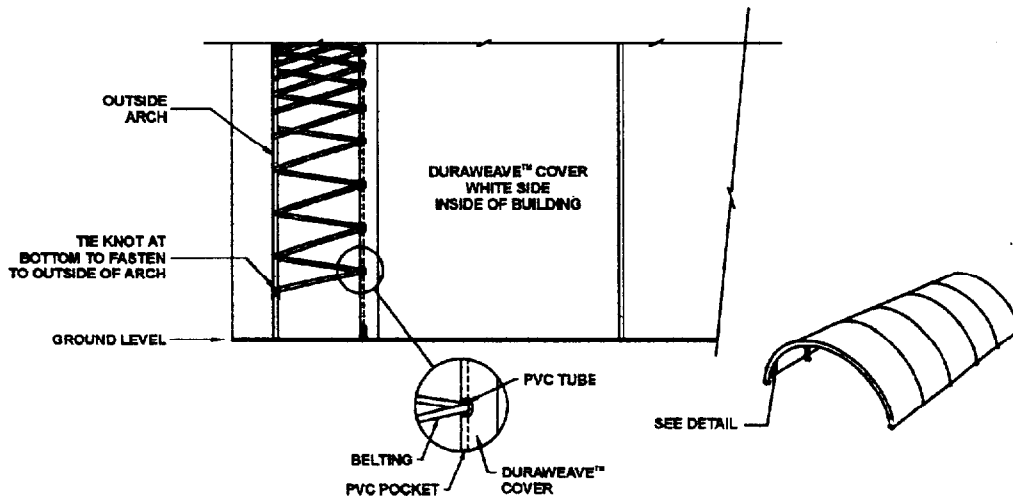

5. Using the 1" belting provided and starting at the base, lace the belting around the PVC tube showing through the notches and then back to the top tube of the end arch all the way up to the top center of the building. Secure the belting to the top arch tube. Working your way down from the secured end, tighten the belting and tie at the base. Repeat this lace-up and tighten-down for the other side. The PVC pipe should be parallel with the end arch all the way around.

- Repeat Step 3 at the opposite end of the building using force to tighten down the belting. The DURAWEAVE™ cover should be taut and secure from end to end when finished.

Hint: *Cut the belting after you have finished the tighten-down procedure and secured the end.*

- Attach a ratchet to the base of each end arch by first removing an anchor bolt nut. Place the D-ring so that it encircles the anchor bolt. Secure the D-ring by replacing and tightening the nut. Add a washer if necessary



ESS

If you are installing an ESS end at this time do not tighten the end flaps now. Tighten the cover and proceed with ESS installation.

- Insert the end flap belting into the ratchets and use the ratchets to tighten both sides of the building's end flaps until the slack in the flap is gone. Repeat tightening procedure for the opposite end of the building. *It may be necessary* to release the mechanism and pull the belting as tight as possible by hand before ratcheting.

J - TIGHTENING THE COVER

- It is now safe to remove all ropes used to steady the frame and install the cover.
- Tighten the fastening straps on both sides of the building **EXCEPT THE END STRAPS** using a torque wrench. Then tighten the end straps until the fastening pipes are level. The tension for the lashing winches on this building has been calculated at **25 - 35** ft. lbs. **DO NOT EXCEED 35** ft. lbs. *Use a torque wrench.* The DURAWEAVE™ cover should be tight and secure from side to side when finished.

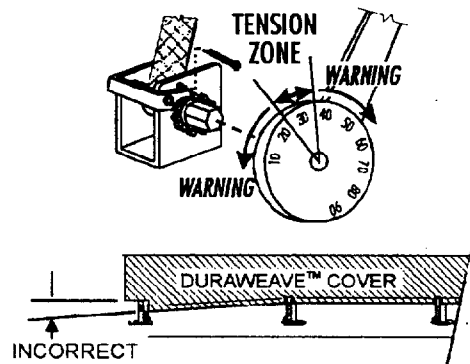

3. **IMPORTANT FINAL STEPS**

Complete the following after the building is erect, roof is installed and tensioned, all purlins including the ridge purlins, and all cross cables and are installed and adjusted.

- **Secure** the outside (end) fastening straps (4) to the fastening pipes **through the strapping.** using 1/4" self-drilling bolts and pipe clips

- **Install** a cotter pin in the lashing winch pilot holes to lock the release lever.

- **Secure** the apron. Suggested methods include: screwing the apron to the frame; securing pipe or dimensional lumber to weigh down the bottom edge; back filling.



IMPORTANT FINAL STEPS - continued

- **Apply** LOCTITE 242 or 243 Medium Strength (blue) Threadlocker (or equivalent) according to the manufacturer's directions, on the engaged threads of every turnbuckle. IF FOR ANY REASON A TURNBUCKLE NEEDS TO BE ADJUSTED – ALWAYS RE-APPLY LOCTITE.

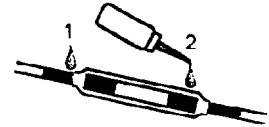

NOTE: Failure to secure the corner fastening straps to the pipe could result in possible damage to the cover.

APPENDIX A

VENT FRAME

1. Measure and mark purlin bracket locations according to the fan housing vertical dimension.
2. Attach the purlin brackets and vent tabs to the outside ESS verticals using 5/8" x 2" bolts/nuts. Place a 3/4" nut spacer between the bracket and vent tabs.
3. Sleeve the horizontal tubes and lift into position.
4. Secure the horizontal tubes to the vent tabs using 5/8" x 2" bolts/nuts.
5. Install 3 of Tek#3 screws at each horizontal sleeve.

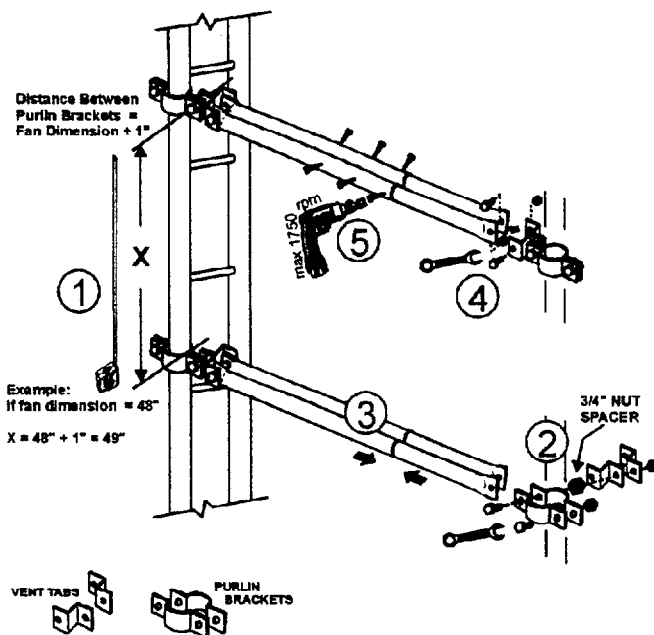

TOP VIEW ASSEMBLY

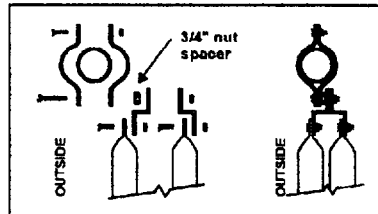

APPENDIX B

BUILDINGS OVER 130' IN LENGTH

Multiple covers are provided for buildings over 130' in length. This enables ease of onsite handling and installation. Normally covers are supplied in equal or near equal lengths. The longest cover length is 130'.

Eg. - a 150' building with 10' spacing is supplied with one 70' and one 80' cover.

1. FOUNDATION

1. Foundation spacing (running measurement) is the same for the entire length of the building. (the covers share a common arch)

Eg. - 150' building on 10' centers has 16 piles/posts on each side.

2. JOINER BRACKET INSTALLATION

1. Install a joiner bracket to the common arch. The bracket installs under the lashing winch on the anchor bolts.

Add end flap ratchets for the end flap belting to each end of the bracket using 5/8" x 2" bolts/nuts.

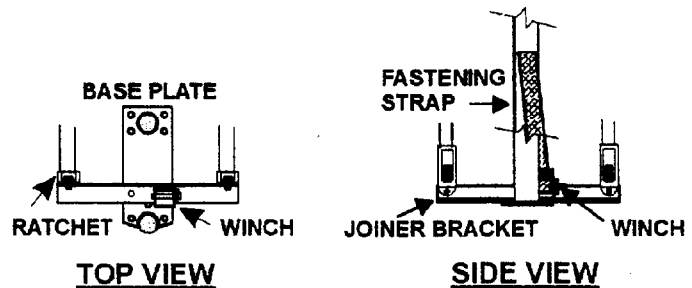

3. CROSS CABLE INSTALLATION

1. Buildings over 130' require 4 sets of 3/16" X 60' cross cables. Install 2 sets of cables at each end of the completed building.

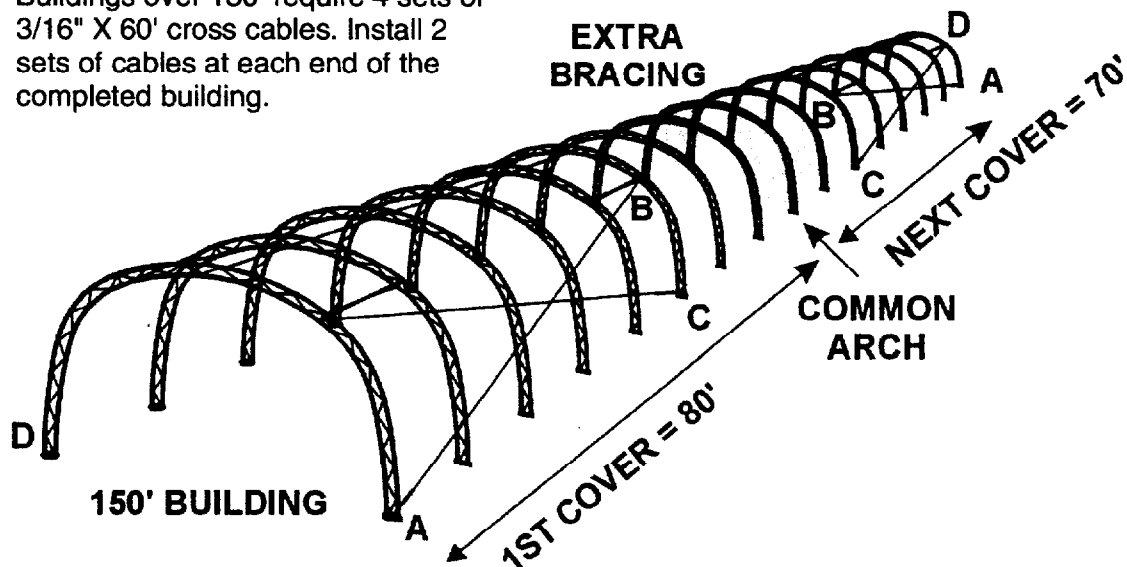

4. EXTRA BRACING

Extra bracing is added to 2 bays, one on each side of a common arch.

1. Add extra purlin bracing according to your building. Typically this bracing duplicates the end bay bracing.

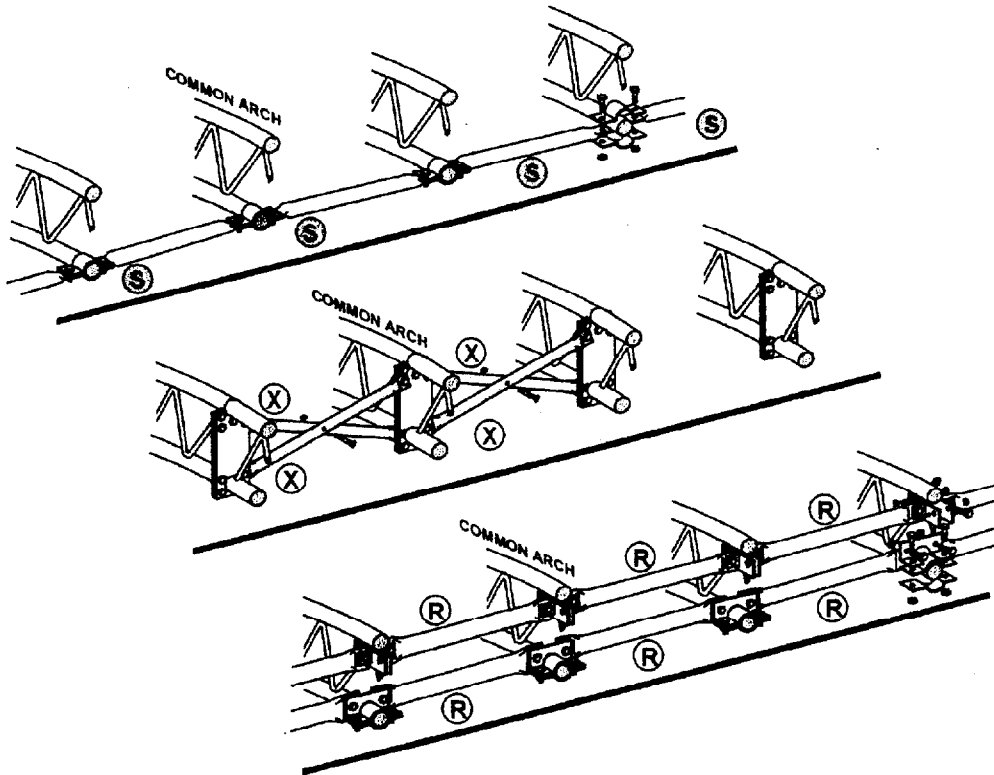

5. COVER INSTALLATION

1. Install the first cover and as directed in Sections G, H, I and J (Pages 15-18), *except that* the end flap on the common arch is *not* secured at this time. Flip the end flap back and out of the way.
2. Install the next cover in the same manner, *lacing the PVC tube to the common arch*. Do not tighten the lashing winches of this cover at this time.
3. Release the fastening strap in the end arch winch of the first building. Insert the swaged fastening pipe sleeves to join the fastening pipe of both covers and secure with self-drilling bolts. Place the fastening strap over the sleeve and re-install the end fastening strap in the winch. Retighten this lashing winch and tighten all of the winches of the next cover. See Section J, Page 18 for torque specifications.

4. Place the end flap of the first cover over the next cover's lacing (see note). Attach the belting for this first (inner) end flap to the ratchets. Tighten the ratchets.
5. Place the end flap (outer) of the next cover over the first (inner) end flap. Cut a slit in the first (inner) end flap at the point where the fastening strap for the outer end flap exits its pocket. Feed the fastening strap through the slit and attach to the ratchets. Tighten the ratchets/winches.
6. Apply a bead of silicone (supplied) between the outer end flap and the cover. Insert the tube tip between the layers with all straps fastened securely. Walk on the building to seal the top portion of the end flap and use a ladder or lift equipment to reach the sides. Where it is difficult to reach some areas, unsealed portions should not exceed 3 feet.

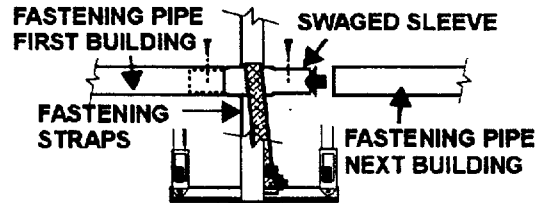

NOTE: If your building is subject to prevailing winds, you should secure the end flaps to protect the overlap.

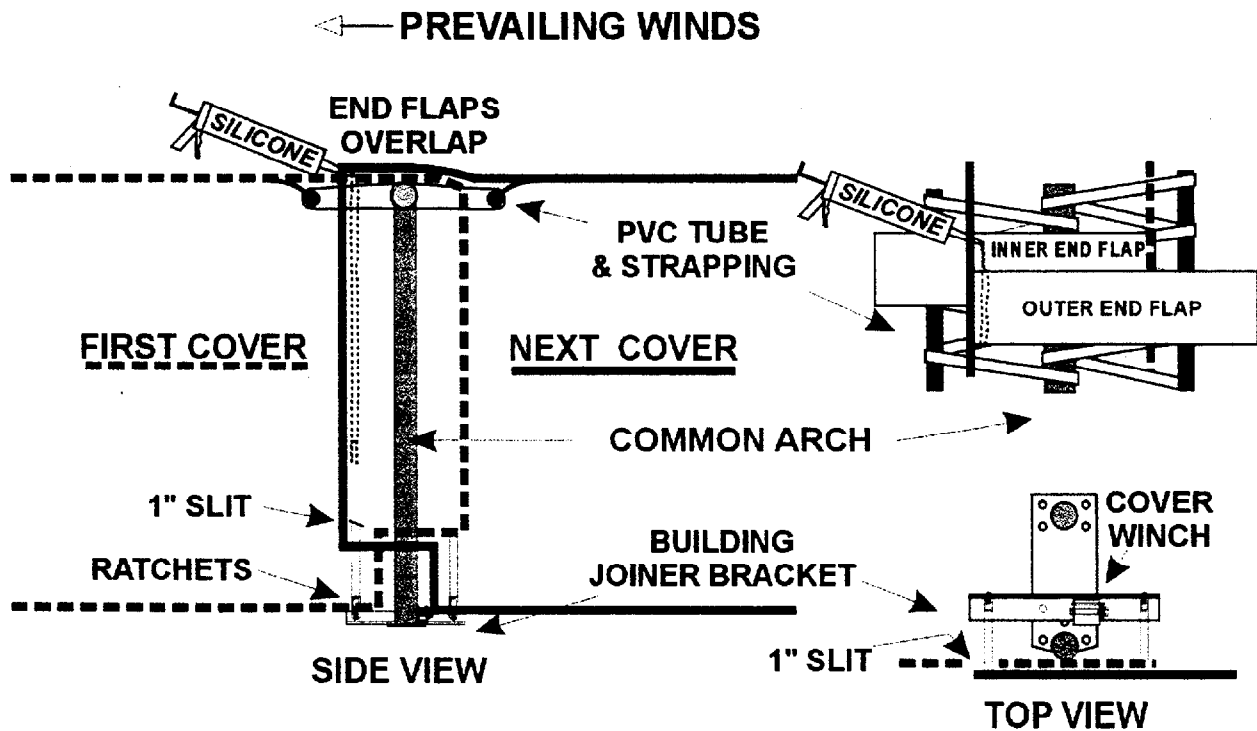

SQUARING A FOUNDATION

IMPORTANT

Depending on the size of your building, you may need a qualified contractor or engineer to lay out the foundation of your building to ensure that it is straight and square.

The following is a suggested method only.

Cover-All Building Systems™ is not responsible for foundations.

1. Measure and string a straight line the exact length of the building (D1-D2).
2. Attach a measuring tape to stake D2 and measure the exact width of the building perpendicular to line D1-D2. Make an arc in the dirt at that exact measurement. Repeat this procedure at stake D1 and make a second arc.
3. String an extended line (D3-D4) at the crowns of these two arcs. Recheck width measurements.

USING THE 3-4-5 METHOD TO SQUARE THE FOUNDATION

4. With the measuring tape still attached to stake D1, measure the distance ($4 \times Y$) from stake D1 towards stake D2 and place a stake (M1). See chart this page for a suggested value for Y for your building.
5. With the measuring tape still attached to stake D1, measure the distance ($3 \times Y$) through the crown of the arc, and past line D3-D4, to M2.
6. With a second tape attached to stake M1, measure the distance ($5 \times Y$) to M2.
7. Keeping the tapes tight, cross the two tapes at exactly the ($3 \times Y$) measurement and the ($5 \times Y$) measurement and hold in position. Place a stake (D6) exactly where line D1-M2 crosses line D3-D4. Remove stake M2.
8. Follow the linear and diagonal measurement checks on Page 6 of this manual.

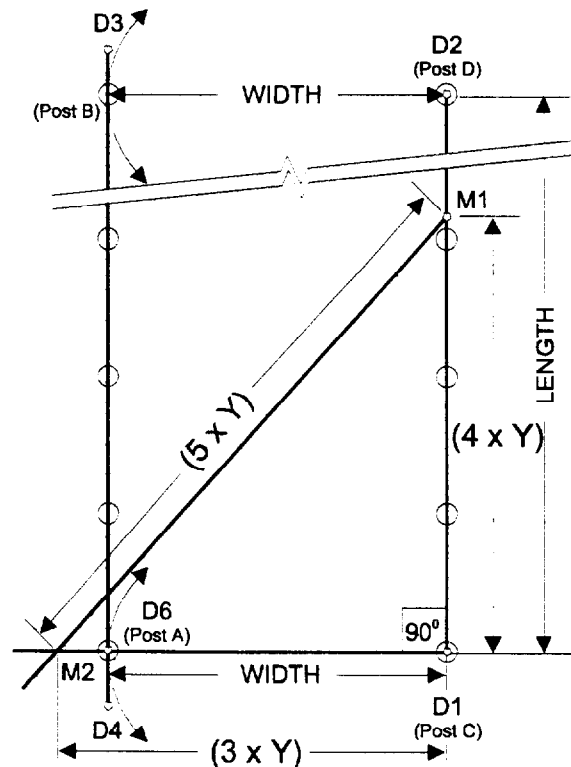

| SERIES | SIZE | SUGGESTED Y VALUE |
|--------|-------|-------------------|
| SAS | 20 | 7' |
| | 22 | 8' |
| | 26 | 9' |
| | 30 | 11' |
| TAS | 18 | 7' |
| | 30/32 | 11' |
| | 42 | 15' |
| | 40 | 14' |
| | 50 | 17' |
| | 55 | 19' |
| | 62 | 22' |
| | 72 | 25' |

LIMITED WARRANTY
DURAWEAWE™ AND DURAWEAWE™ FR ("FIRE RETARDANT")



1. Scope of Limited Warranty

Only the DURAWEAWE™ and DURAWEAWE™ FR cover, end enclosure and DURATRAC and DT/LS fabric portion of the Cover-All™ building described in this agreement are warranted to the original Customer/Purchaser against deterioration that hampers the effectiveness of the cover caused by UV rays, hail and to be free of defects in materials and workmanship under normal use. This warranty shall be effective only if and when a) Cover-All Building Systems™ has received a completed warranty registration within 60 days after installation of the Cover-All™ building; and b) Cover-All Building Systems™ receives notice of such defect during the period of the warranty. Replacement of the cover and/or end enclosure or any components thereof (the "Warranted Parts"), supplied under this warranty may be new, used or repaired, at the option of Cover-All Building Systems™. The Customer's/ Purchaser's sole remedy shall be such repair or replacement as is expressly provided above. Any Warranted Parts of the Cover-All™ building repaired or replaced under this warranty are subsequently warranted only for the remaining unexpired portion of the warranty period applicable to the original product. If Cover-All Building Systems™ elects to repair or replace the defective product or component, Cover-All Building Systems™ shall have a reasonable time to do so.

DURAWEAWE™ Main Building Cover Warranty

The DURAWEAWE™ cover is warranted, under normal use and maintenance in accordance to the instruction manual, to the original Customer/Purchaser for a period of 15 years following the original date of purchase. In the event that the DURAWEAWE™ cover needs to be replaced, the Customer/Purchaser would be held responsible for the cost at 1/15 or 6.66% of the current retail price for each year following the original date of purchase. In the event that the DURAWEAWE™ cover needs to be repaired, the cost of the repair will be prorated by Cover-All Building Systems™. A cover repaired under this warranty is subsequently warranted for only the unexpired portion of the original warranty period. The replacement cover, if required, will be made available at the nearest authorized Cover-All Building Systems™ Dealer.

DURAWEAWE™ FR ("Fire Retardant") Main Building Cover Warranty

The DURAWEAWE™ FR cover is warranted, under normal use and maintenance in accordance to the instruction manual, to the original Customer/Purchaser for a period of 10 years following the original date of purchase. In the event that the DURAWEAWE™ FR cover needs to be replaced, the Customer/Purchaser would be held responsible for the cost at 1/10 or 10% of the current retail price for each year following the original date of purchase. In the event that the DURAWEAWE™ FR cover needs to be repaired, the cost of the repair will be prorated by Cover-All Building Systems™. A cover repaired under this warranty is subsequently warranted for only the unexpired portion of the original warranty period. The replacement cover, if required, will be made available at the nearest authorized Cover-All Building Systems™ Dealer. DURAWEAWE™ and DURAWEAWE™ FR ("Fire Retardant") End Enclosure Warranty. The DURAWEAWE™ and DURAWEAWE™ FR end enclosures are warranted, under normal use and maintenance in accordance with the instruction manual, to the original Customer/Purchaser for a period of 3 years following the original date of purchase.

FIRST YEAR: Should the end enclosure be found to have manufacturer defects within the first year following purchase by the Customer/Purchaser, the defect(s) will be, at the option of Cover-All Building Systems™, repaired or replaced at no cost to the Customer/Purchaser except for delivery costs of the Warranted Parts to the Customer/Purchaser, which shall be the sole responsibility of the Customer/Purchaser.

SECOND YEAR: Should the end enclosures be found to have manufacturer defects within the second year following purchase by the Customer/Purchaser, the defect(s) will be, at the option of Cover-All Building Systems™, repaired or replaced. The Customer/Purchaser shall be responsible for thirty-three (33%) percent of the repair or replacement costs plus the cost of delivery of the Warranted Parts to the Customer, which shall be the sole responsibility of the Customer/Purchaser.

THIRD YEAR: Should the end enclosure be found to have manufacturer defects within the third year following purchase by the Customer/Purchaser, the defect(s) will be, at the option of Cover-All Building Systems™, repaired or replaced. The Customer/Purchaser shall be responsible for sixty-six (66%) percent of the repair or replacement costs plus the cost of delivery of the Warranted Parts to the Customer/Purchaser, which shall be the sole responsibility of the Customer/Purchaser.

DURATRAC and DT/LS DURAWEAWE™ and DURAWEAWE™ FR ("Fire Retardant") Door Fabric Warranty

The DURATRAC and DT/LS DURAWEAWE™ and DURAWEAWE™ FR door fabric is warranted for one year, under normal use and maintenance in accordance with the instruction manual, to the original Customer/Purchaser, the defect(s) will be, at the option of Cover-All Building Systems™, repaired or replaced at no cost to the Customer/Purchaser except for delivery costs of the Warranted Parts to the Customer/Purchaser which shall be the sole responsibility of the Customer/Purchaser. The warranted parts, if required, will be made available at the nearest authorized Cover-All Building Systems™ Dealer.

This warranty contains the sole expressed warranty of Cover-All Building Systems™. There are no other warranties, expressed or implied. This warranty is made in lieu of any implied warranties of merchantability or fitness for a particular purpose. Specifications and warranties are applicable to units sold in Canada, the United States, its territories and possessions, and may vary outside these areas.

2. Limits and Release of Liability

This warranty does not apply to defects or damage resulting from a) installation that is improper and/or not in accordance with the instruction manual; b) improper or inadequate maintenance; c) modification or alteration of the product; d) neglect, misuse or abuse of product; e) accident; f) unauthorized repair or alteration; g) integration with other products or accessories not manufactured specifically for use with the Cover-All™ building; h) exposure to corrosive elements; i) exposure to conditions in excess, or not meeting, as the case may be, the wind and snow load specifications of each building model (check with our engineering dept.); j) foundation design and/or installation and/or deficiency in the foundation; k) product upgrades; l) product recall; or m) an act of God. This warranty shall not apply to any products not manufactured by Cover-All Building Systems™. No one is authorized to change or add to this warranty. Cover-All Building Systems™ shall not be liable for any damages incurred during or as a result of installation of Cover-All Building Systems™ product, whether or not in accordance with the instruction manual. This warranty gives you specific legal rights. You may also have other rights which vary from jurisdiction to jurisdiction. In no event shall Cover-All Building Systems™, any distributor, or the selling dealer be liable for any direct, indirect, special incidental or consequential damages (including loss of profits, loss of time, inconvenience, or the use or inability to use this product for any purpose whatsoever), whether based on contract, tort, strict liability or any other legal basis; even if Cover-All Building Systems™, its distributor, or selling dealer was advised of the possibility of the occurrence of such damages. The Customer/Purchaser expressly releases and discharges Cover-All Building Systems™, all distributors, and all dealers from all claims, demands, actions, suits, judgments and executions for any actual, incidental or consequential damages, bodily or otherwise, that the Customer/Purchaser ever had, now has, or may have created by arising out of the assembly, erection, use and/or operation of any Cover-All™ building. All references to Customer's/Purchaser's, Cover-All Building Systems™, all distributors and all dealers, include such parties' spouse, heirs, successors, legal representatives and assigns.

LIMITED WARRANTY - STEEL



1. Scope of Limited Warranty

Only the steel framework, end support systems and DURATRAC and DT/LS door tubes and steel fabricated parts of the Cover-All™ building described in this agreement are warranted to the original Customer/Purchaser to be free of defects in materials and workmanship under normal use. This warranty shall be effective only if and when a) Cover-All Building Systems™ has received a completed warranty registration within 60 days after installation of the Cover-All™ building; and b) Cover-All Building Systems™ receives notice of such defect during the period of the warranty. Replacement framework or any components thereof (the "Warranted Parts"), supplied under this warranty may be new, used or rebuilt, at the option of Cover-All Building Systems™. The Customer's/Purchaser's sole remedy shall be such repair or replacement as is expressly provided above. Any Warranted Parts of the Cover-All™ building repaired or replaced under this warranty are subsequently warranted only for the remaining unexpired portion of the warranty period applicable to the original product. If Cover-All Building Systems™ elects to repair or replace the defective product or component, Cover-All Building Systems™ shall have a reasonable time to do so.

Steel Framework (main arches and end support system)

The steel main arches and steel end support systems are warranted, under normal use and maintenance in accordance with the instruction manual, to the original Customer/Purchaser for a period of 3 years following the original date of purchase.

FIRST YEAR: Should the Warranted Parts be found to have manufacturer defects within the first year following purchase by the Customer/Purchaser, the defect(s) will be, at the option of Cover-All Building Systems™, repaired or replaced at no cost to the Customer/Purchaser except for delivery costs of the Warranted Parts to the Customer/Purchaser, which shall be the sole responsibility of the Customer/Purchaser. The Warranted Parts, if required, will be made available at the nearest authorized Cover-All Building Systems™ Dealer.

SECOND YEAR: Should the Warranted Parts be found to have manufacturer defects within the second year following purchase by the Customer/Purchaser, the defect(s) will be, at the option of Cover-All Building Systems™, repaired or replaced. The Customer/Purchaser shall be responsible for thirty-three (33%) percent of the repair or replacement costs plus the cost of delivery of the Warranted Parts to the Customer/Purchaser. The Warranted Parts, if required, will be made available at the nearest authorized Cover-All Building Systems™ Dealer.

THIRD YEAR: Should the Warranted Parts be found to have manufacturer defects within the third year following purchase by the Customer/Purchaser, the defect(s) will be, at the option of Cover-All Building Systems™, repaired or replaced. The Customer/Purchaser shall be responsible for sixty-six (66%) percent of the repair or replacement costs plus the cost of delivery of the Warranted Parts to the Customer/Purchaser. The Warranted Parts, if required, will be made available at the nearest authorized Cover-All Building Systems™ Dealer.

DURATRAC and DT/LS Doors

The DURATRAC and DT/LS door tubes and steel fabricated parts (the "Warranted Parts") are warranted, under normal use and maintenance in accordance with the instruction manual, to the original Customer/Purchaser for a period of 1 year following the original date of purchase. Should the Warranted Parts be found to have manufacturer defects within the first year following purchase by the Customer/Purchaser, the defect(s) will be, at the option of Cover-All Building Systems™, repaired or replaced at no cost to the Customer/Purchaser except for delivery costs of the Warranted Parts to the Customer/Purchaser which shall be the sole responsibility of the Customer/Purchaser. The warranted parts, if required, will be made available at the nearest authorized Cover-All Building Systems™ Dealer. All mechanical and moving parts carry an OEM Manufacturer warranty of one year.

This warranty contains the sole expressed warranty of Cover-All Building Systems™. There are no other warranties expressed or implied. This warranty is made in lieu of any implied warranties of merchantability or fitness for a particular purpose. Specifications and warranties are applicable to units sold in Canada, the United States, its territories and possessions and may vary outside these areas.

2. Limits and Release of Liability

Refer to Limits and Release of Liability in LIMITED WARRANTY - DURAWEAWE™ AND DURAWEAWE™ FR ("FIRE RETARDANT").

6/98

CONVERSIONS

| INCHES | | MILLIMETERS | |
|--------|-------|-------------|------|
| 1/32" | | | |
| 2/32 | 1/16" | | 1.6 |
| 3/32 | | | |
| 4/32 | 2/16 | 1/8" | 3.2 |
| 5/32 | | | |
| 6/32 | 3/16" | | 4.8 |
| 7/32 | | | |
| 8/32 | 4/16 | 2/8 | 1/4" |
| | 5/16 | | 6.4 |
| | 6/16 | 3/8" | 9.5 |
| | 7/16 | | |
| | 8/16 | 4/8 | 2/4 |
| | 9/16 | | 12.7 |
| | 10/16 | 5/8" | 15.9 |
| | 11/16 | | |
| | 12/16 | 6/8 | 3/4" |
| | 13/16 | | 19.0 |
| | 14/16 | 7/8" | 22.2 |
| | 15/16 | | |
| | 16/16 | 8/8 | 4/4 |
| | | 2/2 | 1" |
| | | | 25.4 |

BOLT TORQUE

1 ft. lb. = 1.356 N.m

VOLUME

1 CUBIC YARD
= .77 M³
1 CUBIC FOOT
= .03 M³

| FEET | METERS |
|------|--------|
| 1' | .305 |
| 2 | .610 |
| 3 | .914 |
| 4 | 1.219 |
| 5 | 1.524 |
| 6 | 1.829 |
| 7 | 2.134 |
| 8 | 2.438 |
| 9 | 2.743 |
| 10 | 3.048 |
| 25 | 7.620 |
| 30 | 9.144 |
| 35 | 10.668 |
| 40 | 12.192 |
| 45 | 13.716 |
| 50 | 15.240 |
| 60 | 18.288 |
| 70 | 21.336 |
| 80 | 24.384 |
| 90 | 27.432 |
| 100' | 30.480 |

Building Components
continued



DURAWEAWE™ COVER(S)

PVC GLUE 804520 1.4 #

3/8" MAG CHUCK DRIVER 804100

LOCTITE 242 - .5ml

123456

DUCT TAPE

804500

1" BELTING

804540

1.22 #

1.71 #

1.70 #

11.2 #

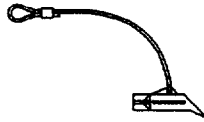

#88 DUCKBILL ANCHOR/CABLE ASSEMBLY (LOOPED END)

805050

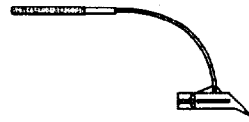

#88 DUCKBILL ANCHOR/CABLE ASSEMBLY (BOLT END)

304490

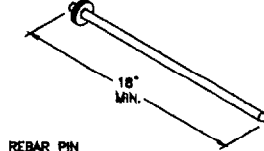

REBAR PIN ASSEMBLY

340020

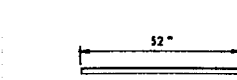

#88 DUCKBILL DRIVE ROD

340050

Buildings Over 130'

0.27 #

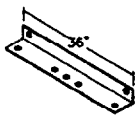

BUILDING JOINER BRACKET

322015

SILICONE 804525



FASTENING TUBE SLEEVE SWAGED

313191

SUGGESTED ASSEMBLY TORQUE VALUES FOR STRUCTURAL BOLTS

| SIZE DIA (INCH) | THREADS PER INCH | GRADE 5 ft - lbs | |
|-----------------|------------------|------------------|-----|
| | | DRY | WET |
| 3/8 | 16 | 30 | 23 |
| 7/16 | 14 | 50 | 35 |
| 1/2 | 13 | 75 | 55 |
| 5/8 | 11 | 150 | 110 |
| 3/4 | 10 | 260 | 200 |
| 1 1/4 | 7 | 1120 | 840 |

SUGGESTED ASSEMBLY TORQUE VALUES FOR STRUCTURAL BOLTS

| SIZE DIA (INCH) | THREADS PER INCH | GRADE 5 ft - lbs | |
|-----------------|------------------|------------------|-----|
| | | DRY | WET |
| 3/8 | 16 | 30 | 23 |
| 7/16 | 14 | 50 | 35 |
| 1/2 | 13 | 75 | 55 |
| 5/8 | 11 | 150 | 110 |
| 3/4 | 10 | 260 | 200 |
| 1 1/4 | 7 | 1120 | 840 |



TEMPLATE

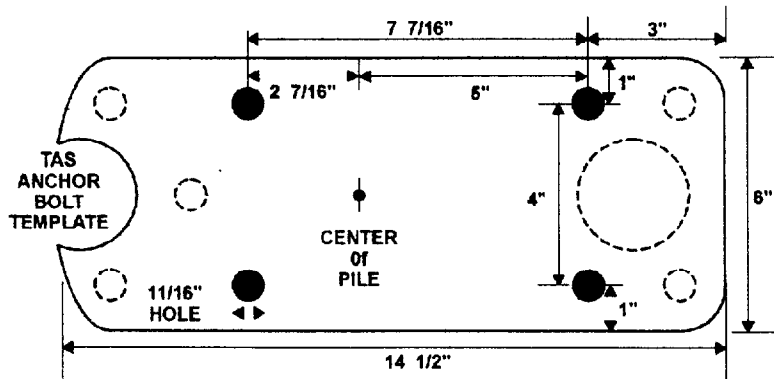

END ARCH

This side to outside of building.

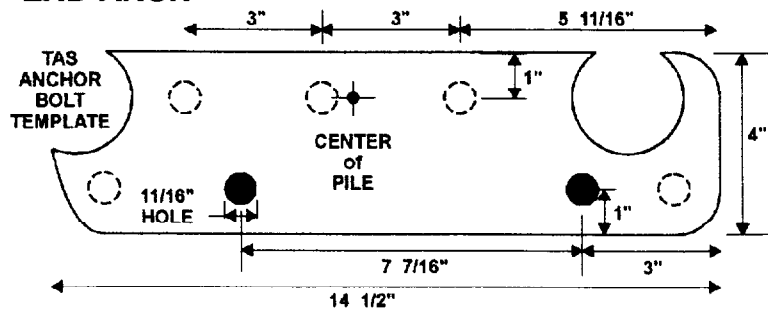

FOR TECHNICAL ASSISTANCE CALL YOUR LOCAL DEALER OR SALES REPRESENTATIVE OR 1-800-268-3768

Manufactured
in Canada

COVER-ALL
BUILDING SYSTEMS

2201 Speers Avenue, Saskatoon, SK Canada S7L 5X6
www.coverall.net

 WELDING
CERTIFICATION
For Fusion Welding
Of Steel Structures

Printed in Canada

No part of the contents of this manual may be reproduced or transmitted in any form or by any means without the written permission of Cover-All Building Systems™. TITAN, TALON, Cover-All, DURAVEAVE and WinchLoc are trademarks of Cover-All Building Systems™.

Applicant: Tony Lombardo - Public Works Date: 11/13/01
Address: 71 Hamner St C-B-L: 34-H-4

CHECK-LIST AGAINST ZONING ORDINANCE

Date - NEW Bldg permit # 01-1393
Zone Location - B-5
Interior or corner lot -
Proposed Use/Work - Public Works - 2 salt sheds - foundation only permit
Sewage Disposal - would be City - No service provided
Lot Street Frontage - Nm requ.
Front Yard -
Rear Yard - } None req.
Side Yard - }
Projections -
Width of Lot - N/A
Height - 65' MAX
Lot Area - None req. -
Lot Coverage/ Impervious Surface - 100% allowed
Area per Family - N/A
Off-street Parking - Non Req.
Loading Bays -
Site Plan - Minor # 2001-0273
Shoreland Zoning/ Stream Protection - N/A
Flood Plains - Panel 13 Zone C