

1 BITUMINOUS PAVEMENT- PARKING LOT
5 NOT TO SCALE

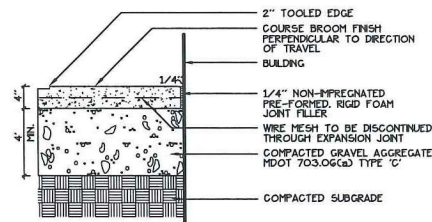

6 CONCRETE SLAB
5 NOT TO SCALE

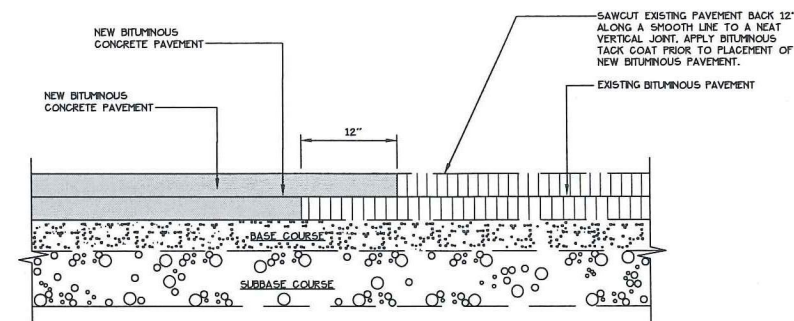

11 PAVEMENT SAWCUT DETAIL
5 NOT TO SCALE

NOTE: BRICK SIDEWALKS IN CITY OF PORTLAND RIGHT-OF-WAY SHALL BE FINE HALL PATHWAY PAVEMENT. LAGHANCE ITEM #545623

NOTE: SLOPE 0.02 TYPICAL TOWARD CURB.

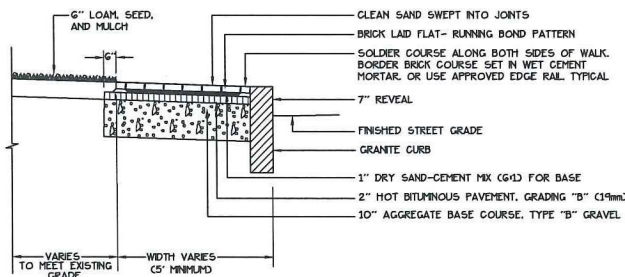

2 BRICK SIDEWALK WITH BITUMINOUS BASE AND GRANITE CURB
5 NOT TO SCALE

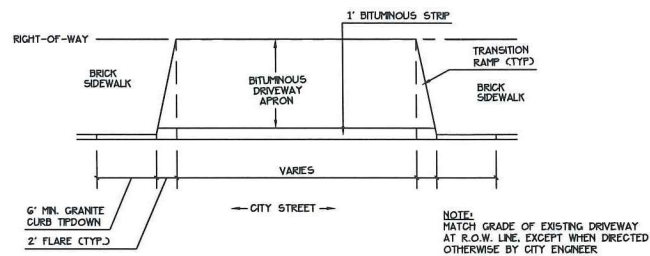

7 DRIVEWAY APRON LAYOUT
5 NOT TO SCALE

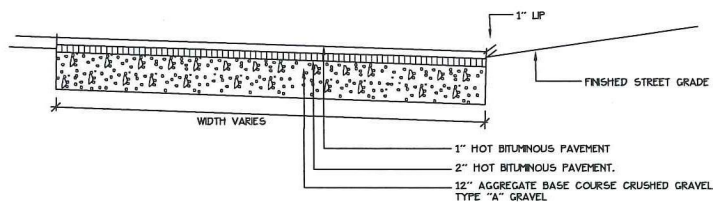

3 BITUMINOUS DRIVEWAY APRON
5 NOT TO SCALE

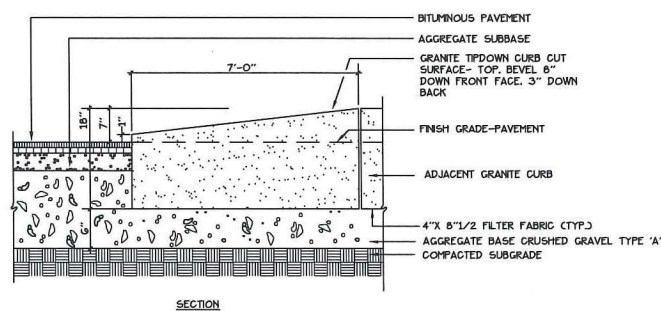

8 GRANITE TIP-DOWN CURB
5 NOT TO SCALE

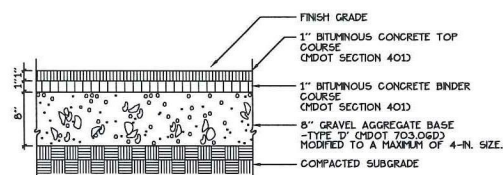

4 BITUMINOUS SIDEWALK
5 NOT TO SCALE

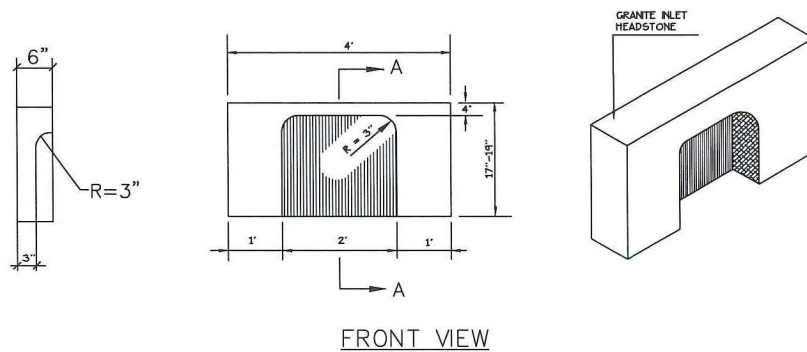

9 4" GRANITE HEADSTONE FOR CURB INLET
5 NOT TO SCALE

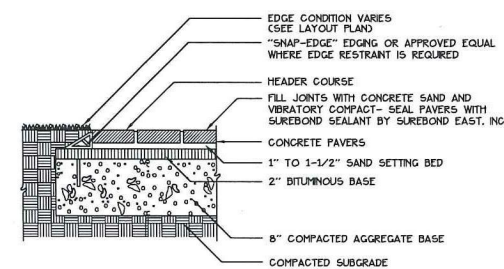

NOTE: PAVERS SHALL BE SEALED WITH SUREBOND SB-1370 JOINT STABILIZING SEALER OR APPROVED EQUAL

MANUFACTURER: GENEST CONCRETE WORKS, INC. OR APPROVED EQUAL

5 CONCRETE PAVERS
5 NOT TO SCALE

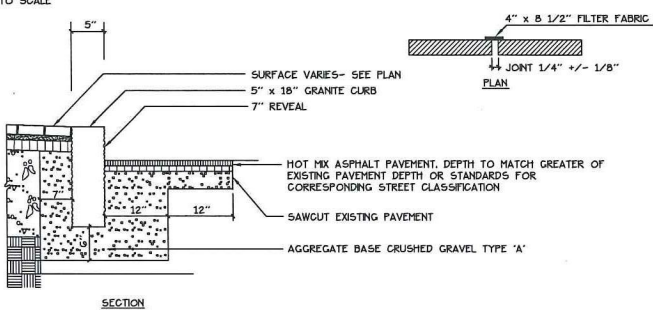

10 VERTICAL GRANITE CURB
5 NOT TO SCALE

12 BIKE RACK
5 NOT TO SCALE

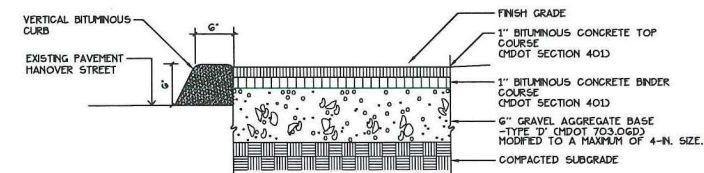

13 TEMPORARY BITUMINOUS SIDEWALK-HANOVER STREET
5 NOT TO SCALE

Prepared For:
Applicant:
BoPo, L.L.C.
58 Alder Street
Portland, Maine
Justin Alford, Manager

Prepared By:
MITCHELL & ASSOCIATES
Landscape Architects
The Staples School
70 Center Street
Portland, Maine 04101
Tel: (207) 774-4427

BAYSIDE BOWL
Portland, Maine
58 Alder Street

Date:
DECEMBER 18, 2015

Issued For:
AMENDED
SITE PLAN SUBMISSION

Revisions:

Reproduction or reuse of this document without the expressed written consent of Mitchell & Associates is prohibited.



CITY OF PORTLAND
APPROVED SITE PLAN

Subject to Conditions of Approval
and Standard Conditions

DATE of APPROVAL: 6/9/15

PLANNER: Richard Knowland
PROJECT NO. # 2015-230

North
Sheet No. 5