

3/4"=1'-0 **L** DETAIL  
 S2.2  
**TYPICAL CORNER PILASTER**

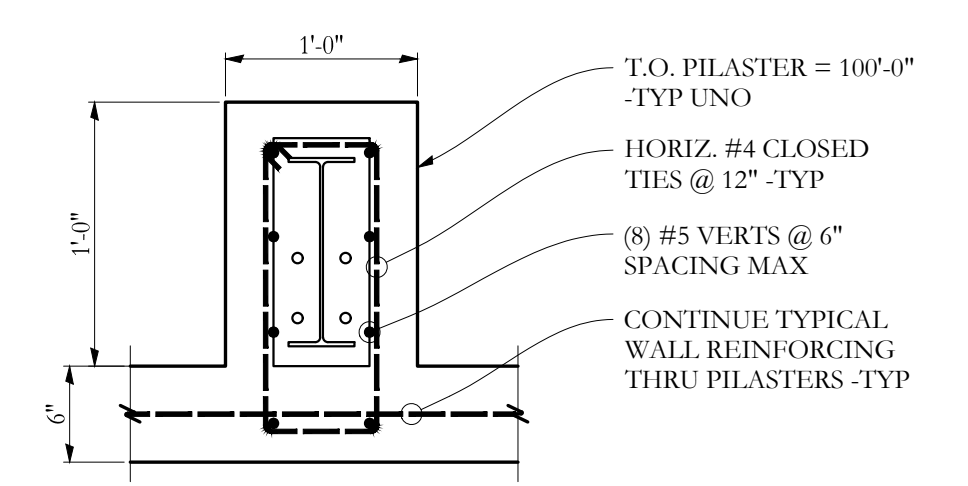

3/4"=1'-0 **M** DETAIL  
 S2.2  
**TYPICAL STRAIGHT PILASTER**

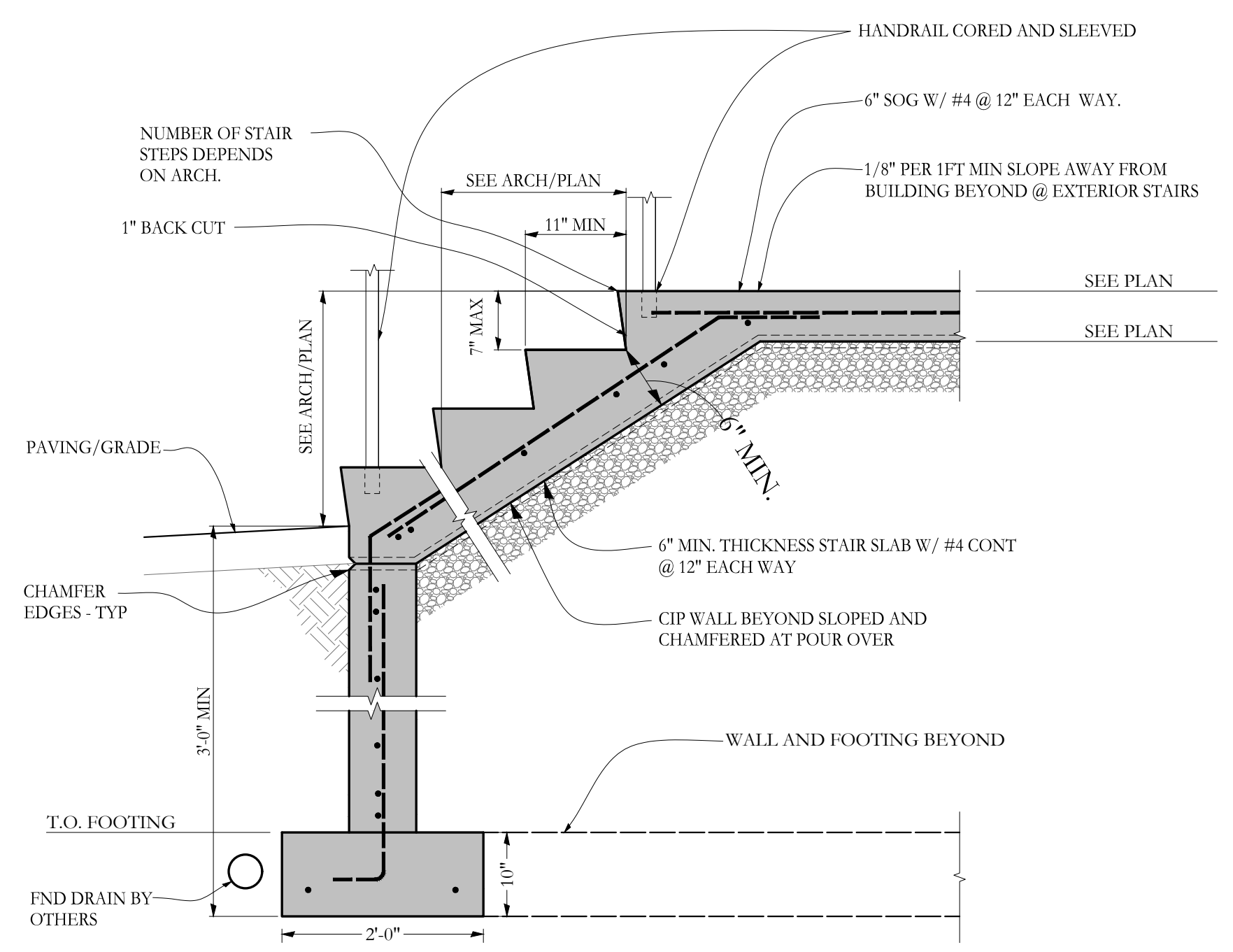

SECTION **H** 1 1/2"=1'-0  
 S2.2

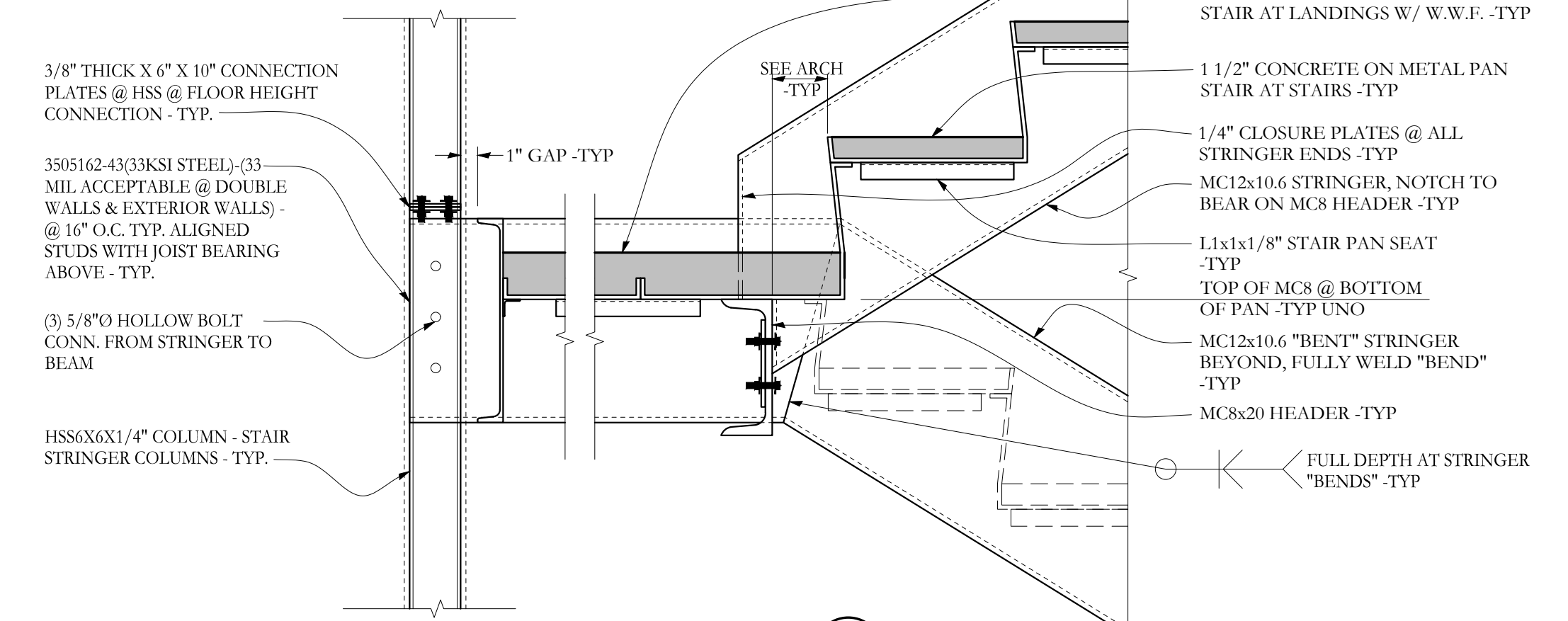

SECTION **J** 1 1/2"=1'-0  
 S2.2

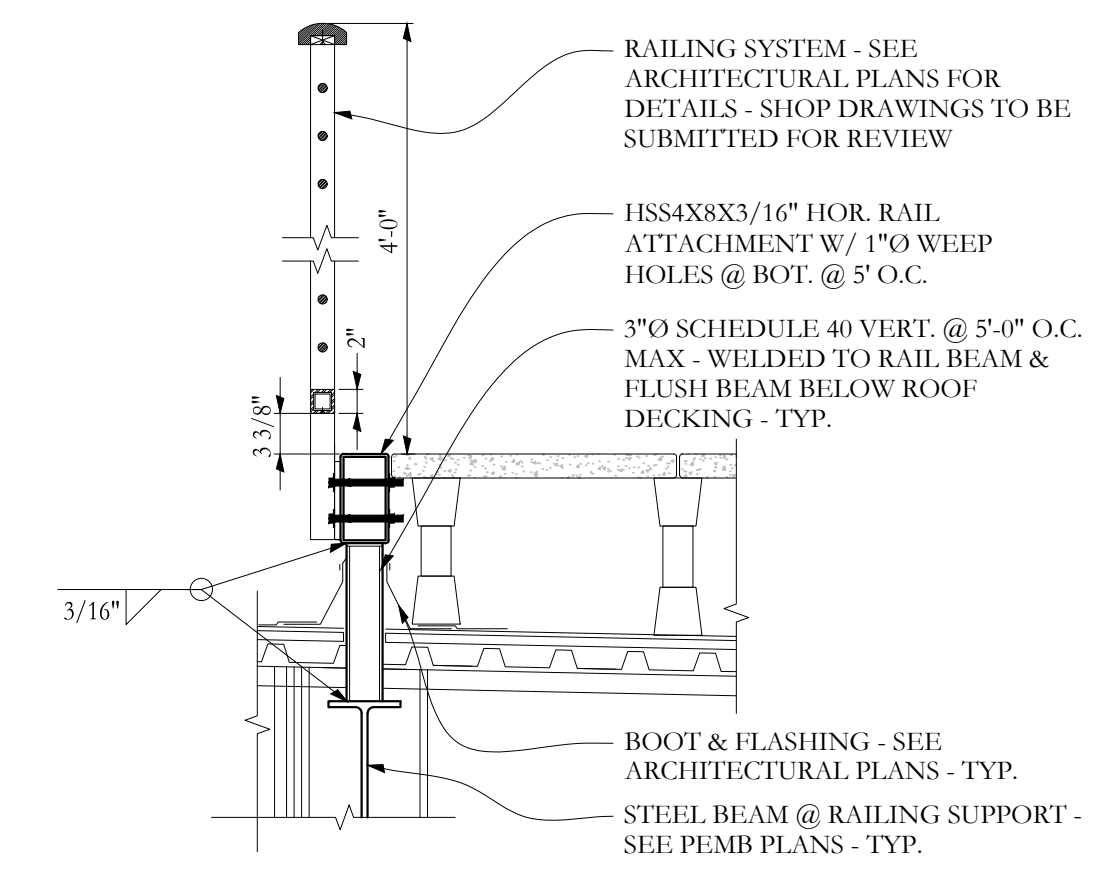

SECTION **K** 1 1/2"=1'-0  
 S2.2