

17 NEW ROLL DOWN FIRE DOOR SECTION DETAIL
1/12" = 1'-0"

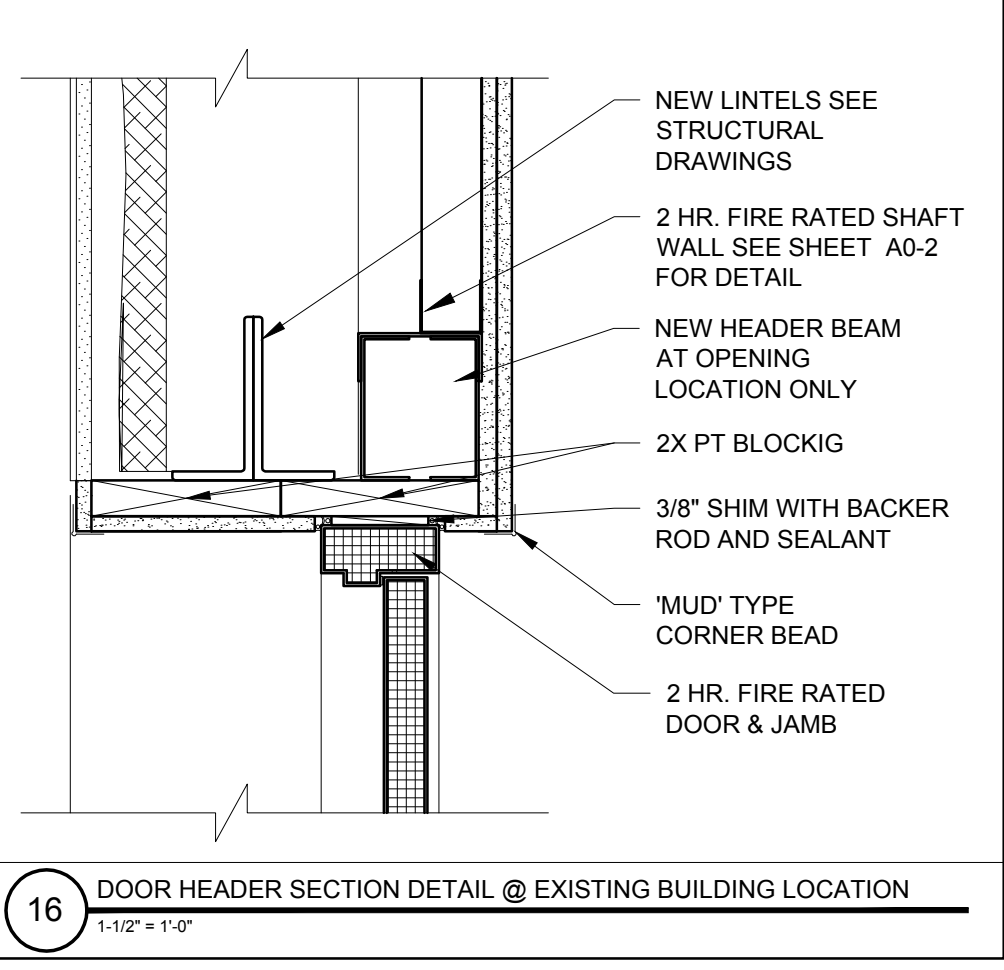

16 DOOR HEADER SECTION DETAIL @ EXISTING BUILDING LOCATION
1/12" = 1'-0"

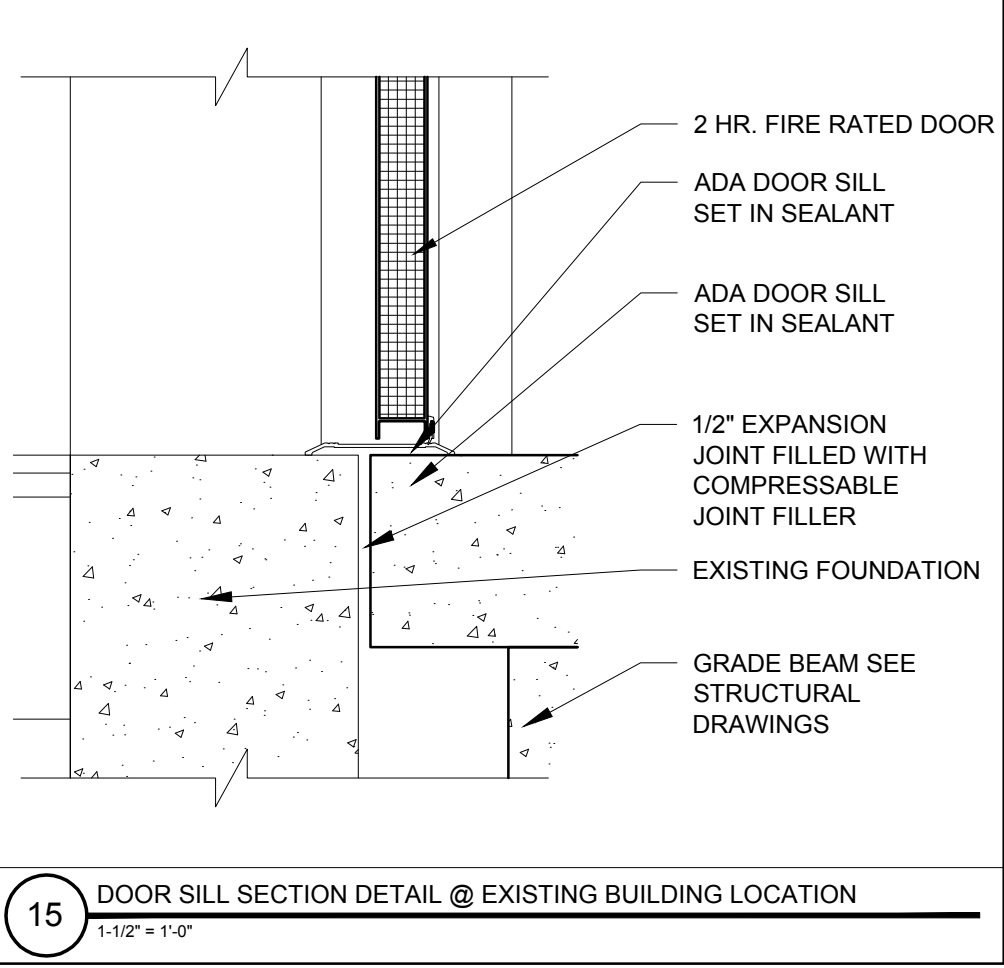

15 DOOR SILL SECTION DETAIL @ EXISTING BUILDING LOCATION
1/12" = 1'-0"

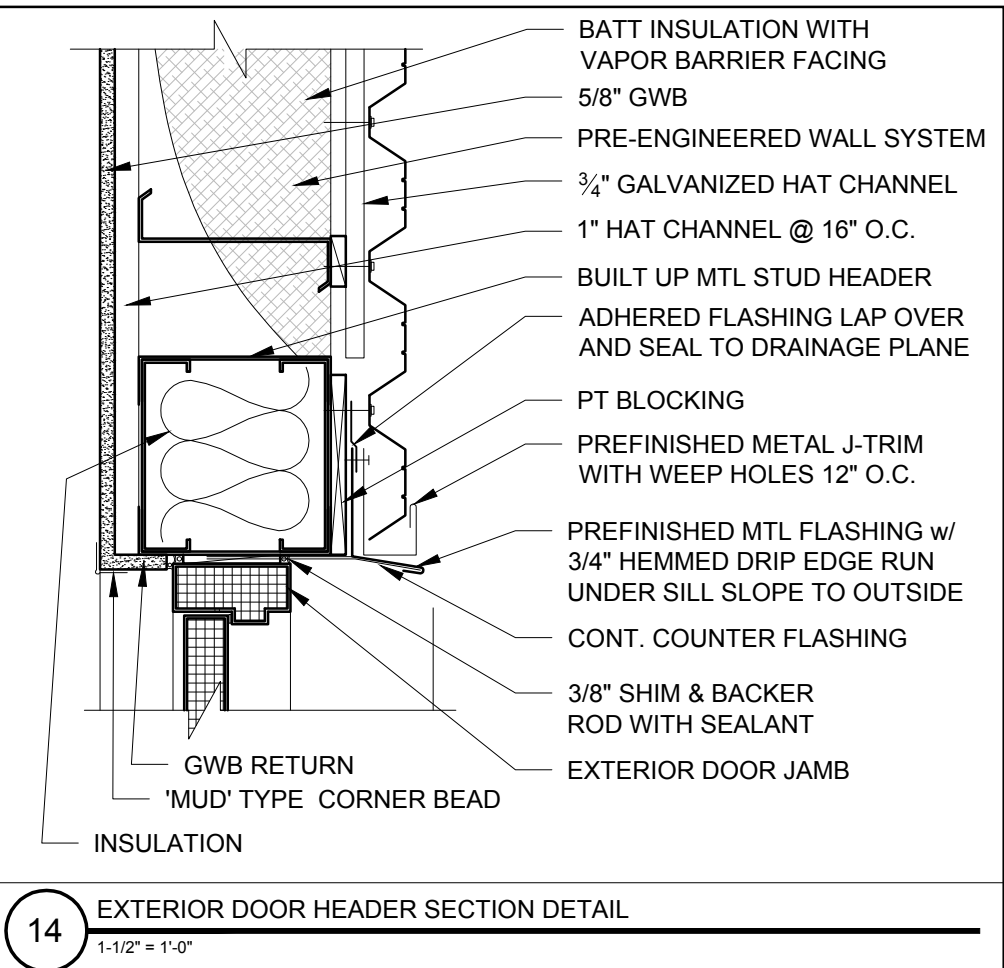

14 EXTERIOR DOOR HEADER SECTION DETAIL
1/12" = 1'-0"

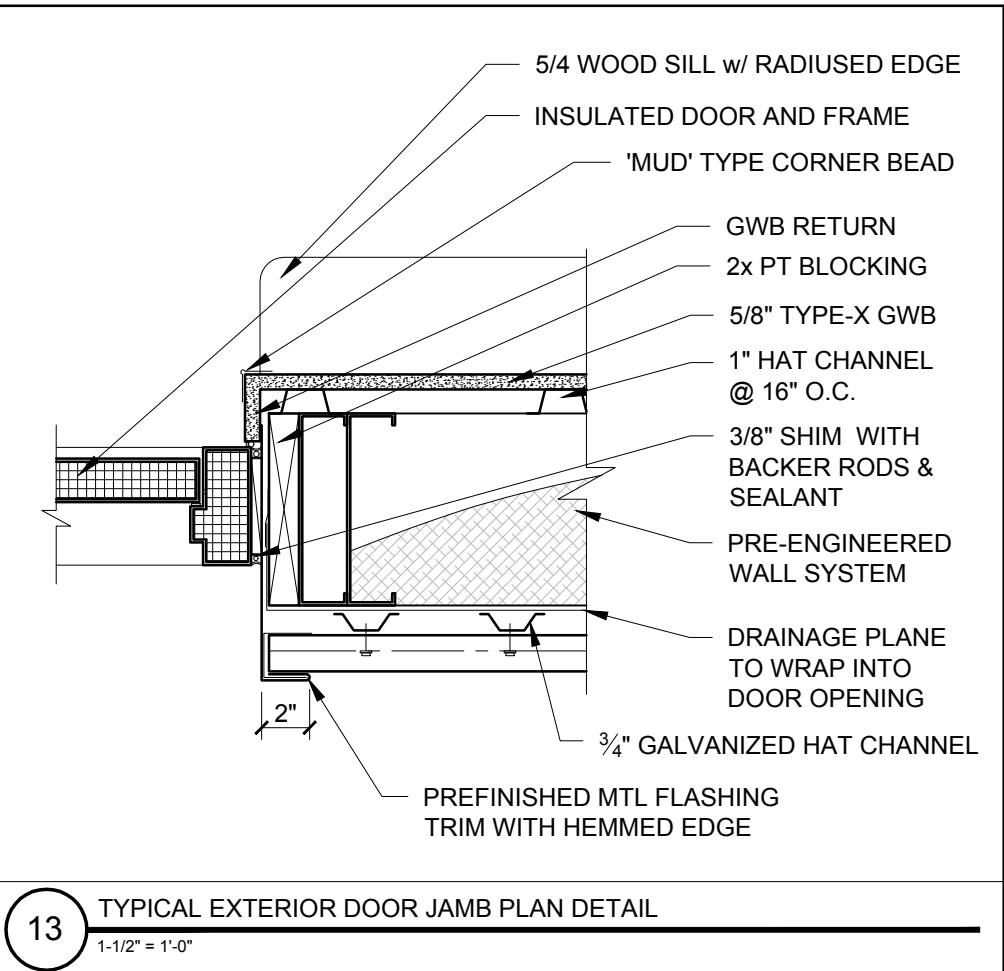

13 TYPICAL EXTERIOR DOOR JAMB PLAN DETAIL
1/12" = 1'-0"

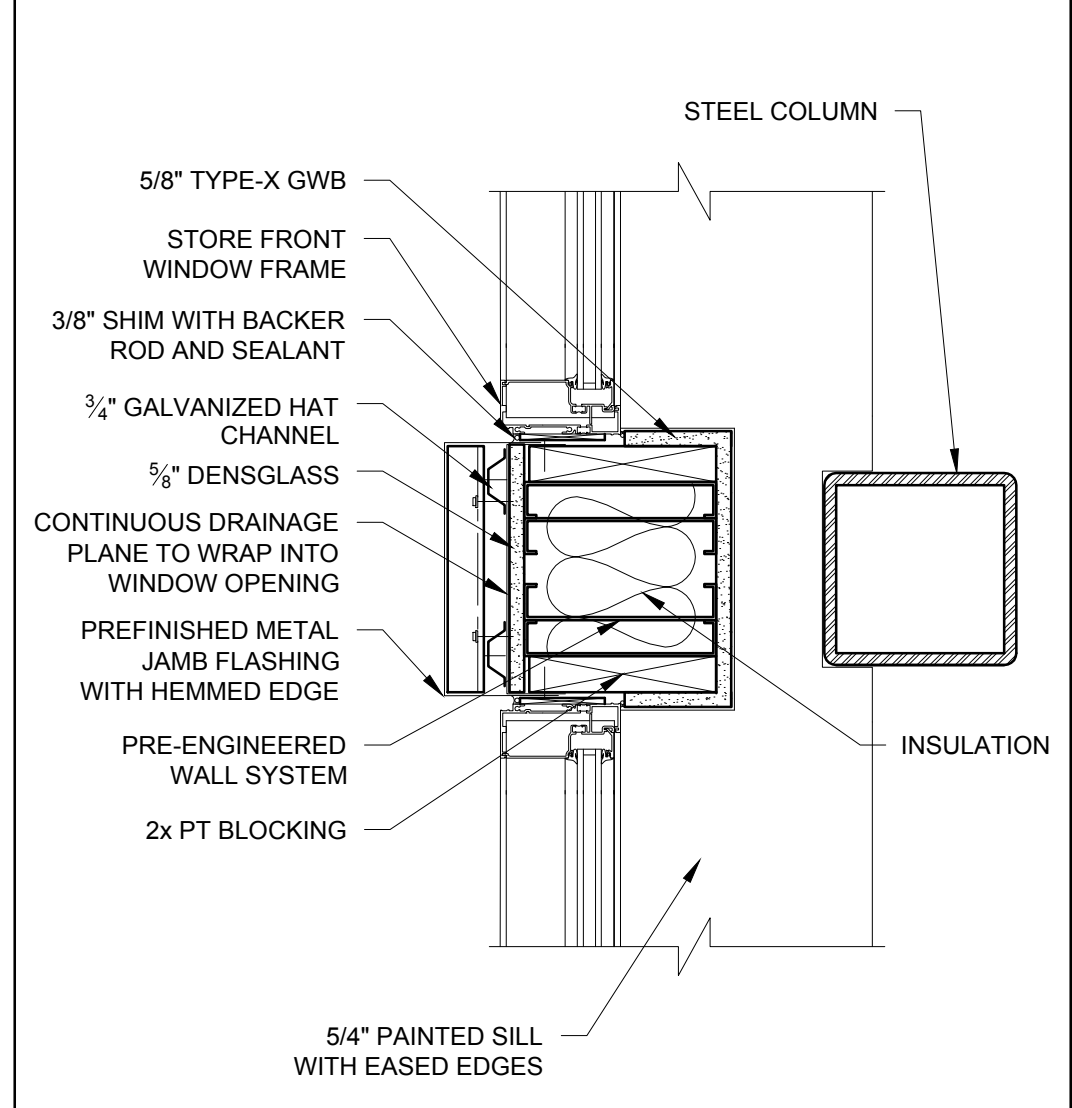

12 DOUBLE WINDOW JAMB PLAN DETAIL @ COLUMN LOCATION
1/12" = 1'-0"

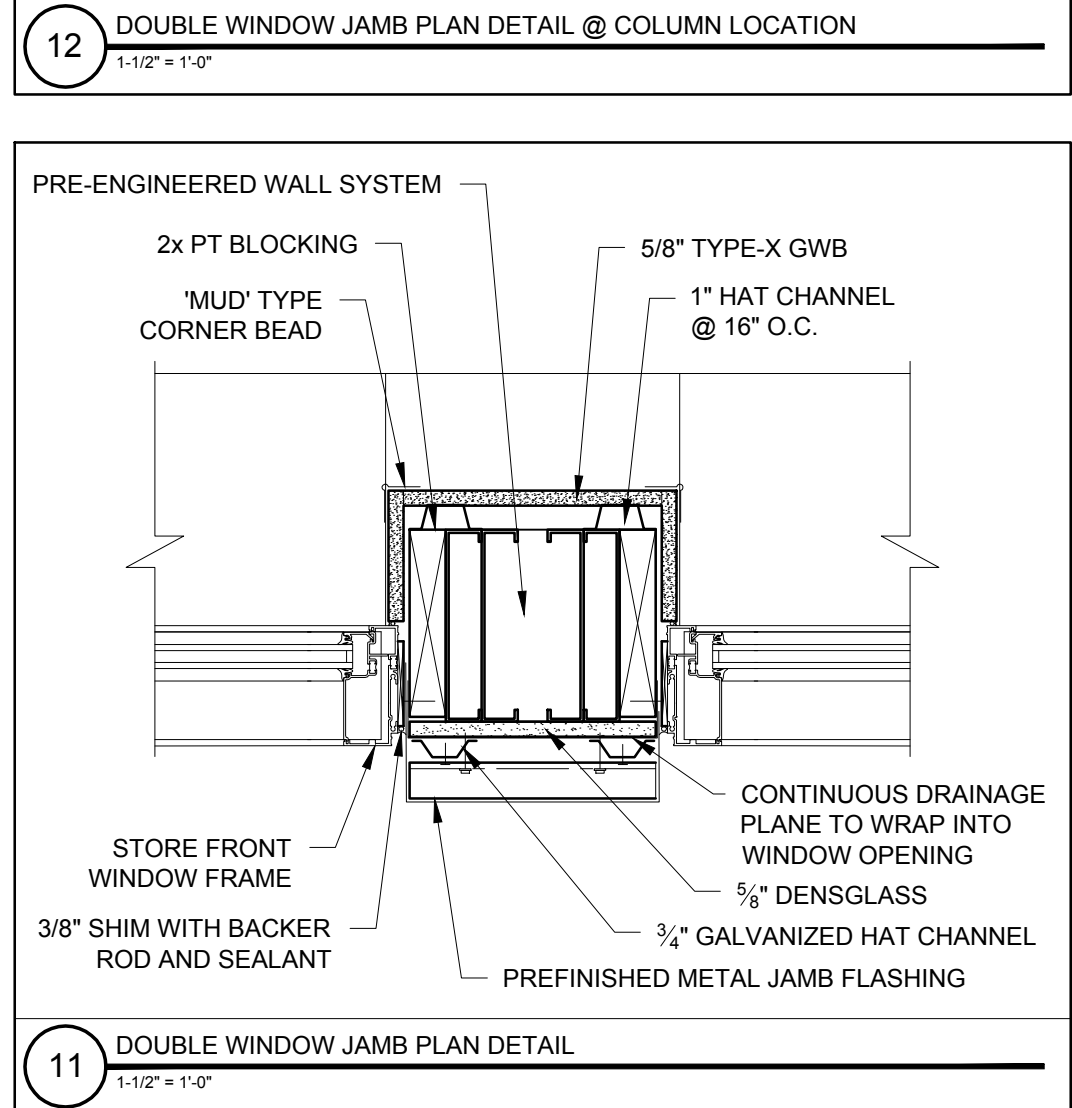

11 DOUBLE WINDOW JAMB PLAN DETAIL
1/12" = 1'-0"

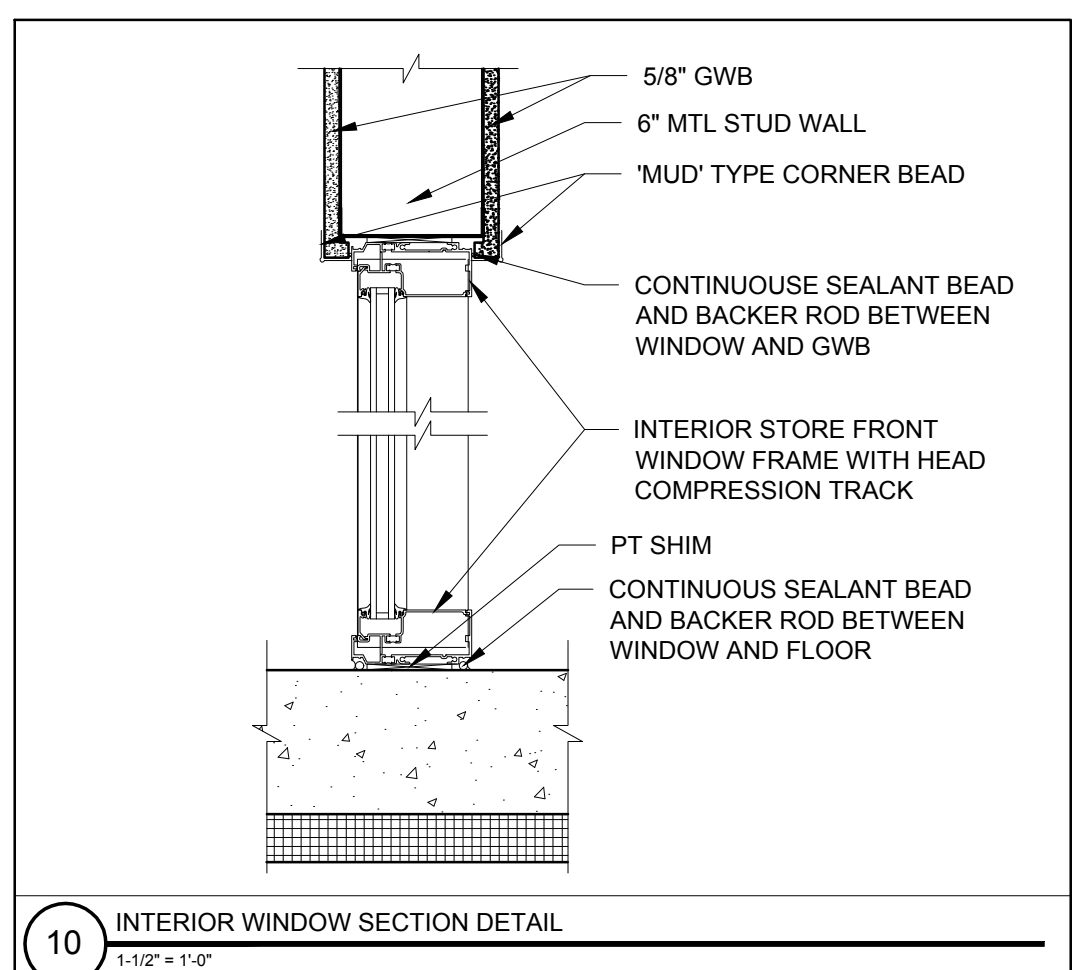

10 INTERIOR WINDOW SECTION DETAIL
1/12" = 1'-0"

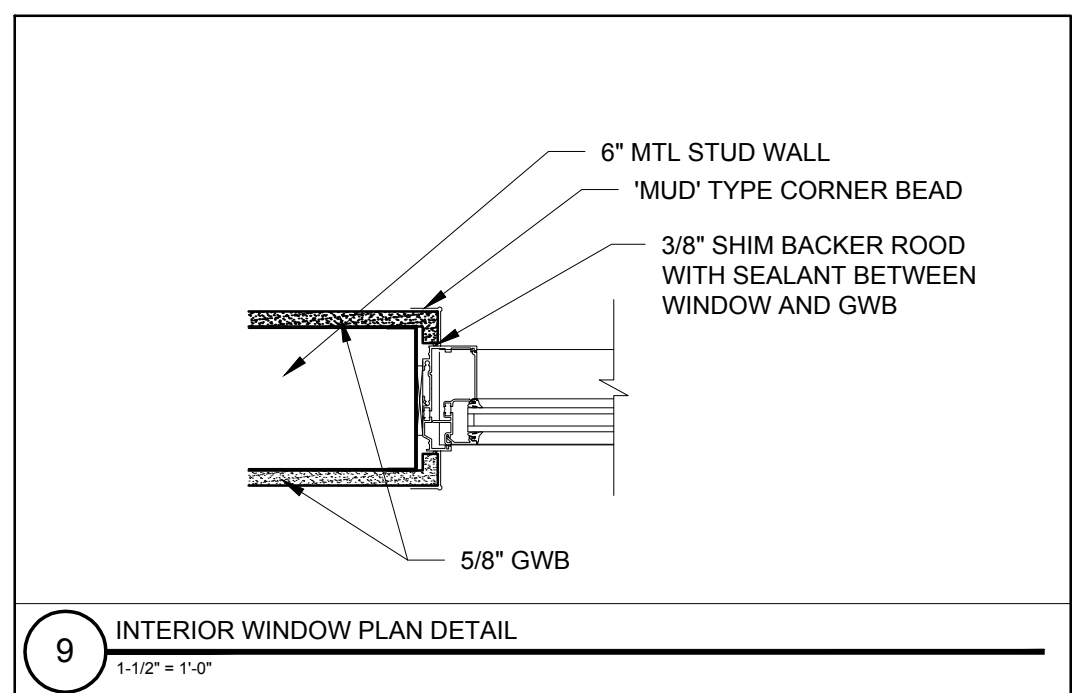

9 INTERIOR WINDOW PLAN DETAIL
1/12" = 1'-0"

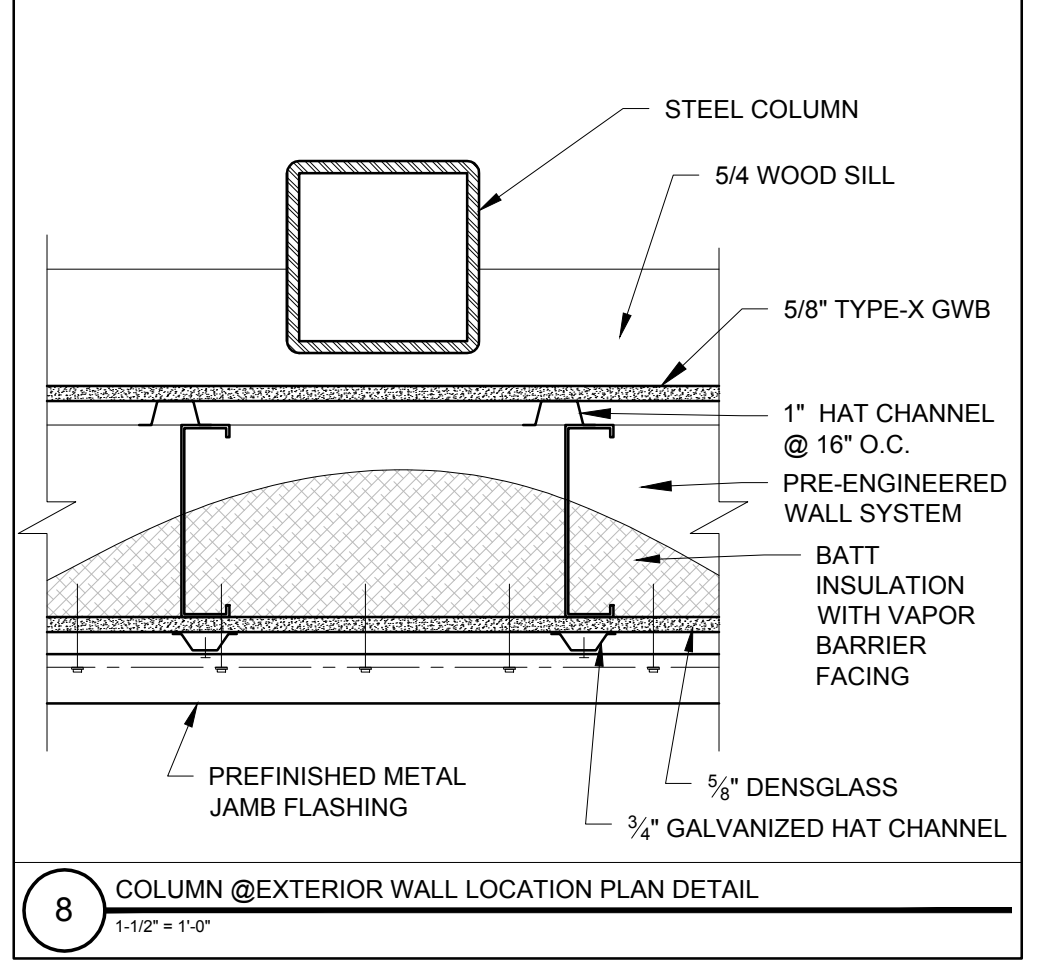

8 COLUMN @ EXTERIOR WALL LOCATION PLAN DETAIL
1/12" = 1'-0"

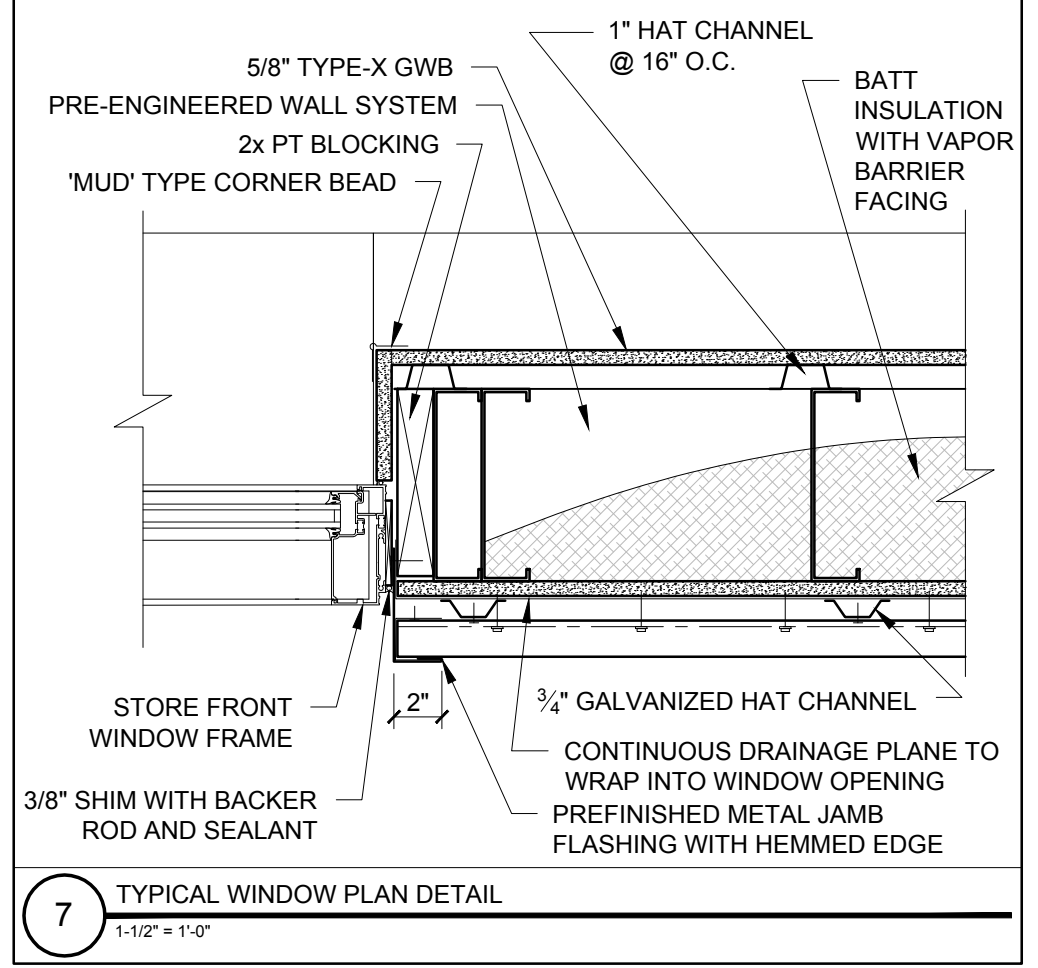

7 TYPICAL WINDOW PLAN DETAIL
1/12" = 1'-0"

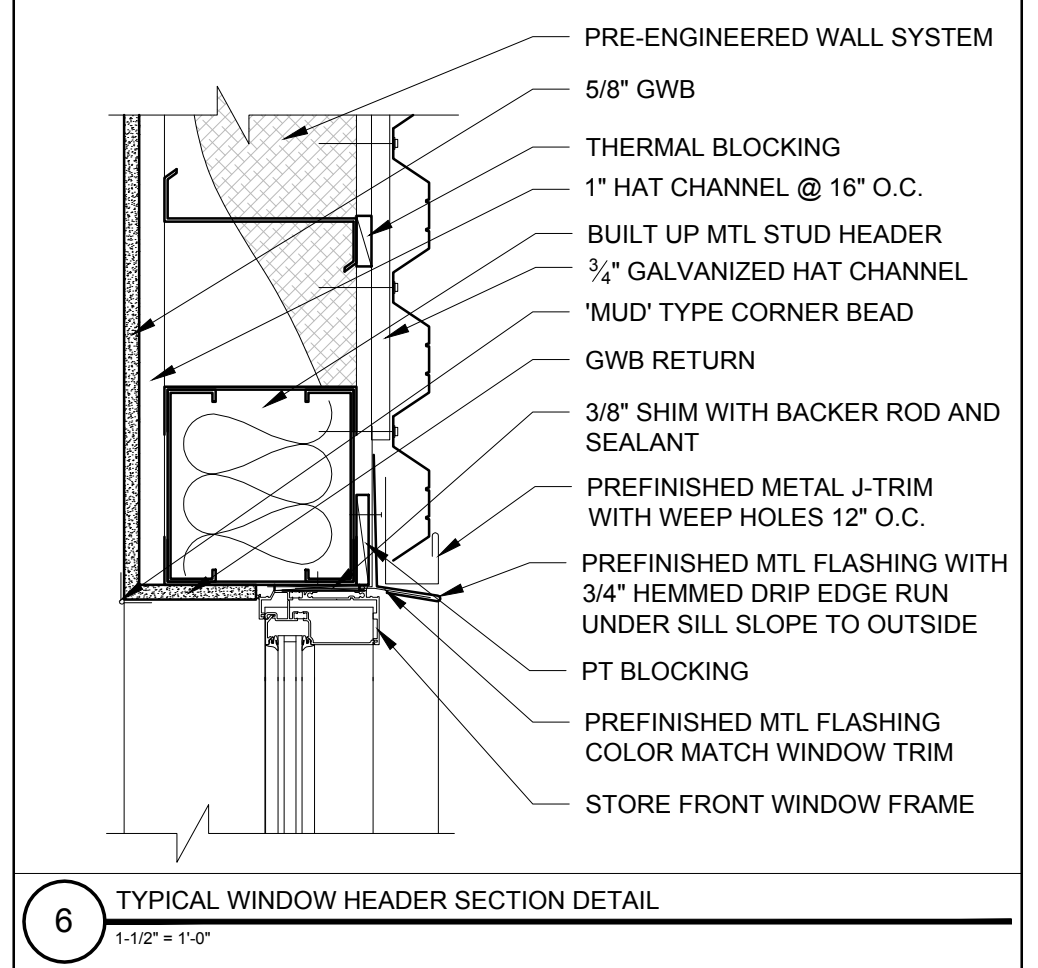

6 TYPICAL WINDOW HEADER SECTION DETAIL
1/12" = 1'-0"

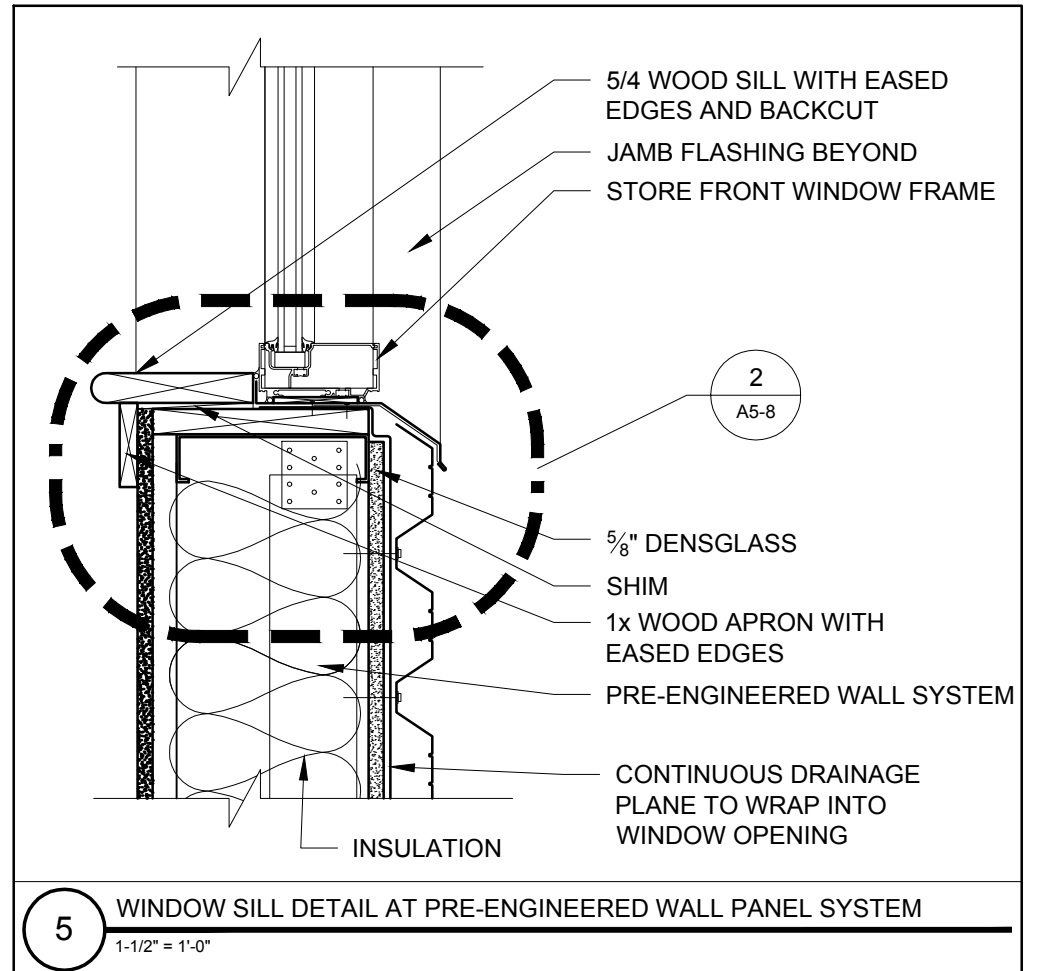

5 WINDOW SILL DETAIL AT PRE-ENGINEERED WALL PANEL SYSTEM
1/12" = 1'-0"

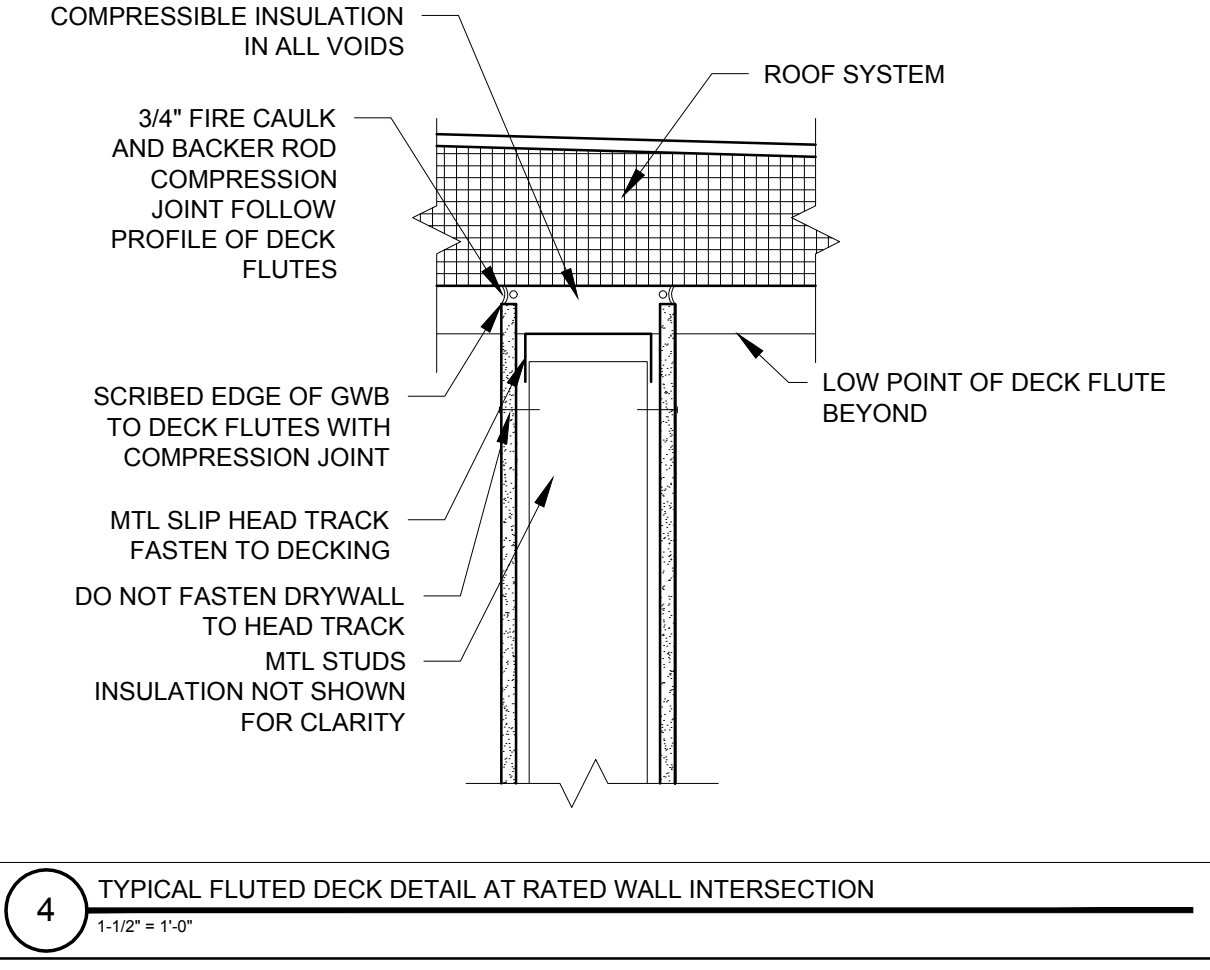

4 TYPICAL FLUTED DECK DETAIL AT RATED WALL INTERSECTION
1/12" = 1'-0"

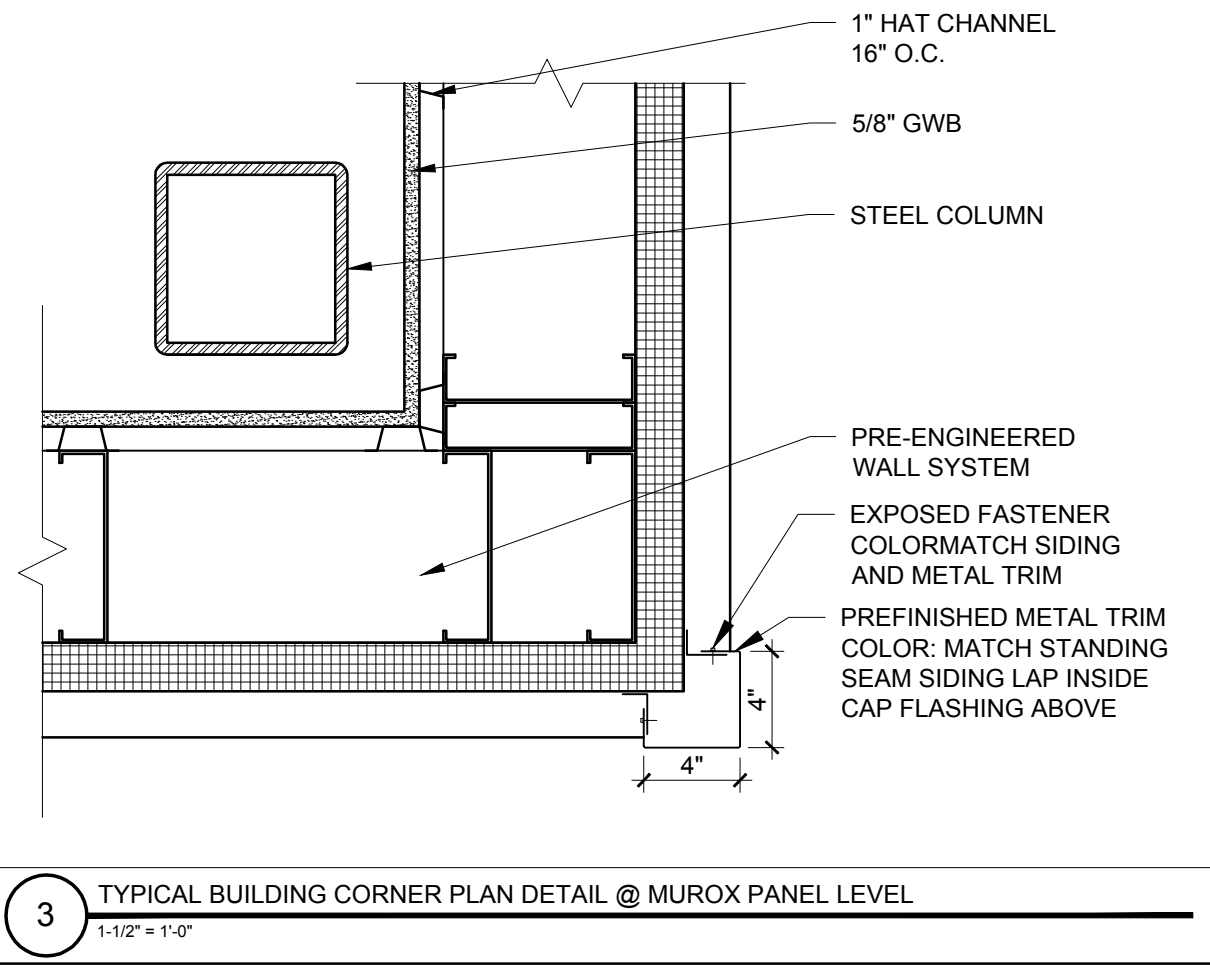

3 TYPICAL BUILDING CORNER PLAN DETAIL @ MUROX PANEL LEVEL
1/12" = 1'-0"

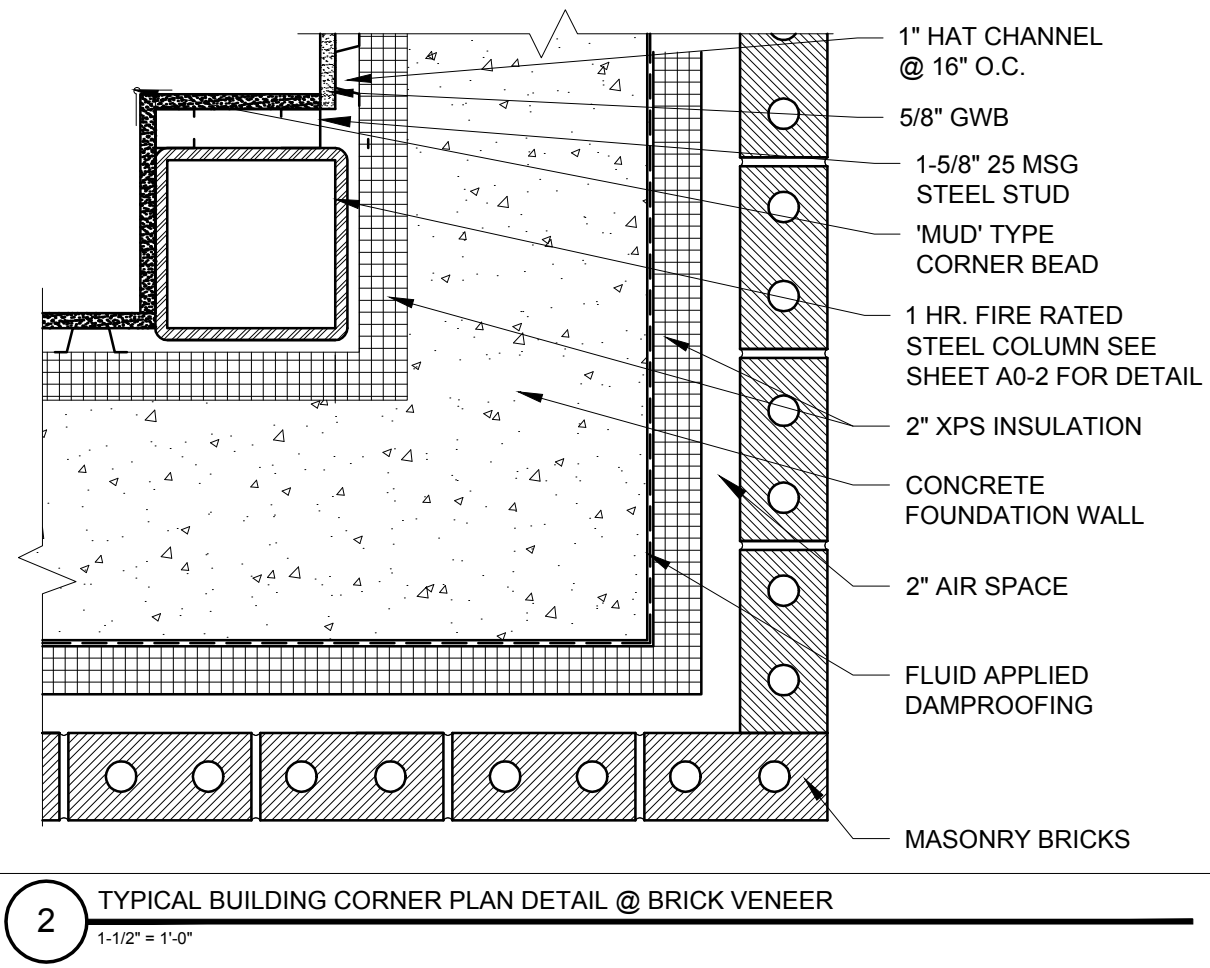

2 TYPICAL BUILDING CORNER PLAN DETAIL @ BRICK VENEER
1/12" = 1'-0"

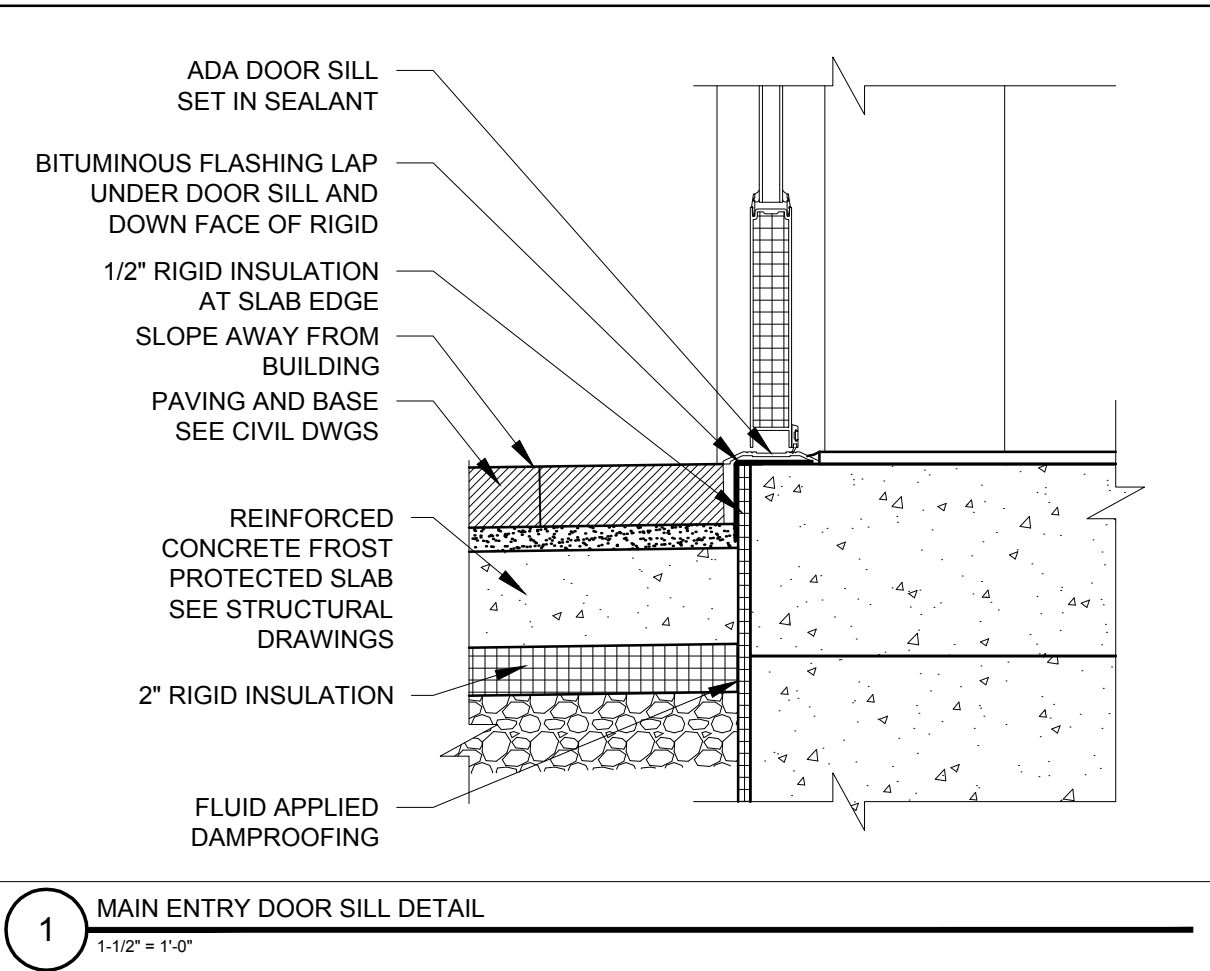

1 MAIN ENTRY DOOR SILL DETAIL
1/12" = 1'-0"

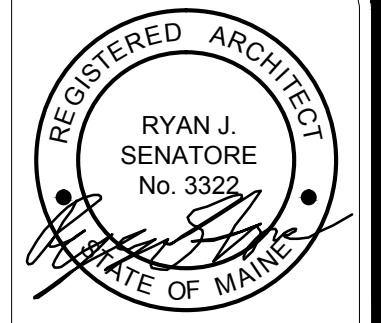

© 2016 RYAN SENATORE ARCHITECTURE

ADDITION TO BAYSIDE BOWL
ALDER STREET
PORTLAND, MAINE



RYAN SENATORE ARCHITECTURE
565 CONGRESS STREET
PORTLAND, MAINE 04101
207-656-6414
senatorearchitecture.com

CONSULTANTS:
STRUCTURAL: Structural Integrity
77 Oak Street
Portland, ME 04101
207-774-4814

REVISIONS:

DATE: JANUARY 29, 2016
PROJECT No. 1452
DRAWN BY: JPF / RRT / RJS
CHECKED BY: RJS
SCALE: AS NOTED

SHEET TITLE:
DETAILS

A5-3