

A STOREFRONT SECTION
SCALE: 1/2" = 1'-0"

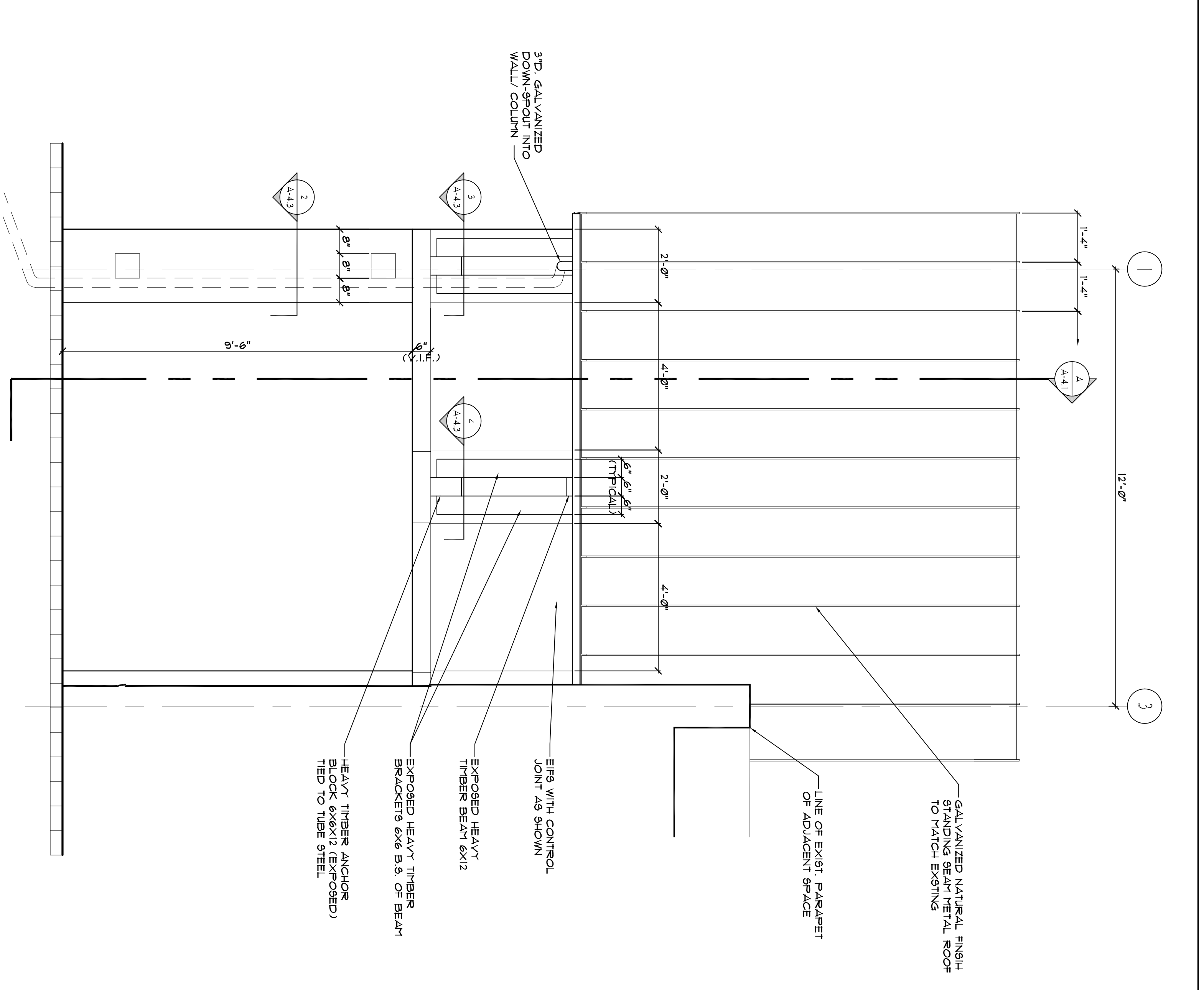

B DETAILED ELEVATION @ COVERED ENTRY
SCALE: 1/2" = 1'-0"

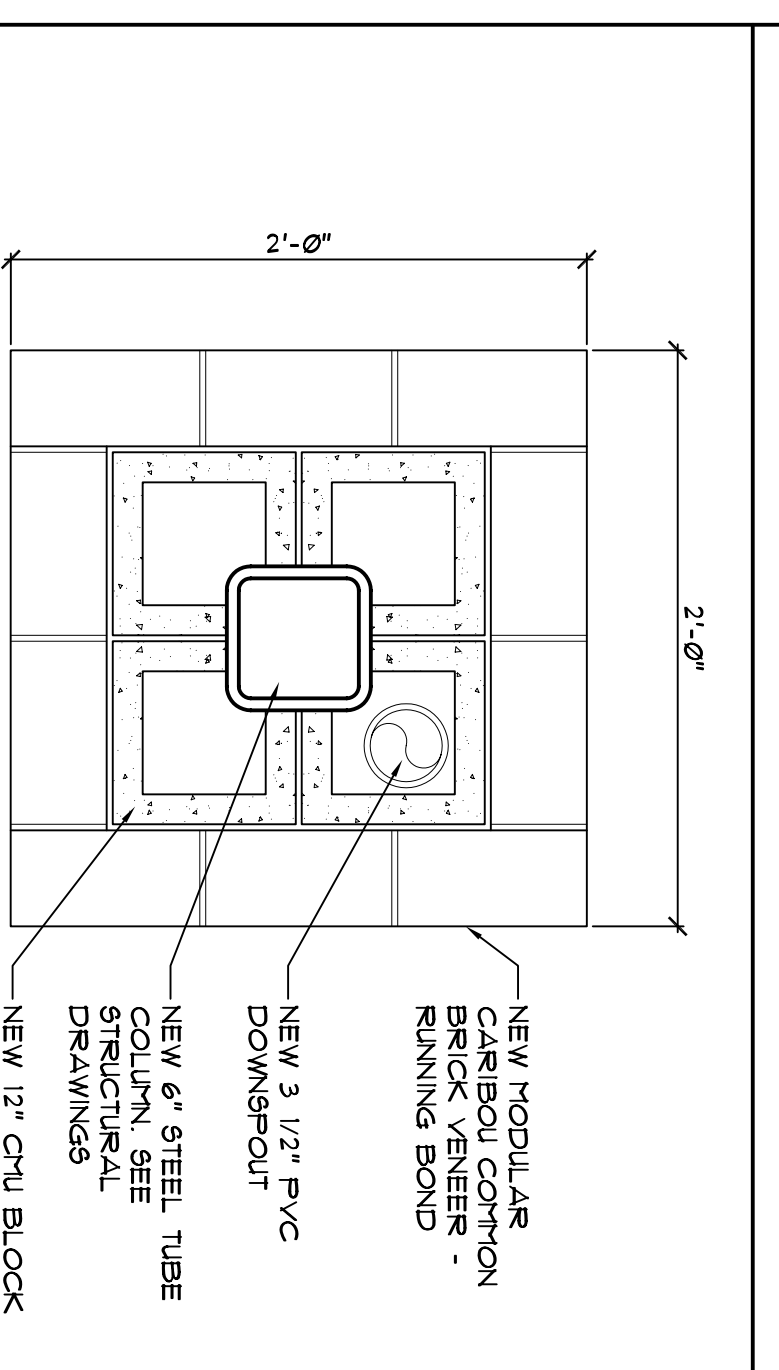

1 COLUMN DETAIL
SCALE: 1/2" = 1'-0"

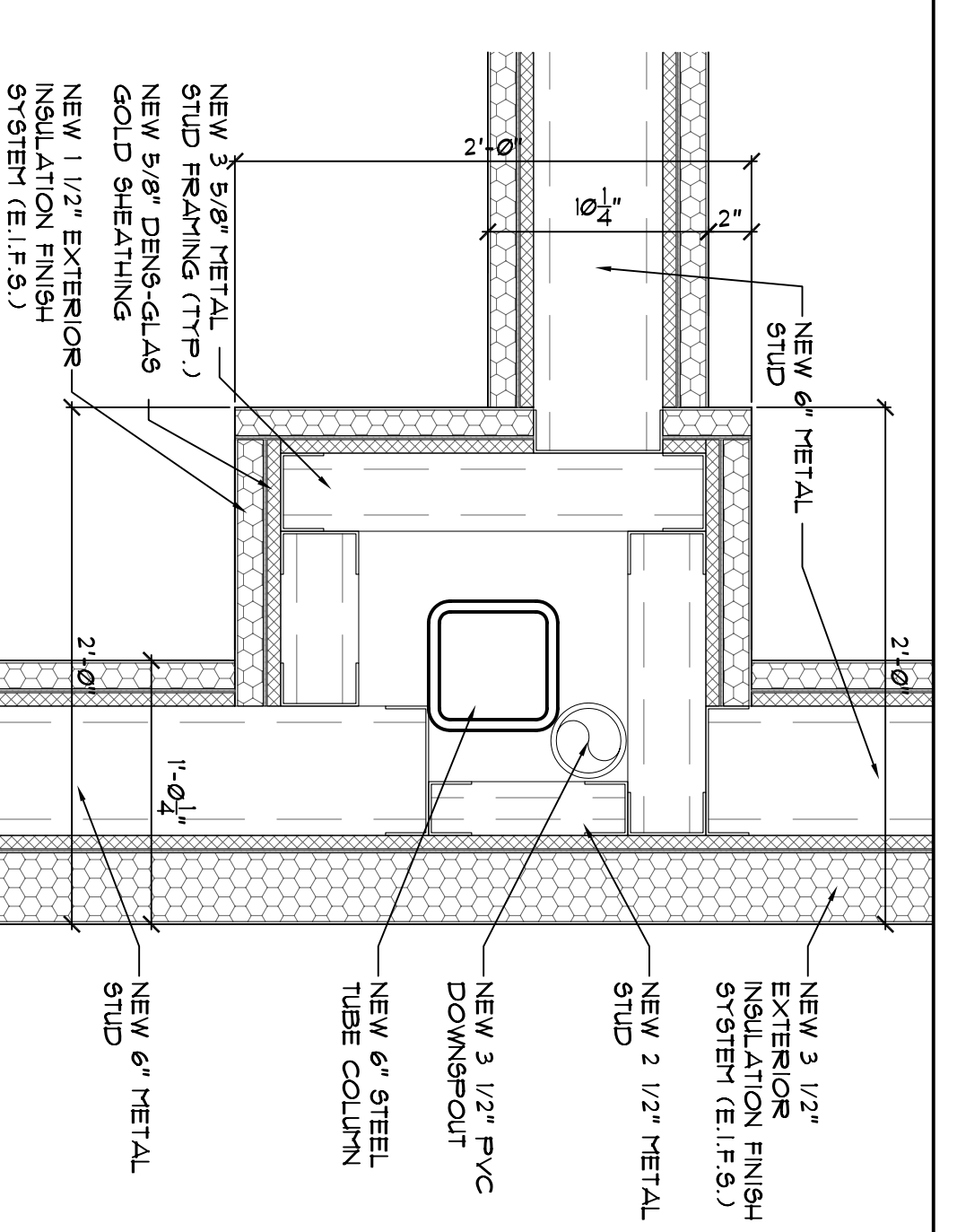

3 COLUMN DETAIL @ INTERMEDIATE COLUMN
SCALE: 1/2" = 1'-0"

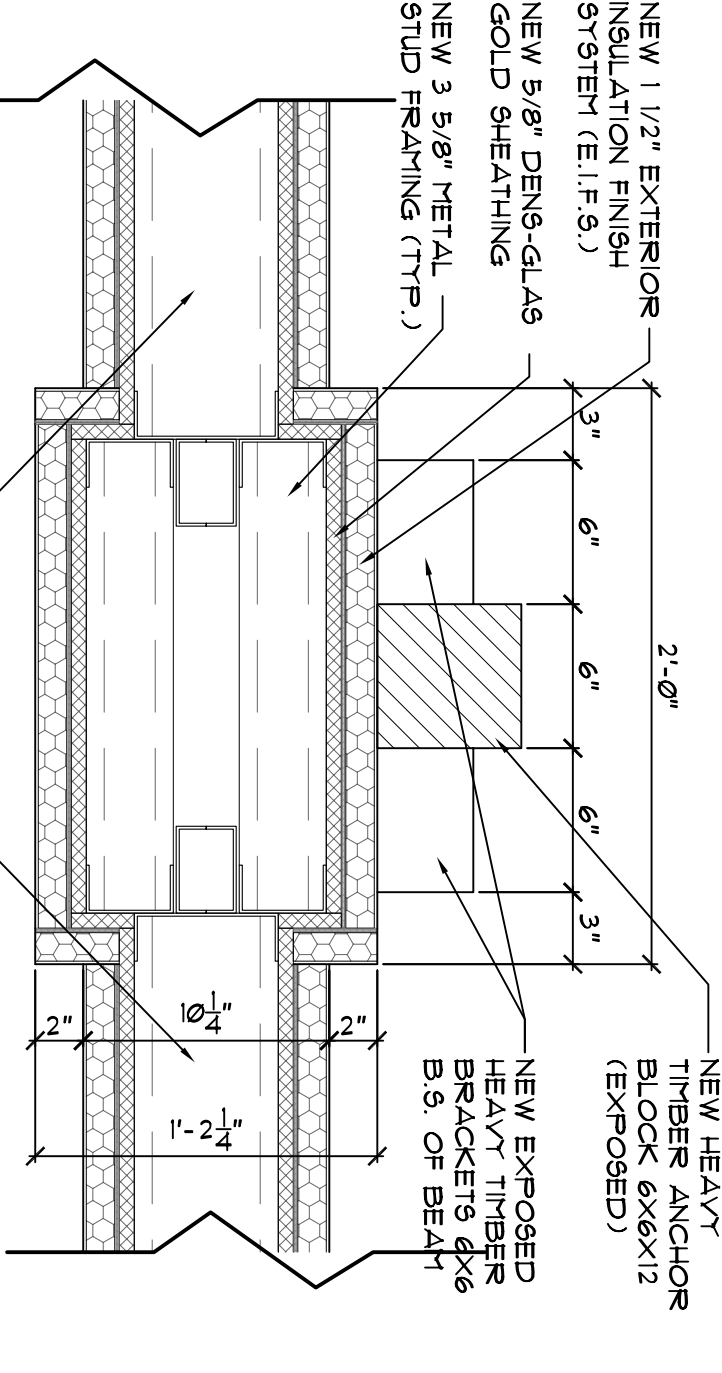

4 WALL DETAIL
SCALE: 1/2" = 1'-0"

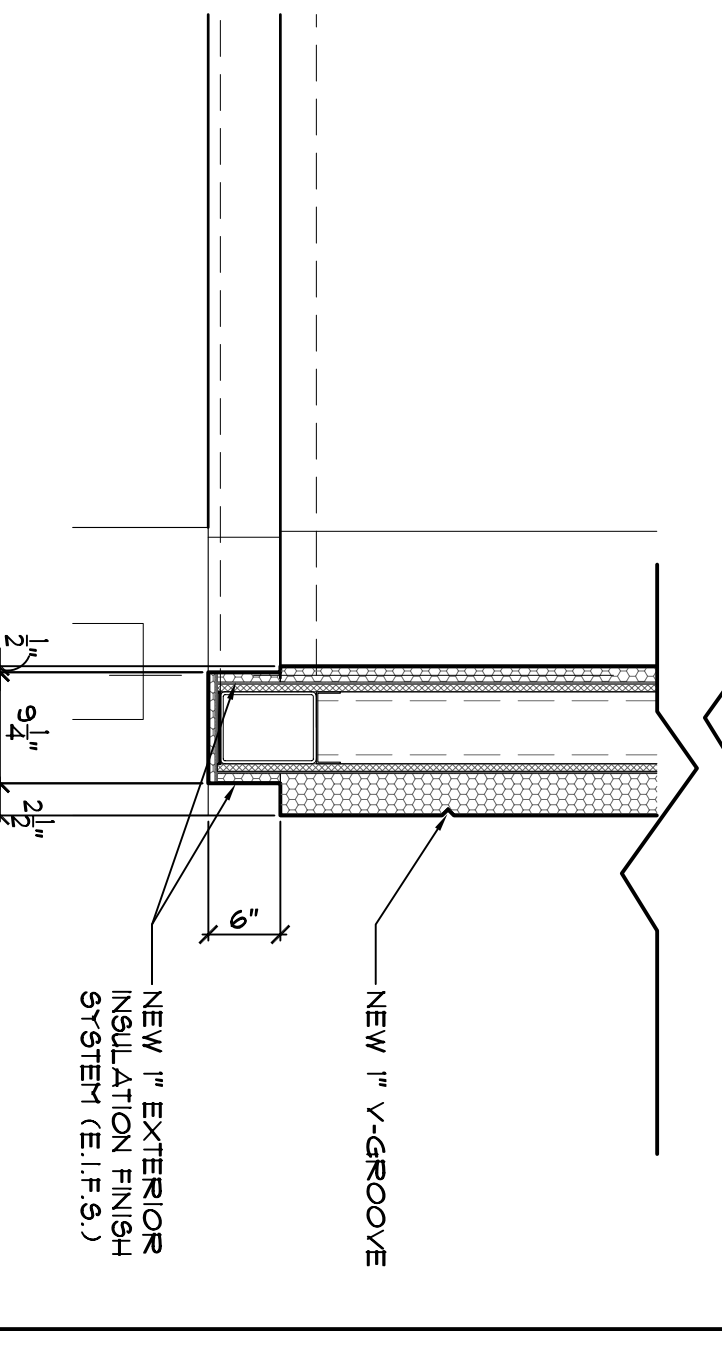

5 WALL DETAIL
SCALE: 3/4" = 1'-0"

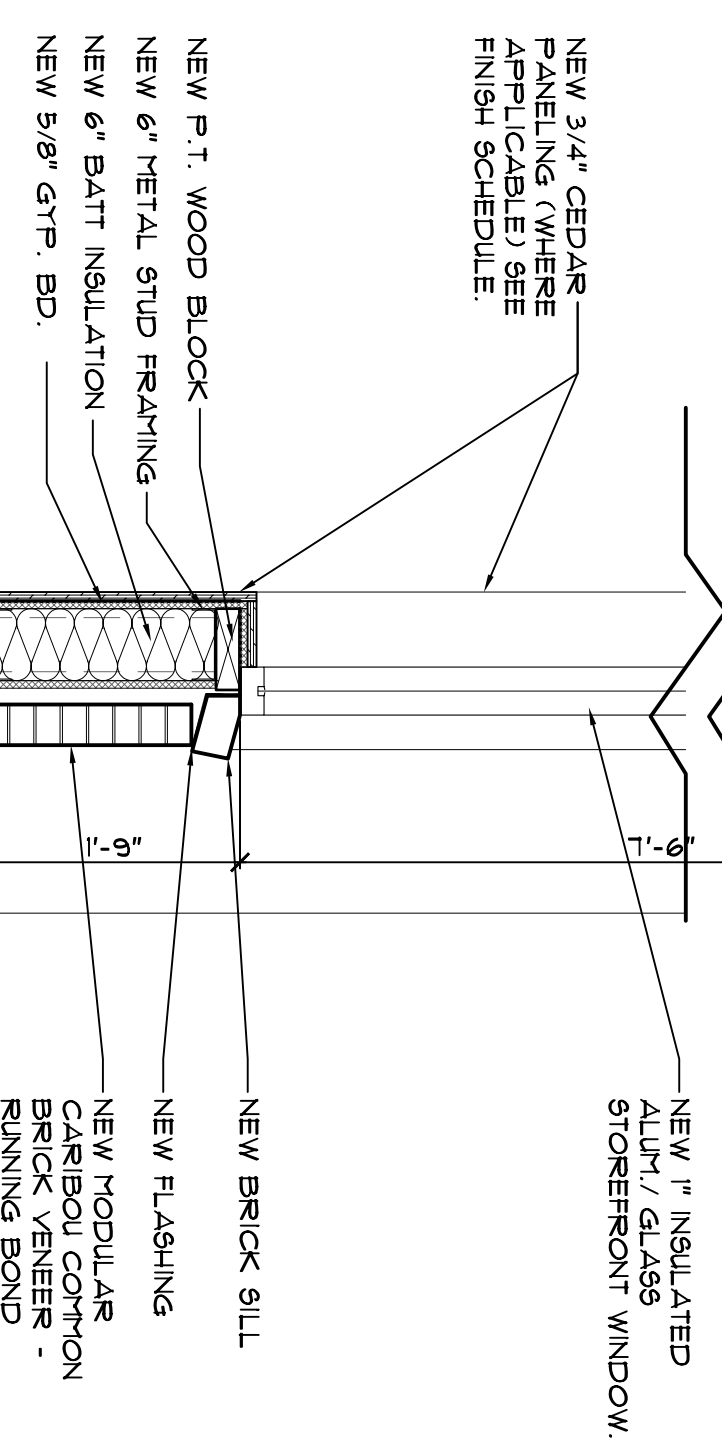

6 WALL DETAIL
SCALE: 3/4" = 1'-0"

Jeffrey Taylor
Architect
572 North Broadway
White Plains, N.Y. 10603
Tel. 914 289 0011
Fax 914 289 0022

NO.	DATE	COMMENTS

SALES: 17,224 sq. ft.	DATE: 04/28/10	REVISIONS:
STOCK: 5,424 sq. ft.	JOB No. FT-1912	NO. DATE
MISC: 1,464 sq. ft.	DRAWN BY: FTA	
TOTAL: 23,930 sq. ft.	TENANT STORE No. XXX	
	SPACE No. XXXX	

TRADER JOE'S
81 MARGINAL WAY
PORTLAND, ME. 04101

A-4-3

SHEET NAME: **DETAILS AND SECTIONS**