



PO Box 2551  
2257 West Broadway  
South Portland, ME 04106

1.800.370.3473  
fax 207.879.0540

[www.norrisinc.com](http://www.norrisinc.com)

# ***SUBMITTAL PACKAGE***

**Project: Schlotterbeck Block**

**System: Fire Alarm System**

**Submitted By: Norris Inc.  
2257 West Broadway  
South Portland, Maine 04106  
Telephone: (800) 370-3473**

**Date: July 11th, 2016**

## **Norris Inc**

2257 West Broadway

South Portland, ME 04106

1-800-370-3473

### **COREY ELECTRIC, INC.**

609 MAIN STREET, STE 3

WESTBROOK, ME 04092

**323632SP**

## **Equipment List**

Tel:207-591-8151 Fax:207-591-8153

### **Schlotterbeck Block Fire Alarm**

#### **Description**

NOTIFIER-NFS-320, Addressable Fire Alarm Control Panel

NOTIFIER-UDACT-2, Universal Digital Alarm Communicator Transmitter-2

R5-RJ31X, UL 8P8C RJ31X JACK

R5-804R8, SILVER SATIN 8' PLUG - PLUG

IM-12180, 12V 18AH Battery

NOTIFIER-NBG-12LX, Addressable Pull Station

NOTIFIER-FSP-851, Intelligent Address Photo detector w/ FlashScan.

NOTIFIER-FST-851, Intelligent Address 135 degree thermal detector w/FlashScan.

NOTIFIER-B210LP, Conventional Flanged mnt. Base

NOTIFIER-FCO-851, Smoke/Co Combo

NOTIFIER-B200S, Intelligent, Address, programmable plug-in sounder base

NOTIFIER-CO1224TR, Convent/Carbon Monoxide Detector,12/24 VDC,w/sounder

NOTIFIER-FMM-101, Address Mini Mod.

NOTIFIER-DNR, InnovairFlex intelligent duct detector, non-relay, no head.

NOTIFIER-FSP-851R, Remote test capable Intelligent Photo detector w/FlashScan

NOTIFIER-DST3, InnovairFlex sampling tube, steel, 3# w/ holes

NOTIFIER-RTS151, Remote test Stat.; w/ switch, alarm and power LED#s.

NOTIFIER-FRM-1, Address Relay Mod.

NOTIFIER-FMM-101, Address Mini Mod (sprinkler)

NOTIFIER-FCPS-24S8, 8.0 amps, 120 VAC remote charger PS.

IM-1270, 12V 7AH Battery

NOTIFIER-P2R, Horn Strobe, Wall, Red

NOTIFIER-SR, Strobe, Wall, Red

Space Age-SSU00690, Fire Alarm Records Cabinet

Knox Box, Recessed, Lift Cover, Black

## **Norris Inc**

2257 West Broadway

South Portland, ME 04106

1-800-370-3473

## **COREY ELECTRIC, INC.**

609 MAIN STREET, STE 3

WESTBROOK, ME 04092

**323632SP**

## **Equipment List**

Tel:207-591-8151 Fax:207-591-8153

### **Schlotterbeck Block Master Box and 120v Smoke Detection**

#### **Description**

SPECIAL-KNOXR-BLACK, Black Knox Box Color

SPECIAL-AES, AES Radio Masterbox

AES-7788F, UL Fire 8 Zone

EK-TRG1640, 16.5VAC, 45VA Transformer

IM-1270, 12V 7AH Battery

AES-7210-5-UM, 5dB Omni directional UHF Antenna

AES-13-0346, Cable Assembly; 18# RG-58

AES-7230, Standard Coaxial Surge Protector, N female N female

SR-3025TM, Tamper Switch

SPAAGEELE-VS000091, AES Radio Disconnect Enclosure

GENTEX-GN-503F, 120VAC/9VDC Sng/Mult.SmK/COAlarm Un/mntTemporal Sng.,

GENTEX-7139CS-C, 120VAC/9VDC Sng/Mult. Alarm, 177 Cd, Temporal Sng.

GENTEX-GXS120-177WW, 120VAC Strobe 177cd Wall, White

# NFS-320

## Intelligent Addressable Fire Alarm System



### Intelligent Fire Alarm Control Panels

#### General

The NFS-320 intelligent Fire Alarm Control Panel is part of the ONYX® Series of Fire Alarm Controls from NOTIFIER.

In stand-alone or network configurations, ONYX Series products meet virtually every application requirement.

The NFS-320's modular design makes system planning easier. The panel can be configured with just a few devices for small building applications, or networked with many devices to protect a large campus or a high-rise office block. Simply add additional peripheral equipment to suit the application.

For installations using NFS-320C, an optional ACM Series annunciator can be mounted in the same cabinet (up to 48 zones/points, order separately; see DN-60085).

**NOTE:** Unless called out with a version-specific "R", "C" or "E" at the end of the part number, "NFS-320" refers to models NFS-320, NFS-320R, NFS-320C, and NFS-320E.



NFS-320

#### Features

- Certified for seismic applications when used with the appropriate seismic mounting kit.
  - Approved for Marine applications when used with listed compatible equipment. See DN-60688.
  - One isolated intelligent Signaling Line Circuit (SLC) Style 4, 6 or 7.
  - Up to 159 detectors (any mix of ion, photo, thermal, or multi-sensor) and 159 modules (Addressable pull stations, normally open contact devices, two-wire smoke detectors, notification, or relay). 318 devices maximum.
  - Standard 80-character display.
  - Network options:
    - High-speed network for up to 200 nodes (NFS2-3030, NFS2-640, NFS-320(C), NFS-320SYS, NCA-2, DVC-EM, ONYXWorks, NFS-3030, NFS-640, and NCA).
    - Standard network for up to 103 nodes (NFS2-3030, NFS2-640, NFS-320(C), NFS-320SYS, NCA-2, DVC-EM, ONYXWorks, NCS, NFS-3030, NFS-640, NCA, AFP-200, AFP-300/400, AFP-1010, and AM2020). Up to 54 nodes when DVC-EM is used in network paging.
  - 6.0 A power supply with four Class A/B built-in Notification Appliance Circuits (NAC). Selectable System Sensor, Wheelock, or Gentex strobe synchronization.
  - Built-in Alarm, Trouble, Security, and Supervisory relays.
  - VeriFire® Tools online or offline programming utility. Upload/Download, save, store, check, compare, and simulate panel databases. Upgrade panel firmware.
  - Autoprogramming and Walk Test reports.
  - Multiple central station communication options:
    - Standard UDACT
    - Internet
    - Internet/GSM
  - 80-character remote annunciators (up to 32).
  - EIA-485 annunciators, including custom graphics.
  - Printer interface (80-column and 40-column printers).
- History file with 800-event capacity in nonvolatile memory, plus separate 200-event alarm-only file.
  - Alarm Verification selection per point, with automatic counter.
  - Presignal/Positive Alarm Sequence (PAS).
  - Silence inhibit and Auto Silence timer options.
  - NAC coding functions:
    - March time.
    - Temporal.
    - California two-stage coding.
    - Canadian two-stage.
    - Strobe synchronization.
  - Field-programmable on panel or on PC, with VeriFire® Tools program check, compare, simulate.
  - Full QWERTY keypad.
  - Battery charger supports 18 – 200 AH batteries.
  - Non-alarm points for lower priority functions.
  - Remote ACK/Signal Silence/System Reset/Drill via monitor modules.
  - Automatic time control functions, with holiday exceptions.
  - Extensive, built-in transient protection.
  - Powerful Boolean logic equations.

#### FLASHSCAN® INTELLIGENT FEATURES

- Polls up to 318 devices in less than two seconds.
- Activates up to 159 outputs in less than five seconds.
- Multicolor LEDs blink device address during Walk Test.
- Fully digital, high-precision protocol (U.S. Patent 5,539,389).
- Manual sensitivity adjustment — up to nine levels.
- Pre-alarm ONYX intelligent sensing — up to nine levels.
- Day/Night automatic sensitivity adjustment.
- Sensitivity windows:
  - Ion — 0.5 to 2.5%/foot obscuration.

- **Photo** - 0.5 to 2.35%/foot obscuration.
- **Laser (VIEW®)** - 0.02 to 2.0%/foot obscuration.
- **Acclimate® Plus™** - 0.5 to 4.0%/foot obscuration.
- **IntelliQuad** - 1.0 to 4.0%/foot obscuration.
- **IntelliQuad™ PLUS** - 1.0 to 4.0%/foot obscuration
- Drift compensation (U.S. Patent 5,764,142).
- Degraded mode — in the unlikely event that the NFS-320's primary microprocessor fails, FlashScan detectors revert to degraded operation and can activate the control panel's NAC circuits and alarm relay. Each of the four built-in panel circuits includes a Disable/Enable switch for this feature.
- Multi-detector algorithm involves nearby detectors in alarm decision (U.S. Patent 5,627,515).
- Automatic detector sensitivity testing (NFPA-72 compliant).
- Maintenance alert (two levels).
- Self-optimizing pre-alarm.

**FSL-751 VIEW (VERY INTELLIGENT EARLY WARNING)**

**SMOKE DETECTION TECHNOLOGY**

- Advanced ONYX intelligent sensing algorithms differentiate between smoke and non-smoke signals (U.S. Patent 5,831,524).
- Addressable operation pinpoints the fire location.
- Early warning performance comparable to the best aspiration systems at a fraction of the lifetime cost.

**FAPT-851 ACCLIMATE® PLUS™**

**LOW-PROFILE INTELLIGENT MULTI-SENSOR**

- Detector automatically adjusts sensitivity levels without operator intervention or programming. Sensitivity increases with heat.
- Microprocessor-based technology; combination photo and thermal technology.
- Low-temperature warning signal at 40°F ± 5°F (4.44°C ± 2.77°C).

**FSC-851 INTELLIQUAD**

**ADVANCED MULTI-CRITERIA DETECTOR**

- Detects all four major elements of a fire (smoke, heat, CO, and flame).
- Automatic drift compensation of smoke sensor and CO cell.
- High nuisance-alarm immunity.

**FSA-8000 INTELLIGENT FAAST DETECTOR**

- Connects directly to the SLC loop of compatible ONYX series panels
- Provides five event thresholds that can be individually programmed with descriptive labels for control-by-event programming; uses five detector addresses.
- Uses patented particle separator and field-replaceable filter to remove contaminants.
- Advanced algorithms reject common nuisance conditions

**FCO-851 INTELLIQUAD™ PLUS**

**ADVANCED MULTI-CRITERIA FIRE/CO DETECTOR**

- Detects all four major elements of a fire.
- Separate signal for life-safety CO detection.

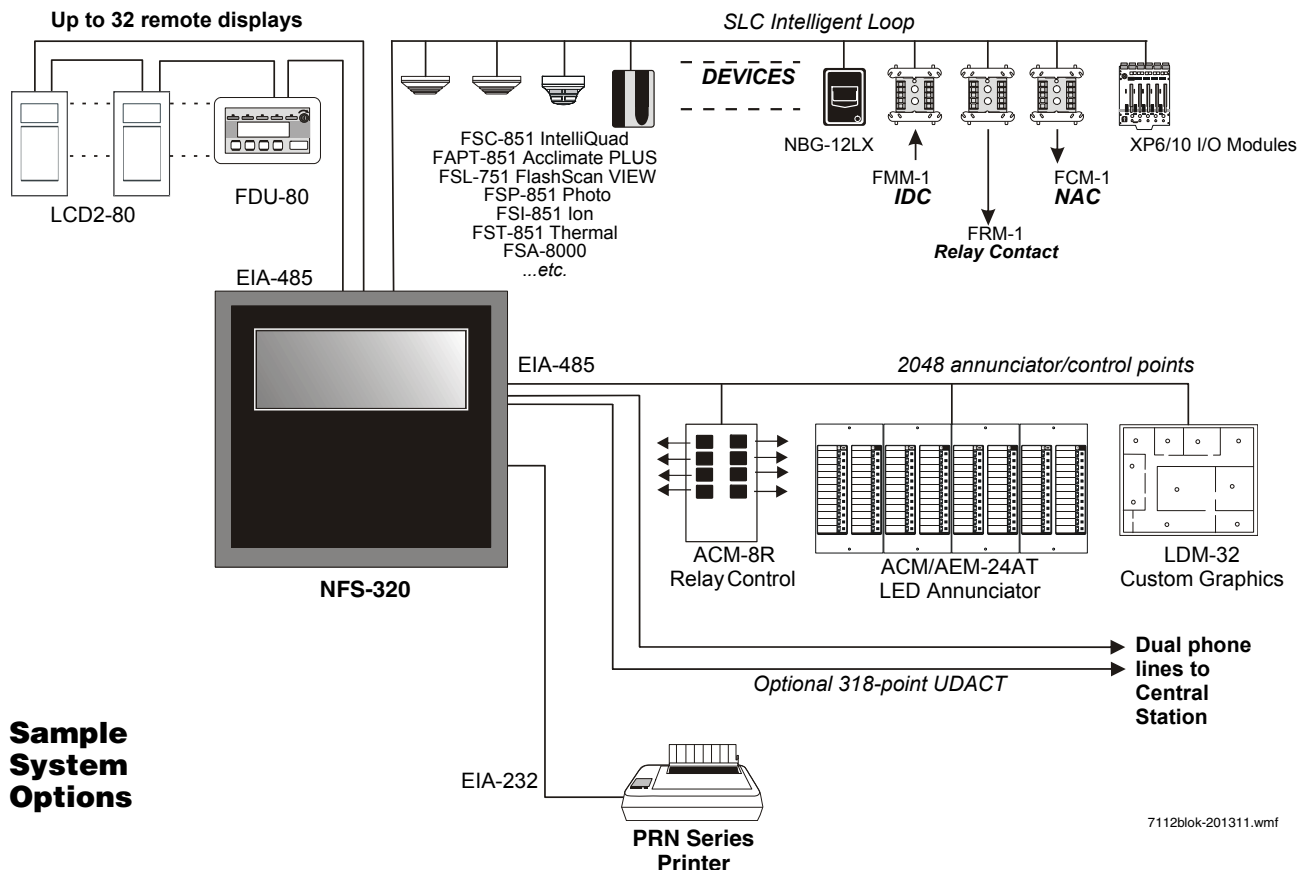

7112blok-201311.wmf

- Optional addressable sounder base for Temp-3 (fire) or Temp-4(CO) tone.
- Automatic drift compensation of smoke sensor and CO cell.
- High nuisance-alarm immunity.

#### **RELEASING FEATURES**

- Ten independent hazards.
- Sophisticated cross-zone (three options).
- Delay timer and Discharge timers (adjustable).
- Abort (four options).
- Low-pressure CO<sub>2</sub> listed.

#### **VOICE FEATURES**

- Integrates with FirstCommand Series. See DN-60772.
- Telephone applications require NFC-FFT.

#### **HIGH-EFFICIENCY OFFLINE SWITCHING**

##### **3.0 A POWER SUPPLY (6.0 A IN ALARM)**

- 120 VAC (NFS-320/NFS-320C); 240 VAC (NFS-320E).
- Displays battery current/voltage on panel (with display).

## **FlashScan, Exclusive World-Leading Detector Protocol**

At the heart of the NFS-320 is a set of detection devices and device protocol — FlashScan (U.S. Patent 5,539,389). FlashScan is an all-digital protocol that gives superior precision and high noise immunity.

In addition to providing quick identification of an active input device, this protocol can also activate many output devices in a fraction of the time required by competitive protocols. This high speed also allows the NFS-320 to have the largest device per loop capacity in the industry — 318 points — yet every input and output device is sampled in less than two seconds. The microprocessor-based FlashScan detectors have bicolor LEDs that can be coded to provide diagnostic information, such as device address during Walk Test.

## **ONYX Intelligent Sensing**

Intelligent sensing is a set of software algorithms that provides the NFS-320 with industry-leading smoke detection capability. These complex algorithms require many calculations on each reading of each detector, and are made possible by the high-speed microcomputer used by the NFS-320.

**Drift Compensation and Smoothing:** Drift compensation allows the detector to retain its original ability to detect actual smoke, and resist false alarms, even as dirt accumulates. It reduces maintenance requirements by allowing the system to automatically perform the periodic sensitivity measurements required by NFPA 72. Smoothing filters are also provided by software to remove transient noise signals, such as those caused by electrical interference.

**Maintenance Warnings:** When the drift compensation performed for a detector reaches a certain level, the performance of the detector may be compromised, and special warnings are given. There are three warning levels: (1) Low Chamber value; (2) Maintenance Alert, indicative of dust accumulation that is near but below the allowed limit; (3) Maintenance Urgent, indicative of dust accumulation above the allowed limit.

**Sensitivity Adjust:** Nine sensitivity levels are provided for alarm detection. These levels can be set manually, or can change automatically between day and night. Nine levels of

pre-alarm sensitivity can also be selected, based on predetermined levels of alarm. Pre-alarm operation can be latching or self-restoring, and can be used to activate special control functions.

**Self-Optimizing Pre-Alarm:** Each detector may be set for “Self-Optimizing” pre-alarm. In this special mode, the detector “learns” its normal environment, measuring the peak analog readings over a long period of time, and setting the pre-alarm level just above these normal peaks.

**Cooperating Multi-Detector Sensing:** A patented feature of ONYX intelligent sensing is the ability of a smoke sensor to consider readings from nearby sensors in making alarm or pre-alarm decisions. Without statistical sacrifice in the ability to resist false alarms, it allows a sensor to increase its sensitivity to actual smoke by a factor of almost two to one.

## **Field Programming Options**

**Autoprogram** is a timesaving feature. The FACP “learns” what devices are physically connected and automatically loads them in the program with default values for all parameters. Requiring less than one minute to run, this routine allows the user to have almost immediate fire protection in a new installation, even if only a portion of the detectors are installed.

**Keypad Program Edit (with KDM-R2)** The NFS-320, like all NOTIFIER intelligent panels, has the exclusive feature of program creation and editing capability from the front panel keypad, while continuing to provide fire protection. The architecture of the NFS-320 software is such that each point entry carries its own program, including control-by-event links to other points. This allows the program to be entered with independent per-point segments, while the NFS-320 simultaneously monitors other (already installed) points for alarm conditions.

VeriFire® Tools is an offline programming and test utility that can greatly reduce installation programming time, and increase confidence in the site-specific software. It is Windows®-based and provides technologically advanced capabilities to aid the installer. The installer may create the entire program for the NFS-320 in the comfort of the office, test it, store a backup file, then bring it to the site and download from a laptop into the panel.

## **Placement of Equipment in Chassis and Cabinet**

The following guidelines outline the NFS-320’s flexible system design.

**Wiring:** When designing the cabinet layout, consider separation of power-limited and non-power-limited wiring as discussed in the *NFS-320 Installation Manual*.

It is critical that all mounting holes of the NFS-320 are secured with a screw or standoff to ensure continuity of Earth Ground.

**Networking:** If networking two or more control panels, each unit requires a Network Communication Module or High-Speed Network Communication Module (HS-NCM) can support two nodes; see “Networking Options” on page 4). These modules can be installed in any option board position (see manual), and additional option boards can be mounted in front of them.

## KDM-R2 Controls and Indicators

**Program Keypad:** QWERTY type (keyboard layout).

**12 LED Indicators:** Power; Fire Alarm; Pre-Alarm; Security; Supervisory; System Trouble; Signals Silenced; Points Disabled; Control Active; Abort; Pre-Discharge; Discharge.

**Keypad Switch Controls:** Acknowledge/Scroll Display; Signal Silence; Drill; System Reset; Lamp Test.

**LCD Display:** 80 characters (2 x 40) with long-life LED backlight.

## Product Line Information

- “Configuration Guidelines” on page 4
- “Networking Options” on page 4
- “Auxiliary Power Supplies and Batteries” on page 4
- “Audio Options” on page 4
- “Compatible Devices, EIA-232 Ports” on page 4
- “Compatible Devices, EIA-485 Ports” on page 4
- “Compatible Intelligent Devices” on page 5
- “Enclosures, Chassis, and Dress Plates” on page 5
- “Other Options” on page 6

### CONFIGURATION GUIDELINES

The NFS-320 system ships assembled; description and some options follow. See “Enclosures, Chassis, and Dress Plates” on page 5 for information about mounting peripherals.

**NOTE:** Stand-alone and network systems require a main display. On stand-alone systems, the panel's keypad provides the required display. On network systems (two or more networked fire panel nodes), at least one NCA-2, NCS, or ONYXWorks annunciation device is required. (For NCA-2, see DN-7047.)

**NFS-320:** The standard, factory-assembled NFS-320 system includes the following components: one control panel mounted on chassis (120 V operation — ships with grounding cable, battery interconnect cables, and document kit); includes integral power supply mounted to the main circuit board; one primary display KDM-R2 keypad/display; and one cabinet for surface or semi-flush mounting. *Purchase batteries separately. One or two option boards may be mounted inside the NFS-320 cabinet; additional option boards can be used in remote cabinets. (Non-English versions also available. NFS-320-SP, NFS-320-PO.)*

**NFS-320R:** Same as NFS-320, but in red enclosure.

**NFS-320C:** Based on NFS-320 above. NFS-320C supports installation of an optional ACM-series annunciator in the same cabinet. UL- and ULC-listed. (Non-English version also available: NFS-320C-FR.) For NFS-320C, see DN-60085.

**NFS-320CR:** Same as NFS-320C but in a red enclosure. For NFS-320C, see DN-60085.

**NFS-320E:** Same as NFS-320, but with 240 V operation. (Non-English versions also available. NFS-320E-SP, NFS-320E-PO.)

**TR-320:** Trim ring for the NFS-320 cabinet.

### NETWORKING OPTIONS

**NCM-W, NCM-F:** Standard Network Communications Modules. Wire and multi-mode fiber versions available. See DN-6861.

**HS-NCM-W/MF/SF/WMF/WSF/MFSF:** High-speed Network Communications Modules. Wire, single-mode fiber, multi-

mode fiber, and media conversion models are available. See DN-60454.

**RPT-W, RPT-F, RPT-WF:** Standard-network repeater board with wire connection (RPT-W), multi-mode fiber connection (RPT-F), or allowing a change in media type between wire and fiber (RPT-WF). Not used with high-speed networks. See DN-6971.

**ONYXWorks:** UL-listed graphics PC workstation, software, and computer hardware. See DN-7048 for specific part numbers.

**NFN-GW-EM-3:** NFN Gateway, embedded. See DN-60499.

**NWS-3: NOTI•FIRE•NET™** Web Server. See DN-6928.

**CAP-GW:** Common Alerting Protocol Gateway. See DN-60576.

**VESDA-HLI-GW:** VESDAnet high-level interface gateway. See DN-60753.

**LEDSIGN-GW:** UL-listed sign gateway. Interfaces with classic and high-speed NOTI•FIRE•NET networks through the NFN Gateway. See DN-60679.

**OAX2-24V:** UL-listed LED sign, used with LEDSIGN-GW. See DN-60679.

### AUXILIARY POWER SUPPLIES AND BATTERIES

**ACPS-610:** 6.0 A or 10.0 A addressable charging power supply. See DN-60244.

**APS2-6R:** Auxiliary Power Supply. Provides up to 6.0 amperes of power for peripheral devices. Includes battery input and transfer relay, and overcurrent protection. Mounts on two of four positions on a CHS-4L or CHS-4 chassis. See DN-5952.

**FCPS-24S6/S8:** Remote 6 A and 8 A power supplies with battery charger. See DN-6927.

**BAT Series:** Batteries. NFS-320 uses two 12 volt, 18 to 200 AH batteries. See DN-6933.

### AUDIO OPTIONS

**NFC-50/100:** 25 watt, 25 VRMS, emergency Voice Evacuation Control Panel (VECP) with integral commercial microphone, digital message generator, and Class A or Class B speaker circuits. See DN-60772.

### COMPATIBLE DEVICES, EIA-232 PORTS

**PRN-6:** 80-column printer. See DN-6956.

**VS4095/5:** Printer, 40-column, 24 V. Mounted in external backbox. See DN-3260.

**DPI-232:** Direct Panel Interface, specialized modem for extending serial data links to remotely located FACP's and/or peripherals; mount on NFS-320 chassis. See DN-6870.

### COMPATIBLE DEVICES, EIA-485 PORTS

**ACM-24AT:** ONYX Series ACS annunciator — up to 96 points of annunciation with Alarm or Active LED, Trouble LED, and switch per circuit. Active/Alarm LEDs can be programmed (by powered-up switch selection) by point to be red, green, or yellow; the Trouble LED is always yellow. See DN-6862.

**AEM-24AT:** Same LED and switch capabilities as ACM-24AT, expands the ACM-24AT to 48, 72, or 96 points. See DN-6862.

**ACM-48A:** ONYX Series ACS annunciator — up to 96 points of annunciation with Alarm or Active LED per circuit. Active/Alarm LEDs can be programmed (by powered-up switch

selection) in groups of 24 to be red, green, or yellow. Expandable to 96 points with one AEM-48A. *See DN-6862.*

**AEM-48A:** Same LED capabilities as ACM-48A, expands the ACM-48A to 96 points. *See DN-6862.*

**ACM-8R:** Remote Relay Module with eight Form-C contacts. Can be located up to 6,000 ft. (1828.8 m) from panel on four wires. *See DN-3558.*

**FDU-80:** Terminal mode. 80-character, backlit LCD display. Mounts up to 6,000 ft. (1828.8 m) from panel. Up to 32 per FACP. *See DN-6820.*

**LCD2-80:** Terminal and ACS mode. 80-character, backlit LCD display. Mounts up to 6,000 ft. (1828.8 m) from panel. Up to 32 per FACP. *See DN-60548.*

**LDM:** Lamp Driver Modules LDM-32, LDM-E32, and LDM-R32; remote custom driver modules. *See DN-0551.*

**SCS:** Smoke control stations SCS-8, SCE-8, with lamp drivers SCS-8L, SCE-8L; eight (expandable to 16) circuits (HVAC only). *See DN-4818.*

**TM-4:** Transmitter Module. Includes three reverse-polarity circuits and one municipal box circuit; mount on NFS-320 chassis or remotely. *See DN-6860.*

**UDACT-2:** Universal Digital Alarm Communicator Transmitter, 636 channel. *See DN-60686.*

**UZZ-256:** Programmable Universal Zone Coder provides positive non-interfering successive zone coding. Microprocessor-controlled, field-programmable from IBM®-compatible PCs (requires optional programming kit). Mounts in **BB-UZZ**. *See DN-3404.*

#### **COMPATIBLE INTELLIGENT DEVICES**

**FSA-8000:** Intelligent FFAST Fire Alarm Aspiration Sensing Technology®. Intelligent aspirating smoke detector. For Canadian applications, order FSA-8000A. *See DN-60792.*

**FSB-200:** Intelligent beam smoke detector. *See DN-6985.*

**FSB-200S:** Intelligent beam smoke detector with integral sensitivity test. *See DN-6985.*

**FSC-851:** FlashScan IntelliQuad Advanced Multi-Criteria Detector. *See DN-60412.*

**FCO-851:** FlashScan IntelliQuad PLUS Advanced Multi-Criteria Fire/CO Detector. *See DN-60689.*

**FSI-851:** Low-profile FlashScan ionization detector. *See DN-6934.*

**FSP-851:** Low-profile FlashScan photoelectric detector. *See DN-6935.*

**FSP-851T:** Low-profile FlashScan photoelectric detector with 135°F (57°C) thermal. *See DN-6935.*

**FSP-851R:** Remote-test capable photoelectric detector for use with DNR(W) duct detector housings. *See DN-6935.*

**FST-851:** FlashScan thermal detector 135°F (57°C). *See DN-6936.*

**FST-851R:** FlashScan thermal detector 135°F (57°C) with rate-of-rise. *See DN-6936.*

**FST-851H:** FlashScan 190°F (88°C) high-temperature thermal detector. *See DN-6936.*

**FAPT-851:** FlashScan Acclimate Plus low-profile multi-sensor detector. *See DN-6937.*

**FSL-751:** FlashScan VIEW laser photo detector. *See DN-6886.*

**DNR:** InnovairFlex low-flow non-relay duct-detector housing (order FSP-851R separately). Replaces FSD-751PL/FSD-751RPL. *See DN-60429.*

**DNRW:** Same as above with NEMA-4 rating, watertight. *See DN-60429.*

**B224RB:** Low-profile relay base. *See DN-60054.*

**B224BI:** Isolator base for low-profile detectors. *See DN-60054.*

**B210LP:** Low-profile base. Standard U.S. style. Replaces B710LP. *See DN-60054.*

**B501:** European-style, 4" (10.16 cm) base. *See DN-60054.*

**B200S:** Intelligent programmable sounder base, capable of producing a variety of tone patterns including ANSI Temporal 3. Compatible with synchronization protocol. *See DN-60054.*

**B200SR:** Sounder base, Temporal 3 or Continuous tone. *See DN-60054.*

**FMM-1:** FlashScan monitor module. *See DN-6720.*

**FDM-1:** FlashScan dual monitor module. *See DN-6720.*

**FZM-1:** FlashScan two-wire detector monitor module. *See DN-6720.*

**FMM-101:** FlashScan miniature monitor module. *See DN-6720.*

**FCM-1:** FlashScan control module. *See DN-6724.*

**FCM-1-REL:** FlashScan releasing control module. *See DN-60390.*

**FRM-1:** FlashScan relay module. *See DN-6724.*

**FDRM-1:** FlashScan dual monitor/dual relay module. *See DN-60709.*

**NBG-12LX:** Manual pull station, addressable. *See DN-6726.*

**ISO-X:** Isolator module. *See DN-2243.*

**XP6-C:** FlashScan six-circuit supervised control module. *See DN-6924.*

**XP6-MA:** FlashScan six-zone interface module; connects intelligent alarm system to two-wire conventional detection zone. *See DN-6925.*

**XP6-R:** FlashScan six-relay (Form-C) control module. *See DN-6926.*

**XP10-M:** FlashScan ten-input monitor module. *See DN-6923.*

**SLC-IM:** SLC integration module, for VESDAnet detectors. *See DN-60755.*

#### **ENCLOSURES, CHASSIS, AND DRESS PLATES**

**CAB-BM Marine System:** Protects equipment in shipboard and waterfront applications. Also order **BB-MB** for systems using 100 AH batteries. For a full list of required and optional equipment, see *DN-60688.*

**BB-UZZ:** Backbox for housing the UZZ-256. Required for NFS-320 applications. Black. For red, order BB-UZZ-R.

**NFS-LBB:** Battery Box (required for batteries larger than 26 AH).

**NFS-LBBR:** Same as above, but red.

**SEISKIT-320/B26:** Seismic mounting kit. Required for seismic-certified applications with NFS-320 and BB-26. Includes battery bracket for two 26 AH batteries.



**SEISKIT-BB25:** Seismic mounting kit for the BB-25. Includes battery bracket for two 26 AH batteries.

**SEISKIT-LBB:** Seismic kit for the NFS-LBB. Includes battery bracket for two 55 AH batteries.

#### OTHER OPTIONS

**411:** Slave Digital Alarm Communicator. See DN-6619.

**411UDAC:** Digital Alarm Communicator. See DN-6746.

**IPDACT-2/2UD, IPDACT Internet Monitoring Module:** Connects to primary and secondary DACT telephone output ports for internet communications over customer-provided Ethernet connection. Requires compatible Teldat VisorALARM Central Station Receiver. Can use DHCP or static IP. See DN-60408.

**IPSPLT:** Y-adaptor option allow connection of both panel dialer outputs to one IPDACT-2/2UD cable input.

**IPENC:** External enclosure for IPDACT, includes IPBRKT mounting bracket; Red. For Black order **IPENC-B**.

**IPGSM-4G:** Internet and Digital Cellular Fire Alarm Communicator. Provides selectable configurable paths: cellular only, IP only, or IP primary with cellular backup. Connects to the primary and secondary ports of a DACT. See DH-60769.

**NFS-320-RB:** Replacement board with central processing unit (CPU). *NOTE: Keypad must be removed before shipping old unit out for repair.*

- NFS-320-RBE: Replacement CPU, Export.
- NFS-320-RB-PO: Replacement CPU, Portuguese.
- NFS-320-RB-POE: Replacement CPU, Export, Portuguese.
- NFS-320-RBC-FR: Replacement CPU, Canadian French.
- NFS-320-RB-SP: Replacement CPU, Spanish.
- NFS-320-RB-SPE: Replacement CPU, Export, Spanish.

*NOTE: For other options including compatibility with retrofit equipment, refer to the panel's installation manual, the SLC manual, and the Device Compatibility Document.*

## System Specifications

#### SYSTEM CAPACITY

- Intelligent Signaling Line Circuits ..... 1
- Intelligent detectors ..... 159
- Addressable monitor/control modules ..... 159
- Programmable internal hardware and output circuits ..... 4
- Programmable software zones ..... 99
- Special programming zones ..... 14
- LCD annunciators per NFS-320/-320E ..... 32
- ACS annunciators per NFS-320/-320E ..... 32 addresses x 64 points

#### SPECIFICATIONS

- Primary input power
  - NFS-320: 120 VAC, 50/60 Hz, 5.0 A.
  - NFS-320E: 220/240 VAC, 50/60 Hz, 2.5 A.

- Current draw (standby/alarm):
  - NFS-320(E) board: 0.250 A. Add 0.035 A for each NAC in use.
  - KDM-R2 (Backlight on): 0.100 A.
- Total output 24 V power: 6.0 A in alarm.

*NOTE: The power supply has a total of 6.0 A of available power. This is shared by all internal circuits. See Installation Manual for a complete current draw calculation sheet.*

- Standard notification circuits (4): 1.5 A each.
- Resettable regulated 24V power: 1.25 A.
- Two non-resettable regulated 24V power outputs:
  - 1.25 A.
  - 0.50 A.
- Non-resettable 5V power: 0.15 A.
- Battery charger range: 18 AH – 200 AH. Use separate cabinet for batteries over 26 AH.
- Float rate: 27.6 V.

#### CABINET SPECIFICATIONS

NFS-320 cabinet dimensions:

- Backbox: 18.12 in. (46.025 cm) width; 18.12 in. (46.025 cm) height; 5.81 in. (14.76 cm) depth.
- Door: 18.187 in. (46.195 cm) width; 18.40 in. (46.736 cm) height; 0.75 in. (1.905 cm) depth.
- Trim ring: Molding width is 0.905 in. (2.299 cm).
- Shipping weight (without batteries): 36.15 lb. (16.4 kg).

#### TEMPERATURE AND HUMIDITY RANGES

This system meets NFPA requirements for operation at 0 – 49°C/32 – 120°F and at a relative humidity 93% ± 2% RH (noncondensing) at 32°C ± 2°C (90°F ± 3°F). However, the useful life of the system's standby batteries and the electronic components may be adversely affected by extreme temperature ranges and humidity. Therefore, it is recommended that this system and its peripherals be installed in an environment with a normal room temperature of 15 – 27°C/ 60 – 80°F.

#### AGENCY LISTINGS AND APPROVALS

The listings and approvals below apply to the basic NFS-320 control panel. In some cases, certain modules may not be listed by certain approval agencies, or listing may be in process. Consult factory for latest listing status.

- **UL Listed:** S635.
- **ULC Listed:** S635 (NFS-320C only, excludes IPDACT).
- **FM Approved.**
- **CSFM:** 7165-0028:0243.
- **MEA:** 128-07-E.
- **FDNY:** COA#6085, #6121.
- **City of Chicago.**

*NOTE: For additional information on UL- and ULC-listed model NFS-320C, see DN-60085. For information on NFS-320SYS, see DN-60637.*

**Marine Applications:** Marine approved systems must be configured using components itemized in this document. (See Main System Components, in "Product Line Information.") Specific connections and requirements for those components are described in the installation document,

PN 54756. When these requirements are followed, systems are approved by the following agencies:

- **US Coast Guard** 161.002/50/0, 161.002/55/0 (Standard 46 CFR and 161.002).
- **Lloyd's Register** 11/600013 (ENV 3 category).
- **American Bureau of Shipping** (ABS) Type Approval.

**NOTE:** For information on marine applications, see DN-60688.

#### **STANDARDS**

The NFS-320 complies with the following UL Standards and NFPA 72, International Building Code (IBC), and California Building Code (CBC) Fire Alarm Systems requirements:

- **UL 864** (Fire).
- **UL 1076** (Burglary).
- **UL 2572** (Mass Notification Systems).
- **LOCAL** (Automatic, Manual, Waterflow and Sprinkler Supervisory).
- **AUXILIARY** (Automatic, Manual and Waterflow) (requires TM-4).
- **REMOTE STATION** (Automatic, Manual, Waterflow and Sprinkler Supervisory) (requires TM-4).
- **PROPRIETARY** (Automatic, Manual, Waterflow and Sprinkler Supervisory). *Not applicable for FM.*
- **CENTRAL STATION** (Automatic, Manual, Waterflow and Sprinkler Supervisory) (requires DACT).
- **EMERGENCY VOICE/ALARM.**
- **OT, PSDN** (Other Technologies, Packet-switched Data Network).
- **IBC 2012, IBC 2009, IBC 2006, IBC 2003, IBC 2000** (Seismic).
- **CBC 2007** (Seismic).

---

**NOTI•FIRE•NET™**, **IntelliQuad™**, and **ONYXWorks™** are trademarks; and **Acclimate® Plus™**, **FirstCommand®**, **FlashScan®**, **NOTIFIER®**, **ONYX®**, **VeriFire®**, and **VIEW®** are registered trademarks of Honeywell International Inc. **Microsoft®** and **Windows®** are registered trademarks of Microsoft Corporation. **IBM®** is a registered trademark of IBM Corporation.  
©2013 by Honeywell International Inc. All rights reserved. Unauthorized use of this document is strictly prohibited.



This document is not intended to be used for installation purposes.  
We try to keep our product information up-to-date and accurate.  
We cannot cover all specific applications or anticipate all requirements.  
All specifications are subject to change without notice.

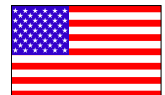

Made in the U.S. A.

For more information, contact Notifier. Phone: (203) 484-7161, FAX: (203) 484-7118.  
[www.notifier.com](http://www.notifier.com)

# UDACT-2

## Universal Digital Alarm Communicator Transmitter



Annunciator Control System

### General

The Universal Digital Alarm Communicator Transmitter (UDACT-2) is designed for use on Notifier Fire Alarm Control Panels and on the NCA-2 Network Control Annunciator. When used in conjunction with the NCA-2 network control annunciator, the UDACT-2 can report the status of all control panels on NOTI•FIRE•NET™. The UDACT-2 transmits system status to UL listed Central Station Receivers via the public switched telephone network. The UDACT-2 can be installed in the panel cabinet or remotely in a separate enclosure.

**NOTE:** The UDACT-2 can also be used with legacy panels. Please refer to the UDACT-2 manual for more information.

The UDACT-2 upload/download programming and firmware updates are accomplished with VeriFire Tools. Refer to the Programming Section for further details.

The UDACT-2 is capable of transmitting the status of software zones (Alarm and Trouble), System Trouble, Panel Off-Normal, Supervisory, Bell Trouble, Low Battery, and AC Fail. The UDACT-2 is capable of transmitting all of the zone and point status associated with each panel.

When the UDACT-2 is used with the NFS-3030, NFS2-3030, and NCA-2 it is capable of reporting up to 2,040 points. Reporting may be in the form of points or zones (refer to the UDACT-2 manual for specific reporting parameters). Points transmitted may be programmed for a variety of types, including fire, water-flow, supervisory, etc.

**NOTE:** Descriptions regarding point capacity, listed above, are for receivers which receive in Ademco Contact ID format. See chart on page 2 for compatible receivers.

### Features

- Programmable with VeriFire Tools version 6.60 or higher, allowing the UDACT-2 programming to be uploaded/downloaded and saved.
- Maximum of 14 point trouble messages transmitted per hour.
- Dual phone lines with line voltage detect.
- Compact in size: 6.75" x 4.25" (17.145 x 10.795 cm).
- USB port for upload/download programming.
- Manual Test Report function.
- Manual Transmission Clear function.
- Mounts in a separate enclosure (ABS-8RB or UBS-1B/R).
- Communicates vital system status including:
  - Independent zone fire alarm.
  - Independent zone non-fire alarm.
  - Independent zone trouble.
  - Independent zone supervisory.
  - AC (mains) Power Loss (programmable).
  - Low Battery and Earth Fault.
  - System Off-Normal.
  - 12 or 24 hour test signal.
  - Abnormal Test Signal per new UL requirements.
  - EIA-485 Communication Bus Failure.
- Annunciation of UDACT-2 Troubles including: loss of phone lines, communication failure with either Central Station, total communications failure.
- Individual LEDs for: Power, EIA-485 Loss, Manual Test, Kiss-off, Comm Fail, Primary Line Seize, Secondary Line Seize and Modem Communications.

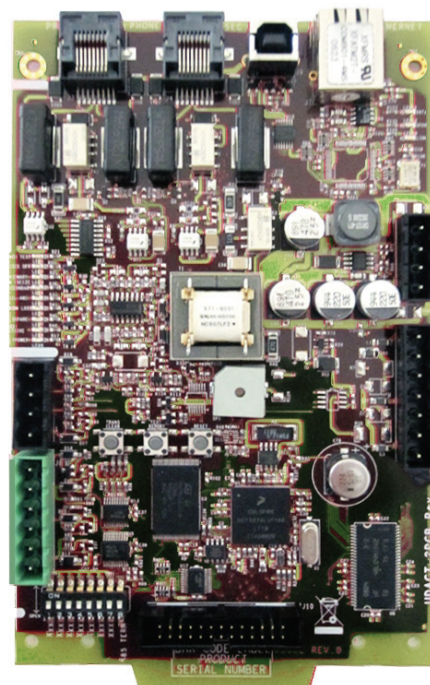

UDACT-2

- Open Collector relay driver for Total Communications Failure or UDACT-2 trouble.
- Real-time clock.
- Extensive transient protection.
- EIA-485 interface to host panel.

### Programming

The UDACT-2 programming is created and downloaded using VeriFire Tools. This enables the unit to be programmed prior to installation, be easily modified, and saved either online or offline. A printed report with point or zone information can be generated from VeriFire Tools for an ONYX Series panel or network annunciator. The point report consists of the central station point address, ACS point, ACS point function, panel label, panel point, type code, custom and extended label, alarm verification, walktest participation, presignal, and PAS information. The zone report consists of a grid with the central station point address, ACS point address, source, ACS point function, custom label and panel label. This report may be sent to the Central Station for their records. VeriFire Tools also supports upgrading the UDACT-2 operating firmware.

## Communication Formats

- Ademco Contact ID
- 4+2 Standard
- SIA

**NOTE:** Ademco Contact ID must be used for independent zone reporting.

## Type Mode Feature

Ademco Contact ID format - only Use Type Mode to identify reports to Central Station as:

- Fire Alarm
- Supervisory
- Pull Station
- Heat Detector
- Waterflow
- Duct Detector
- Flame Sensor
- Smoke Zone
- Burglary
- 24 hour Non-Burglary
- High Temperature
- Low Temperature
- Low Water Pressure
- Low Water Level
- Pump Failure

## Electrical Specifications

**Standby current:** 40 mA.

**Current while communicating:** 75 mA.

**Maximum current while communicating and with open collector output activated:** 100 mA.

**Voltage:** Regulated 24 volts. Range: 21.2 to 28.2 volts.

## Agency Listings and Approvals

In some cases, certain modules may not be listed by certain approval agencies, or listing may be in process. Consult factory for latest listing status.

- UL/ULC Listed: S635
- FM Approved
- CSFM: 7165-0028:0243 (NFS2-640/320), 7165-0028:0224 (NFS2-3030)
- FDNY: COA#6085, COA#6098

## Ordering Information

**UDACT-2:** Universal Digital Alarm Communicator Transmitter. Includes operating and programming instructions, and mounting hardware.

**MCBL-7:** DACT phone cord, 7 ft (2.13 m) long (two required).

**ABS-8RB:** Metal enclosure for externally mounting UDACT-2 up to 6,000 ft./1828.8 m from host FACP. 9.94" H x 4.63" W x 2.50" D (cm: 25.248 H x 11.760 W x 6.350 D).

**UBS-1B:** Metal enclosure with solid door, Black.

**UBS-1BR:** Metal enclosure with solid door, Red.

**R-10E:** SPDT Form-C relay. Contacts rated for 10 A @ 115 VAC. Connects to open collector relay driver.

**R-20E:** DPDT Two Form-C relays. Contacts rated for 10A @ 115 VAC. Connects to open collector relay driver.

**FBD-1:** Ferrite bead kit. Use for remote mounting only.

## UL Listed Receivers

The chart below shows UL listed receivers compatible with the UDACT-2. A check in the protocol column indicates the receiver supports that protocol.

Receiver	4+2 Standard 1800/2300	Ademco Contact ID	SIA
Ademco 685 (1)	✓	✓	
Ademco MX8000 (2)	✓	✓	✓
Silent Knight 9500 (3)	✓	✓	✓
Silent Knight 9800 (4)	✓	✓	✓
FBI CP220FB (5)	✓	✓	✓
Osborne Hoffman 2000E (6)		✓	✓
Radionics 6600 (7)		✓	✓
SurGard MLR2 (8)	✓	✓	
SurGard System III (9)		✓	✓
SurGard MLR-2000 (10)		✓	

(1) With 685-8 Line Card with Rev 4.4d software

(2) With 124060V206B and 124063 Line Card Rev B

(3) With version V2.4 Receiver & 126047 Line Card Rev G

(4) With 124077V2.00 Receiver & 126047 Line Card Rev M

(5) With software V3.9

(6) With V.7301 Receiver S/W

(7) With 01.01.03 Receiver S/W & Line Card 01.01.03

(8) With software V1.86

(9) With software V1.72

(10) With DSP4016 and V1.6 Line Card

NOTIFIRENET™ is a trademark and Notifier® is a registered trademark of Honeywell International Inc.  
©2012 by Honeywell International Inc. All rights reserved. Unauthorized use of this document is strictly prohibited.



This document is not intended to be used for installation purposes.  
We try to keep our product information up-to-date and accurate.  
We cannot cover all specific applications or anticipate all requirements.  
All specifications are subject to change without notice.



Made in the U.S. A.

For more information, contact Notifier. Phone: (203) 484-7161, FAX: (203) 484-7118.  
www.notifier.com

# FCPS-24S6(C/E) & FCPS-24S8(C/E)

## 6- & 8-Amp 24-Volt Remote Power Supplies



Power Supplies

### General

The FCPS-24S6E (6-amp) and FCPS-24S8E (8-amp) are remote power supplies with battery charger. The FCPS-24S6/-24S8 may be connected to any 12 or 24 volt fire alarm control panel (FACP) or may be used as stand-alone supplies. Primary applications include notification appliance circuit (NAC) expansion (to support ADA requirements and NAC synchronization) or auxiliary power to support 24 volt system accessories. The FCPS-24S6/-24S8 provides regulated and filtered 24 VDC power to four notification appliance circuits configured as either four Class B (Style Y) or Class A (Style Z, with ZNAC-4 option module). Alternately, the four outputs may be configured as all non-resettable, all resettable or two non-resettable and two resettable. The FCPS-24S6/-24S8 also contains a battery charger capable of charging up to 18 AH batteries. FCPS-24S6C & FCPS-24S8C are ULC-listed.

**NOTE:** Unless otherwise specified, the terms FCPS-24S6 and FCPS-24S8 used in this document refers to the standard FCPS-24S6 and FCPS-24S8, FCPS-24S6C and FCPS-24S8C, the FCPS-24S6E and FCPS-24S8E

### Features

- UL-Listed NAC synchronization using System Sensor, Wheelock, or Gentex "Commander<sup>2</sup>" appliances.
- Operates as a "sync-follower" or as a "sync-generator" (default). See note on page 2.
- Contains two fully-isolated input/control circuits - triggered from FACP NAC (NAC expander mode) or jumped permanently "ON" (stand-alone mode).
- Four Class B (Style Y) or four Class A (Style Z, with ZNAC-4 module) NACs.
- 6-amp (FCPS-24S6) or 8-amp (FCPS-24S8) full load output, with 3 amps maximum/circuit, in NAC expander mode (UL 864).
- 4-amp (FCPS-24S6) or 6-amp (FCPS-24S8) continuous output in stand-alone mode (UL 1481).
- Compatible with coded inputs; signals passed through.
- Optional power-supervision relay (EOLR-1).
- In stand-alone mode, output power circuits may be configured as: resettable, (reset line from FACP required), non-resettable, or a mix of two and two.
- Fully regulated and filtered power output - optimal for powering four-wire smoke detectors, annunciators, and other system peripherals requiring regulated/filtered power.
- Power-limiting technology meets UL power-limiting requirements.
- Form-C normally-closed trouble relay.
- Fully supervised power supply, battery, and NACs.
- Selectable earth fault detection.
- AC trouble report selectable for immediate 2-hour delay.
- Works with virtually any UL 864 fire alarm control which utilizes an industry-standard reverse-polarity notification circuit (including unfiltered and unregulated NAC power).
- Requires input trigger voltage of 9 - 32 VDC.
- Self-contained in compact, locking cabinet - 15"H x 14.5"W x 2.75"D (cm: 38.1H x 36.83W x 6.985D).



- Includes integral battery charger capable of charging up to 18 AH batteries. Cabinet capable of housing 7.0 AH batteries.
- Battery charger may be disabled via DIP switch for applications requiring larger batteries.
- Fixed, clamp-type terminal blocks accommodate up to 12 AWG (3.1mm<sup>2</sup>) wire.

### Specifications

#### Primary (AC) Power:

- FCPS-24S6C/-24S8C: 120 VAC, 60 Hz, 3.2A maximum.
- FCPS-24S6E/-24S8E: 240 VAC, 50 Hz, 1.6A maximum.
- Wire Size: minimum #14 AWG (2.0mm<sup>2</sup>) with 600 V insulation.

#### Control Input Circuit:

- **Trigger Input Voltage:** 9 to 32 VDC.
- **Trigger Current:** 2.0 mA (16 - 32 V); Per Input: 1.0 mA (9 - 16 V).

#### Trouble Contact Rating:

5 A at 24 VDC.

**Auxiliary Power Output:** Specific application power 500 mA maximum.

#### Output Circuits:

- +24 VDC filtered, regulated.
- 3.0 A maximum for any one circuit.
- Total continuous current for all outputs (stand-alone mode):
  - FCPS-24S6: 4.0 A maximum.
  - FCPS-24S8: 6.0 A maximum.
- Total short-term current for all outputs (NAC expander mode):
  - FCPS-24S6: 6.0 A maximum.
  - FCPS-24S8: 8.0 A maximum.

#### Secondary Power (Battery) Charging Circuit:

- Supports lead-acid batteries only.

- Float-charge voltage: 27.6 VDC.
- Maximum current charge: 1.5 A.
- Maximum battery capacity: 18 AH.

## Applications

**Example 1:** Expand notification appliance power an additional 6.0 A (FCPS-24S6) or 8.0 A (FCPS-24S8). Use up to four Class B (Style Y) outputs or four Class A (Style Z) outputs (using ZNAC-4). For example, the FACP notification appliance circuits will activate the FCPS when reverse-polarity activation occurs. Trouble conditions on the FCPS are sensed by the FACP through the notification appliance circuit.

**Example 2:** Use the FCPS to expand auxiliary regulated 24-volt system power up to 4.0 A (FCPS-24S6) or up to 6.0 A (FCPS-24S8). Both resettable and non-resettable power options are available. Resettable outputs are created by connecting the resettable output from the FACP to one or both of the FCPS inputs.

**Example 3:** Use addressable control modules to activate the FCPS instead of activating it through the FACP notification appliance circuits. This typically allows for mounting the FCPS at greater distances\* away from the FACP while expanding system architecture in various applications.

For example, an addressable control module is used to activate the FCPS, and an addressable monitor module is used to sense FCPS trouble conditions. Local auxiliary power output from the FCPS provides power to the addressable control module.

*\*NOTE: Addressable FACP's are capable of locating control and monitor modules at distances of up to 12,500 feet (3,810 meters).*

## Sync Follower/Generator Note

In some installations, it is necessary to synchronize the flash timing of all strobes in the system for ADA compliance. Strobes accomplish this by monitoring very short timing pulses on the NAC power which are created by the FACP. When installed at the end of a NAC wire run, the FCPS-24S6/-24S8 can track (i.e. "follow") the strobe synchronization timing pulses on the existing NAC wire run. This maintains the overall system flash timing of the additional strobes attaches to the FCPS.

When the FCPS-24S6/-24S8 is configured (via DIP switch settings) as a "sync follower," the FCPS's NAC outputs track the strobe synchronization pulses present at the FCPS's sync input terminal. The pulses originate from an upstream FACP or other power supply.

When the FCPS-24S6/-24S8 are configured (via DIP switch settings) as a "sync generator," the FCPS's sync input terminals are not used. Rather, the FCPS is the originator of the strobe synchronization pulses on the FCPS's NAC outputs. In "sync generator" mode, the sync type (System Sensor, Wheelock, or Gentex) is selectable via DIP switch settings.

## Standards and Codes

The FCPS-24S6 and FCPS-24S8 comply with the following standards:

- **NFPA 72** National Fire Alarm Code.
- **UL 864** Standard for Control Units for Fire Alarm Systems (NAC expander mode).
- **UL 1481** Power Supplies for Fire Alarm Systems.

## Agency Listings and Approvals

These listings and approvals apply to the modules specified in this document. In some cases, certain modules or applications may not be listed by certain approval agencies, or listing may be in process. Consult factory for latest listing status.

- **UL Listed:** S635, S674
- **ULC Listed:** S635 (FCPS-24S6C & FCPS-24S8C)
- **CSFM Approved:** 7315-0028:225
- **MEA:** 299-02-E
- **FM Approved**

## Ordering Information

**FCPS-24S6:** 6.0 A, 120 VAC remote charger power supply. Includes main printed circuit board, transformers, enclosure (15"H x 14.5"W x 2.75"D [cm: 38.1H x 36.83W x 6.985D]), and installation instructions.

**FCPS-24S6C:** Same as above, ULC-listed.

**FCPS-24S6R:** Same as FCPS-24S6 with red enclosure.

**FCPS-24S6E:** 6.0 A, 240 VAC remote charger power supply. Includes main printed circuit board, transformers, enclosure (15"H x 14.5"W x 2.75"D [cm: 38.1H x 36.83W x 6.985D]), and installation instructions.

**FCPS-24S8:** 8.0 A, 120 VAC remote charger power supply. Includes main printed circuit board, transformers, enclosure (15"H x 14.5"W x 2.75"D [cm: 38.1H x 36.83W x 6.985D]), and installation instructions.

**FCPS-24S8C** Same as above, ULC-listed.

**FCPS-24S8R:** Same as FCPS-24S8 with red enclosure.

**FCPS-24S8E:** 8.0 A, 240 VAC remote charger power supply. Includes main printed circuit board, transformers, enclosure (15"H x 14.5"W x 2.75"D [cm: 38.1H x 36.83W x 6.985D]), and installation instructions.

**ZNAC-4:** Class A (Style Y) NAC option module.

**EOLR-1:** 12/24 VDC end-of-line relay for monitoring four-wire smoke detector power.

**BAT-1270:** Battery, 12-volt, 7.0 AH (two required, see BAT Series data sheet DN-6933).

System Sensor® and NOTIFIER® are registered trademarks of Honeywell International Inc.

©2013 by Honeywell International Inc. All rights reserved. Unauthorized use of this document is strictly prohibited.



This document is not intended to be used for installation purposes.  
We try to keep our product information up-to-date and accurate.  
We cannot cover all specific applications or anticipate all requirements.  
All specifications are subject to change without notice.



Made in the U.S. A.

For more information, contact Notifier. Phone: (203) 484-7161, FAX: (203) 484-7118.  
www.notifier.com

# BAT Series Batteries

## Sealed Lead-Acid or Gell Cell



Power Supplies

### General

**BAT Series Batteries** feature a new part-numbering/listing system — providing an improved method of delivery for NOTIFIER-approved sealed lead-acid batteries for all your fire alarm system needs. Multiple brands of batteries are now offered under generic part numbers, reducing backorder situations and permitting us to deliver these products in a more timely fashion. NOTIFIER has approved the multiple brands listed below as possible product shipped for a given part number. Please note that any incoming orders for “PS Series” batteries will be converted to the equivalent BAT Series part numbers.



6933cov.jpg

### Features

- Provide secondary power for control panels.
- Sealed and maintenance-free.
- Overcharge protected.
- Easy handling with leakproof construction.
- Ruggedly constructed, high-impact case (ABS, polystyrene, or polypropylene, depending on models).
- Long service life.
- Compact design.

### Agency Listings and Approvals

The listings and approvals below apply to BAT Series Batteries. In some cases, certain modules may not be listed by certain approval agencies, or listing may be in process. Consult factory for latest listing status.

- **UL Recognized Components:** files MH19884 (*B & B Battery*), MH20567 (*UPG, previously Jolt*), MH20845 (*Power-Sonic*).

### Part Number Reference

CURRENT Part Number	BATTERY DESCRIPTION	ALTERNATES APPROVED: manufacturers and P/Ns shipped under BAT P/Ns
BAT-1250	12 V, 5 AH, sealed.	BP5-12 (B&B Battery); PS-1250 (Power-Sonic); SA1250 (Jolt) to be replaced with UB1250 (UPG).
BAT-1250	12 V, 5 AH, sealed.	BP5-12 (B&B Battery); PS-1250 (Power-Sonic); SA1250 (Jolt) to be replaced with UB1250 (UPG).
BAT-1270	12 V, 7 AH, sealed.	BP7-12 (B&B Battery); PS-1270 (Power-Sonic); SA1272 (Jolt) to be replaced with UB1270 (UPG).
BAT-12120	12 V, 12 AH, sealed.	BP12-12 (B&B Battery); PS-12120 (Power-Sonic); SA12120 (Jolt) to be replaced with UB12120 (UPG).
BAT-12180	12 V, 18 AH, sealed.	PS-12180 (Power-Sonic); SA12180 (Jolt) to be replaced with UB12180 (UPG).
BAT-12180	12 V, 18 AH, sealed.	PS-12180 (Power-Sonic); SA12180 (Jolt) to be replaced with UB12180 (UPG).
BAT-12260	12 V, 26 AH, sealed.	BP26-12 (B&B Battery); PS-12260 (Power-Sonic); SA12260 (Jolt) to be replaced with UB12260 (UPG).
BAT-12550	12 V, 55 AH, sealed.	PS-12550 (Power-Sonic); XSA12550 (Jolt) to be replaced with UB12550 (UPG).
BAT-12550	12 V, 55 AH, sealed.	PS-12550 (Power-Sonic); XSA12550 (Jolt) to be replaced with UB12550 (UPG).
BAT-121000	12 V, 100 AH, gell cell.	PS-121000 (Power-Sonic); XSA121000A (Jolt) to be replaced with UB121000 (UPG).



# POWER-SONIC

## Part Number Reference

1109t1.tbl

MODEL	Nominal Voltage V	Nominal Capacity @ 20 hr. rate A.H.	Discharge Current @20 hr. rate mA	DIMENSIONS									
				Width		Depth		Height		Height over terminal		Weight	
				in.	mm	in.	mm	in.	mm	in.	mm	lb.	kg.
PS-1250	12	5	250	3.54	90	2.76	70	4.02	102	4.21	107	4.1	1.9
PS-1270	12	7	325	5.94	151	2.56	65	3.7	94	3.86	98	5.7	2.6
PS-12120	12	12	600	5.94	151	3.86	98	3.7	94	3.86	98	8.8	4
PS-12180	12	18	875	7.13	181	2.99	76	6.57	167	6.57	167	12.8	5.8
PS-12250	12	25	1300	6.89	175	6.54	166	4.92	125	4.92	125	18.7	8.5
PS-12550	12	55	3000	10.25	260	6.6	168	8.2	208	9.45	240	39.7	18
PS-121000	12	100	5000	12	305	6.6	168	8.2	208	9.45	240	65.7	29.8

**Characteristic Discharge Curves**

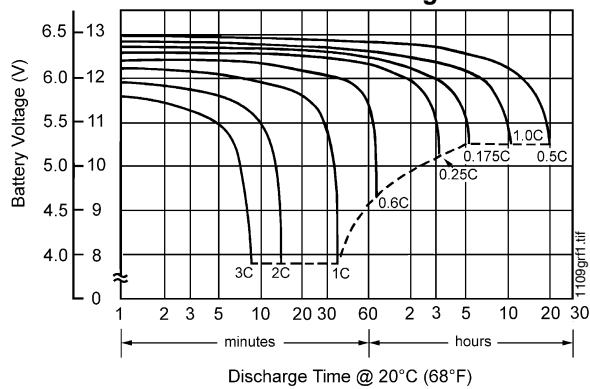

**Effect of Temperature on Capacity**

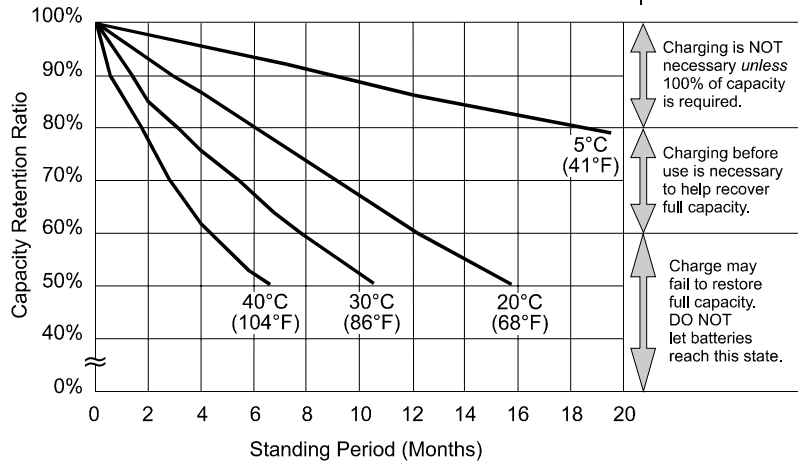
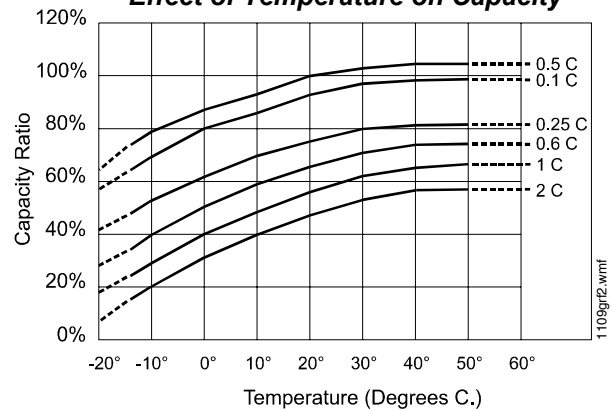

**at left:  
PS-121000  
Shelf-Life  
and Storage**

Charging is NOT necessary unless 100% of capacity is required.

Charging before use is necessary to help recover full capacity.

Charge may fail to restore full capacity. DO NOT let batteries reach this state.

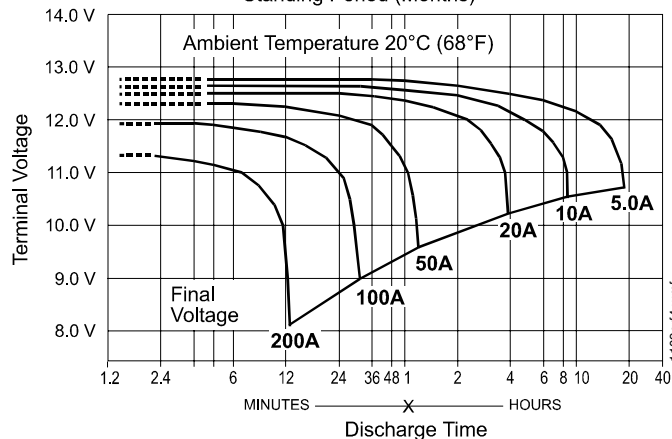

**at left:  
PS-121000  
Discharge  
Characteristics**

# FSP-851(A) Series

## Intelligent Plug-In Photoelectric Smoke Detectors with FlashScan®



Intelligent/Addressable Devices

### General

Notifier FSP-851(A) Series intelligent plug-in smoke detectors with integral communication provide features that surpass conventional detectors. Detector sensitivity can be programmed in the control panel software. Sensitivity is continuously monitored and reported to the panel. Point ID capability allows each detector's address to be set with rotary, decimal address switches, providing exact detector location for selective maintenance when chamber contamination reaches an unacceptable level. The FSP-851(A) photoelectric detector's unique optical sensing chamber is engineered to sense smoke produced by a wide range of combustion sources. Dual electronic thermistors add 135°F (57°C) fixed-temperature thermal sensing on the FSP-851T(A). The FSP-851R(A) is a remote test capable detector for use with DNR(A)/DNRW duct detector housings. FSP-851(A) series detectors are compatible with Notifier Onyx and CLIP series Fire Alarm Control Panels (FACPs).

**FlashScan®** (U.S. Patent 5,539,389) is a communication protocol developed by Notifier that greatly increases the speed of communication between analog intelligent devices. Intelligent devices communicate in a grouped fashion. If one of the devices in the group has new information, the panel's CPU stops the group poll and concentrates on single points. The net effect is response speed greater than five times that of earlier designs.

### Features

- Sleek, low-profile design.
- Addressable-analog communication.
- Stable communication technique with noise immunity.
- Low standby current.
- Two-wire SLC connection.
- Compatible with FlashScan® and CLIP protocol systems.
- Rotary, decimal addressing (1-99 on CLIP systems, 1-159 on FlashScan systems).
- Optional remote, single-gang LED accessory.
- Dual LED design provides 360° viewing angle.
- Visible bi-color LEDs blink green every time the detector is addressed, and illuminate steady red on alarm (*FlashScan systems only*).
- Remote test feature from the panel.
- Walk test with address display (an address on 121 will blink the detector LED: 12-[pause]-1 (*FlashScan systems only*)).
- Built-in functional test switch activated by external magnet.
- Built-in tamper-resistant feature.
- Sealed against back pressure.
- Constructed of off-white fire-resistant plastic, designed to commercial standards, and offers an attractive appearance.
- 94-5V plastic flammability rating.
- SEMS screws for wiring of the separate base.
- Optional relay, isolator, and sounder bases.

### Specifications

**Sensitivity:** 0.5% to 2.35% per foot obscuration

**Size:** 2.1" (5.3 cm) high; base determines diameter.

- **B210LP(A):** 6.1" (15.5 cm) diameter.
- **B501(A):** 4.1" (10.4 cm) diameter.
- **B200S(A):** 6.875" (17.46 cm) diameter.



FSP-851(A) in B210LP(A) Base

B210-2951.jpg

- **B200SR(A):** 6.875" (17.46 cm) diameter.
- **B224RB(A):** 6.2" (15.748 cm) diameter.
- **B224BI(A):** 6.2" (15.748 cm) diameter.

**Shipping Weight:** 5.2oz. (147g).

**Operating Temperature range:** FSP-851(A), 0°C to 49°C (32°F to 120°F). FSP-851T(A), 0°C to 38°C (32°F to 100°F). Low temperature signal for FSP-851T(A) at 45°F +/- 10°F (7.22°C +/- 5.54°C). FSP-851R(A) installed in a DNR(A)/DNRW, -20°C to 70°C (-4°F to 158°F).

**UL/ULC Listed Velocity Range:** 0-4000 ft/min. (1219.2 m/min.), suitable for installation in ducts.

**Relative Humidity:** 10%-93% noncondensing.

**Thermal Ratings:** Fixed-temperature setpoint 135°F (57°C).

### DETECTOR SPACING AND APPLICATIONS

Notifier recommends spacing detectors in compliance with NFPA 72. In low airflow applications with smooth ceiling, space detectors 30 feet (9.144m) for ceiling heights 10 feet (3.148m) and higher. For specific information regarding detector spacing, placement, and special applications refer to NFPA 72. *System Smoke Detector Application Guide*, document A05-1003, is available at [systemsensor.com](http://systemsensor.com)

### ELECTRICAL SPECIFICATIONS

**Voltage Range:** 15-32 volts DC peak.

**Standby Current (max. avg.):** 300µA @ 24VDC (one communication every five seconds with LED enabled).

**LED Current (max.):** 6.5mA @ 24 VDC ("ON").

### Installation

FSP-851(A) plug-in detectors use a separate base to simplify installation, service, and maintenance. A special tool allows maintenance personnel to plug in and remove detectors without using a ladder.

Mount base (all base types) on an electrical backbox which is at least 1.5" (3.81 cm) deep. For a chart of compatible junction boxes, see *DN-60054*.

**NOTE:** 1) Because of inherent supervision provided by the SLC loop, end-of-line resistors are not required. Wiring "T-taps" or branches are permitted for Style 4 (Class "B") wiring. 2) When using relay or sounder bases, consult the ISO-X(A) installation

sheet 156-1380 for device limitations between isolator modules and isolator bases.

## Agency Listings and Approvals

These listings and approvals apply to the modules specified in this document. In some cases, certain modules or applications may not be listed by certain approval agencies, or listing may be in process. *Consult factory for latest listing status.*

- **UL Listed:** S1115.
- **ULC Listed:** S1115 (FSP-851A, FSP-851RA, FSP-851TA).
- **MEA Listed:** 225-02-E .
- **FM Approved.**
- **CSFM:** 7272-0028:0206 .
- **Maryland State Fire Marshal:** Permit # 2122 .
- **BSMI:** CI313066760036.
- **CCCF:** Certif. # 2004081801000017 (FSP-851T)  
Certif. # 2004081801000016 (FSP-851).
- **U.S. Coast Guard:** 161.002/42/1 (NFS-640); 161.002/50/0 (NFS2-640/NFS-320/NFS-320C, excluding B210LP(A)).
- **Lloyd's Register:** 11/600013 (NFS2-640/NFS-320/NFS-320C, excluding B210LP(A)).

## Product Line Information

**NOTE:** "A" suffix indicates ULC Listed model.

**FSP-851:** Low-profile intelligent photoelectric sensor. Must be mounted to one of the bases listed below.

**FSP-851A:** Same as FSP-851 but with ULC listing.

**FSP-851T:** Same as FSP-851 but includes a built-in 135°F (57°C) fixed-temperature thermal device.

**FSP-851TA:** Same as FSP-851T but with ULC listing.

**FSP-851R:** Low-profile intelligent photoelectric sensor, remote test capable. For use with DNRA/DNRW.

**FSP-851RA:** Same as FSP-851R but with ULC listing. For use with DNRA.

## INTELLIGENT BASES

**NOTE:** "A" suffix indicates ULC Listed model.

**NOTE:** For details on intelligent bases, see DN-60054.

**B210LP(A):** Standard U.S. flanged low-profile mounting base.

**B210LPBP:** Bulk pack of B210LP; package contains 10.

**B501(A):** Standard European flangeless mounting base.

**B501BP:** Bulk pack of B501; package contains 10.

**B200S(A):** Intelligent, programmable sounder base capable of producing sound output in high or low volume with ANSI Temporal 3, ANSI Temporal 4, continuous tone, marching tone, and custom tone.

**B200SR(A):** Intelligent sounder base capable of producing sound output with ANSI Temporal 3 or continuous tone. Replaces B501BH series bases in retrofit applications.

**B224RB(A):** Plug-in System Sensor **relay** base. Screw terminals: up to 14 AWG (2.0 mm<sup>2</sup>). Relay type: Form-C. Rating: 2.0 A @ 30 VDC resistive; 0.3 A @ 110 VDC inductive; 1.0 A @ 30 VDC inductive.

**B224BI(A):** Plug-in System Sensor **isolator** detector base. Maximum 25 devices between isolator bases .

## ACCESSORIES

**F110:** Retrofit flange to convert B210LP(A) to match the B710LP(A) profile, or to convert older high-profile bases to low-profile.

**F110BP:** Bulk pack of F110; package contains 15.

**F210:** Replacement flange for B210LP(A) base.

**RA100Z(A):** Remote LED annunciator. 3 – 32 VDC. Mounts to a U.S. single-gang electrical box. For use with B501(A) and B210LP(A) bases only.

**SMB600:** Surface mounting kit

**M02-04-00:** Test magnet.

**M02-09-00:** Test magnet with telescoping handle.

**XR2B:** Detector removal tool. Allows installation and/or removal of detector heads from bases in high ceiling applications.

**XP-4:** Extension pole for XR2B. Comes in three 5-foot (1.524 m) sections.

**T55-127-010:** Detector removal tool without pole.

**BCK-200B:** Black detector covers for use with FSP-851(A) only; box of 10.

**WCK-200B:** White detector covers for use with FSP-851(A) only; box of 10.

-Notifier® and FlashScan® are registered trademarks of Honeywell International Inc.

©2011 by Honeywell International Inc. All rights reserved. Unauthorized use of this document is strictly prohibited.



This document is not intended to be used for installation purposes.  
We try to keep our product information up-to-date and accurate.  
We cannot cover all specific applications or anticipate all requirements.  
All specifications are subject to change without notice.



Made in the U.S. A.

For more information, contact Notifier. Phone: (203) 484-7161, FAX: (203) 484-7118.  
[www.notifier.com](http://www.notifier.com)

# FCO-851(A) IntelliQuad™ PLUS

## Advanced Multi-Criteria Fire/CO Detector



Intelligent/Addressable Devices

### General

World-class fire and carbon monoxide (CO) detection combined in a single addressable device provides a practical solution for today's market.

The IntelliQuad PLUS FCO-851(A) Advanced Multi-Criteria Fire/CO Detector is a plug-in, addressable device that provides both fire and carbon monoxide (CO) detection. For fire, the detector combines four separate sensing elements in one unit (smoke, CO, light/flare, and heat) to sense multiple components of a fire. This approach enables enhanced sensitivity to real fire with heightened immunity to nuisance particulate. For CO, the detector's electrochemical sensing cell creates a separate signal for life safety CO detection.

CO is a colorless, odorless, and deadly gas that is virtually impossible to detect with the human senses. It is released whenever carbon-based fuels (from fossil fuels to firewood) burn without enough oxygen to form CO<sub>2</sub>. Because the potential exists for dangerous levels of CO to accumulate in almost any building, legislation mandating the use of CO detection in commercial spaces continues to increase across the U.S. and Canada. The FCO-851(A) is listed to the UL 268 standard for smoke detectors and the UL 2075 standard for system-connected life safety carbon monoxide monitoring.

The FCO-851(A) should be used in conjunction with the B200S(COA) intelligent sounder base, which can generate either a Temp 3 pattern for fire or a Temp 4 pattern for CO alarm indication.

The B200S(COA) recognizes the System Sensor synchronization protocol. This enables it to be used as a component of the general evacuation signal — along with other System Sensor horns, horn strobes, and chimes — when connected to a power supply or Fire Alarm Control Panel (FACP) output capable of generating the System Sensor synchronization pulses. With each sounder base carrying a unique address, the FACP can then command an individual sounder — or a group of sounders — to activate. The command set from the panel can be tailored to the specific event, allowing selection of volume, tone, and group.

**NOTE:** The FCO-851(A) is compatible with the NFS-320(C), NFS-320SYS, NFS2-640, and NFS2-3030 operating with firmware version 17.0 (or higher) in FlashScan® mode; CLIP mode not supported.

### Features

- Unique ability to detect all four major elements of a fire.
- Separate CO detection signal.
- Highest nuisance alarm immunity.
- Automatic drift compensation of smoke sensor and CO cell.
- Uses only one address on the SLC.
- RealTest® CO testing capability.
- Separates audible signal for fire or CO alarm when used with the B200S base (B200SCOA in Canada).
- CO cell end-of-life warning and fault.
- FlashScan operation.



60689cov.JPG

FCO-851(A) in B200S(COA) Sounder Base

### Sensitivity Settings and Suggested Applications

- **Level 1:** 1% / ft of smoke. Suggested for very clean environments such as laboratories.
- **Level 2:** 2% / ft of smoke. Suggested for clean environments such as offices.
- **Level 3:** 3% / ft of smoke. Suggested for moderately clean environments such as hotel rooms, dorm rooms.
- **Level 4:** 3% / ft of smoke with different algorithm processing and weighting of sensor elements. Suggested for hotel rooms near a shower, boiler rooms.
- **Level 5:** 4% / ft of smoke. Suggested for equipment rooms, kitchens, paint shops.
- **Level 6:** Thermal alarm at 135°F (57°C).

Once the CO cell has reached end-of-life, the CO sensor no longer provides life safety protection; however, when the fire detector enters Photo, Thermal, Infrared (PTIR) mode, the following sensitivities apply:

- **Level 1:** 1% / ft of smoke. Suggested for very clean environments such as laboratories.
- **Level 2:** 2% / ft of smoke. Suggested for clean environments such as offices.
- **Level 3:** 3% / ft of smoke. Suggested for moderately clean environments such as hotel rooms, dorm rooms.
- **Level 6:** Thermal alarm at 135°F (57°C).

### Specifications

#### PHYSICAL SPECIFICATIONS

**Size:** 3.46" (8.79 cm) high x 6.875" (17.46 cm) diameter installed in B200S(COA) base.

**Shipping weight:** 4.6 oz. (130.41 g).

**Color:** Ivory.

**Operating humidity range:** 15% – 90% relative humidity (noncondensing).

**Operating temperature:** 0°C to 38°C (32°F to 100°F).

**Air velocity:** 0 – 4000 ft./min. (0 to 20 m/sec.).

### **ELECTRICAL SPECIFICATIONS**

**Operating Voltage range:** 15 – 32 volts VDC.

**Standby current (max. avg.):** 300 µA at 24 VDC (one communication every 5 seconds with LED blink enabled).

**Maximum Alarm Current (LED on):** 7.2 mA at 24 VDC.

### **CO ALARM ACTIVATION LEVELS**

Alarm activation levels as defined by UL Standard 2034:

Concentration of CO	Maximum Alarm Time Response
70 (+/- 5) PPM	240 min (not less than 60 min)
150 (+/- 5) PPM	50 min (not less than 10 min)
400 (+/- 10) PPM	15 min (not less than 4 min)

## **Ordering Information**

**NOTE:** "A suffix indicates ULC listed model.

**FCO-851:** IntelliQuad PLUS Advanced Multi-Criteria Fire/CO Detector.

**FCO-851A:** IntelliQuad PLUS Advanced Multi-Criteria Fire/CO Detector, ULC listed.

**B200S:** Intelligent programmable sounder base.

**B200SCOA:** Intelligent programmable sounder base, ULC listed. Includes CO detector markings in English and French.

**M02-04-00:** Detector Test Magnet.

**M02-09-00:** Telescoping Test Magnet.

## **Agency Listings and Approvals**

The listings and approvals below apply to the primary product. In some cases, certain modules may not be listed by certain approval agencies, or listing may be in process. Consult factory for latest listing status.

- **UL:** S1115 (FCO-851).
- **ULC:** S1115 (FCO-851A).
- **CSFM:** 7275-0028:0264.

IntelliQuad™ is a trademark and NOTIFIER®, RealTest® and FlashScan® are registered trademarks of Honeywell International Inc. ©2012 by Honeywell International Inc. All rights reserved. Unauthorized use of this document is strictly prohibited.



This document is not intended to be used for installation purposes.  
We try to keep our product information up-to-date and accurate.  
We cannot cover all specific applications or anticipate all requirements.  
All specifications are subject to change without notice.



Made in the U.S. A.

For more information, contact Notifier. Phone: (203) 484-7161, FAX: (203) 484-7118.  
[www.notifier.com](http://www.notifier.com)

# FST-851(A) Series

## Intelligent Thermal (Heat) Detectors with FlashScan®



Intelligent / Addressable Devices

### General

Notifier FST-851(A) Series intelligent plug-in thermal detectors with integral communication has features that surpass conventional detectors. Point ID capability allows each detector's address to be set with rotary, decimal address switches, providing exact detector locations. FST-851(A) Series thermal detectors use an innovative thermistor sensing circuit to produce 135°F/57°C fixed-temperature (FST-851/A) and rate-of-rise thermal detection (FST-851R/A) in a low-profile package. FST-851H(A) provides fixed high-temperature detection at 190°F/88°C. These thermal detectors provide effective, intelligent property protection in a variety of applications. FST-851(A) Series detectors are compatible with Notifier Onyx and CLIP series Fire Alarm Control Panels (FACPs).

FlashScan® (U.S. Patent 5,539,389) is a communication protocol developed by Notifier Engineering that greatly enhances the speed of communication between analog intelligent devices and certain NOTIFIER systems. Intelligent devices communicate in a grouped fashion. If one of the devices within the group has new information, the panel's CPU stops the group poll and concentrates on single points. The net effect is response speed greater than five times that of earlier designs.

### Features

- Sleek, low-profile, stylish design.
- State-of-the-art thermistor technology for fast response.
- Rate-of-rise model (FST-851R/A), 15°F (8.3°C) per minute.
- Factory preset fixed temperature at 135°F (57°C); high-temperature model fixed at 190°F (88°C).
- Addressable by device.
- Compatible with FlashScan® and CLIP protocol systems.
- Rotary, decimal addressing (1-99 on CLIP systems, 1-159 on FlashScan systems).
- Two-wire SLC connection.
- Visible LEDs "blink" every time the unit is addressed.
- 360°-field viewing angle of the visual alarm indicators (two bi-color LEDs). LEDs blink green in Normal condition and turn on steady red in Alarm.
- Integral communications and built-in device-type identification.
- Remote test feature from the panel.
- Built-in functional test switch activated by external magnet.
- Walk test with address display (an address of 121 will blink the detector LED 12-(pause)-1).
- Low standby current.
- Backward-compatible.
- Built-in tamper-resistant feature.
- Designed for direct-surface or electrical-box mounting.
- Sealed against back pressure.
- Plugs into separate base for ease of installation and maintenance. Separate base allows interchange of photoelectric, ionization and thermal sensors.
- SEMS screws for wiring of the separate base.
- Constructed of off-white fire-resistant plastic, designed to commercial standards, and offers an attractive appearance.



FST-851(A) in B210LP(A) Base

B210-2251.jpg

- 94-5V plastic flammability rating.
- Remote LED output connection to optional RA100Z(A) remote LED annunciator.
- Optional sounder, relay, and isolator bases.
- Optional flanged surface mounting kit.

### Specifications

**Size:** 2.1" (5.3 cm) high; base determines diameter.

- **B210LP(A):** 6.1" (15.5 cm) diameter.
- **B501(A):** 4.1" (10.4 cm) diameter.
- **B200S(A):** 6.875" (17.46 cm) diameter.
- **B200SR(A):** 6.875" (17.46 cm) diameter.
- **B224RB(A):** 6.2" (15.748 cm) diameter.
- **B224BI(A):** 6.2" (15.748 cm) diameter.

**Shipping weight:** 4.8 oz. (137 g).

**Operating temperature range:** FST-851(A) Series, FST-851R(A): -20°C to 38°C (-4°F to 100°F); FST-851H(A): -20°C to 66°C (-4°F to 150°F).

**Detector spacing:** UL approved for 50 ft. (15.24 m) center to center. FM approved for 25 x 25 ft. (7.62 x 7.62 m) spacing.

**Relative humidity:** 10% – 93% noncondensing.

**Thermal ratings:** fixed-temperature setpoint 135°F (57°C), rate-of-rise detection 15°F (8.3°C) per minute, high temperature heat 190°F (88°C).

### ELECTRICAL SPECIFICATIONS

**Voltage range:** 15 - 32 volts DC peak.

**Standby current (max. avg.):** 300 µA @ 24 VDC (one communication every 5 seconds with LED enabled).

**LED current (max.):** 6.5 mA @ 24 VDC ("ON").

### Applications

Use thermal detectors for protection of property. For further information, go to [systemsensor.com](http://systemsensor.com) for manual I56-407-00, Applications Manual for System Smoke Detectors, which provides detailed information on detector spacing, placement, zoning, wiring, and special applications.

## Installation

The FST Series plug-in intelligent thermal detectors use a separate base to simplify installation, service, and maintenance. Installation instructions are shipped with each detector. A special tool allows maintenance personnel to plug in and remove detectors without using a ladder.

Mount base (all base types) on an electrical backbox which is at least 1.5" (3.81 cm) deep. For a chart of compatible junction boxes, see *DN-60054*.

**NOTE: 1)** Because of the inherent supervision provided by the SLC loop, end-of-line resistors are not required. Wiring "T-taps" or branches are permitted for Style 4 (Class "B") wiring. **2)** When using relay or sounder bases, consult the ISO-X(A) installation sheet 156-1380 for device limitations between isolator modules and isolator bases.

## Agency Listings and Approvals

These listings and approvals apply to the modules specified in this document. In some cases, certain modules or applications may not be listed by certain approval agencies, or listing may be in process. Consult factory for latest listing status.

- **UL Listed:** S747.
- **ULC Listed:** S6978.
- **MEA Listed:** 383-02-E.
- **FM Approved.**
- **CSFM:** 7270-0028:0196.
- **BSMI:** CI313066760025.
- **CCCF:** Certif. # 2004081801000018.
- **U.S. Coast Guard:** 161.002/42/1 (NFS-640); 161.002/50/0 (NFS2-640/NFS-320/NFS-320C, excluding B210LP(A)).
- **Lloyd's Register:** 11/600013 (NFS-640/NFS-320/NFS-320C, excluding B210LP(A)).

## Product Line Information

**NOTE:** "A" suffix indicates ULC Listed model.

**FST-851:** Intelligent thermal detector. Must be mounted to one of the bases listed below.

**FST-851A:** Same as FST-851 but with ULC Listing.

**FST-851R:** Intelligent thermal detector with rate-of-rise feature.

**FST-851RA:** Same as FST-851R but with ULC Listing.

**FST-851H:** Intelligent high-temperature thermal detector.

**FST-851HA:** Same as FST-851H but with ULC Listing.

## INTELLIGENT BASES

**NOTE:** "A" suffix indicates ULC Listed model.

**NOTE:** For details about intelligent bases and their mounting, see *DN-60054*.

**B210LP(A):** Standard U.S. flanged low-profile mounting base.

**B210LPBP:** Bulk pack of B210LP; package contains 10.

**B501(A):** Standard European flangeless mounting base.

**B501BP:** Bulk pack of B501; package contains 10.

**B200S(A):** Addressable Intelligent, programmable sounder base capable of producing sound output in high or low volume

with ANSI Temporal 3, ANSI Temporal 4, continuous tone, marching tone, and custom tone.

**B200SR(A):** Intelligent sounder base capable of producing sound output with ANSI Temporal 3 or continuous tone. Replaces B501BH series bases in retrofit applications.

**B224RB(A):** Intelligent relay base. Screw terminals: up to 14 AWG (2.0 mm<sup>2</sup>). Relay type: Form-C. Rating: 2.0 A @ 30 VDC resistive; 0.3 A @ 110 VDC inductive; 1.0 A @ 30 VDC inductive.

**B224BI(A):** Intelligent isolator base. Isolates SLC from loop shorts. Maximum: 25 devices between isolator bases; see Note 2 under Installation.

## ACCESSORIES

**F110:** Retrofit flange to convert B210LP(A) to match the B710LP(A) profile, or to convert older high-profile bases to low-profile.

**F110BP:** Bulk pack of F110; package contains 15.

**F210:** Replacement flange for B210LP(A) base.

**RA100Z(A):** Remote LED annunciator. 3 – 32 VDC. Fits U.S. single-gang electrical box. Supported by B210LP(A) and B501(A) bases only.

**SMB600:** Surface mounting kit, flanged.

**M02-04-00:** Test magnet.

**M02-09-00:** Test magnet with telescoping handle.

**XR2B:** Detector removal tool. Allows installation and/or removal of FlashScan® Series detector heads from base in high ceiling installations. Includes T55-127-010.

**T55-127-010:** Detector removal tool without pole.

**XP-4:** Extension pole for XR2B. Comes in three 5-foot (1.524 m) sections.

Notifier® and FlashScan® are registered trademarks of Honeywell International Inc.

©2011 by Honeywell International Inc. All rights reserved. Unauthorized use of this document is strictly prohibited.



This document is not intended to be used for installation purposes.  
We try to keep our product information up-to-date and accurate.  
We cannot cover all specific applications or anticipate all requirements.  
All specifications are subject to change without notice.



For more information, contact Notifier. Phone: (203) 484-7161, FAX: (203) 484-7118.  
[www.notifier.com](http://www.notifier.com)

# Intelligent Bases

**B501(A), B200S(A), B200SR(A),  
B210LP(A), B2241BI(A), B224RB(A),  
Mounting Kits, and Accessories**



Intelligent/Addressable Devices

## General

Intelligent FlashScan® and CLIP mounting bases and kits provide a variety of ways to install NOTIFIER detectors in any application. Intelligent detectors can be mounted in either flanged or flangeless bases depending on junction box selection (see *Junction Box Selection Guide*). Across this product line, detectors plug in easily to the base with SEMS screws; and models employ various 12 to 24 AWG wire ranges.

**Relay, isolator, and sounder bases** can be used to meet local code requirements. Relay bases provide one Form-C contact relay for control of auxiliary functions such as door closure and elevator recall. Isolator bases allow loops to continue to operate under fault conditions and automatically restore when the fault is removed. Sounder bases are available in temporal and non-temporal pattern versions depending on whether the signal is to be used for evacuation purposes.

## Specifications

### Diameter:

- B501: 4.1" (104 mm).
- B224BI, B224RB, B210LP: 6.1" (155 mm).
- B200S/SR/SCOA: 6.875" (17.46 cm).

### Wire gauge:

- B224BI, B224RB: 14 to 24 AWG.
- B210LP, B501, B200S/SR/SCOA: 12 to 24 AWG.

### Temperature range:

- B224BI, B224RB, B200S/SR/SCOA: 32°F to 120°F (0°C to 49°C).
- B210LP, B501: -4°F to 150°F (-20°C to 66°C).

### Humidity range:

**System temperature and humidity ranges:** This system meets NFPA requirements for operation at 0°C to 49°C (32°F to 120°F); and at a relative humidity (noncondensing) of 85% at 30°C (86°F) per NFPA, and 93% ± 2% at 32°C ± 2°C (89.6°F ± 1.1°F) per ULC. However, the useful life of the system's standby batteries and the electronic components may be adversely affected by extreme temperature ranges and humidity. Therefore, it is recommended that this system and all peripherals be installed in an environment with a nominal room temperature of 15°C to 27°C (60°F to 80°F).

## Electrical Ratings

### FOR B200S/SR/SCOA:

**External supply voltage:** 16 to 33 VDC (VFWR)

**Standby current:** 500 µA maximum.

### Alarm current:

- B200S: 35 mA maximum at high-volume setting; 15 mA maximum at low-volume setting.
- B200SR: 35 mA maximum.
- B200SCOA: 40mA Max. (DC), 70mA Max. (FWR)

**SLC operating voltage:** 15 to 32 VDC.

**SLC standby current:** 300 µA.

### Sound output:



Flangeless Mounting Base  
B501(A)



Flanged Mounting Base  
B210LP(A)



Sounder Base  
B200S(A), B200SR(A),  
B200SCOA



Relay Base  
B224RB(A)

- B200S, high-volume\*: Greater than 85 dBA minimum.
- B200S, low-volume\*: Greater than 75 dBA minimum.
- B200SR\*: Greater than 85 dBA minimum.
- B200SCOA, high-volume\*\*: Greater than 87 dBA minimum.
- B200SCOA, low-volume\*\*: Greater than 85 dBA minimum

\*Measured in a UL reverberant room at 10 feet, 24 Volts (continuous tone)

\*\*Measured in a ULC anechoic room at 10 feet, 24 Volts continuous tone)

### FOR B224RB, B224BI:

**Operating voltage:** 15 to 32 VDC (powered by SLC).

**Standby ratings:** <500 µA maximum @ 24 VDC.

**Set time (B224RB only):** short delay 55 to 90 msec; long delay 6 to 9 seconds.

**Reset time (B224RB only):** 20 msec maximum.

**Relay characteristics (B224RB only):** two-coil latching relay; one Form-C contact; ratings (UL/CSA): 0.9 A @ 125 VAC, 0.9 A @ 110 VDC, and 3.0 A @ 30 VDC.

## Product Line Information

### INTELLIGENT BASES

**B501:** Flangeless mounting base.

**B501A:** Flangeless mounting base, ULC Listed.

**B501BP:** Bulk pack of B501 (10).

**B210LP:** Flanged mounting base.

**B210LPA:** Flanged mounting base, ULC listed

**B210LPBP:** Bulk pack of B210LP (10).

**B200S:** Intelligent addressable sounder base capable of producing sound output in high or low volume with ANSI Temporal 3, ANSI Temporal 4, continuous tone, marching tone, and custom tone. Uses FlashScan protocol. Only compatible with the NFS-320, NFS2-640 and NFS2-3030 operating version with version 15.0 or higher panel firmware.

**B200SA:** Same as B200S with ULC-listing.



**B200SCOA:** Same as B200S with ULC-listing and CO detector markings in English/French (required in Canada for ULC applications with FCO-851A).

**B200SR:** Intelligent sounder base capable of producing sound output with ANSI Temporal 3 or continuous tone.

**B200SRA:** Same as B200SR with ULC-listing.

**B224RB:** Relay base.

**B224RBA:** Relay base, ULC Listed.

**B224BI:** Isolator base.

**B224BIA:** Isolator base, ULC Listed.

### MOUNTING KITS AND ACCESSORIES

**SMB600:** Surface mounting kit, flanged.

**F110:** Retrofit flange for converting high-profile bases to low-profile.

**F110BP:** Bulk pack of F110 (10).

**F210:** Accessory flange ring for B210LP(A) base (new design). 6-inch diameter.

**F210BP:** Bulk pack of F210 (10).

**RA100Z:** Remote LED annunciator.

**RA100ZA:** Remote LED annunciator, ULC Listed.

**M02-04-00:** Detector test magnet.

**M02-09-00:** Test magnet with telescoping handle.

**XR2B:** Detector removal tool for current heads (T55-127-010 included).

**XR2:** Detector Remove Tool for use with low profile detector heads, and FSL-751.

**XP-4:** Extension pole for XR2/B (5 to 15 ft/1.524 to 4.572 m).

**T55-127-010:** Detector removal head.

**BCK-200B:** Black detector kit, package of 10 (for use with photo and ion detectors).

**WCK-200B:** White detector kit, package of 10 (for use with photo and ion detectors).

### Agency Listings and Approvals

The listings and approvals below apply to intelligent bases as noted. In some cases, certain modules or applications may not be listed by certain approval agencies, or listing may be in process. Consult factory for latest listing status.

- **UL Listed:** S911
- **ULC Listed:** S911
- **FM Approved**
- **MEA:** 22-95-E, 205-94-E Vol. 2; 257-06-E
- **CSFM:** 7300-1653:0126, 7135-1653:0213, 7300-1653:0109

### Junction Box Selection Guide

Base Models	Single Gang	3.5" Oct.	4.0" Oct.	4.0" Sq.	4.0" Sq. with 3.0" mud ring	50 mm	60 mm	70 mm	75 mm
B200S, B200SR, B200SCOA	Yes	Yes	Yes	Yes	Yes	No	No	No	No
B501	No	Yes	No	No	Yes	Yes	Yes	Yes	No
B210LP	Yes	Yes	Yes	Yes	Yes	No	No	No	No
B224RB	No	Yes	Yes	Yes	No	No	Yes	Yes	Yes
B224BI	No	Yes	Yes	Yes	No	No	No	Yes	Yes

**NOTE:** Box depth contingent on base and wire size. Refer to National Electric Code or applicable local codes for appropriate recommendations.

FlashScan®, NOTIFIER® and System Sensor® are registered trademarks of Honeywell International Inc. ©2013 by Honeywell International Inc. All rights reserved. Unauthorized use of this document is strictly prohibited.



This document is not intended to be used for installation purposes. We try to keep our product information up-to-date and accurate. We cannot cover all specific applications or anticipate all requirements. All specifications are subject to change without notice.



For more information, contact Notifier. Phone: (203) 484-7161, FAX: (203) 484-7118. [www.notifier.com](http://www.notifier.com)

# CO1224T/CO1224A

## Conventional Carbon Monoxide Detector



Conventional Initiating Devices

### General

Carbon monoxide (CO) is an odorless, colorless, tasteless and highly toxic gas that is produced when fuels, such as wood, gasoline, charcoal and oil, are burned with insufficient air. The majority of residential and commercial fatalities caused from these fuels come from heating systems, power tools and charcoal grills.

If carbon monoxide is detected, the **CO1224T/CO1224A** will alert by sounding and flashing a temp-4 signal alarm. Protection is guaranteed 24/7 by a central station if connected to a panel with a digital alarm communicator.

The CO1224T/CO1224A is specifically designed for system operation. This means the detector is fully listed to UL Standard 2075, offering a code required trouble relay, which sends a sensor failure or end-of-life signal to the control panel and the central station, as well as SEMS-type terminal Phillips-head screws, which provide a quicker and more positive wiring connection and code required wiring supervision. Also, the offers low current draw, allowing more detectors to be connected to the panel without having to purchase a more expensive panel or an extra power supply.

Add addressability to the by supervising the circuit with a compatible monitor module such as the FMM-101(A).

Special to the CO1224T is RealTest™ technology that allows testing of its internal CO detector with a carbon monoxide gas agent. There are few steps: Hold the test button for two seconds, and after the green LED begins to flash about once per second, spray a small amount of CO into the detector. The detector will alarm to indicate presence of gas.

**NOTE:** RealTest™ is only available on the UL-listed CO1224T. Refer to the installation documents for details and cautions.

### Features

- In the CO1224T, RealTest™ technology allows installer to test detector with CO gas.
- Full compliance with UL 2075.
- A code required trouble relay.
- Wiring supervision with SEMS terminals.
- A six-year end-of-life timer.
- 12/24 VDC.
- A current draw of 20mA in standby and 40mA in alarm.
- Versatile mounting for wall and ceiling.
- Electrochemical sensing technology.

### Specifications

#### ARCHITECTS'/ENGINEERS' SPECIFICATIONS

Carbon monoxide detector shall be a System Sensor model number , listed to UL 2075 for Gas and Vapor Detectors and Sensors. The detector shall be equipped with a sounder and a trouble relay. The detector's base shall be able to mount to a single-gang electrical box or direct (surface) mount to the wall or ceiling. Wiring connections shall be made by means of SEMS screws. The detector shall provide dual color LED indication, which blinks to indicate normal standby, alarm, or end-of-life. When the sensor supervision is in a trouble condition, the detector shall send a trouble signal to the panel. When the



detector gives a trouble or end-of-life signal, the detector shall be replaced.

#### ELECTRICAL SPECIFICATIONS

**Operating Voltage:** 12/24 VDC

**Audible Signal:** 85 dB in alarm

**Standby Current:** 20 mA

**Alarm Current:** 40 mA (75 mA test)

**Alarm Contact Ratings:** 0.5 A @ 30 VDC

**Trouble Contact Ratings:** 0.5 A @ 30 VDC

#### PHYSICAL SPECIFICATIONS

**Size:** 5.1"L x 3.3"W x 1.3"H

**Approximate Weight:** 7 oz

**Operating Temperature Range:** 0°C to 40°C (32°F to 104°F)

**Operating Humidity Range:** 22% to 90% RH

**Input Terminals:** 14 to 22 AWG

**Mounting:** Single-gang backbox; surface mount to wall or ceiling.

## Operation Modes

Operation Mode	Green LED	Red LED	Sounder
Normal (Standby)	Blink 1 per minute	–	–
Alarm	–	Blink in Temporal 4 pattern	Sound in Temporal 4 pattern
RealTest™ (CO1224T only)	Blink 1 per second	–	–

**Hush Feature:** Pushing the Test/Hush button will silence the sounder for 5 minutes (except in RealTest mode).

**Trouble Feature:** When the detector is in a trouble condition, it will send a trouble signal to the panel via the trouble contact.

**End-of-Life Timer:** After the sensor inside the detector has reached the end of its useful life, a trouble signal will be sent to the panel. This will indicate that it is time to replace the detector. An electrochemical carbon monoxide detector life span is approximately six years, and the detector must be replaced by the date marked on the inside of the product.

### MONITOR MODULE APPLICATIONS

When used in conjunction with the CO1224T or CO1224A, the monitor module should be programmed as a supervisory device type and is not suitable for evacuation purposes. Wire the module as an NFPA Style B (Class B) Initiating Device Circuit and terminate the with a 47K ohm End-of-line resistor (provided).

## Listings and Approvals

The listings and approvals below apply to the CO1224T and CO1224A. In some cases, certain modules may not be listed by certain approval agencies, or listing may be in process. Consult factory for latest listing status.

- **UL Listed:** E307195 (CO1224T)
- **ULC Listed:** E304075 (CO1224A)

## Product Line Information

**CO1224T:** 12/24 volt, 4-wire system-monitored carbon monoxide detector with RealTest™ Technology. Replaces CO1224.

**CO1224A:** 12/24 volt, 4-wire system-monitored carbon monoxide detector, ULC-listed for use in Canadian applications.

**CO-PLATE:** CO detector replacement plate, package of 5. Covers previously installed round detectors' footprints for a clean, low-profile finish.

Notifier® is a registered trademark and RealTest™ is a trademark of Honeywell International Inc.  
©2010 by Honeywell International Inc. All rights reserved. Unauthorized use of this document is strictly prohibited.



This document is not intended to be used for installation purposes.  
We try to keep our product information up-to-date and accurate.  
We cannot cover all specific applications or anticipate all requirements.  
All specifications are subject to change without notice.



Made in the U.S. A.

For more information, contact Notifier. Phone: (203) 484-7161, FAX: (203) 484-7118.  
[www.notifier.com](http://www.notifier.com)

# DNR(A)/DNRW InnovairFlex

## Intelligent Non-Relay Photoelectric Duct Smoke Detector



Intelligent Devices

### General

The Notifier InnovairFlex® DNR(A) intelligent non-relay photoelectric duct smoke detector and DNRW watertight non-relay photoelectric duct smoke detector feature a pivoting housing that fits both square and rectangular footprints capable of mounting to a round or rectangular duct.

DNRW duct smoke detector, with its NEMA-4 rating, is listed as a watertight, UV resistant enclosure providing protection against falling dirt, rain, and windblown dust, splashing and hose directed water, allowing operators to use the detector in the most extreme environments.

These units sense smoke in the most challenging conditions, operating in airflow speeds of 100 to 4,000 feet per minute (0.5 to 20.32 m/s), temperatures of -4°F to 158°F (-20°C to 70°C), and a humidity range of 0 to 95 percent (non-condensing.)

An improved cover design isolates the sensor head, which allows for ease of maintenance. A cover tamper feature indicates a trouble signal for a removed or improperly installed sensor cover. The Notifier InnovairFlex housing provides a 3/4-inch conduit knockout and ample space to facilitate easy wiring and mounting of a relay module.

The Notifier InnovairFlex duct smoke detector can be customized to meet local codes and specifications without additional wiring. The new InnovairFlex product line is compatible with all previous Innovair models, including remote test accessories.

### Features

- Photoelectric, integrated low-flow technology.
- Air velocity rating from 100 ft/min to 4,000 ft/min (0.5 m/s to 20.32 m/s).
- Versatile mounting options: square or rectangular configuration.
- Broad ranges for operating temperature (-4°F to 158°F, -20°C to 70°C) and humidity (0% to 95% non-condensing).
- Patented sampling tube installs from front or back of the detector with no tools required.
- Cover tamper signal.
- Increased wiring space with a newly added 3/4" conduit knockout.
- Available space within housing to accommodate mounting of a relay module.
- Easily accessible code wheels on sensor head (sold separately).
- Clear cover for convenient visual inspection.
- Remote testing capability.
- Requires com line power only.
- Accommodates the installation of an addressable relay module, sold separately, (FRM-1 or NC-100R) for applications requiring a Form-C relay.

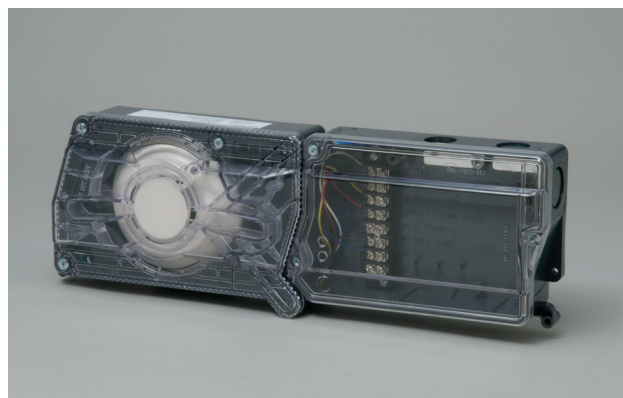

### Specifications

**Size: (Rectangle)** 14.38 in (37 cm) Length; 5 in (12.7 cm) Width, 2.5 in (6.6 cm) Depth.

**Size: (Square)** 7.75 in (19.7 cm) Length; 9 in (22.9 cm) Width; 2.5 in (6.35 cm) Depth.

**Weight:** 1.6 lb (0.73 kg).

**Operating Temperature Range:** -4°F to 158°F (-20°C to 70°C).

**Storage Temperature Range:** -22°F to 158°F (-30°C to 70°C).

**Operating Humidity Range:** 0% to 95% relative humidity (non-condensing).

**Air Duct Velocity:** 100 to 4,000 ft/min (0.5 to 20.32 m/s).

### Accessories

Notifier provides system flexibility with a variety of accessories, including two remote test stations and different means of visible and audible system annunciation. As with our duct smoke detectors, all duct smoke detectors accessories are UL listed.

DNR(W)s with a date code of 0013 or higher do not require external 24VDC for remote test applications when used with a remote-test-capable detector.

### ACCESSORY CURRENT LOADS AT 24 VDC

Device	Standby	Alarm
RA100Z	0mA	12 mA Max
RTS151/ RTS151KEY	0mA	12mA Max

### Agency Listings and Approvals

Consult product manual for lists of compatible UL-Listed devices. In some cases, certain modules may not be listed by certain approval agencies, or listing may be in process. Consult factory for latest listing status.

- **UL:** S911, S3705.
- **ULC:** S635.

- **CSFM:** 3242-1653:0209.
- **FM approved.**

## Product Line Information

**NOTE:** "A suffix indicates ULC listed model.

**DNR(A):** Intelligent non-relay photoelectric low flow smoke detector housing. Requires photoelectric smoke detector (sold separately).

**DNRW:** Watertight intelligent non-relay photoelectric low flow duct smoke detector housing. Requires photoelectric smoke detector (sold separately).

**FSP-851R(A):** Remote test capable addressable low-profile photoelectric smoke detector.

**FSP-851(A):** Addressable low-profile photoelectric smoke detector.

**NP-100:** Addressable low-profile photoelectric smoke detector for FireWarden series panels.

**NP-100R(A):** Remote test capable addressable low-profile photoelectric smoke detector for FireWarden series panels.

**DCOIL:** Remote test coil. Required for older DNR(W) duct detector housing.

**DST1(A):** Metal sampling tube duct width up to 1 ft (0.3m).

**DST1.5(A):** Metal sampling tube duct widths up to 1 ft to 2 ft (0.3 to 0.6 m).

**DST3(A):** Metal sampling tube duct widths up to 2 ft to 4 ft (0.6 to 1.2 m).

**DST5(A):** Metal sampling tube duct widths up to 4 ft to 8 ft (1.2 to 2.4 m).

**DST10(A):** Metal sampling tube duct widths up to 8 ft to 12 ft (2.4 to 3.7 m).

**DH400OE-1:** Weatherproof enclosure.

**ETX:** Metal exhaust tube duct, width 1 ft (0.3 m).

**M02-04-00:** Test magnet.

**P48-21-00:** End cap for metal sampling tubes.

**RA100Z(A):** Remote annunciator alarm LED.

**RTS151(A):** Remote test station.

**RTS151KEY(A):** Remote test station with key lock.

## Important Note

- DNRW duct detector housings with a date code of 0013 or higher do not require a DCOIL or auxiliary 24 VDC for remote test applications when used with a remote test capable detector.
- DNRW duct detector housings with a date code of 0012 or earlier require a DCOIL and auxiliary 24 VDC power for remote test applications.

Notifier® and FlashScan® are a registered trademark of Honeywell International Inc.

©2012 by Honeywell International Inc. All rights reserved. Unauthorized use of this document is strictly prohibited.



This document is not intended to be used for installation purposes.  
We try to keep our product information up-to-date and accurate.  
We cannot cover all specific applications or anticipate all requirements.  
All specifications are subject to change without notice.



For more information, contact Notifier. Phone: (203) 484-7161, FAX: (203) 484-7118.  
[www.notifier.com](http://www.notifier.com)

# Duct Smoke Detector Accessories

## for Notifier/System Sensor Products



Miscellaneous

### General

Duct smoke detector accessories add functionality to the duct smoke system by allowing quick, convenient inspections at eye level and effective audible and visual notification options. All System Sensor duct smoke detectors and accessories are UL listed.

### Specifications

#### APA151 PIEZO ANNUNCIATOR

The **APA151** piezo annunciator, which replaces the APA451 with a new, improved look, provides an audible alarm signal, a red LED to indicate alarm status, and a green LED to indicate power status. It is intended for use with System Sensor 4-wire conventional duct smoke detector applications without a system control panel, to comply with NFPA 90A.



APA151.wmf

APA151 Piezo Annunciator	
Voltage	Regulated 24 VDC
Operating Voltage	16 to 33 VDC
Maximum Alarm Current	30 mA
Temperature Range	32°F to 120°F (0°C to 49°C)
Relative Humidity	10 to 93%, non-condensing
Wire Gauge	12 to 18 AWG
Dimensions	4.6" H x 2.9" W x .45" D

#### MHR/MHW MINI-HORNS

The **MHR** and **MHW** SpectrAlert® Advance mini-horns feature temporal or continuous tones at high and low volume settings. Their small footprint allows mounting to single-gang back boxes for applications where a small device is desired.



MHR.wmf, MHW.wmf



60535cov.wmf

MHR/MHW SpectrAlert Advance Mini-Horns	
Voltage	Regulated 12 DC or FWR (Full Wave Rectified) or Regulated 24 VDC or FWR
Operating Voltage	8 to 33 VDC (9 to 33 VDC with Sync-Circuit™ Module)
Sounder Current Draw	22 mA RMS max. at 8 to 17.5 Volts DC 17 mA RMS max. at 8 to 17.5 Volts FWR 29 mA RMS max. at 16 to 33 Volts DC 25 mA RMS max. at 16 to 33 Volts FWR
Temperature Range	32°F to 120°F (0°C to 49°C)
Humidity Range	10 to 93% non-condensing
Nominal Sounder Frequency	3 kHz
Wire Gauge	12 to 18 AWG
Dimensions	4.6"H x 2.9"W x 0.45"D

### RA100Z/RA100ZA REMOTE ANNUNCIATORS

The **RA100Z** and **RA100ZA** remote annunciators are designed for both conventional and intelligent applications. Their red LED provides visual indication of an alarm condition.



RA100Z.wmf

RA100Z/RA100ZA Remote Annunciator	
Voltage Range	Conventional System: 3.1 to 32 VDC Intelligent System: 18 to 32 VDC
Maximum Alarm Current	10 mA
Dimensions	4.6"H x 2.8"W x 1.3"D

### RTS151/RTS151KEY REMOTE TEST STATIONS

The **RTS151** and **RTS151KEY** remote test stations are automatic fire detector accessories designed to test duct smoke detectors from a convenient location. For 4-wire detectors, the **RTS151KEY** test station features a multi-colored LED that alternates between steady green and red. For 2-wire detectors, the LED illuminates red for alarm.



RTS151.wmf, RTS151KEY.wmf

RTS151 Remote Test Station	
Power Requirements	Alarm LED 2.8 to 32 VDC, 10 mA max. Total Current: 95 mA max.
Test Switch	10 VA @ 32 VDC
Reset Switch	10 VA @ 32 VDC
Alarm Response Time	40 seconds max.
Temperature Range	14°F to 140°F (-10°C to 60°C)
Relative Humidity	95% non-condensing
Wire Gauge	14 to 18 AWG
Dimensions	4.8"H x 2.9W x 1.4"D

### RTS151KEY Remote Test Station with Key

Power Requirements	Power LED (Green): 14 to 35 VDC, 12 mA max. Alarm LED (RED): 2.8 to 32 VDC, 12 mA max.
Alarm Response Time	40 seconds max.
Temperature Range	14°F to 140°F (-10°C to 60°C)
Relative Humidity	95% non-condensing
Wire Gauge	14 to 18 AWG
Dimensions	4.6"H x 2.75W x 1.8"D

### RTS2/RTS-AOS MULTI-SIGNALLING ACCESSORIES

The **RTS2** and **RTS2-AOS** multi-signaling accessories are designed to work with InnovairFlex 4-wire conventional duct smoke detectors. These accessories include a key switch that can be used to select one of two connected sensors to be tested, reset, or both by a push button switch. They also enable sensitivity measurements using the SENS-RDR sensitivity reader (sold separately). The **AOS** (Add-On Strobe) is an optional accessory included with the **RTS2-AOS** model.



RTS-AOS.wmf, AOS.wmf

### RTS2 and RTS-AOS Multi-Signaling Accessory

Voltage	20 to 29 VDC
Power Requirements	Standby: 3.0 mA max. Trouble: 16.0 mA max. Alarm without Strobe: 30 mA max. Alarm with Strobe: 55 mA max.
Sounder	85 dBA at 10 ft.
Temperature Range	14°F to 140°F (-10°C to 60°C)
Relative Humidity	95% non-condensing
Wire Gauge	14 to 22 AWG
Dimensions	4.8"W x 5.3"H x 1.6"D

## Product Line Information

**APA151:** Piezo Annunciator

**MHR:** Mini-Horn, Red

**MHW:** Mini-Horn, White

**RA100Z/RA100ZA:** Remote Annunciator

**RTS151:** Remote Test Station

**RTS151KEY:** Remote Test Station with Key

**RTS2:** Multi-signaling Accessory

**AOS:** Add-On Strobe

**RTS2-AOS:** Multi-Signaling Accessory

## Temperature and Humidity Ranges

This system meets NFPA requirements for operation at 0 – 49°C/32 – 120°F and at a relative humidity 93% ± 2% RH (noncondensing) at 32°C ± 2°C (90°F ± 3°F). However, the useful life of the system's standby batteries and the electronic components may be adversely affected by extreme temperature ranges and humidity. Therefore, it is recommended that this system and its peripherals be installed in an environment with a normal room temperature of 15 – 27°C/60 – 80°F.

## Agency Listings and Approvals

The listings and approvals below apply to the basic products. In some cases, certain modules may not be listed by certain approval agencies, or listing may be in process. Consult factory for latest listing status.

- **UL: S4011 (APA 151, MHR, MHW), S2522 (RTS2, RA100Z, RTS151, RTS151KEY, RTS2-AOS)**
- **FM Approved**
- **CSFM: 7135-1653:0212**



---

**FlashScan®**, **NOTIFIER®** and **System Sensor®** are registered trademarks of Honeywell International Inc.  
©2012 by Honeywell International Inc. All rights reserved. Unauthorized use of this document is strictly prohibited.

---



This document is not intended to be used for installation purposes.  
We try to keep our product information up-to-date and accurate.  
We cannot cover all specific applications or anticipate all requirements.  
All specifications are subject to change without notice.



Made in the U.S. A.

For more information, contact Notifier. Phone: (203) 484-7161, FAX: (203) 484-7118.  
[www.notifier.com](http://www.notifier.com)

# NBG-12LX

## Addressable Manual Pull Station



Intelligent/Addressable Devices

### General

The Notifier NBG-12LX is a state-of-the-art, dual-action (i.e., requires two motions to activate the station) pull station that includes an addressable interface for any Notifier intelligent control panel except FireWarden series panels, and the NSP-25 panel. Because the NBG-12LX is addressable, the control panel can display the exact location of the activated manual station. This leads fire personnel quickly to the location of the alarm.

### Features

- Maintenance personnel can open station for inspection and address setting without causing an alarm condition.
- Built-in bicolor LED, which is visible through the handle of the station, flashes in normal operation and latches steady red when in alarm.
- Handle latches in down position and the word “ACTIVATED” appears to clearly indicate the station has been operated.
- Captive screw terminals wire-ready for easy connection to SLC loop (accepts up to 12 AWG/3.25 mm<sup>2</sup> wire).
- Can be surface mounted (with SB-10 or SB-I/O) or semi-flush mounted. Semi-flush mount to a standard single-gang, double-gang, or 4" (10.16 cm) square electrical box.
- Smooth dual-action design.
- Meets ADAAG controls and operating mechanisms guidelines (Section 4.1.3[13]); meets ADA requirement for 5 lb. maximum activation force.
- Highly visible.
- Attractive shape and textured finish.
- Key reset.
- Includes Braille text on station handle.
- Optional trim ring (BG12TR).
- Meets UL 38, Standard for Manually Actuated Signaling Boxes.
- Up to 99 NBG-12LX stations per loop on CLIP protocol loops.
- Up to 159 NBG-12LX stations per loop on FlashScan® protocol loops.
- Dual-color LED blinks green to indicate normal on FlashScan® systems.

### Construction

Shell, door, and handle are molded of durable polycarbonate material with a textured finish.

### Specifications

- **Shipping Weight:** 9.6 oz. (272.15 g)
- **Normal operating voltage:** 24 VDC.
- **Maximum SLC loop voltage:** 28.0 VDC.
- **Maximum SLC standby current:** 375 µA.
- **Maximum SLC alarm current:** 5 mA.
- **Temperature Range:** 32°F to 120°F (0°C to 49°C)
- **Relative Humidity:** 10% to 93% (noncondensing)
- **For use indoors in a dry location**



The NBG-12LX  
Addressable Manual Pull Station

### Installation

The NBG-12LX will mount semi-flush into a single-gang, double-gang, or standard 4" (10.16 cm) square electrical outlet box, or will surface mount to the model SB-10 or SB-I/O surface backbox. If the NBG-12LX is being semi-flush mounted, then the optional trim ring (BG12TR) may be used. The BG12TR is usually needed for semi-flush mounting with 4" (10.16 cm) or double-gang boxes (not with single-gang boxes).

### Operation

Pushing in, then pulling down on the handle causes it to latch in the down/activated position. Once latched, the word “ACTIVATED” (in bright yellow) appears at the top of the handle, while a portion of the handle protrudes from the bottom of the station. To reset the station, simply unlock the station with the key and pull the door open. This action resets the handle; closing the door automatically resets the switch.

Each manual station, on command from the control panel, sends data to the panel representing the state of the manual switch. Two rotary decimal switches allow address settings (1 – 159 on FlashScan® systems, 1 – 99 on CLIP systems).

### Architectural/Engineering Specifications

Manual Fire Alarm Stations shall be non-coded, with a key-operated reset lock in order that they may be tested, and so designed that after actual Emergency Operation, they cannot be restored to normal except by use of a key. An operated station shall automatically condition itself so as to be visually detected as activated. Manual stations shall be constructed of red-colored polycarbonate material with clearly visible operating instructions provided on the cover. The word FIRE shall appear on the front of the stations in white letters, 1.00 inches (2.54 cm) or larger. Stations shall be suitable for surface mounting on matching backbox SB-10 or SB-I/O; or semi-flush mounting on a standard single-gang, double-gang, or

4" (10.16 cm) square electrical box, and shall be installed within the limits defined by the Americans with Disabilities Act (ADA) or per national/local requirements. Manual Stations shall be Underwriters Laboratories listed.

Manual stations shall connect with two wires to one of the control panel SLC loops. The manual station shall, on command from the control panel, send data to the panel representing the state of the manual switch. Manual stations shall provide address setting by use of rotary decimal switches.

The loop poll LED shall be clearly visible through the front of the station. The LED shall flash while in the normal condition, and stay steadily illuminated when in alarm.

## Product Line Information

**NBG-12LX:** Dual-action addressable pull station. Includes key locking feature. (Listed for Canadian and non-Canadian applications.)

**NBG-12LXSP:** Spanish/English labelled version.

**NBG-12LXP:** Portuguese labelled version.

**SB-10:** Surface backbox; metal.

**SB-I/O:** Surface backbox; plastic.

**BG12TR:** Optional trim ring.

**17021:** Keys, set of two.

**NY-Plate:** New York City trim plate.

## Agency Listings and Approvals

In some cases, certain modules or applications may not be listed by certain approval agencies, or listing may be in process. Consult factory for latest listing status.

- **UL/ULC Listed:** S692 (listed for Canadian and non-Canadian applications).
- **MEA:** 67-02-E.
- **CSFM:** 7150-0028:0199.
- **FDNY:** COA #6085 (NFS2-640), COA #6098 (NFS2-3030).
- **BSMI:** CI313066760047.
- **U.S. Coast Guard.**
- **Lloyd's Register.**
- **FM Approved.**

**Patented:** U.S. Patent No. D428,351; 6,380,846; 6,314,772; 6,632,108.

NOTIFIER® and FlashScan® are registered trademarks of Honeywell International Inc.

©2012 by Honeywell International Inc. All rights reserved. Unauthorized use of this document is strictly prohibited.



This document is not intended to be used for installation purposes.  
We try to keep our product information up-to-date and accurate.  
We cannot cover all specific applications or anticipate all requirements.  
All specifications are subject to change without notice.



Made in the U.S. A.

For more information, contact Notifier. Phone: (203) 484-7161, FAX: (203) 484-7118.  
[www.notifier.com](http://www.notifier.com)

# FMM-1(A), FMM-101(A), FZM-1(A) & FDM-1(A)

## Monitor Modules with FlashScan®



Intelligent/Addressable Devices

### General

Four different monitor modules are available for Notifier's intelligent control panels for a variety of applications. Monitor modules supervise a circuit of dry-contact input devices, such as conventional heat detectors and pull stations, or monitor and power a circuit of two-wire smoke detectors (FZM-1(A)).

**FMM-1(A)** is a standard-sized module (typically mounts to a 4" [10.16 cm] square box) that supervises either a Style D (Class A) or Style B (Class B) circuit of dry-contact input devices.

**FMM-101(A)** is a miniature monitor module a mere 1.3" (3.302 cm) H x 2.75" (6.985 cm) W x 0.5" (1.270 cm) D that supervises a Style B (Class B) circuit of dry-contact input devices. Its compact design allows the FMM-101(A) to be mounted in a single-gang box behind the device it monitors.

**FZM-1(A)** is a standard-sized module that monitors and supervises compatible two-wire, 24 volt, smoke detectors on a Style D (Class A) or Style B (Class B) circuit.

**FDM-1(A)** is a standard-sized dual monitor module that monitors and supervises two independent two-wire Style B (Class B) dry-contact initiating device circuits (IDCs) at two separate, consecutive addresses in intelligent, two-wire systems.

FlashScan® (U.S. Patent 5,539,389) is a communication protocol developed by NOTIFIER that greatly increases the speed of communication between analog intelligent devices. Intelligent devices communicate in a grouped fashion. If one of the devices within the group has new information, the panel CPU stops the group poll and concentrates on single points. The net effect is response speed greater than five times that of other designs.

### FMM-1(A) Monitor Module

- Built-in type identification automatically identifies this device as a monitor module to the control panel.
- Powered directly by two-wire SLC loop. No additional power required.
- High noise (EMF/RFI) immunity.
- SEMS screws with clamping plates for ease of wiring.
- Direct-dial entry of address: 01 – 159 on FlashScan loops; 01 – 99 on CLIP loops.
- LED flashes green during normal operation (this is a programmable option) and latches on steady red to indicate alarm.

The FMM-1(A) Monitor Module is intended for use in intelligent, two-wire systems, where the individual address of each module is selected using the built-in rotary switches. It provides either a two-wire or four-wire fault-tolerant Initiating Device Circuit (IDC) for normally-open-contact fire alarm and supervisory devices. The module has a panel-controlled LED indicator. The FMM-1(A) can be used to replace MMX-1(A) modules in existing systems.

### FMM-1(A) APPLICATIONS

Use to monitor a zone of four-wire smoke detectors, manual fire alarm pull stations, waterflow devices, or other normally-open dry-contact alarm activation devices. May also be used to monitor normally-open supervisory devices with special supervisory indication at the control panel. Monitored circuit may be wired as an NFPA Style B (Class B) or Style D (Class

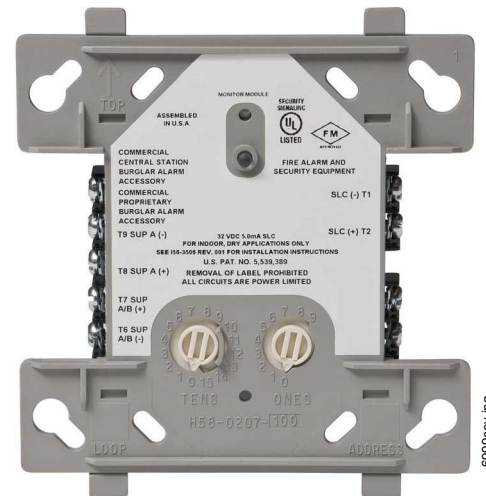

FMM-1(A) (Type H)

A) Initiating Device Circuit. A 47K ohm End-of-Line Resistor (provided) terminates the Style B circuit. No resistor is required for supervision of the Style D circuit.

### FMM-1(A) OPERATION

Each FMM-1(A) uses one of the available module addresses on an SLC loop. It responds to regular polls from the control panel and reports its type and the status (open/normal/short) of its Initiating Device Circuit (IDC). A flashing LED indicates that the module is in communication with the control panel. The LED latches steady on alarm (subject to current limitations on the loop).

### FMM-1(A) SPECIFICATIONS

**Nominal operating voltage:** 15 to 32 VDC.

**Maximum current draw:** 5.0 mA (LED on).

**Average operating current:** 350  $\mu$ A (LED flashing), 1 communication every 5 seconds, 47k EOL.

**Maximum IDC wiring resistance:** 40 ohms.

**EOL resistance:** 47K ohms.

**Temperature range:** 32°F to 120°F (0°C to 49°C).

**Humidity range:** 10% to 93% noncondensing.

**Dimensions:** 4.5" (11.43 cm) high x 4" (10.16 cm) wide x 1.25" (3.175 cm) deep. Mounts to a 4" (10.16 cm) square x 2.125" (5.398 cm) deep box.

## FMM-101(A) Mini Monitor Module

- Built-in type identification automatically identifies this device as a monitor module to the panel.
- Powered directly by two-wire SLC loop. No additional power required.
- High noise (EMF/RFI) immunity.
- Tinned, stripped leads for ease of wiring.
- Direct-dial entry of address: 01 – 159 on FlashScan loops; 01 – 99 on CLIP loops.

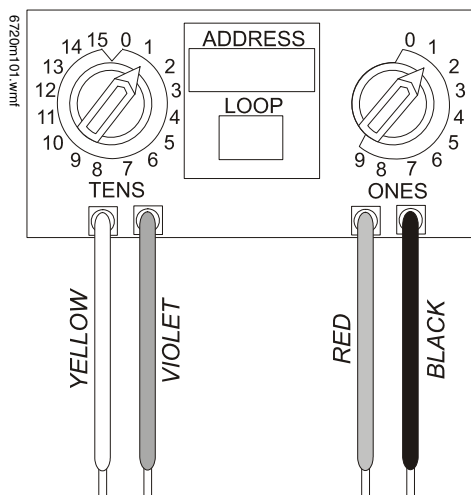

The FMM-101(A) Mini Monitor Module can be installed in a single-gang junction directly behind the monitored unit. Its small size and light weight allow it to be installed without rigid mounting. The FMM-101(A) is intended for use in intelligent, two-wire systems where the individual address of each module is selected using rotary switches. It provides a two-wire initiating device circuit for normally-open-contact fire alarm and security devices. The FMM-101(A) can be used to replace MMX-101(A) modules in existing systems.

### FMM-101(A) APPLICATIONS

Use to monitor a single device or a zone of four-wire smoke detectors, manual fire alarm pull stations, waterflow devices, or other normally-open dry-contact devices. May also be used to monitor normally-open supervisory devices with special supervisory indication at the control panel. Monitored circuit/device is wired as an NFPA Style B (Class B) Initiating Device Circuit. A 47K ohm End-of-Line Resistor (provided) terminates the circuit.

### FMM-101(A) OPERATION

Each FMM-101(A) uses one of the available module addresses on an SLC loop. It responds to regular polls from the control panel and reports its type and the status (open/normal/short) of its Initiating Device Circuit (IDC).

### FMM-101(A) SPECIFICATIONS

Nominal operating voltage: 15 to 32 VDC.

**Average operating current:** 350  $\mu$ A, 1 communication every 5 seconds, 47k EOL; 600  $\mu$ A Max. (Communicating, IDC Shorted).

**Maximum IDC wiring resistance:** 40 ohms.

**Maximum IDC Voltage:** 11 Volts.

**Maximum IDC Current:** 400  $\mu$ A.

**EOL resistance:** 47K ohms.

**Temperature range:** 32°F to 120°F (0°C to 49°C).

**Humidity range:** 10% to 93% noncondensing.

**Dimensions:** 1.3" (3.302 cm) high x 2.75" (6.985 cm) wide x 0.65" (1.651 cm) deep.

**Wire length:** 6" (15.24 cm) minimum.

## FZM-1(A) Interface Module

- Supports compatible two-wire smoke detectors.
- Supervises IDC wiring and connection of external power source.
- High noise (EMF/RFI) immunity.
- SEMS screws with clamping plates for ease of wiring.
- Direct-dial entry of address: 01 – 159 on FlashScan loops, 01 – 99 on CLIP loops.
- LED flashes during normal operation; this is a programmable option.
- LED latches steady to indicate alarm on command from control panel.

The FZM-1(A) Interface Module is intended for use in intelligent, addressable systems, where the individual address of each module is selected using built-in rotary switches. This module allows intelligent panels to interface and monitor two-wire conventional smoke detectors. It transmits the status (normal, open, or alarm) of one full zone of conventional detectors back to the control panel. All two-wire detectors being monitored must be UL compatible with the module. The FZM-1(A) can be used to replace MMX-2(A) modules in existing systems.

### FZM-1(A) APPLICATIONS

Use the FZM-1(A) to monitor a zone of two-wire smoke detectors. The monitored circuit may be wired as an NFPA Style B (Class B) or Style D (Class A) Initiating Device Circuit. A 3.9 K ohm End-of-Line Resistor (provided) terminates the end of the Style B or D (class B or A) circuit (maximum IDC loop resistance is 25 ohms). Install ELR across terminals 8 and 9 for Style D application.

### FZM-1(A) OPERATION

Each FZM-1(A) uses one of the available module addresses on an SLC loop. It responds to regular polls from the control panel and reports its type and the status (open/normal/short) of its Initiating Device Circuit (IDC). A flashing LED indicates that the module is in communication with the control panel. The LED latches steady on alarm (subject to current limitations on the loop).

### FZM-1(A) SPECIFICATIONS

**Nominal operating voltage:** 15 to 32 VDC.

**Maximum current draw:** 5.1 mA (LED on).

**Maximum IDC wiring resistance:** 25 ohms.

**Average operating current:** 300  $\mu$ A, 1 communication and 1 LED flash every 5 seconds, 3.9k eol.

**EOL resistance:** 3.9K ohms.

**External supply voltage (between Terminals T3 and T4):** DC voltage: 24 volts power limited. Ripple voltage: 0.1 Vrms maximum. Current: 90 mA per module maximum.

**Temperature range:** 32°F to 120°F (0°C to 49°C).

**Humidity range:** 10% to 93% noncondensing.

**Dimensions:** 4.5" (11.43 cm) high x 4" (10.16 cm) wide x 1.25" (3.175 cm) deep. Mounts to a 4" (10.16 cm) square x 2.125" (5.398 cm) deep box.

## FDM1(A) Dual Monitor Module

The FDM-1(A) Dual Monitor Module is intended for use in intelligent, two-wire systems. It provides two independent two-wire initiating device circuits (IDCs) at two separate, consecutive addresses. It is capable of monitoring normally open contact fire alarm and supervisory devices; or either normally open or normally closed security devices. The module has a single panel-controlled LED.

**NOTE:** The FDM-1(A) provides two Style B (Class B) IDC circuits ONLY. Style D (Class A) IDC circuits are NOT supported in any application.

### FDM-1(A) SPECIFICATIONS

**Normal operating voltage range:** 15 to 32 VDC.

**Maximum current draw:** 6.4 mA (LED on).

**Average operating current:** 750  $\mu$ A (LED flashing).

**Maximum IDC wiring resistance:** 1,500 ohms.

**Maximum IDC Voltage:** 11 Volts.

**Maximum IDC Current:** 240  $\mu$ A

**EOL resistance:** 47K ohms.

**Maximum SLC Wiring resistance:** 40 Ohms.

**Temperature range:** 32° to 120°F (0° to 49°C).

**Humidity range:** 10% to 93% (non-condensing).

**Dimensions:** 4.5" (11.43 cm) high x 4" (10.16 cm) wide x 2.125" (5.398 cm) deep.

### FDM-1(A) AUTOMATIC ADDRESSING

The FDM-1(A) automatically assigns itself to two addressable points, starting with the original address. For example, if the FDM-1(A) is set to address "26", then it will automatically assign itself to addresses "26" and "27".

**NOTE:** "Ones" addresses on the FDM-1(A) are 0, 2, 4, 6, or 8 only. Terminals 6 and 7 use the first address, and terminals 8 and 9 use the second address.



#### CAUTION:

Avoid duplicating addresses on the system.

---

## Installation

FMM-1(A), FZM-1(A), and FDM-1(A) modules mount directly to a standard 4" (10.16 cm) square, 2.125" (5.398 cm) deep, electrical box. They may also be mounted to the SMB500 surface-mount box. Mounting hardware and installation instructions are provided with each module. All wiring must conform to applicable local codes, ordinances, and regulations. These modules are intended for power-limited wiring only.

The FMM-101(A) module is intended to be wired and mounted without rigid connections inside a standard electrical box. All wiring must conform to applicable local codes, ordinances, and regulations.

## Agency Listings and Approvals

In some cases, certain modules may not be listed by certain approval agencies, or listing may be in process. Consult factory for latest listing status.

- **UL:** S635
- **ULC:** S635
- **FM Approved**
- **CSFM:** 7300-0028:0219
- **MEA:** 457-99-E
- **U.S. Coast Guard:**

– 161.002/23/3 (AFP-200: FMM-1/-101, FZM-1)

– 161.002/42/1 (NFS-640: FMM-1/-101)

- **Lloyd's Register:**

– 03/60011/E1 (FMM-1/-101, FZM-1)

– 94/60004/E2 (AFP-200: *except* FDM-1)

– 02/60007 (NFS-640: FDM-1)

- **FDNY:** COA #6038 (NFS2-640, NFS-320), COA# 6058 (NFS2-3030)

## Product Line Information

**NOTE:** "A" suffix indicates ULC-listed model.

**FMM-1(A):** Monitor module.

**FMM-101(A):** Monitor module, miniature.

**FZM-1(A):** Monitor module, two-wire detectors.

**FDM-1(A):** Monitor module, dual, two independent Class B circuits.

**SMB500:** Optional surface-mount backbox.

**NOTE:** See installation instructions and refer to the SLC Wiring Manual, PN 51253.

---

FlashScan® and NOTIFIER® are registered trademarks and FireWatch™ is a trademark of Honeywell International Inc.  
©2010 by Honeywell International Inc. All rights reserved. Unauthorized use of this document is strictly prohibited.



This document is not intended to be used for installation purposes.  
We try to keep our product information up-to-date and accurate.  
We cannot cover all specific applications or anticipate all requirements.  
All specifications are subject to change without notice.

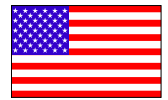

Made in the U.S. A.

For more information, contact Notifier. Phone: (203) 484-7161, FAX: (203) 484-7118.  
[www.notifier.com](http://www.notifier.com)

# FCM-1(A) & FRM-1(A) Series

## Control and Relay Modules



Intelligent / Addressable Devices

### General

**FCM-1(A) Control Module:** The FCM-1(A) Addressable Control Module provides Notifier intelligent fire alarm control panels a circuit for Notification Appliances (horns, strobes, speakers, etc.). Addressability allows the FCM-1(A) to be activated, either manually or through panel programming, on a select (zone or area of coverage) basis.

**FRM-1(A) Relay Module:** The FRM-1(A) Addressable Relay Module provides the system with a dry-contact output for activating a variety of auxiliary devices, such as fans, dampers, control equipment, etc. Addressability allows the dry contact to be activated, either manually or through panel programming, on a select basis.

FlashScan® (U.S. Patent 5,539,389) is a communication protocol developed by NOTIFIER Engineering that greatly enhances the speed of communication between analog intelligent devices. Intelligent devices communicate in a grouped fashion. If one of the devices within the group has new information, the panel CPU stops the group poll and concentrates on single points. The net effect is response speed greater than five times that of other designs.

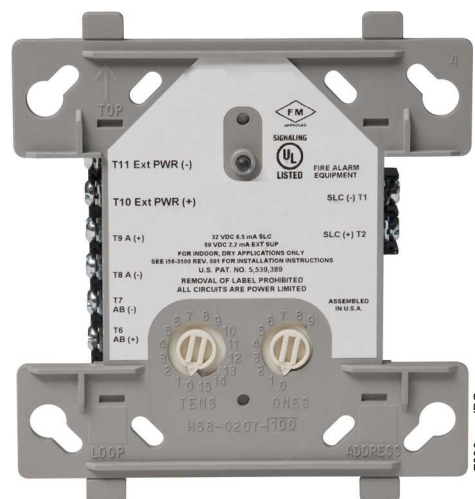

FCM-1(A)

### Features

- Built-in type identification automatically identifies these devices to the control panel.
- Internal circuitry and relay powered directly by two-wire SLC loop. The FCM-1(A) module requires power (for horns, strobes, etc.), or audio (for speakers).
- Integral LED “blinks” green each time a communication is received from the control panel and turns on in steady red when activated.
- LED blink may be deselected globally (affects all devices).
- High noise immunity (EMF/RFI).
- The FCM-1(A) may be used to switch 24-volt NAC power, audio (up to 70.7 Vrms).
- Wide viewing angle of LED.
- SEMS screws with clamping plates for wiring ease.
- Direct-dial entry of address 01– 159 for FlashScan loops, 01 – 99 for CLIP mode loops.
- Speaker, and audible/visual applications may be wired for Class B or A (Style Y or Z).

### Applications

The FCM-1(A) is used to switch 24 VDC audible/visual power, high-level audio (speakers). The FRM-1(A) may be programmed to operate dry contacts for applications such as door holders or Air Handling Unit shutdown, and to reset four-wire smoke detector power.

**NOTE:** Refer to the SLC Manual (PN 51253) for details regarding releasing applications with the FCM-1(A). Refer to the FCM-1-REL datasheet (DN-60390) for new FlashScan® releasing applications.

### Construction

- The face plate is made of off-white heat-resistant plastic.
- Controls include two rotary switches for direct-dial entry of address (01-159).

- The FCM-1(A) is configured for a single Class B (Style Y) or Class A (Style Z) Notification Appliance Circuit.
- The FRM-1(A) provides two Form-C dry contacts that switch together.

### Operation

Each FCM-1(A) or FRM-1(A) uses one of 159 possible module addresses on a SLC loop (99 on CLIP loops). It responds to regular polls from the control panel and reports its type and status, including the open/normal/short status of its Notification Appliance Circuit (NAC). The LED blinks with each poll received. On command, it activates its internal relay. The FCM-1(A) supervises Class B (Style Y) or Class A (Style Z) notification or control circuits.

Upon code command from the panel, the FCM-1(A) will disconnect the supervision and connect the external power supply in the proper polarity across the load device. The disconnection of the supervision provides a positive indication to the panel that the control relay actually turned ON. The external power supply is always relay isolated from the communication loop so that a trouble condition on the external power supply will never interfere with the rest of the system.

Rotary switches set a unique address for each module. The address may be set before or after mounting. The built-in TYPE CODE (not settable) will identify the module to the control panel, so as to differentiate between a module and a sensor address.

### Specifications for FCM-1(A)

**Normal operating voltage:** 15 to 32 VDC.

**Maximum current draw:** 6.5 mA (LED on).

**Average operating current:** 350  $\mu$ A direct poll, 375  $\mu$ A group poll with LED flashing, 485  $\mu$ A Max. (LED flashing, NAC shorted.)



Maximum NAC Line Loss: 4 VDC.

**External supply voltage (between Terminals T10 and T11):** Maximum (NAC): Regulated 24 VDC; Maximum (Speakers): 70.7 V RMS, 50W.

**Drain on external supply:** 1.7 mA maximum using 24 VDC supply; 2.2 mA Maximum using 80 VRMS supply.

**Max NAC Current Ratings:** For class B wiring system, the current rating is 3A; For class A wiring system, the current rating is 2A.

**Temperature range:** 32°F to 120°F (0°C to 49°C).

**Humidity range:** 10% to 93% non-condensing.

**Dimensions:** 4.5" (114.3 mm) high x 4" (101.6 mm) wide x 1.25" (31.75 mm) deep. Mounts to a 4" (101.6 mm) square x 2.125" (53.975 mm) deep box.

**Accessories:** SMB500 Electrical Box; CB500 Barrier

### Specifications for FRM-1(A)

**Normal operating voltage:** 15 to 32 VDC.

**Maximum current draw:** 6.5 mA (LED on).

**Average operating current:** 230 µA direct poll; 255 µA group poll.

**EOL resistance:** not used.

**Temperature range:** 32°F to 120°F (0°C to 49°C).

**Humidity range:** 10% to 93% non-condensing.

**Dimensions:** 4.5" (114.3 mm) high x 4" (101.6 mm) wide x 1.25" (31.75 mm) deep. Mounts to a 4" (101.6 mm) square x 2.125" (53.975 mm) deep box.

**Accessories:** SMB500 Electrical Box; CB500 Barrier

### Agency Listings and Approvals

In some cases, certain modules may not be listed by certain approval agencies, or listing may be in process. Consult factory for latest listing status.

- **UL:** S635
- **ULC:** S3705 (A version only)
- **FM Approved**
- **CSFM:** 7300-0028:0219
- **MEA:** 14-00-E
- **FDNY:** COA #6067, #6065

### Contact Ratings for FRM-1(A)

Current Rating	Maximum Voltage	Load Description	Application
3 A	30 VDC	Resistive	Non-Coded
2 A	30 VDC	Resistive	Coded
.9 A	110 VDC	Resistive	Non-Coded
.9 A	125 VDC	Resistive	Non-Coded
.5 A	30 VDC	Inductive (L/R=5ms)	Coded
1 A	30 VDC	Inductive (L/R=2ms)	Coded
.3 A	125 VAC	Inductive (PF=0.35)	Non-Coded
1.5 A	25 VAC	Inductive (PF=0.35)	Non-Coded
.7 A	70.7 VAC	Inductive (PF=0.35)	Non-Coded
2 A	25 VAC	Inductive (PF=0.35)	Non-Coded

**NOTE:** Maximum (Speakers): 70.7 V RMS, 50 W

### Product Line Information

**NOTE:** "A" suffix indicates ULC Listed model.

**FCM-1(A):** Intelligent Addressable Control Module.

**FRM-1(A):** Intelligent Addressable Relay Module.

**A2143-20:** Capacitor, required for Class A (Style Z) operation of speakers.

**SMB500:** Optional Surface-Mount Backbox.

**CB500:** Control Module Barrier — required by UL for separating power-limited and non-power limited wiring in the same junction box as FCM-1(A).

**NOTE:** For installation instructions, see the following documents:

- *FCM-1(A) Installation document I56-1169.*
- *FRM-1(A) Installation document I56-3502.*
- *Notifier SLC Wiring Manual, document 51253.*

Notifier® and FlashScan® are registered trademarks of Honeywell International Inc.

©2011 by Honeywell International Inc. All rights reserved. Unauthorized use of this document is strictly prohibited.



This document is not intended to be used for installation purposes.  
We try to keep our product information up-to-date and accurate.  
We cannot cover all specific applications or anticipate all requirements.  
All specifications are subject to change without notice.



Made in the U.S. A.

For more information, contact Notifier. Phone: (203) 484-7161, FAX: (203) 484-7118.  
[www.notifier.com](http://www.notifier.com)

# Multi-Voltage Conventional Relays



Miscellaneous

## General

Notifier's multi-voltage conventional relays are used for high-current switching applications such as fan and damper assembly control, door control, air handling unit controls, and other types of system interfacing.

The R-10T(A)/20T(A) and R-14T(A)/R-24T(A) models are multi-voltage relays with terminal strip field wiring connections, mounting track and hardware. The R-10T(A) is a single FORM-C (SPDT) relay with a red activation LED, and the R-14T(A) is a 4-gang 1 FORM-C (SPDT) relay with 4 red activation LEDs. The R-20T(A) is a single 2 FORM-C (DPDT) relay with red activation LED, and the R-24T(A) is a 4-gang 2 FORM-C (DPDT) relay with 4 red activation LEDs.

The R-10E(A)/R-20E(A) and R-14E(A)/R-24E(A) are similar to the T series track mount relays, but they are mounted into a steel enclosure. The enclosure has a removable front cover that provides easy access and a LED viewing hole on the top of the cover.

PR-1(A)/PR-2(A)/PR-3(A) are epoxy encapsulated multi-voltage relays. They are single pole double throw relays that use a red LED as a visible indication of relay coil energization. PR-3 is identical to PR-2 except it has an extra pair of wires for redundant power input.

Model EOLR-1(A) is an epoxy encapsulated single pole single throw, normally open relay that can be used as an end of line device in fire alarm systems, e.g. to supervise power supplies.

## Specifications

### R-10T(A)/R-14T(A)/R-20T(A)/ R-24(A)T

**Operating Voltage Range:** 18-35 VDC, 18-35 VAC, 115 VAC, 230 VAC.

**Operating Current:** 23 mA @ 24 VDC, 59 mA @ 24 VAC, 150 mA @ 120 VAC, 180 mA @ 240 VAC [R-10T(A)/R-14T(A)].

40 mA DC max. @ 24 VDC, 24 VAC, 92 mA @ 24 VAC, 220 mA @ 120 VAC, 260 mA @ 240 VAC [R-20T(A)/R-24T(A)]

**Humidity Range:** 10% to 93% (non-condensing).

**Dimensions:** R-10T(A)/ R-20T(A): 2.5"L x 3.35"W x 1.2"H.

R-14T(A)/R-24T(A): 10"L x 3.35"W x 1.2"H.

**Operating Temperature:** -40° F to 158° F (-40°C to 70°C)

**Contact Ratings:** 24 VDC: 7A with L/R = 5 mS.  
120 VAC: 10 A.  
120 VAC: 1/6 HP.  
230 VAC: 7 A.

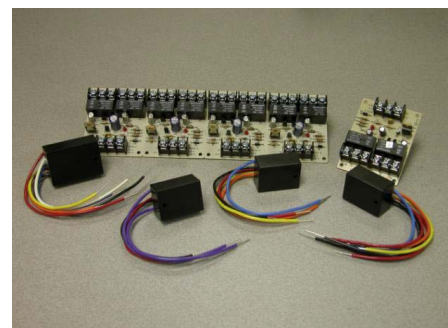

Multi-Voltage Conventional Relays

7015dn015g101

### R-10E(A)/ R-14E(A)/R-20E(A)/ R-24E(A)

**Operating Voltage Range:** 18-35 VDC, 18-35 VAC, 115 VAC, 230 VAC.

**Operating Current:** 23 mA DC max. @ 24 V, 59 mA @ 24 VAC, 150 mA @ 120 VAC, 180 mA @ 240 VAC [R-10E(A)/R-14E(A)].

-40 mA DC max. @ 24 VDC, 24 VAC, 115 VAC, 230 VAC (R-20E/R-24E).

**Humidity Range:** 10% to 93% (non-condensing).

**Dimensions:** R-10E(A)/R-20E(A): 5.1"L x 3.75"W x 2.5"H.

R-14E(A)/R-24E(A): 11"L x 5.3"W x 2.5"H.

**Operating Temperature:** -40° F to 158° F (-40° C to 70° C).

**Contact Ratings:** 24 VDC: 7 A with L/R = 5mS.  
120 VAC: 10 A.  
120 VAC: 1/6 HP.  
230 VAC: 7 A.

### PR-1(A)

**Operating Voltage Range:** 18-35 VDC, 18-35 VAC, 120 VAC.

**Operating Current:** 15 mA DC max. @ 24 VDC, 24 VAC, 120VAC.

**Humidity Range:** 10% to 93% RH.

**Dimensions:** 0.87" H x 2.01" W x 1.42" D.

**Operating Temperature:** -40° F to 158° F (-40° C to 70° C).

**Contact Ratings:** 24 VDC: 7 A with LR = 5 mS.  
120 VAC: 7 A max. (0.35 PF).  
250 VAC: 10 A resistive.  
30 VDC: 10 A resistive.

**Wire Length:** 8" minimum.

### **PR-2(A)/PR-3(A)**

<b>Operating Voltage Range:</b>	10 to 40 VDC.
<b>Operating Current:</b>	30 mA DC max.
<b>Humidity Range:</b>	10% to 93% RH.
<b>Dimensions:</b>	0.91" H x 1.65" W x 1.22" D.
<b>Operating Temperature:</b>	-40° F to 158° F (-40° C to 70° C).
<b>Contact Ratings:</b>	120 VAC: 10 A (resistive load). 120 VAC: 7 A max. (0.35 PF). 250 VAC: 10 A max. (resistive load). 30 VDC: 10 A max. (resistive load).
<b>Wire Length:</b>	8" minimum.

### **EOLR-1(A)**

<b>Operating Voltage Range:</b>	9 to 40 VDC.
<b>Operating Current:</b>	20 mA DC max.
<b>Humidity Range:</b>	10% to 93% RH.
<b>Operating Temperature:</b>	-22° F to 140° F (-30° C to 60° C).
<b>Contact Ratings:</b>	120 VAC: 0.5 A max. (resistive load). 30 VDC: 3 A max. (resistive load).
<b>Wire Length:</b>	8" minimum.

## **Agency Listings and Approvals**

In some cases, certain modules may not be listed by certain approval agencies, or listing may be in process. Consult factory for latest listing status.

- UL/ULC Listed: S3705
- ULC Listed: CS669
- MEA: 419-04-E
- CSFM: 7300-1653:173

## **PRODUCT LINE INFORMATION**

**NOTE:** "A" suffix indicates ULC listed model.

**PR-1(A):** Epoxy encapsulated single pull double throw (SPDT) relay. It also uses a red LED as a visible indication of relay coil energization with pigtailed.

**PR-2(A):** Epoxy encapsulated single pull double throw (SPDT) activated by 10 to 40 VDC. It uses a red LED as a visible indication of relay coil energization with pigtailed.

**PR-3(A):** Epoxy encapsulated single pull double throw (SPDT) activated by 10 to 40 VDC. It contains an additional black and red wire for redundant power input with pigtailed.

**EOLR-1(A):** Epoxy encapsulated single pull single throw (SPST) normally open relay that is activated by 9 to 40 VDC. This relay can be used as an end of line device in fire alarm systems, e.g., to supervise power supplies.

**R-10T(A):** Single (SPDT) relay with a red activation LED.

**R-14T(A):** 4-gang (SPDT) relay with 4 red activation LEDs.

**R-20T(A):** Single (DPDT) relay with a red activation LED.

**R-24T(A):** 4-gang (DPDT) relay with 4 red activation LEDs.

The R-10E(A)/R-20E(A) and R-14E(A)/R-24E(A) are similar to the T series track mount relays, but they are mounted into a steel enclosure. The enclosure has a removable front cover that provides easy access and a LED viewing hole on the top of the cover.

**R-10E(A):** Single (SPDT) relay mounted into a steel enclosure, 1 red activation LED.

**R-14E(A):** 4-gang (SPDT) relay mounted into a steel enclosure, 4 red activation LEDs.

**R-20E(A):** Single (DPDT) relay mounted into a steel enclosure, 1 red activation LED.

**R-24E(A):** 4-gang (DPDT) relay mounted into a steel enclosure, 4 red activation LEDs.



7015pr1.jpg

**PR-1(A)**



7015pr2.jpg

**PR-2(A)**

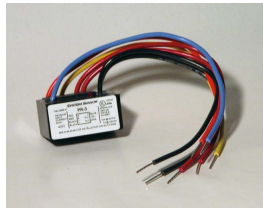

7015pr3.jpg

**PR-3(A)**

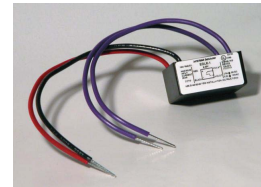

7015eolr1.jpg

**EOLR-1(A)**



7015r10t.jpg

**R-10T(A)**

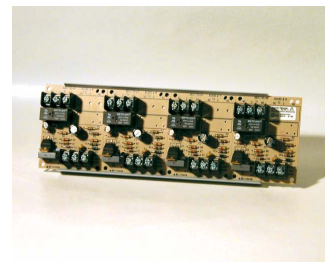

7015r14t.jpg

**R-14T(A)**

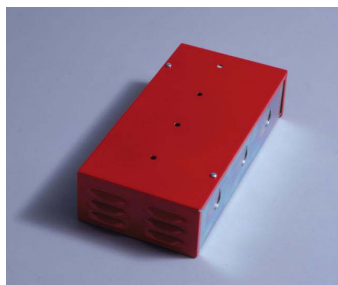

7015r20-24e.jpg

**R-20E(A) & R-24E(A)  
Enclosures**

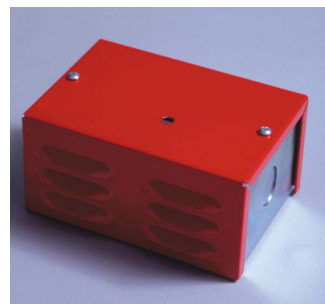

7015r10-14e.jpg

**R-10E(A) & R-14E(A)  
Enclosures**

---

©2013 by Honeywell International Inc. All rights reserved. Unauthorized use of this document is strictly prohibited.

---



This document is not intended to be used for installation purposes.  
We try to keep our product information up-to-date and accurate.  
We cannot cover all specific applications or anticipate all requirements.  
All specifications are subject to change without notice.

For more information, contact Notifier. Phone: (203) 484-7161, FAX: (203) 484-7118.  
[www.notifier.com](http://www.notifier.com)

# SpectrAlert® Advance

## Selectable Output Notification Appliances



### Audio/Visual Devices

#### General

System Sensor® SpectrAlert® Advance selectable-output horns, strobes and horn/strobes are rich with features guaranteed to cut installation times and maximize profits. The SpectrAlert Advance series of notification appliances is designed to simplify your installations, with features such as: plug-in designs, instant feedback messages to ensure correct installation of individual devices, and eleven field-selectable candela settings for wall and ceiling strobes and horn/strobes.

More specifically, when installing Advance products, first attach a universal mounting plate to a four-inch square, four-inch octagon, or double-gang junction box. The two-wire mounting plate attaches to a single-gang junction box.

Then, connect the notification appliance circuit wiring to the SEMS terminals on the mounting plate.

Finally, attach the horn, strobe, or horn/strobe to the mounting plate by inserting the product's tabs in the mounting plate's grooves. The device will rotate into position, locking the product's pins into the mounting plate's terminals. The device will temporarily hold in place with a catch until it is secured with a captured mounting screw.

#### SpectrAlert Advance products allow you to choose:

- 12 or 24 volts.
- 15, 15/75, 30, 75, 95, 110, 115, 135, 150, 177, or 185 candela by way of a rear-mounted slide switch and front viewing window.
- Horn tones and volume by way of a rotary switch.
- The SpectrAlert Advance series includes outdoor notification appliances. Outdoor strobes and horn/strobes (two-wire and four-wire) are available for wall or ceiling. Outdoor horns are available for wall only. All System Sensor outdoor products are rated between  $-40^{\circ}\text{F}$  and  $151^{\circ}\text{F}$  ( $-40^{\circ}\text{C}$  and  $66^{\circ}\text{C}$ ) in wet or dry applications.

#### Models available:

- Indoor wall-mount: horn, strobe, 2-wire horn/strobe, 4-wire horn/strobe.
- Indoor ceiling-mount: strobe, 2-wire horn/strobe, 4-wire horn/strobe.
- Outdoor wall-mount: horn, strobe, 2-wire horn/strobe, 4-wire horn/strobe.
- Outdoor ceiling-mount: strobe, 2-wire horn/strobe, 4-wire horn/strobe.

#### Features

- Plug-in design.
- Same mounting plate for wall- and ceiling-mount units.
- Shorting spring on mounting plate for continuity check before installation.
- Captive mounting screw.
- Tamper-resistance capability.
- Field-selectable candela settings on wall and ceiling units: 15, 15/75, 30, 75, 95, 110, 115, 135, 150, 177, 185.
- Automatic selection of 12 or 24 volt operation at 15 and 15/75 candela.
- Outdoor wall and ceiling products.



Indoor Ceiling  
Horn/Strobe



Outdoor Ceiling  
Strobe



Indoor Wall  
Horn/Strobe



Indoor Ceiling  
Strobe



Indoor Wall  
Horn



Outdoor Wall  
Strobe

- Outdoor products rated from  $-40^{\circ}\text{F}$  and  $151^{\circ}\text{F}$  ( $-40^{\circ}\text{C}$  and  $66^{\circ}\text{C}$ ).
- Outdoor products rainproof per UL50 (NEMA 3R) and weatherproof per NEMA 4X, IP56
- Minimal intrusion into the backbox.
- Horn rated at 88+ dbA at 16 volts.
- Rotary switch for tone selection.
- Three horn volume settings.
- Electrically compatible with existing SpectrAlert products.

#### Engineering Specifications

SpectrAlert Advance horns, strobes, and horn/strobes shall mount to a standard 4.0" x 4.0" x 1.5" (10.16 x 10.16 x 3.81 cm) backbox, 4.0" (10.16 cm) octagonal backbox, or a double-gang backbox. Two-wire products shall also mount to a single-gang 2.0" x 4.0" x 1.875" (5.08 x 10.16 x 4.763 cm) backbox. A universal mounting plate shall be used for mounting ceiling and wall products. The notification appliance circuit wiring shall terminate at the universal mounting plate. Also, SpectrAlert Advance products, when used with the Sync•Circuit™ Module accessory, shall be powered from a non-coded notification appliance circuit output and shall operate on a nominal 12 or 24 volts. When used with the Sync•Circuit Module, 12-volt rated notification appliance circuit outputs shall operate between 9 and 17.5 volts; 24-volt rated notification appliance circuit outputs shall operate between 17 and 33 volts. Indoor SpectrAlert Advance products shall operate between  $32^{\circ}\text{F}$  and  $120^{\circ}\text{F}$  ( $0^{\circ}\text{C}$  and  $49^{\circ}\text{C}$ ) from a regulated DC, or full-wave-rectified, unfiltered power supply. Strobes and horn/strobes shall have field-selectable candela settings including 15, 15/75, 30, 75, 95, 110, 115, 135, 150, 177, 185.

## STROBE

The strobe shall be a System Sensor SpectrAlert Advance Model \_\_\_\_\_ listed to UL 1971 and shall be approved for fire protective service. The strobe shall be wired as a primary-signaling notification appliance and comply with the Americans with Disabilities Act requirements for visible signaling appliances, flashing at 1 Hz over the strobe's entire operating voltage range. The strobe light shall consist of a xenon flash tube and associated lens/reflector system.

## HORN/STROBE COMBINATION

The horn/strobe shall be a System Sensor SpectrAlert Advance Model \_\_\_\_\_ listed to UL 1971 and UL 464 and shall be approved for fire protective service. The horn/strobe shall be wired as a primary-signaling notification appliance and comply with the Americans with Disabilities Act requirements for visible signaling appliances, flashing at 1 Hz over the strobe's entire operating voltage range. The strobe light shall consist of a xenon flash tube and associated lens/reflector system. The horn shall have three audibility options and an option to switch between a Temporal 3 pattern and a Non-Temporal (continuous) pattern. These options are set by a multiple position switch. On four-wire products, the strobe shall be powered independently of the sounder. The horn on horn/strobe models shall operate on a coded or non-coded power supply.

## OUTDOOR PRODUCTS

SpectrAlert Advance outdoor horns, strobes and horn/strobes shall be listed for outdoor use by UL and shall operate between -40°F and 151°F (-40°C and 66°C). The products shall be listed for use with a System Sensor outdoor/weather-proof backbox with half-inch and three-fourths-inch conduit entries.

## SYNCHRONIZATION MODULE

The module shall be a System Sensor Sync•Circuit MDL3R or MDL3W listed to UL 464 and shall be approved for fire protective service. The module shall synchronize SpectrAlert strobes at 1 Hz and horns at Temporal 3. Also, while operating the strobes, the module shall silence the horns on horn/strobe models over a single pair of wires. The module shall mount to a 4.688" x 4.688" x 2.125" (11.906 x 11.906 x 5.398 cm) backbox. The module shall also control two Style Y (class B) circuits or one Style Z (Class A) circuit. The module shall synchronize multiple zones. Daisy-chaining two or more synchronization modules together will synchronize all the zones they control. The module shall not operate on a coded power supply.

## Strobe Current Draw, UL Maximum (mA RMS)

Candela	8 – 17.5 V		16 – 33 V		
	DC	FWR	DC	FWR	
Standard Candela Range	15	123	128	66	71
	15/75	142	148	77	81
	30	NA	N/A	94	96
	75	NA	NA	158	153
	95	NA	NA	181	176
	110	NA	NA	202	195
	115	NA	NA	210	205
High Candela Range	135	NA	NA	228	207
	150	NA	NA	246	220
	177	NA	NA	281	251
	185	NA	NA	286	258

## Operating Specifications

- **Standard operating temperature:** 32°F to 120°F (0°C to 49°C).
- **K Series operating temperature:** -40°F to 151°F (-40°C to 66°C).
- **Humidity range:** 10% to 93% non-condensing (indoor products).
- **Strobe flash rate:** 1 flash per second.
- **Nominal voltage:** regulated 12 VDC/FWR or regulated 24 VDC/FWR. **NOTE:** Full Wave Rectified (FWR) voltage is a non-regulated, time-varying power source that is used on some power supply and panel outputs.
- **Operating voltage range:** 8 V to 17.5 V (12 V nominal); or 16 V to 33 V (24 V nominal). **NOTE:** P, S, PC, and SC products will operate at 12 V nominal only for 15 cd and 15/75 cd.
- **Input terminal wire gauge:** 12 to 18 AWG (3.31 to 0.821 mm<sup>2</sup>).
- **Ceiling-mount dimensions (including lens):** 6.8" diameter x 2.5" deep (17.3 cm diameter x 6.4 cm deep).
- **Wall-mount dimensions (including lens):** 5.6" H x 4.7" W x 2.5" D (14.2 cm H x 11.9 cm W x 6.4 cm D).
- **Horn dimensions:** 5.6" H x 4.7" W x 1.3" D (14.2 cm H x 11.9 cm W x 3.3 cm D).

## Agency Listings and Approvals

The listings and approvals below apply to SpectrAlert Advance Selectable Output Notification Devices. In some cases, certain modules may not be listed by certain approval agencies, or listing may be in process. Consult factory for latest listing status.

- **UL Listed:** S4011 (HR\_\_, HW\_\_, P2\_\_, P4\_\_, PC2\_\_, PC4\_\_ models); S5512 (models SCR, SCRH, SCW, SCWH, SR, SRH, SW, SWH); S3593 (SCRHK, SCRK, SRHK, SRK).
- **ULC Listed:** S4011 (HRA, HRKA); S5512 (typically "A" models, with exception of outdoor strobes). See Canadian data sheet for listings and specifications.
- **FM approved**
- **MEA: 452-05-E**
- **CSFM: 7125-1653:0186** (SCR, SCRH, SCW, SCWH, SR, SRH, SW, SWH); **7300-1653:0188** (P2\_, P4\_, PC2\_, PC4\_ modules); **7135-1653:0189** (HR, HRK, HW); **7300-1653:0187** (SCRHK, SCRK, SRHK, SRK).

## Horn Current Draw, UL Maximum (mA RMS)

Sound Pattern	dB	8 – 17.5 V		16 – 33 V	
		DC	FWR	DC	FWR
Temporal	High	57	55	69	75
Temporal	Medium	44	49	58	69
Temporal	Low	38	44	44	48
Non-temporal	High	57	56	69	75
Non-temporal	Medium	42	50	60	69
Non-temporal	Low	41	44	50	50
Coded	High	57	55	69	75
Coded	Medium	44	51	56	69
Coded	Low	40	46	52	50

### Horn and Horn/Strobe Rotary Switch Setting

Setting	Repetition Rate	dB Level
1	Temporal horn	High
2	Temporal horn	Medium
3	Temporal horn	Low
4	Normal horn	High
5	Normal horn	Medium
6	Normal horn	Low
7*	Externally coded	High
8*	Externally coded	Medium
9*	Externally coded	Low

*\*NOTE: Settings 7, 8, and 9 are not available on 2-wire horn/strobe.*

### Horn and Horn/Strobe Output (dBA)

Switch Position	Sound Pattern	dB	8 – 17.5 V		16 – 33 V	
			DC	FW R	DC	FW R
1	Temporal	High	78	78	84	84
2	Temporal	Medium	74	74	80	80
3	Temporal	Low	71	73	76	76
4	Non-temporal	High	82	82	88	88
5	Non-temporal	Medium	78	78	85	85
6	Non-temporal	Low	75	75	81	81
7*	Coded	High	82	82	88	88
8*	Coded	Medium	78	78	85	85
9*	Coded	Low	75	75	81	81

*\*NOTE: Settings 7, 8, and 9 are not available on 2-wire horn/strobe.*

### Two-Wire Horn/Strobe, **STANDARD** Candela Range (15 – 115 cd), UL Maximum Current Draw (mA RMS)

Input, Sound Pattern, dB Level	8 – 17.5 V		16 – 33 V						
	15	15/75	15	15/75	30	75	95	110	115
DC Input, Temporal, High	137	147	79	90	107	176	194	212	218
DC Input, Temporal, Medium	132	144	69	80	97	157	182	201	210
DC Input, Temporal, Low	132	143	66	77	93	154	179	198	207
DC Input, Non-temporal, High	141	152	91	100	116	176	201	221	229
DC Input, Non-temporal, Medium	133	145	75	85	102	163	187	207	216
DC Input, Non-temporal, Low	131	144	68	79	96	156	182	201	210
FWR Input, Temporal, High	136	155	88	97	112	168	190	210	218
FWR Input, Temporal, Medium	129	152	78	88	103	160	184	202	206
FWR Input, Temporal, Low	129	151	76	86	101	160	184	194	201
FWR Input, Non-temporal, High	142	161	103	112	126	181	203	221	229
FWR Input, Non-temporal, Medium	134	155	85	95	110	166	189	208	216
FWR Input, Non-temporal, Low	132	154	80	90	105	161	184	202	211

### Two-Wire Horn/Strobe, **HIGH** Candela Range (135 – 185 cd), UL Maximum Current Draw (mA RMS)

DC Input	16 – 33 V				FWR Input	16 – 33 V			
	135	150	177	185		135	150	177	185
DC, Temporal, High	245	259	290	297	FWR, Temporal, High	215	231	258	265
DC, Temporal, Medium	235	253	288	297	FWR, Temporal, Medium	209	224	250	258
DC, Temporal, Low	232	251	282	292	FWR, Temporal, Low	207	221	248	256
DC, Non-temporal, High	255	270	303	309	FWR, Non-temporal, High	233	248	275	281
DC, Non-temporal, Medium	242	259	293	299	FWR, Non-temporal, Medium	219	232	262	267
DC, Non-temporal, Low	238	254	291	295	FWR, Non-temporal, Low	214	229	256	262

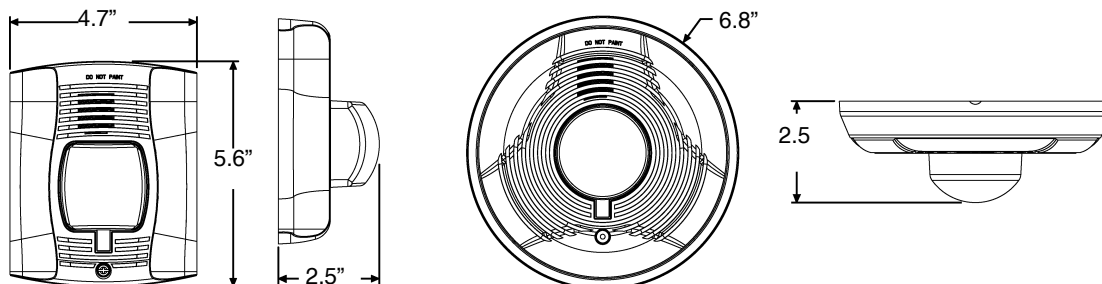

7087dim12009.tif



## Ordering Information

Model	Description	Model	Description
<b>WALL HORN/STROBES</b>		<b>CEILING HORN/STROBES</b>	
P2R	2-wire horn/strobe, standard cd, red.	PC2R	2-wire horn/strobe, standard cd, red.
P2RH	2-wire horn/strobe, high cd, red.	PC2RH	2-wire horn/strobe, high cd, red.
P2RK	2-wire horn/strobe, standard cd, red, outdoor.	PC2RK	2-wire horn/strobe, standard cd, red, outdoor.
P2RHK	2-wire horn/strobe, high cd, red, outdoor.	PC2RHK	2-wire horn/strobe, high cd, red, outdoor.
P2W	2-wire horn/strobe, standard cd, white.	PC2W	2-wire horn/strobe, standard cd, white.
P2WH	2-wire horn/strobe, high cd, white.	PC2WH	2-wire horn/strobe, high cd, white.
P4R	4-wire horn/strobe, standard cd, red.	PC4R	4-wire horn/strobe, standard cd, red.
P4RH	4-wire horn/strobe, high cd, red.	PC4RH	4-wire horn/strobe, high cd, red.
P4RK	4-wire horn/strobe, standard cd, red, outdoor.	PC4RK	4-wire horn/strobe, standard cd, red, outdoor.
P4RHK	4-wire horn/strobe, high cd, red, outdoor.	PC4RHK	4-wire horn/strobe, high cd, red, outdoor.
P4W	4-wire horn/strobe, standard cd, white.	PC4W	4-wire horn/strobe, standard cd, white.
P4WH	4-wire horn/strobe, high cd, white.	PC4WH	4-wire horn/strobe, high cd, white.
<b>WALL STROBES</b>		<b>CEILING STROBES</b>	
SR	Strobe, standard cd, red.	SCR	Strobe, standard cd, red.
SRH	Strobe, high cd, red.	SCRH	Strobe, high cd, red.
SRK	Strobe, standard cd, red, outdoor.	SCRK	Strobe, standard cd, red, outdoor.
SRHK	Strobe, high cd, red, outdoor.	SCRHK	Strobe, high cd, red, outdoor.
SW	Strobe, standard cd, white.	SCW	Strobe, standard cd, white.
SWH	Strobe, high cd, white.	SCWH	Strobe, high cd, white.
<b>ACCESSORIES</b>		<b>HORNS</b>	
BBS-2A	Backbox skirt, wall, red.	HR	Horn, red.
BBSW-2A	Backbox skirt, wall, white.	HRK	Horn, red, outdoor.
BBSC-2A	Backbox skirt, ceiling, red.	HW	Horn, white.
BBSCW-2A	Backbox skirt, ceiling, white.	<b>ACCESSORIES, continued</b>	
SA-WBB	Weatherproof backbox, wall.	TR-HS	Trim Ring, wall, red, package of 5
SA-WBBC	Weatherproof backbox, ceiling.	TRW-HS	Trim Ring, wall, white, package of 5
WTP	Weatherproof, flush mount plate, red	TRC-HS	Trim Ring, ceiling, red, package of 5
WTPW	Weatherproof, flush mount plate, white	TRCW-HS	Trim Ring, ceiling, white, package of 5
<p><b>NOTE:</b> "High cd" refers to strobes that include 135, 150, 177, and 185 candela settings. "Standard cd" refers to strobes that include 15, 15/75, 30, 75, 95, 110, and 115 candela settings.</p> <p><b>NOTE:</b> For strobes and horn/strobes, add suffix "F" for French or "B" for Bilingual.</p> <p><b>NOTE:</b> All outdoor models ("K(A)" suffix) include a plastic weatherproof backbox.</p> <p><b>NOTE:</b> Add "-R" to models for weatherproof replacement device (no back box included). Only for use with weatherproof outdoor flush mounting plate, WTP and WTPW.</p> <p><b>NOTE:</b> Add "P" to model for plain housing. (No "FIRE" marking on cover.)</p>			

SyncCircuit™ is a trademark and NOTIFIER® and SpectraAlert® are registered trademarks of Honeywell International Inc.  
 ©2011 by Honeywell International Inc. All rights reserved. Unauthorized use of this document is strictly prohibited.



This document is not intended to be used for installation purposes.  
 We try to keep our product information up-to-date and accurate.  
 We cannot cover all specific applications or anticipate all requirements.  
 All specifications are subject to change without notice.

For more information, contact Notifier. Phone: (203) 484-7161, FAX: (203) 484-7118.  
[www.notifier.com](http://www.notifier.com)

# 7788F/7744F Series

## Wireless Fire Alarm Communicators for AES-IntelliNet



### Features – All models

- UL Listed commercial fire alarm applications.
- Meets NFPA 72 requirements
- Direct reporting to AES receiver across IntelliNet wireless mesh network
- Each Subscriber acts as transmitter/receiver/repeater
- Simple and fast activation on network
- On board status LEDs for easy set up
- 8 programmable zone inputs – 7788F
- 4 programmable zone inputs and 4 reverse polarity inputs – 7744F
- Easy programming via AES handheld programmer or PC
- Rugged metal housing ideal for any commercial fire alarm application

### Models 7788F/7744F-ULP with IntelliPro Fire also includes

- IntelliPro Fire transmits full alarm data from virtually any fire alarm panel digital communicator
- Alarm format support for Contact ID, Pulse, or Bosch Modem IIe or Modem IIIa2
- Easy installation in AES subscriber
- Operates in applications with or without a phone line

### Advanced Wireless Alarm Monitoring

The AES-IntelliNet mesh radio network offers unmatched reliability and speed in delivering wireless alarm signals to a central station without third party fees or reliance on networks owned by companies outside the security and fire alarm industry. AES-7788F/7744F Series Smart Subscriber Transceivers provide the wireless communication link between the fire alarm panel and the central station receiver. The 7788F/7744F Series is ideal for most commercial fire alarm applications. Each 7788F/7744F Series Subscriber is housed in a full sized, red, locked, steel cabinet and supports a range of alarm panel inputs including EOL fire, EOL supervised, and direct voltage from the panel (non-fire applications).

### Supervised Operation

AES Smart Subscribers offer fully supervised operation that includes monitoring of operating power (both primary AC power and battery backup) and the connection to the radio network. Each Subscriber “checks in” with the AES central station receiver at least once every 24 hours. The supervision check in time can be set for as often as once per minute and, because the central station owns the wireless network, there is no additional cost for air time to transmit supervisory signals.

### Full Data Reporting from Alarm Panel Digital Dialer

Models 7788F-ULP and 7744F-ULP come equipped with an IntelliPro Fire Full Data Module (AES-7794) which enables reporting of full alarm data captured from the fire alarm panel's digital communicator. IntelliPro Fire supports most alarm communication formats including Contact ID, Pulse, as well as Bosch Modem IIe and Modem IIIa2.



Wireless mesh networking is an innovative technology adopted by many industries with applications that need to communicate data over a large geographic area with a high level of reliability at a low total cost of ownership.

The advanced design and 2-way communications capability provides easy installation, expansion, and management when compared to alternative communication methods, both wired and wireless.

# 7788F/7744F Series



## Technical Specifications

### 7788F/7744F Series Subscribers

#### Dimensions

- 13.25"H x 8.5"W x 4.3"D  
(34cm H x 21.5cm W x 11cm D)

#### Weight

- Approx. 7 pounds (3.2 kilograms), excludes battery.

#### Radio Frequency

- Standard Frequency Range: 450-470MHz (others available)
- Output Power - 2 Watts (others available)

#### Antenna

- Included 2.5 db tamper resistant antenna mounts on enclosure
- Multiple remote antenna options available

#### Power Input

- 16.5VAC, 40VA (transformer not included)

#### Backup Battery

- Will charge 12V battery up to 7.5 AH. Requires 12VDC 7.5 AH battery for UL 864.

#### Alarm Signal Inputs (subscriber)

- 7788F – 8 individually programmable zones
- 7744F - 4 individually programmable zones and 4 reverse polarity inputs

#### UL Standards

- UL 864 Edition 9 – Standard for Control Units and Accessories for Fire Alarm Systems
- UL 365 – Standard for Police Station Connected Burglar Alarm Units and Systems
- UL 1681 – Standard for Central Station Burglar Alarm Units

#### Antenna Cut / Communication

##### Trouble Output

- Form C relay; fail secure; rated for 24 VDC 1A resistive

##### Reset Button

- Located on main circuit board.

##### Operating Temperature

- 0° to 50° C (32° to 122°F)

##### Storage Temperature

- -10° to 60° C (14° to 140°F)

##### Relative Humidity

- 0 to 85% RHC, Non Condensing

### AES-7794 IntelliPro Fire

#### Input / Output Connections

- RJ11 connection to AES subscriber for module data and power
- RJ11 connector for Handheld Programmer/PC programming
- RJ31X Telco connections - T and R both in and out via terminal strip and RJ45
- Alarm Panel digital communicator T and R both in and out via terminal strip and RJ45
- Trouble output: Form C relay detects if Subscriber is off the network

#### Alarm Formats

- Support for Contact ID and Pulse formats as well as Modem IIe and Modem IIIa2 converted to CID

#### Size

- 2.8 x 5.0 inches (7.1cm x 12.7cm)

#### Power Requirements

- 12 VDC nominal - primary and backup power provided by the AES 7788F/7744F or other Subscriber

## How to Order

Model	Description
7744F	4 Zone Fire Alarm Subscriber with 4 reverse polarity inputs
7744F-ULP	7744F Fire Alarm Subscriber with IntelliPro Fire full data module
7788F	8 Zone Fire Alarm Subscriber
7788F-ULP	7788F Fire Alarm Subscriber with IntelliPro Fire full data module

## Optional Accessories

7041E	Subscriber Handheld Programmer
7794	IntelliPro Fire Full Data Module



AES-IntelliNet™ is the industry leader in delivering high quality wireless mesh networks to the fire and security industry in commercial, corporate, government, and educational applications with its broad line of products and advanced network management tools. Users of AES-IntelliNet networks have gained significant revenue, communications, and cost advantages while meeting the high standards of reliability required for the fire and security industry. AES-IntelliNet alarm monitoring systems are deployed at hundreds of thousands of locations in over 150 countries.



For more information

Call 800-AES-NETS (800-237-6387)

AES Corporation | 285 Newbury Street | Peabody, MA 01960 USA

Tel. +1 978-535-7310 | Fax +1 978-535-7313 | Email [info@aes-intellinet.com](mailto:info@aes-intellinet.com)

Web [www.aes-intellinet.com](http://www.aes-intellinet.com)

Copyright 2011 AES Corporation  
AES-IntelliNet is a registered trademark  
of AES Corporation

7788F-7744F/9/7/11R3

### High Security Industrial/Government Key Box



The number one high-security KNOX-BOX<sup>®</sup> is used for most commercial applications including businesses, schools, government and public buildings, community associations and apartment complexes. The 3200 Series KNOX-BOX with lift-off door holds keys, access cards and other small items necessary for emergency access.

#### Features and Benefits

- Holds up to 10 keys and access cards in interior compartment
- Ensures high security. Box and lock are UL<sup>®</sup> Listed
- Includes a Knox-Coat<sup>®</sup> proprietary finishing process that protects Knox products up to four times better than standard powder coat
- Resists moist conditions with a weather resistant door gasket
- Colors: Black, Dark Bronze or Aluminum
- Weight: Surface mount - 8 lbs.  
Recessed mount - 9 lbs.

#### Options

- Alarm tamper switches (UL Listed)
- Recessed Mounting Kit (RMK) for recessed models only
- Inside switch for use on electrical doors, gates and other electrical equipment

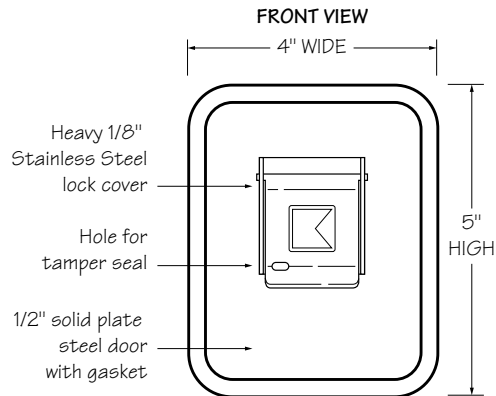

**3200 Surface Mount**

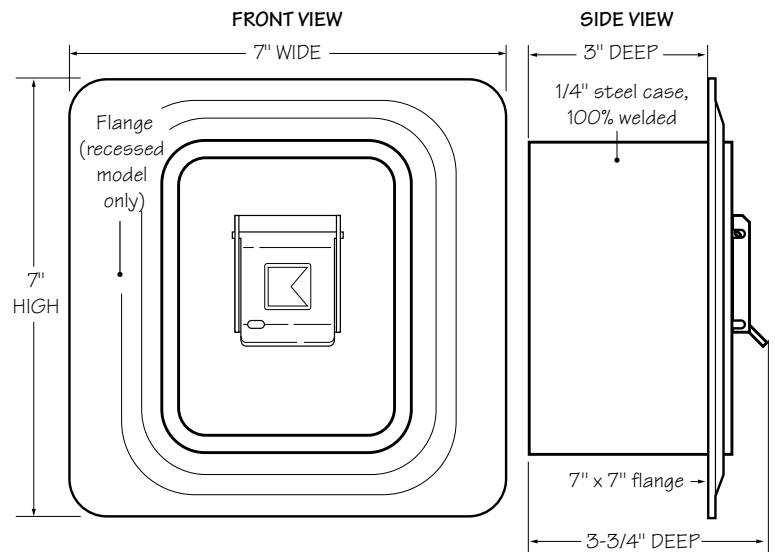

**3200 Recessed Mount**

#### Ordering Specifications

**To insure procurement and delivery of the 3200 Series KNOX-BOX, it is suggested that the following specification paragraph be used:**

**KNOX-BOX** surface/recessed mount with lift-off door, with/without UL Listed tamper switches. 1/4" plate steel housing, 1/2" thick steel door with interior gasket seal. Box and lock UL Listed. Lock has 1/8" thick stainless steel dust cover with tamper seal mounting capability.

Exterior Dimensions: Surface mount body - 5"H x 4"W x 3-3/4"D  
Recessed mount flange - 7"H x 7"W

Lock: UL Listed. Double-action rotating tumblers and hardened steel pins accessed by a biased cut key.

Finish: Knox-Coat<sup>®</sup> proprietary finishing process

Colors: Black, Dark Bronze or Aluminum

P/N: 3200 Series KNOX-BOX (mfr's cat. ID)

Mfr's Name: **KNOX COMPANY**

**Suggested minimum mounting height  
6 feet above ground**

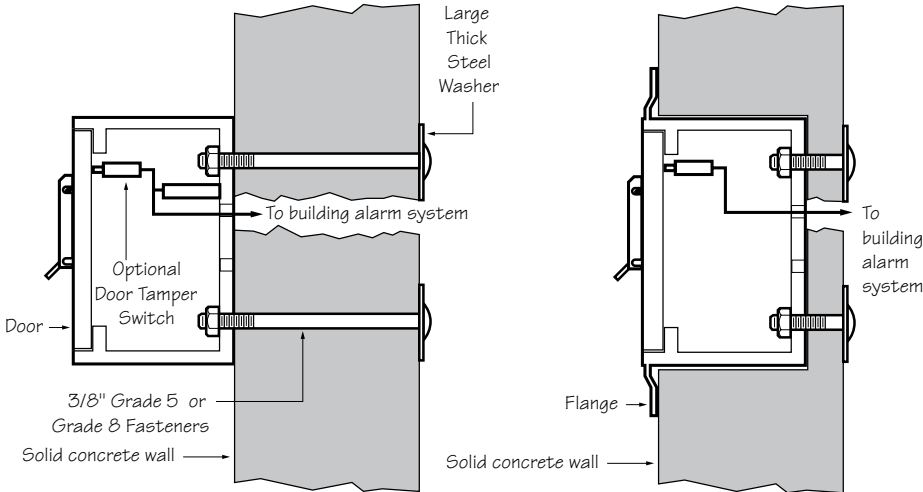

**3200 Series Lift-off Door  
Surface Mount**

**3200 Series Lift-off Door  
Recessed Mount**

**Inside View**

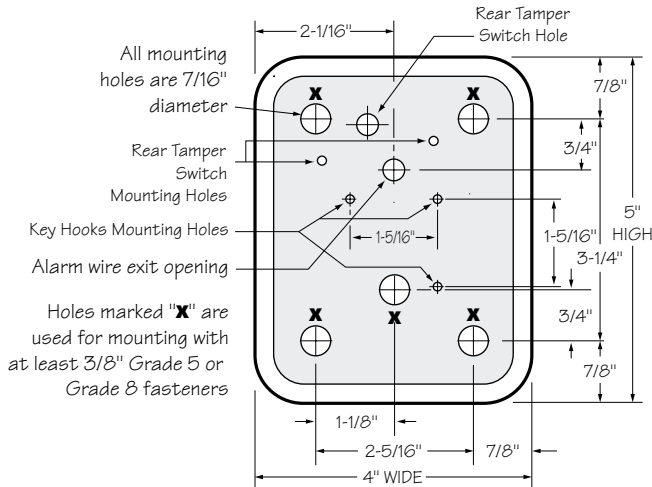

**Attention: KNOX-BOX<sup>®</sup> is a very strong device that MUST be mounted properly to ensure maximum security and resist physical attack.**

**Knox<sup>®</sup> Rapid Entry System**

The Knox Company manufactures a complete line of high security products including Knox-Box key boxes, key vaults, cabinets, key switches, padlocks, locking FDC caps, plugs and electronic master key security systems. For more information or technical assistance, please call Customer Service at 1-800-552-5669.

**Recessed Mounting Kit**

The 3200 Recessed Mounting Kit (RMK) is used for recessed models only. It contains a shell housing and mounting hardware to be cast-in-place in new concrete or masonry construction. After construction is completed, the KNOX-BOX mounts inside the recessed shell housing. The RMK may only be used in new concrete or masonry construction.

**Installation In Cast Concrete**

The optional Recessed Mounting Kit is for use in new concrete or masonry construction only. The kit includes a shell housing and mounting hardware to be cast-in-place. The KNOX-BOX is mounted into the shell housing after construction is completed.

**Dimensions**

Rough-in Dimensions: 6-1/2"H x 6-1/2"W x 5"D

**IMPORTANT: Care should be taken to insure that the front of the RMK shell housing, including the cover plate and screw heads, is flush with the finish wall. The RMK must be plumbed to insure vertical alignment of the vault.**

**Recessed Mounting Using  
Recessed Mounting Kit (RMK)**

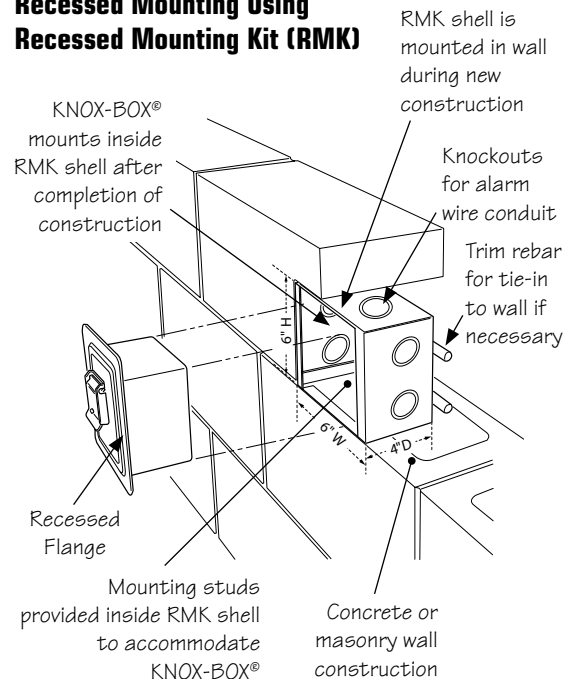

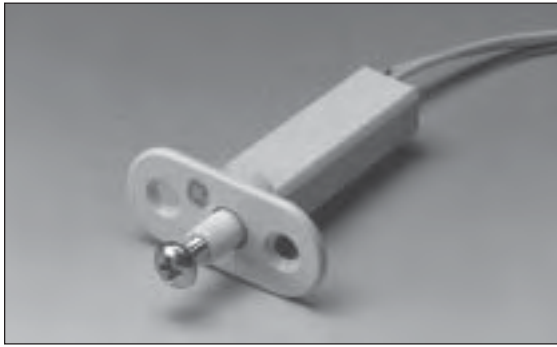

# Recessed Pin Plunger

## 3010 Series

### Applications

- Model 3015 available in plate mount or clip mount configuration
- Model 3025 plunger self-adjusts to proper reach
  - Pulling out on plunger shuts switch
  - Disconnection while servicing equipment is unnecessary

### General Specifications

Enclosure	ABS plastic
Temperature Range	-40°F to 150°F (-40°C to 65°C)
Environmental	Contact Housing is made of flame-retardant ABS plastic. Reed switch is protected and held in place by a polyurethane potting material
NEMA Rating	1
Protection Class	IP 62
Response Time	1 msec max.
Life Cycles	100,000 Under Full Load, 10,000,000 Under Dry Circuit
Lead Types/O.D.	#22 wire / 0.05" (0.15cm)
Color Choices	Natural(N), Mahogany(M)
UL Listed	All Models

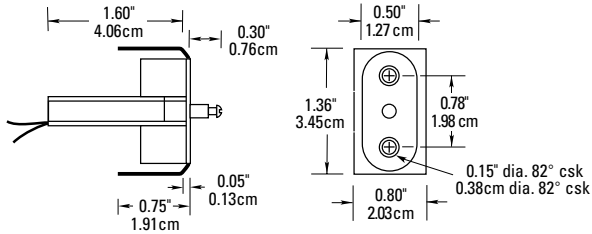

3012 Clip Mount Plunger

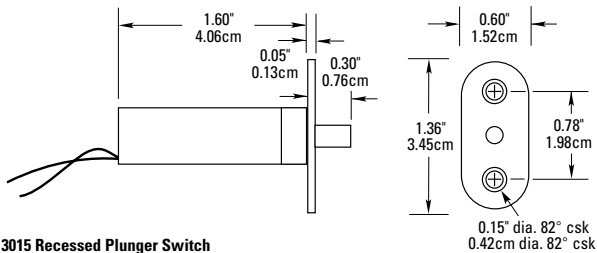

3015 Recessed Plunger Switch

Includes: 1- Adjustable #6 x 32 1/2" Phillips screw

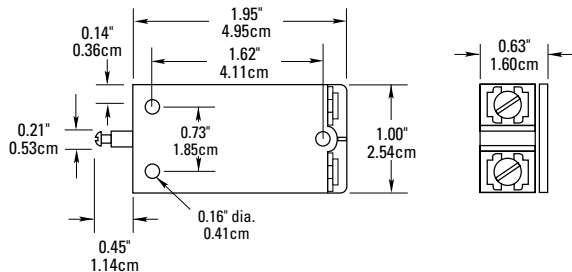

3025 Tamper Switch



Order Information		Electrical Specifications				
Part Number	Contact Configuration	Load Rating (AC/DC)	Switching Voltage (AC/DC)	Switching Current (AC/DC)	Contact Resistance	Lead Length
3012-M, N	N.O.	7.5W/VA	100V	0.5A	0.2 Ohms	1'
3015-M, N	N.O.	7.5W/VA	100V	0.5A	0.2 Ohms	1'
3027-M, N	SPDT	3W/VA	30V	0.25A	0.2 Ohms	1'
3025T-M, N	N.O.	7.5W/VA	100V	0.5A	0.2 Ohms	#6 Screw Terminal

Warning— Each electrical rating is an individual maximum and cannot be exceeded!

<sup>1</sup> Configuration with plunger out.

**NO  
EXCUSES!**

SIGNALING



## SYSTEM RECORD DOCUMENTS

The SRD is the perfect item to help you meet demanding code requirements today. NFPA 72 2013 7.7.2.4 states that a cabinet must be "prominently labelled 'SYSTEM RECORD DOCUMENTS'."

The SRD is the perfect fit to meet today's demanding code requirements. SAE's number one goal is to manufacture code compliant solutions and this product allows you to do just that. NFPA 72 2013 7.7.2.1 states, "With every new system, a documentation cabinet shall be installed at the system control unit or other approved location at the protected premises."

This durable 16 gauge steel enclosure with a solid piano hinge and key lock will keep all of your code required documents in one safe place. With a 4GB USB flash drive it stores your fire alarm software safe and secure eliminating the occurrences of the software not being on site when technicians arrive to service the system. Along with your fire alarm software you can store your test & inspection, service records, manuals & system records. Using a standard USB B connector you may also store your records electronically (See NFPA 72 2013 7.5.6.7).

The SRD has designated hooks to organize key rings and hold important business cards for easy access and reference. Inside the cover it has an organized record for identifying equipment information, required documentation locations (See NFPA 72 2013 7.2.1).

### Standard Features:

- Installed with a 4 GB digital flash drive with USB B connector
- 2 key ring hooks to hold system keys
- Business card holder for key contacts
- Overall dimensions are 12" x 13" tall and 2 1/4" deep
- 18 gauge steel box and cover for security
- Durable powder coat baked on finish other colors available
- Standard 3/4" cat 30 key lock. Other lock assemblies available
- Solid stainless steel piano hinge
- Permanently screened white ink 1" high "SYSTEM RECORD DOCUMENTS"
- Legend sheet for documentation, passwords and system information



ISO 9001  
REGISTERED  
COMPANY

**ACEBOX**

Space Age Electronics, Inc.  
www.1sae.com  
800.486.1723 Toll Free  
508.485.0966 Local  
508.485.4740 Fax

# Specifications:

The system record documents box (SRD) shall be UL Listed, constructed of 18 gauge cold rolled steel. It shall have a red powder coat epoxy finish. The cover shall be permanently screened with 1" high lettering "SYSTEM RECORD DOCUMENTS " with white indelible ink. The access door shall be locked with a 3/4" barrel lock and the hinge shall be a solid width 12" stainless steel piano hinge. The enclosure will supply 4 mounting holes. Inside the enclosure will accommodate standard 8 1/2 x 11 manuals and loose document records that will be protected within the enclosure. A legend sheet will be permanently attached to the door for system required documentation, key contacts and system information. The SRD will have securely mounted inside a minimum of 4 Gigabyte digital flash memory drive with a standard USB B connector for uploading and downloading information. The drive shall not be accessible without tools to any person whom gains access to the records. The enclosure shall also provide 2 key ring holders with a location to mount standard business type cards for key contact personnel.

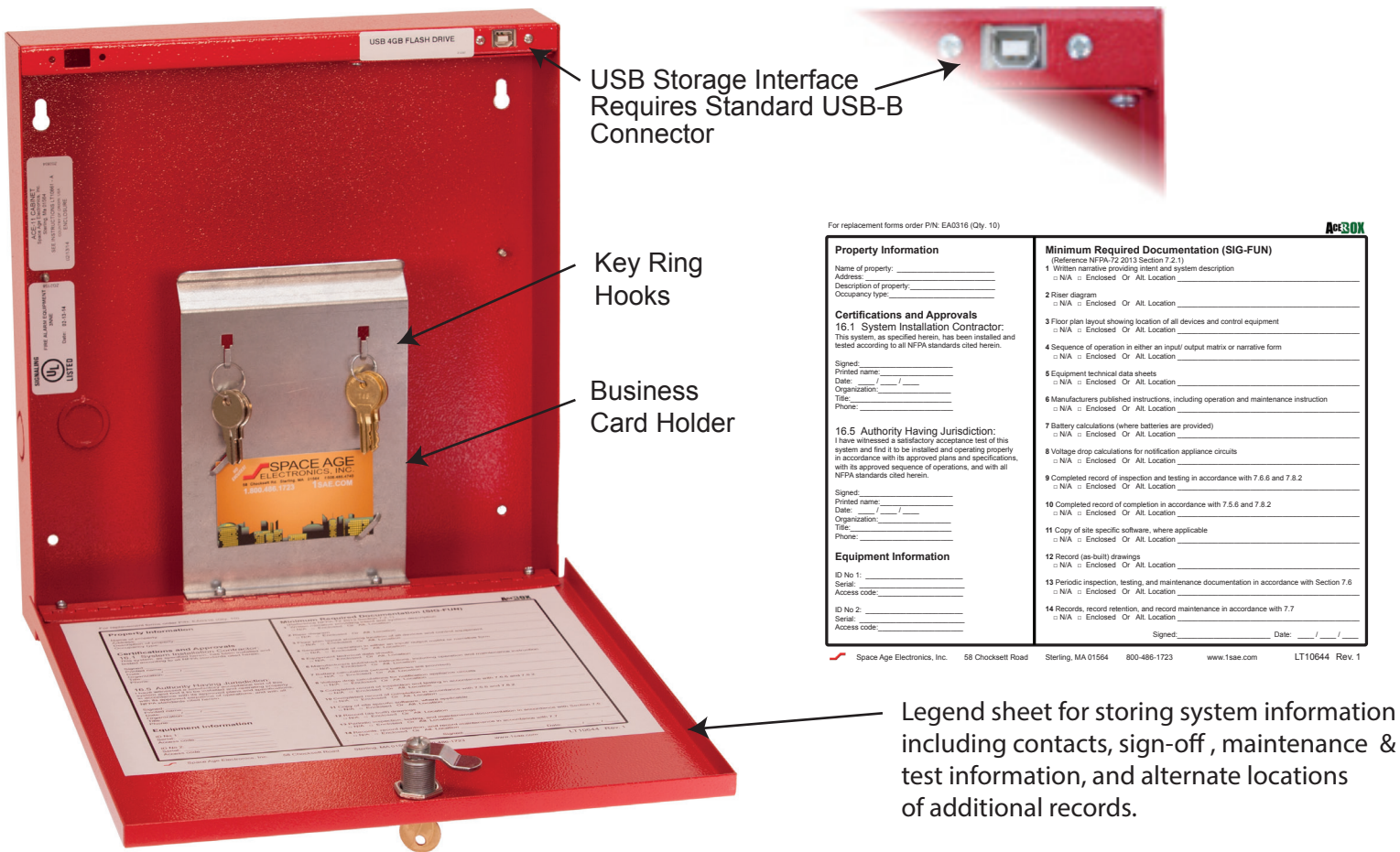

For replacement forms order PIN: EA0316 (Qty. 10)

Property Information	Minimum Required Documentation (SIG-FUN)
Name of property: _____	1 Written narrative providing intent and system description <input type="checkbox"/> N/A <input type="checkbox"/> Enclosed <input type="checkbox"/> All Location _____
Address: _____	2 Riser diagram <input type="checkbox"/> N/A <input type="checkbox"/> Enclosed <input type="checkbox"/> All Location _____
Description of property: _____	3 Floor plan layout showing location of all devices and control equipment <input type="checkbox"/> N/A <input type="checkbox"/> Enclosed <input type="checkbox"/> All Location _____
Occupancy type: _____	4 Sequence of operation in either an input/output matrix or narrative form <input type="checkbox"/> N/A <input type="checkbox"/> Enclosed <input type="checkbox"/> All Location _____
<b>Certifications and Approvals</b>	
<b>16.1 System Installation Contractor:</b> This system, as specified herein, has been installed and tested according to all NFPA standards cited herein.	
Signed: _____	5 Equipment technical data sheets <input type="checkbox"/> N/A <input type="checkbox"/> Enclosed <input type="checkbox"/> All Location _____
Printed name: _____	6 Manufacturers published instructions, including operation and maintenance instruction <input type="checkbox"/> N/A <input type="checkbox"/> Enclosed <input type="checkbox"/> All Location _____
Date: ____/____/____	7 Battery calculations (where batteries are provided) <input type="checkbox"/> N/A <input type="checkbox"/> Enclosed <input type="checkbox"/> All Location _____
Organization: _____	8 Voltage drop calculations for notification appliance circuits <input type="checkbox"/> N/A <input type="checkbox"/> Enclosed <input type="checkbox"/> All Location _____
Title: _____	9 Completed record of inspection and testing in accordance with 7.6.6 and 7.8.2 <input type="checkbox"/> N/A <input type="checkbox"/> Enclosed <input type="checkbox"/> All Location _____
Phone: _____	10 Completed record of completion in accordance with 7.5.6 and 7.8.2 <input type="checkbox"/> N/A <input type="checkbox"/> Enclosed <input type="checkbox"/> All Location _____
<b>16.5 Authority Having Jurisdiction:</b> I have witnessed a satisfactory acceptance test of this system and find it to be installed and operating properly in accordance with its approved plans and specifications, with its approved sequence of operations, and with all NFPA standards cited herein.	
Signed: _____	11 Copy of site specific software, where applicable <input type="checkbox"/> N/A <input type="checkbox"/> Enclosed <input type="checkbox"/> All Location _____
Printed name: _____	12 Record (as-built) drawings <input type="checkbox"/> N/A <input type="checkbox"/> Enclosed <input type="checkbox"/> All Location _____
Date: ____/____/____	13 Periodic inspection, testing, and maintenance documentation in accordance with Section 7.6 <input type="checkbox"/> N/A <input type="checkbox"/> Enclosed <input type="checkbox"/> All Location _____
Organization: _____	14 Records, record retention, and record maintenance in accordance with 7.7 <input type="checkbox"/> N/A <input type="checkbox"/> Enclosed <input type="checkbox"/> All Location _____
Title: _____	Signed: _____ Date: ____/____/____
Phone: _____	
<b>Equipment Information</b>	
ID No 1: _____	
Serial: _____	
Access code: _____	
ID No 2: _____	
Serial: _____	
Access code: _____	

## Ordering Information:

Part #	Description
SSU00689	System Record Documents Cabinet RED
SSU00690	Custom screening with your Logo
EA0315	10 pack door legend sheet



Space Age Electronics, Inc.  
www.1sae.com  
800.486.1723 Toll Free  
508.485.0966 Local  
508.485.4740 Fax

This document is subject to change without notice, see doc # ED0479 for legal disclaimer





# GENTEX CORPORATION

## Combination Photoelectric Smoke and Carbon Monoxide Alarm

### 120VAC/9VDC Single/Multiple Station Smoke and CO Alarm

## GN - 503 S E R I E S

### Applications

The GN-503 (120VAC/9VDC) Series of combination photoelectric smoke and electrochemical sensor carbon monoxide alarms are for use as evacuation devices in all dwelling units, including but not limited to homes, apartments, hospitals, hotels, motels and other commercial occupancies. The GN-503 Series is listed in compliance with ANSI/UL 217, ANSI/UL 2034, for installation per NFPA 720 and NFPA 72.

Available in three models, the GN-503 Series is engineered to virtually eliminate nuisance alarms and deliver outstanding performance wherever reliable smoke and CO protection is required. The GN-503F features one (1) set of Form A/Form C contacts that activate for smoke and/or CO events. **THE GN-503FF FEATURES TWO (2) SETS OF FORM A/ FORM C CONTACTS THAT ACTIVATE INDEPENDENTLY FOR SMOKE AND CO EVENTS.** Both the GN-503F and GN-503FF provide a connection to a protected premises alarm system to provide a supervisory/trouble signal.

The GN-503 Series is provided with a 9VDC alkaline battery for electrical back-up in the event building power is lost. The battery impedance is verified and the alarm provides a low or missing battery warning. The battery drawer provides easy replacement without removing the unit from the wall or ceiling.

The GN-503 Series is designed with a self test feature that quickly notifies if the alarm is functioning properly or needs attention (signified by a series of chirps) by simply pressing the test button. The functionality tests that the smoke/CO alarm is operating properly (signified by going into alarm). The self and functionality tests are in compliance with NFPA 72, NFPA 720 and ANSI/UL Standards.

The GN-503 Series provides a temporal 3 evacuation tone for smoke alarm annunciation and all units provide a temporal 4 tone for CO alarm annunciation. Per NFPA 720, the temporal 3 evacuation tone for smoke alarm will take precedence over the temporal 4 tone for CO alarm.



### Product Listings

SIGNALING



LISTED



- ANSI/UL 217 and ANSI/UL 2034 Listed
- CSFM # 5276-0569:144

### Product Compliance



- NFPA 72 and NFPA 720
- IBC/IFC/IRC
- City & State Ordinances/Laws/Regulations
- Quality Management System is certified to: ISO 9001:2008

### Standard Product Features

- GN-503 available in 120VAC with 9VDC battery back-up
- Horn frequency 3100 Hz (nominal)
- Meets sensitivity requirements of ANSI/UL 2034
- F Model: One (1) set of Form A/Form C contacts that activate for smoke and/or CO events
- FF Model: **Two (2) sets of Form A/Form C contacts that activate independently for smoke and CO events**
- Relay contacts operate on battery back-up
- Push button self test feature
- Push button functional test feature
- Quick-disconnect wiring harness
- Non-latching (self restoring) alarm
- Fully insect protected
- Red LED pulses every 30 seconds, green LED for AC power on

- Mounting hardware adapts to standard junction boxes, including but not limited to 4x4x2-1/8 octagon
- Dust cover to prevent contamination during installation
- Low or missing battery indicator
- 1 year warranty from date of purchase
- 5 year limited warranty on CO sensor

### Additional Smoke Alarm Features

- Photoelectric smoke sensing technology
- Temporal 3 evacuation sounding pattern for smoke annunciation
- Nominal 2.5% sensitivity (smoke)
- Solid state red LED to indicate smoke presence

### Additional CO Alarm Features

- Electrochemical sensor
- Temporal 4 sounding pattern for CO annunciation
- End of life signal indicates CO sensor has reached depletion state and unit must be replaced

## GN-503 Series Combination Smoke/CO Alarm

Model Number	Voltage	9VDC Battery Back-Up	One (1) Set Form A/ Form C Relay Contacts	Two (2) Sets Form A/ Form C Relay Contacts
GN-503	120VAC	●		
GN-503F	120VAC	●	●	
GN-503FF	120VAC	●		●

### GN-503 AND GN-503F Wiring Diagrams

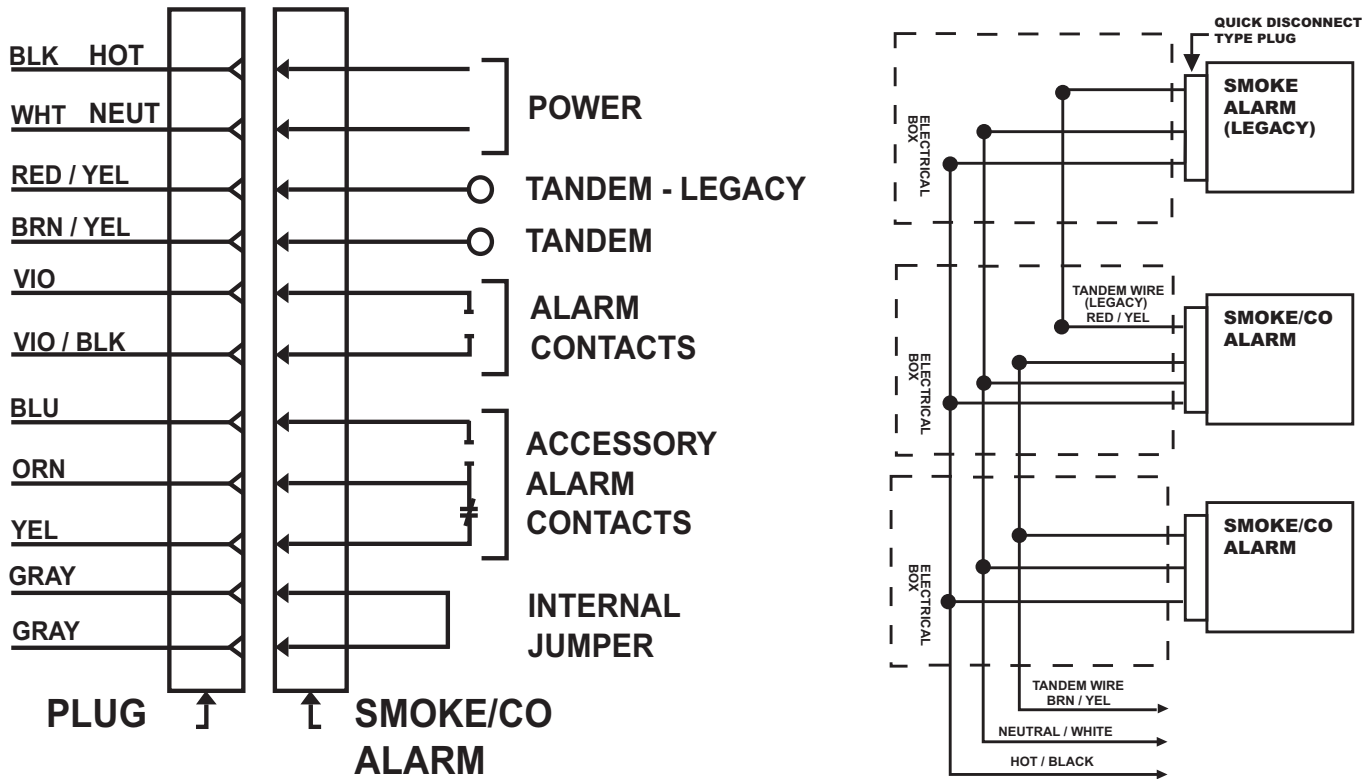

### GN-503/GN-503F ADDITIONAL PRODUCT INFORMATION

THE GN-503F AND GN-503FF PRODUCT WIRING HARNESS IS NOT INTERCHANGEABLE. THE GN-503F AND GN-503FF MUST USE PROPER WIRING HARNESS. PRODUCT WILL NOT FUNCTION IF INCORRECT HARNESS IS USED.

- DO NOT connect Gentex alarms to other manufacturers' alarms.
- Per NFPA 72, a maximum of 18 compatible smoke, heat, CO and/or combination smoke/CO alarms may be interconnected. No more than 12 of the 18 can be smoke alarms.
- All units connected in tandem MUST get their power from the same circuit, that is, all smoke alarms in tandem must be controlled by the same fuse or circuit breaker.

**NOTICE:** PER NFPA 72, A MAXIMUM OF 12 SMOKE/CO ALARMS OF GN-503 WITH THE RELAY OPTION (F) MAY BE TANDEM INTERCONNECTED.

The GN-503/GN-503F may be tandem interconnected with other Gentex tandem capable smoke alarms, CO alarms or smoke/CO alarms. To interconnect with Gentex 9000 Series, 7000 Series, 710CS Series, 7109CS Series, GN-200 Series & GN-300 Series the LEGACY TANDEM WIRE must be used. Refer to installation manual for detailed information.

**CAUTION:** RED/YELLOW & BROWN/YELLOW wire to be capped when not in use. This wire is for tandem connection only. Do not connect to any other circuit.

- If a GN-503 Series or CO1209 Series unit is annunciating for a CO event, legacy products that are tandem interconnected will not activate and will remain silent.
- If smoke alarm portion of device goes into alarm, all smoke alarms, CO alarms or combination smoke/CO alarms tandem wired will sound smoke alarm warning.
- When both smoke and CO conditions are present, smoke condition will have priority and alarm will sound smoke annunciation.

# USING THE GENTEX GN-503FF COMBINATION SMOKE AND CARBON MONOXIDE ALARM ALLOWS THE ABILITY TO:

- Interface with a FACP Panel
- Interface with NAC Circuits

## GN-503FF Wiring Diagrams

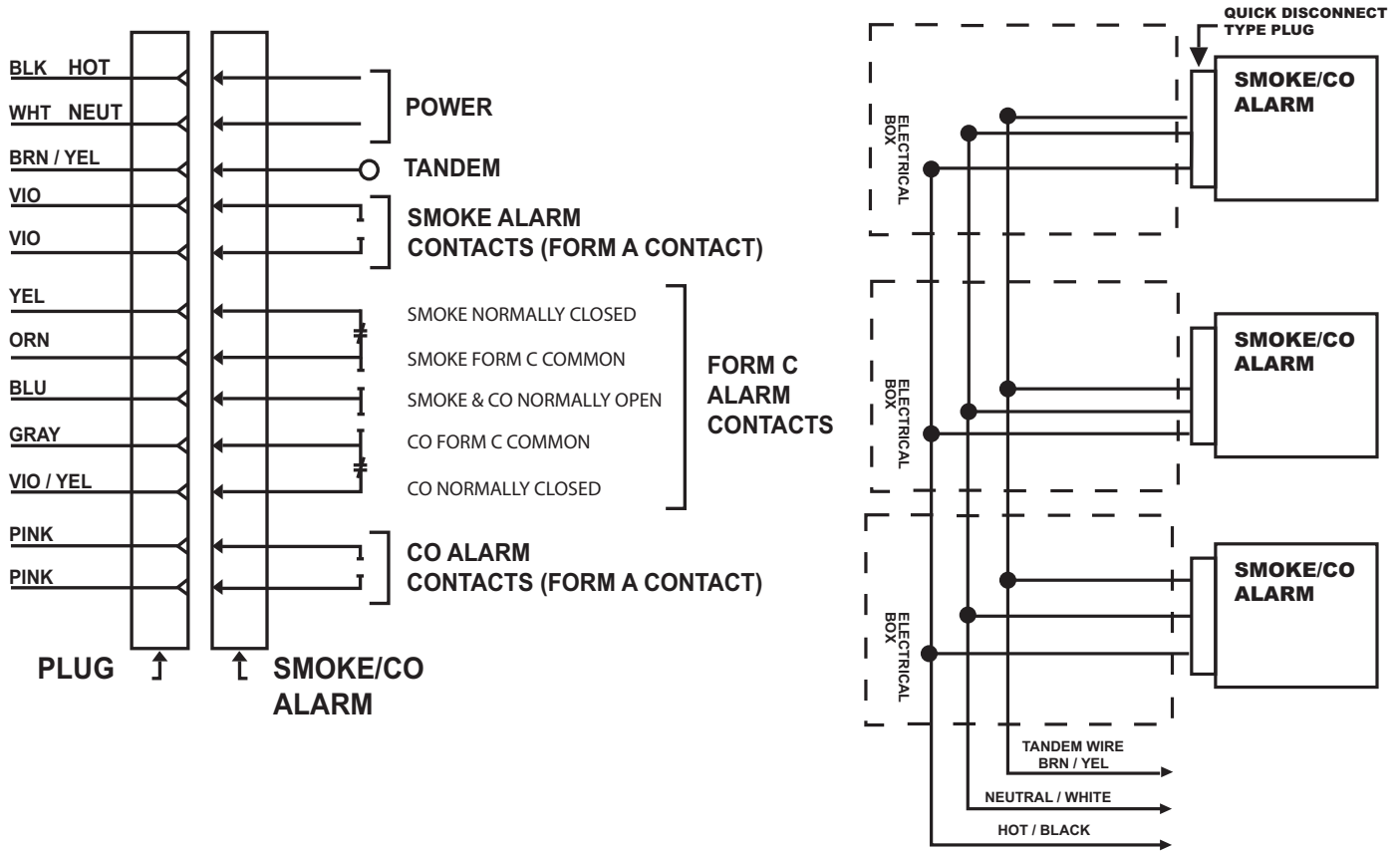

### GN-503FF ADDITIONAL PRODUCT INFORMATION

Use brown/yellow wire to tandem interconnect GN-503FF alarms to additional GN-503 Series, S1209 Series and CO1209 Series.

**NOTICE:** THE GN-503FF IS ONLY CAPABLE OF TANDEM INTERCONNECT WITH GN-503 SERIES, CO1209 SERIES AND S1209 SERIES.

THE GN-503F AND GN-503FF PRODUCT WIRING HARNESS IS NOT INTERCHANGEABLE. THE GN-503F AND GN-503FF MUST USE PROPER WIRING HARNESS. PRODUCT WILL NOT FUNCTION IF INCORRECT HARNESS IS USED.

- DO NOT connect Gentex alarms to other manufacturers' alarms.
- Per NFPA 72, a maximum of 18 compatible smoke, heat, CO and/or combination smoke/CO alarms may be interconnected. No more than 12 of the 18 can be smoke alarms.
- All units connected in tandem MUST get their power from the same circuit, that is, all smoke alarms in tandem must be controlled by the same fuse or circuit breaker.

**NOTICE:** PER NFPA 72, A MAXIMUM OF 12 SMOKE/CO ALARMS OF GN-503 WITH THE RELAY OPTION (FF) MAY BE TANDEM INTERCONNECTED.

**CAUTION:** BROWN/YELLOW wire to be capped when not in use. This wire is for tandem connection only. Do not connect to any other circuit.

- If smoke alarm portion of device goes into alarm, all smoke alarms, CO alarms or combination smoke/CO alarms tandem wired will sound smoke alarm warning.
- When both smoke and CO conditions are present, smoke condition will have priority and alarm will sound smoke annunciation.

# GN-503 SERIES

## Electrical Specifications

Operating Voltage .....	120VAC, 60Hz
Operating Current .....	.045 amps
Operating Current (Relay Options) .....	.070 amps
Operating Ambient Temp Range .....	40°F to 100°F (4.4°C-38°C)
Alarm Horn Rating .....	85dBA at 10 feet (3.048 m)
Auxiliary Relay (GN-503F) .....	1 Form A & 1 Form C (0.5 amp)
Auxiliary Relay (GN-503FF) .....	2 Form A & 2 Form C (0.3 amp)
Size .....	Diameter at base: 5.75 in. (14.605 cm)
.....	Overall diameter 6.25 in. (16.51 cm)
.....	Depth: 1.8 in. (4.572 cm)
Secondary Power Source .....	Alkaline 9VDC battery (Duracell® MN 1604)
CO Sensing Cell .....	Electrochemical Cell

## Architect & Engineering Specifications

The combination photoelectric smoke and carbon monoxide alarm shall be a Gentex Model GN-503/GN-503F/GN-503FF or approved equal which shall provide at least the following features and functions:

1. Nominal smoke sensitivity shall be 2.5%.
2. The smoke alarm portion of device shall utilize an infrared LED sensing circuit which pulses in 4 to 5 second intervals when subjected to smoke. After 2 consecutive pulses in smoke, the alarm shall activate.
3. The CO alarm shall utilize an electrochemical sensing element with a minimum 5-year life.
4. The carbon monoxide alarm portion of device is adjusted not to detect CO levels below 30 PPM and will not alarm when exposed to constant levels of 30 PPM for 30 days. Per ANSI/UL 2034 requirements, the device will alarm at the following levels: 70 PPM CO between 1 to 4 hours, but not less than 1 hour. 150 PPM CO between 10 to 50 minutes. 400 PPM between 4 to 15 minutes.
5. The GN-503 Series device shall have a Duracell® MN 1604 9VDC alkaline battery as a back-up in the event building power is lost.
6. The 9VDC battery impedance shall be verified by the circuit of the smoke/CO alarm.
7. The alarm shall provide an indicator when the battery is low in power, high impedance or is missing.
8. The CO alarm will provide an audible indicator of 3 quick chirps every 30 seconds at end of life of CO sensor.
9. The sensing chamber shall be fully protected to prevent entrance of small insects, thus reducing the probability of false alarms.
10. The alarm shall include a solid state red color LED that will indicate presence of CO at the unit.
11. The alarm shall include a solid state piezo alarm rated at 85dBA at 10ft.
12. A visual LED monitor (condition indicator) shall slow pulse in normal operation and rapid pulse in alarm (red color)
13. An easily accessible test button shall be provided. Push down on button for 5 seconds causing smoke/CO alarm to activate. If device does not go into alarm, the device is not working properly.
14. The device shall have tandem interconnect capability of up to 12 smoke/CO alarms.
15. The GN-503 and GN-503F alarm shall have the capability to tandem interconnect with all Gentex tandem capable smoke alarms, CO alarms or combination smoke/CO alarms, including 7000/7003 Series, 9000/9003 Series, 710CS/713CS Series, 7109CS/7139CS Series, GN-200/GN-300 Series, S1209 Series and CO1209 Series.
15. The GN-503FF alarm shall have the capability to tandem interconnect with the following Gentex alarms, CO alarms or combination smoke/CO alarms: GN-503 Series, S1209 Series and CO1209 Series.
16. The manufacturer shall provide models with the optional feature of auxiliary Form A/Form C relay contacts for initiating remote functions and annunciation and a relay option that is capable of activation by tandem interconnect wire.
17. The combination smoke/CO alarm shall be non-latching (self-restoring).
18. Unit must be ANSI/UL 217 and ANSI/UL 2034 listed for both wall and ceiling mounting.
19. Unit shall be listed by Underwriters Laboratories and California State Fire Marshal (CSFM).

All equipment shall be completely factory assembled, wired and tested, and the contractor shall be prepared to submit a certified letter testifying to this condition. Alarms which do not meet all of the requirements of this specification will not be considered.

For complete product specifications, refer to product installation manual.

24 units per carton
24 pounds per carton



Fire Protection Products Group • www.gentex.com  
10985 Chicago Drive • Zeeland, Michigan 49464  
616.392.7195 • 1.800.436.8391 • 616.392.4219 Fax

Gentex Corporation reserves the right to make changes to the product data sheet at their discretion.

### Important Notice:

These materials have been prepared by Gentex Corporation ("Gentex") for informational purposes only, are necessarily summary, and are not purported to serve as legal advice and should not be used as such. Gentex makes no representations and warranties, express or implied, that these materials are complete and accurate, up-to-date, or in compliance with all relevant local, state and federal laws, regulations and rules. The materials do not address all legal considerations as there is inevitable uncertainty regarding interpretation of laws, regulations and rules and the application of such laws, regulations and rules to particular fact patterns. Each person's activities can differently affect the obligations that exist under applicable laws, regulations or rules. Therefore, these materials should be used only for informational purposes and should not be used as a substitute for seeking professional legal advice. Gentex will not be responsible for any action or failure to act in reliance upon the information contained in this material.

551-0073-04

## Photoelectric Smoke Alarm with Visual Signaling Appliance

### Applications

The 710/713CS/LS and 7109/7139CS/LS photoelectric single/multiple station smoke alarms are designed to give reliable early warning of the presence of smoke where both audible and visual alarms are required. The series features a 90dBA solid state piezo signal and a 177 Candela strobe with "FIRE" lettering. The strobe is listed per UL 1971.

The smoke alarm operates on the light scattering principle, a superior method of detection in smoldering fires, utilizing a pulsing LED light source and a photodiode sensor in a fully screened sensing chamber.

Every 4 to 5 seconds the pulsing LED emits an infrared beam that by passes the photodiode under normal conditions. However, when smoke enters the sensing chamber, the infrared beam is deflected onto the sensor by the smoke particles. The LED pulse rate increases to 8 times the normal rate, and after the photodiode confirms that smoke is present for 2 consecutive pulses, it will produce the signal necessary to trip an alarm.

Upon activation, the alarm will emit a 90dBA local audible signal and activate the high intensity strobe. During the alarm period the strobe will flash at a brightness of 177 candela 60 times per minute. After the smoke has cleared from the detector, the unit will revert to the normal stand-by condition.

### Standard Features

- Available in 120VAC
- 177 candela rating (UL 1971 listed)
- Horn frequency 3100Hz (nominal)
- Patented three position test switch
- Nominal 2.5% Sensitivity
- Quick-Disconnect Wiring Harness (CS Models)
- Form C Auxiliary Relay Contacts for Remote Annunciation (CS Models)
- 9VDC Battery Back-Up (7109/7139CS/LS) w/Audible Low Battery Chirp
- 120VAC with 9VDC Battery Back-up Models, Visual Does Not Operate on Battery Back-Up
- Relays Operate on Battery Back-Up
- Relay Contacts Will Activate From the Tandem Wire
- 90dBA Continuous Piezo Horn (710CS/LS & 7109CS/LS Series)
- 90dBA Temporal 3 Evacuation Piezo Horn (713CS/LS & 7139CS/LS Series)
- 5-to-1 Signal-to-Noise Ratio
- Fully Insect Screened
- Interconnect with all Gentex tandem capable smoke alarms
- Interconnect up to 6 Alarms (CS Models)
- Easy Wash™ on-site maintenance washing program
- 9 Foot Line Cord (LS Models)
- Mounting Hardware Adapts to Standard Junction Boxes
- Warranty is 1 Year From Date of Purchase

## 710/713CS/LS 7109/7139CS/ S E R I E S



**Easy Wash™ -  
On Site  
Maintenance  
Program**

### Product Listings



- UL 217 and UL 1971 Listed
- CSFM: 7257-0569:104 (710/713CS/LS)  
7257-0569:118 (7109/7139CS/LS)
- BS+A/MEA: 285-91-E
- BFP (City of Chicago)
- MSFM Listing #1929

### Product Compliance

- NFPA 72
- Americans with Disabilities Act (ADA)



## 710CS/LS and 7109CS/LS Series - Continuous Piezo Sounder

Model Number	Part Number	Voltage	Wall Mount	Ceiling Mount	9 Foot Line Cord	Interconnect Up To 6 Units	Form C Contacts	9VDC Battery Back-Up
710CS-W	907-0231-002	120 VAC	●			●	●	
710CS-C	907-0232-002	120 VAC		●		●	●	
710CSX-W	907-0235-002	120 VAC	●			●	●	
710CSX-C	907-0236-002	120 VAC		●		●	●	
710LS	907-0239-002	120 VAC	●		●			
7109CS-W	917-0007-002	120 VAC	●			●	●	●
7109CS-C	917-0008-002	120 VAC		●		●	●	●
7109CSX-W	917-0010-002	120 VAC	●			●	●	●
7109CSX-C	917-0011-002	120 VAC		●		●	●	●
7109LS	917-0006-002	120 VAC	●		●			●

## 713CS/LS and 7139CS/LS Series - Temporal 3 Piezo Sounder

Model Number	Part Number	Voltage	Wall Mount	Ceiling Mount	9 Foot Line Cord	Interconnect Up To 6 Units	Form C Contacts	9VDC Battery Back-Up
713CS-W	907-0248-002	120 VAC	●			●	●	
713CS-C	907-0249-002	120 VAC		●		●	●	
713CSX-W	907-0252-002	120 VAC	●			●	●	
713CSX-C	907-0253-002	120 VAC		●		●	●	
713LS	907-0256-002	120 VAC	●		●			
7139CS-W	917-0019-002	120 VAC	●			●	●	●
7139CS-C	917-0020-002	120 VAC		●		●	●	●
7139CSX-W	917-0021-002	120 VAC	●			●	●	●
7139CSX-C	917-0022-002	120 VAC		●		●	●	●
7139LS	917-0018-002	120 VAC	●		●			●

### NOTES:

Candela Rating: 177 Candela UL 1971 Listed Strobe Light  
Flash Rate per Minute: 60 Minimum

“W” = Wall Mount  
“C” = Ceiling Mount

- Available in square configuration only.
- Ceiling mount not available in line cord models.
- The X models have the ability to turn the strobe on from a field mounted relay
- When testing 713/7139 units, it may take up to 16 seconds longer for smoke alarm to go in or out of alarm mode.
- It is recommended that 710/713/7109/7139 Series smoke alarm be tested weekly.
- Refer to Technical Bulletin 002 for Easy Wash™ on site washing instructions
- 710/7109 units produce a non-temporal audible alarm and are therefore not intended for locations where the desired action of the occupant(s) is evacuation.
- 713/7139 units produce a temporal 3 audible alarm. Per NFPA 72, the American National Standard Audible Emergency Evacuation Signal as defined in ANSI S3.41, is required whenever the intended response is to evacuate the building.

# Wiring Diagram

710CS  
7109CS  
713CS  
7139CS

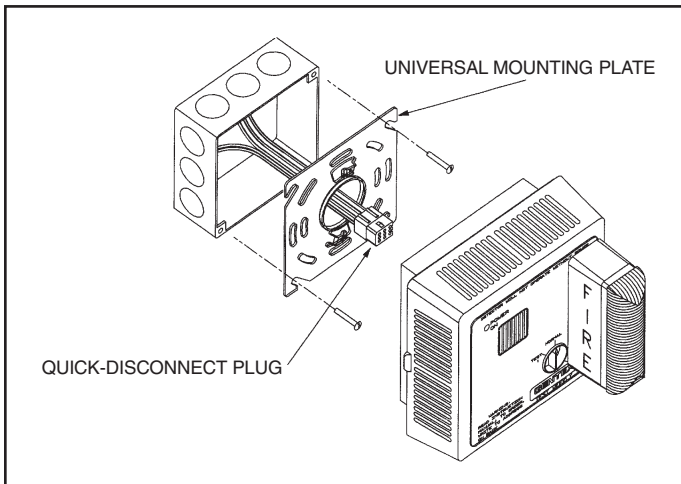
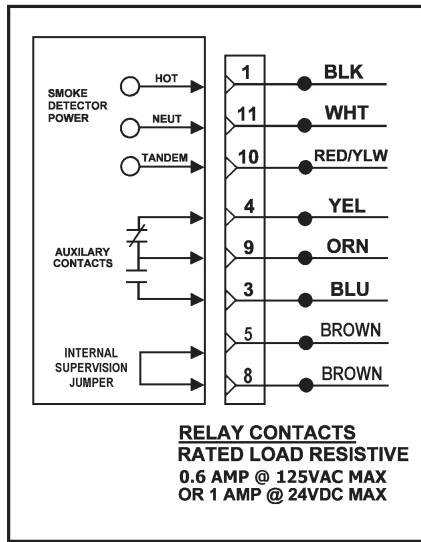

## Electrical Specifications

Operating Voltage. . . . . 120 VAC, 60Hz  
 Operating Current. . . . . 0.400 amps (Peak)  
 Operating Ambient Temp Range. . . . . 40°F to 100°F  
 Alarm Horn Rating. . . . . 90 Decibels at 10 Ft.  
 Nominal Sensitivity. . . . . 2.5% Obscuration  
 Auxiliary Relay (Standard). . . . . 1 Form C (0.6 amp)  
 (710/713CS and 7109/7139CS)  
 Size . . . . . 5.5" Square x 4.75" Overall Depth  
 Secondary Power Source. . . . . Alkaline 9VDC battery (supplied)  
 (7109CS/LS and 7139CS/LS)

The CSX models are used for remote annunciation of the strobe.

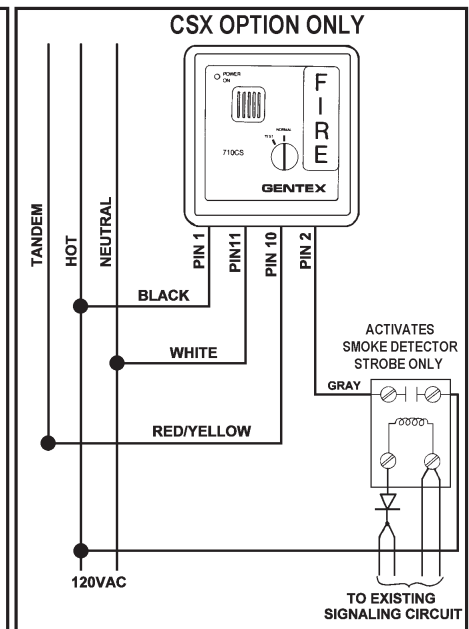
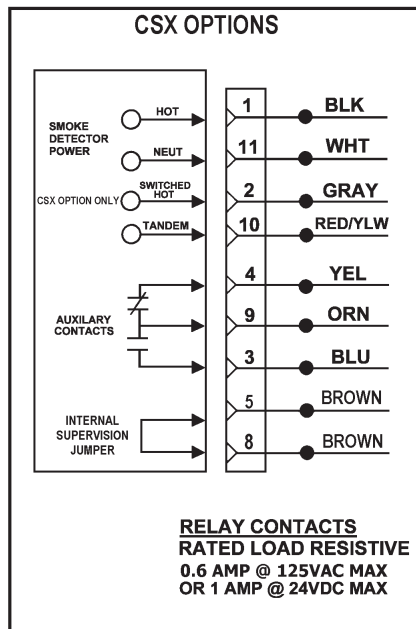

# 710/713CS/LS 7109/7139CS/ S E R I E S

## Architect & Engineering Specifications

The photoelectric smoke alarm shall be a Gentex Model 710LS, 713LS, 7109LS, 7139LS or approved equal which shall provide at least the following features and functions.

1. Nominal sensitivity shall be 2.5%.
2. The smoke alarm shall utilize an infrared LED sensing circuit which pulses in 4 to 5 second intervals; when subjected to smoke the pulse rate shall increase 8 times. After 2 consecutive pulses in smoke, the detector will alarm.
3. The smoke alarm shall provide minimum 5-to-1 signal-to-noise ratio in the optics frame to assure stability of operation in environments of high RF and transient conditions.
4. The sensing chamber shall be fully screened to prevent entrance of small insects, thus reducing the probability of false alarms.
5. A continuous piezo horn rated at 90dBA at 10 ft. (710CS/LS & 7109CS/LS units) and a temporal 3 piezo horn rated at 90dBA at 10 ft. (713CS/LS & 7139CS/LS units).
6. A visual LED monitor (condition indicator) will pulse in normal operation and steady on in alarm.
7. The visual signal shall have a minimal light output of 177 Candela.
8. An easily accessible test knob shall be provided. The test knob in the TEST position will simulate an actual smoke condition of approximately 3.5% causing the smoke alarm to alarm within 20-36 seconds. Also the alarm shall test for the most sensitive setting. An alarm during this test will be a maintenance indicator. Return to Gentex Corporation for maintenance.
9. The smoke alarm shall be provided with a 9 foot line cord with a strain relief connection, if a portable unit.
10. Unit must be capable of providing a monitored battery back-up.
11. Unit must be UL 217 and UL 1971 listed for wall mount.
12. Unit shall also meet all requirements of the State of California Fire Marshal, Bureau of Standards and Appeals and the Americans with Disabilities Act (ADA).

## Architect & Engineering Specifications

The photoelectric smoke alarm shall be a Gentex Model 710CS, 713CS, 7109CS, 7139CS or approved equal which shall provide at least the following features and functions.

1. Nominal sensitivity shall be 2.5%.
2. The smoke alarm shall utilize an infrared LED sensing circuit which pulses in 4 to 5 second intervals; when subjected to smoke the pulse rate shall increase 8 times. After 2 consecutive pulses in smoke, the smoke alarm will alarm.
3. The smoke alarm shall provide minimum 5-to-1 signal-to-noise ratio in the optics frame to assure stability of operation in environments of high RF and transient conditions.
4. The sensing chamber shall be fully screened to prevent entrance of small insects, thus reducing the probability of false alarms.
5. A continuous piezo horn rated at 90dBA at 10 ft. (710CS/LS & 7109CS/LS units) and a temporal 3 piezo horn rated at 90dBA at 10ft. (713CS/LS & 7139CS/LS units).
6. A visual LED monitor (condition indicator) will pulse in normal operation and will remain solid in alarm.
7. The visual signal shall have a minimal light output of 177 Candela and will flash one time per second.
8. An easily accessible test knob shall be provided. The test knob in the TEST position will simulate an actual smoke condition of approximately 3.5% causing the smoke alarm to alarm within 20-36 seconds. Also the detector shall test for the most sensitive setting. An alarm during this test will be a maintenance indicator. Return to Gentex Corporation for maintenance.
9. The smoke alarm shall be provided with a Form C contact for remote annunciation purposes.
10. The manufacturer shall provide other compatible detector models with the following optional features: a) auxiliary Form C relay contact for initiating remote functions and annunciation; b) relay option that is capable of activation by tandem interconnect wire.
11. Unit must be capable of providing a monitored battery back-up.
12. Unit must be UL 217 and UL 1971 listed for wall mount or ceiling mount.
13. Unit shall also meet all requirements of the State of California Fire Marshal, Bureau of Standards and Appeals and the Americans with Disabilities Act (ADA).

All equipment shall be completely factory assembled, wired and tested, and the contractor shall be prepared to submit a certified letter testifying to this condition. Detectors which do not meet all of the requirements of this specification will not be considered.

12 units per carton  
21 pounds per carton

**GENTEX**  
CORPORATION

Fire Protection Products Group • [www.gentex.com](http://www.gentex.com)  
10985 Chicago Drive • Zeeland, Michigan 49464  
616.392.7195 • 1.800.436.8391 • 616.392.4219 Fax

#### Important Notice:

These materials have been prepared by Gentex Corporation ("Gentex") for informational purposes only, are necessarily summary, and are not purported to serve as legal advice and should not be used as such. Gentex makes no representations and warranties, express or implied, that these materials are complete and accurate, up-to-date, or in compliance with all relevant local, state and federal laws, regulations and rules. The materials do not address all legal considerations as there is inevitable uncertainty regarding interpretation of laws, regulations and rules and the application of such laws, regulations and rules to particular fact patterns. Each person's activities can differently affect the obligations that exist under applicable laws, regulations or rules. Therefore, these materials should be used only for informational purposes and should not be used as a substitute for seeking professional legal advice. Gentex will not be responsible for any action or failure to act in reliance upon the information contained in this material.

551-0037-02



## 120VAC Remote Visual Signal

### Applications

The GXS-120 Series is a high quality remote visual signaling appliance that offers dependable remote annunciation. The GXS-120 is ideal for applications where a dependable visual alarm is required in applications such as hotels, dormitories and apartments.

The GXS-120 Series has a constant flash rate of 1Hz. The GXS-120 Series is provided with a two position terminal block (12-18AWG).

The GXS-120 has a 177 candela strobe that meet the requirements of the ADA. GXS-120 appliances are ANSI/UL 1971 listed and are warranted for three years from the date of purchase.

### Standard Features

- Nominal voltage 120VAC
- 177 candela strobe meets the requirements of NFPA 72 and meets the requirements of ADA
- Unit Dimensions: 4.5" high x 4.56" wide x 2.25" deep
- Terminal blocks (12-18 AWG)
- Flash rate 1Hz
- Wide variety of mounting options for new construction and retrofit applications
- ANSI/UL 1971 listed for fire protective service/signal for hearing impaired
- Faceplate available in red or off-white

GXS-120 Series Remote Strobe		
Model Number	Part Number	Candela (ANSI/UL 1971)
GXS-120177WR	904-0780-002	177
GXS-120177WW	904-0758-002	177
GXS-120177CR	904-0781-002	177
GXS-120177CW	904-0759-002	177

GXS-120 Series Strobe Current Ratings	
Candela	177cd
UL Max	209mA

### NOTES:

Operating temperature: 32° to 120°F (0° to 49°C)  
 GXS-120 Series is **not** listed for outdoor use

"W" = Wall mount      "C" = Ceiling mount  
 "R" = Red faceplate    "W" = Off-White faceplate  
 "P" = Plain (no lettering)

The plain "P" units are non-returnable.

## G X S - 1 2 0 S E R I E S



### Product Listings

#### SIGNALING



LISTED



- ANSI/UL 1971
- CSFM Listing 7125-569:114
- MEA #285-91-E
- BFP (City of Chicago)

### Product Compliance

- Americans with Disabilities Act (ADA)
- NFPA 72
- IBC/IFC/IRC
- Quality Management System is certified to: ISO 9001:2008



# GXS-120 SERIES

## Mounting Rough-in Box and Run Wiring

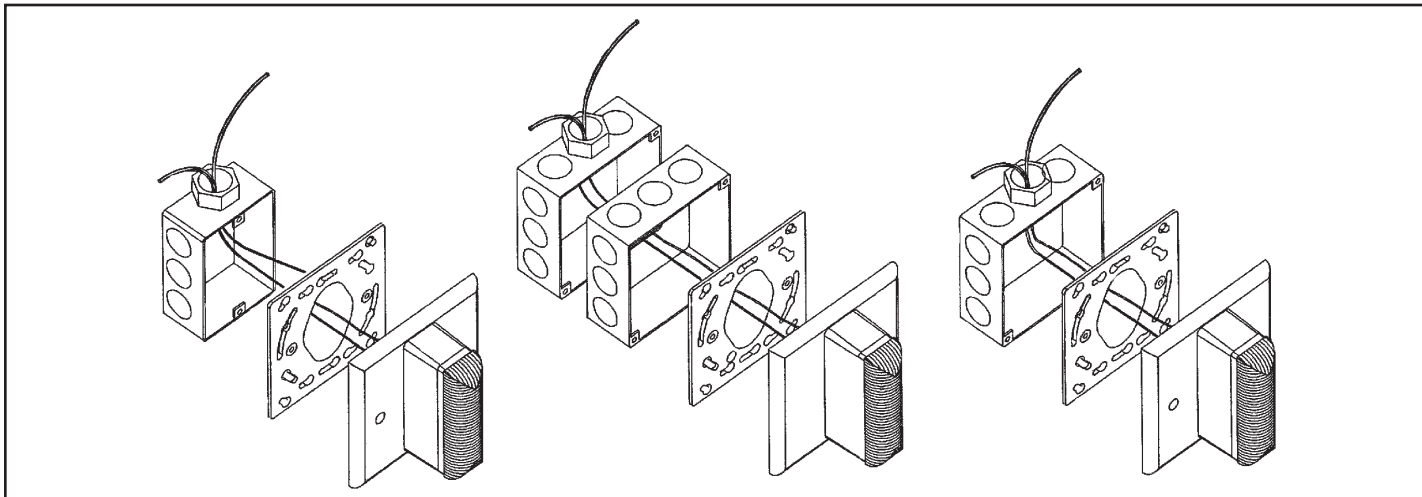

## Wiring Diagram GXS-120

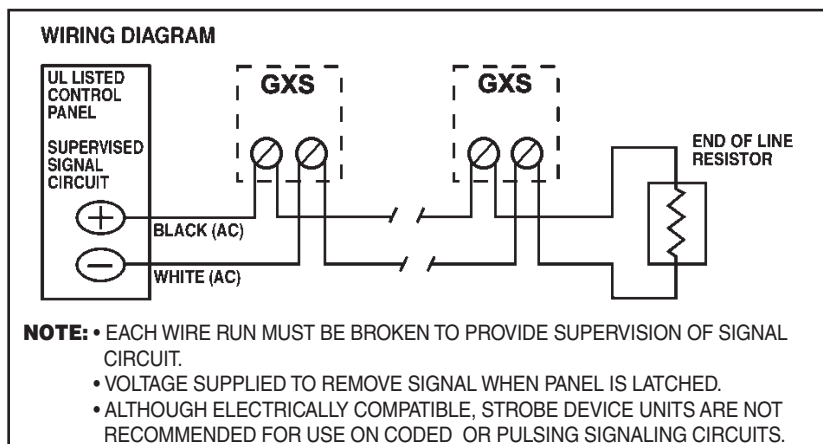

## Architect & Engineering Specifications

The visual signal shall be the Gentex Model GXS-120 or approved equal. The visual appliance shall be ANSI/UL 1971 listed by Underwriters Laboratories.

The visual appliance shall be installed in accordance with the appropriate provisions of the National Fire Protection Association, American National Standards or other applicable state and local requirements.

The visual signal shall be capable of mounting to a single gang, double gang, double work box or 4" square back box. The visual signal shall have a constant flash rate of 1Hz regardless of listed input voltage.

24 units per carton  
12 pounds per carton

# GENTEX CORPORATION

Fire Protection Products Group • [www.gentex.com](http://www.gentex.com)  
10985 Chicago Drive • Zeeland, Michigan 49464  
616.392.7195 • 1.800.436.8391 • 616.392.4219 Fax

Gentex Corporation reserves the right to make changes to the product data sheet at their discretion.

### Important Notice:

These materials have been prepared by Gentex Corporation ("Gentex") for informational purposes only, are necessarily summary, and are not purporting to serve as legal advice and should not be used as such. Gentex makes no representations and warranties, express or implied, that these materials are complete and accurate, up-to-date, or in compliance with all relevant local, state and federal laws, regulations and rules. The materials do not address all legal considerations as there is inevitable uncertainty regarding interpretation of laws, regulations and rules and the application of such laws, regulations and rules to particular fact patterns. Each person's activities can differently affect the obligations that exist under applicable laws, regulations or rules. Therefore, these materials should be used only for informational purposes and should not be used as a substitute for seeking professional legal advice. Gentex will not be responsible for any action or failure to act in reliance upon the information contained in this material.

551-0036-03