

DISPLAY THIS CARD ON PRINCIPAL FRONTAGE OF WORK



CITY OF PORTLAND BUILDING PERMIT

This is to certify that LMG PROPERTIES

Located At 255 OXFORD ST

Job ID: 2012-05-4056-ALTR

CBL: 033-D-020-001

has permission to Replace 2 steps at 255 Oxford (right side), and repair all other sets of steps at 257 thru 259 provided that the person or persons, firm or corporation accepting this permit shall comply with all of the provisions of the Statutes of Maine and of the Ordinances of the City of Portland regulating the construction, maintenance and use of the buildings and structures, and of the application on file in the department.

Notification of inspection and written permission procured before this building or part thereof is lathed or otherwise closed-in. 48 HOUR NOTICE IS REQUIRED.

A final inspection must be completed by owner before this building or part thereof is occupied. If a certificate of occupancy is required, it must be

Fire Prevention Officer

Code Enforcement Officer / Plan Reviewer

6/20/12

THIS CARD MUST BE POSTED ON THE STREET SIDE OF THE PROPERTY
PENALTY FOR REMOVING THIS CARD

BUILDING PERMIT INSPECTION PROCEDURES

Please call 874-8703 or 874-8693 (ONLY)

or email: buildinginspections@portlandmaine.gov

With the issuance of this permit, the owner, builder or their designee is required to provide adequate notice to the city of Portland Inspections Services for the following inspections. Appointments must be requested 48 to 72 hours in advance of the required inspection. The inspection date will need to be confirmed by this office.

- **Please read the conditions of approval that is attached to this permit!! Contact this office if you have any questions.**
- **Permits expire in 6 months. If the project is not started or ceases for 6 months.**
- **If the inspection requirements are not followed as stated below additional fees may be incurred due to the issuance of a "Stop Work Order" and subsequent release to continue.**

Footings/Setbacks prior to pouring concrete (Installed after the fact)

Final Inspection

The project cannot move to the next phase prior to the required inspection and approval to continue, REGARDLESS OF THE NOTICE OF CIRCUMSTANCES.

IF THE PERMIT REQUIRES A CERTIFICATE OF OCCUPANCY, IT MUST BE PAID FOR AND ISSUED TO THE OWNER OR DESIGNEE BEFORE THE SPACE MAY BE OCCUPIED.



PORTLAND MAINE

Strengthening a Remarkable City, Building a Community for Life • www.portlandmaine.gov

Acting Director of Planning and Urban Development
Gregory Mitchell

Job ID: 2012-05-4056-ALTR

Located At: 255 OXFORD ST

CBL: 033- D-020-001

Conditions of Approval:

Zoning

1. This permit is being approved on the basis of plans submitted. Any deviations shall require a separate approval before starting that work.
2. This property shall remain a total 15 residential dwelling units in several attached buildings. Any change of use shall require a separate permit application for review and approval.

Fire

1. Installation shall comply with City Code Chapter 10.
2. All construction shall comply with City Code Chapter 10.
3. <http://www.portlandmaine.gov/citycode/chapter010.pdf>

Building

1. Application approval based upon information provided by the applicant or design professional. Any deviation from approved plans requires separate review and approval prior to work.
2. Permit approved based on the plans submitted and reviewed w/owner/ contractor, with additional information as agreed on and as noted on plans; including the following:
 - Rise and run to meet IBC code 7/11 with no nosing projection
 - Brackets installed at the post to sono tube
 - Graspable handrails to be installed both sides, 34"- 38" with returns
3. Separate permits are required for any electrical, plumbing, sprinkler, fire alarm, HVAC systems, heating appliances, including pellet/wood stoves, commercial hood exhaust systems and fuel tanks. Separate plans may need to be submitted for approval as a part of this process.



General Building Permit Application

Entered 5/22/12

(B)

If you or the property owner owes real estate or personal property taxes or user charges on any property within the City, payment arrangements must be made before permits of any kind are accepted.

A 2012 - 05 - 4056 - ALTR 5-2b

Location/Address of Construction: <u>255 OXFORD STREET PORTLAND, ME, 04102</u>		
Total Square Footage of Proposed Structure/Area	Square Footage of Lot	Number of Stories <u>2</u>
Tax Assessor's Chart, Block & Lot Chart# Block# Lot# <u>33-D-20; 21</u>	Applicant * <u>must</u> be owner, Lessee or Buyer* Name <u>LMG PROPERTIES</u> Address <u>470 FOREST AVE.</u> City, State & Zip <u>PORTLAND, ME 04102</u>	Telephone: <u>(207)-347-1909</u>
Lessee/DBA (If Applicable) RECEIVED MAY 22 2012 Dept. of Building Inspections City of Portland Maine	Owner (if different from Applicant) Name Address City, State & Zip	Cost Of <u>2008</u> Work: \$ <u>1300.00</u> C of O Fee: \$ _____ Total Fee: \$ <u>40.00</u>
Current legal use (i.e. single family) <u>Apt. Building</u> Number of Residential Units <u>2</u> If vacant, what was the previous use? <u>NOT VACANT</u> Proposed Specific use: <u>RENTAL PROPERTY</u> Is property part of a subdivision? <u>NO</u> If yes, please name <u>N/A</u> Project description: <u>STEPS TO ENTRY</u>		
Contractor's name: <u>Adam Flaherty Jr.</u> Address: <u>106 SHERRADAN STREET</u> City, State & Zip <u>PORTLAND ME, 04101</u> Telephone: <u>207-347-1909</u> Who should we contact when the permit is ready: <u>ADAM FLAHERTY</u> Telephone: <u>207-347-1909</u> Mailing address: <u>SAME</u>		

Please submit all of the information outlined on the applicable Checklist. Failure to do so will result in the automatic denial of your permit.

In order to be sure the City fully understands the full scope of the project, the Planning and Development Department may request additional information prior to the issuance of a permit. For further information or to download copies of this form and other applications visit the Inspections Division on-line at www.portlandmaine.gov, or stop by the Inspections Division office, room 315 City Hall or call 874-8703.

I hereby certify that I am the Owner of record of the named property, or that the owner of record authorizes the proposed work and that I have been authorized by the owner to make this application as his/her authorized agent. I agree to conform to all applicable laws of this jurisdiction. In addition, if a permit for work described in this application is issued, I certify that the Code Official's authorized representative shall have the authority to enter all areas covered by this permit at any reasonable hour to enforce the provisions of the codes applicable to this permit.

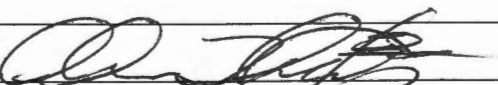
Signature:  Date: 05-18-12

This is not a permit; you may not commence ANY work until the permit is issued



PORTLAND MAINE

Strengthening a Remarkable City, Building a Community for Life • www.portlandmaine.gov

Receipts Details:

Tender Information: Cash
Tender Amount: 40.00

Receipt Header:

Cashier Id: bsaucier
Receipt Date: 5/22/2012
Receipt Number: 44180

Receipt Details:

Referance ID:	6613	Fee Type:	BP-Constr
Receipt Number:	0	Payment Date:	
Transaction Amount:	40.00	Charge Amount:	40.00
Job ID: Job ID: 2012-05-4056-ALTR - Updating steps			
Additional Comments: 255 Oxford St.			

Thank You for your Payment!

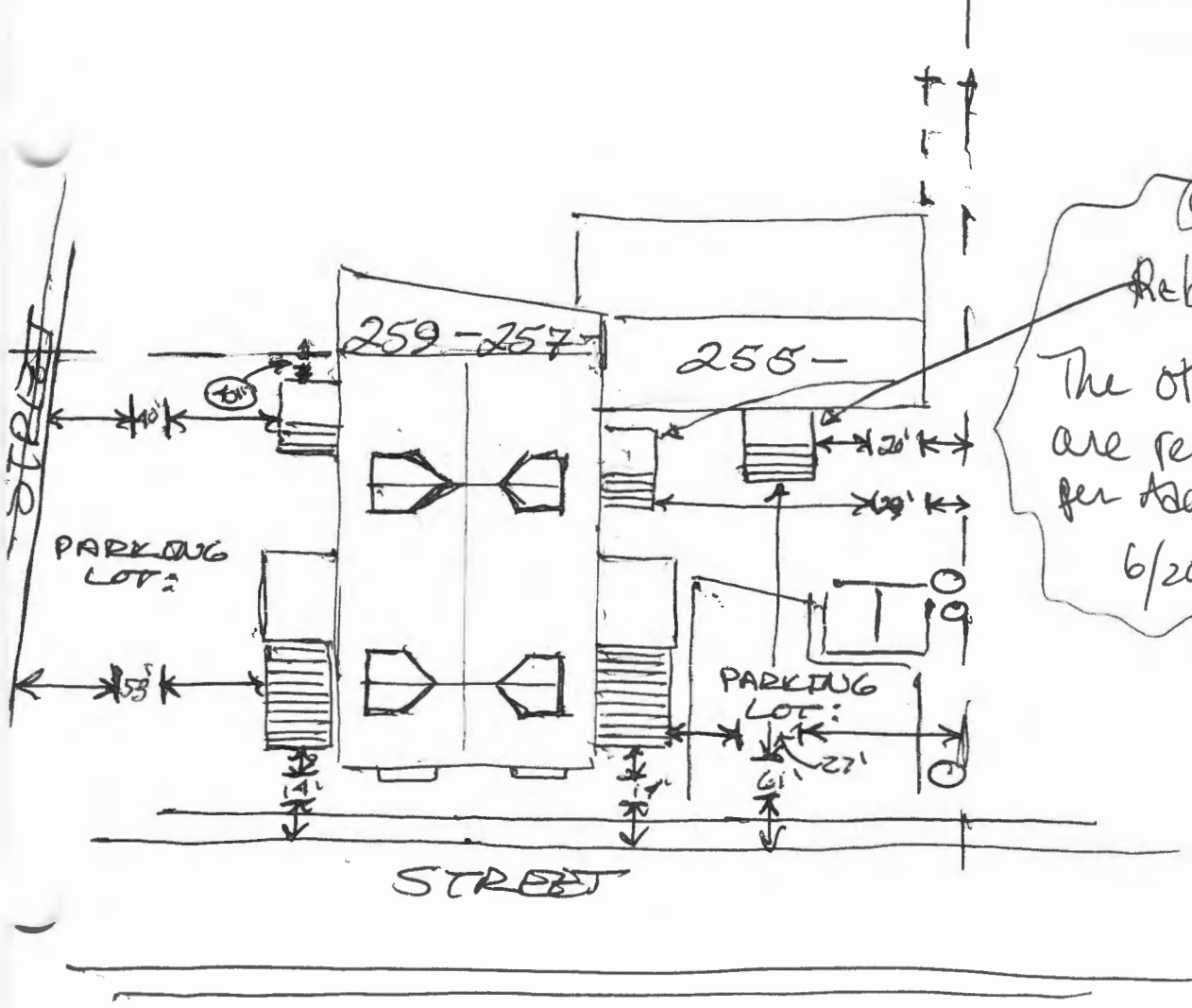

Rebuilt
 The others
 are repaired
 per Adam F
 6/20/12

RAILINGS SET
@ 46" HIGH.

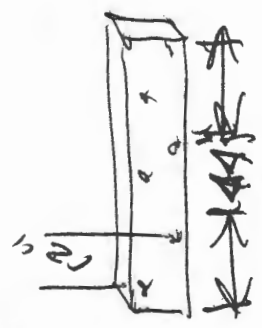
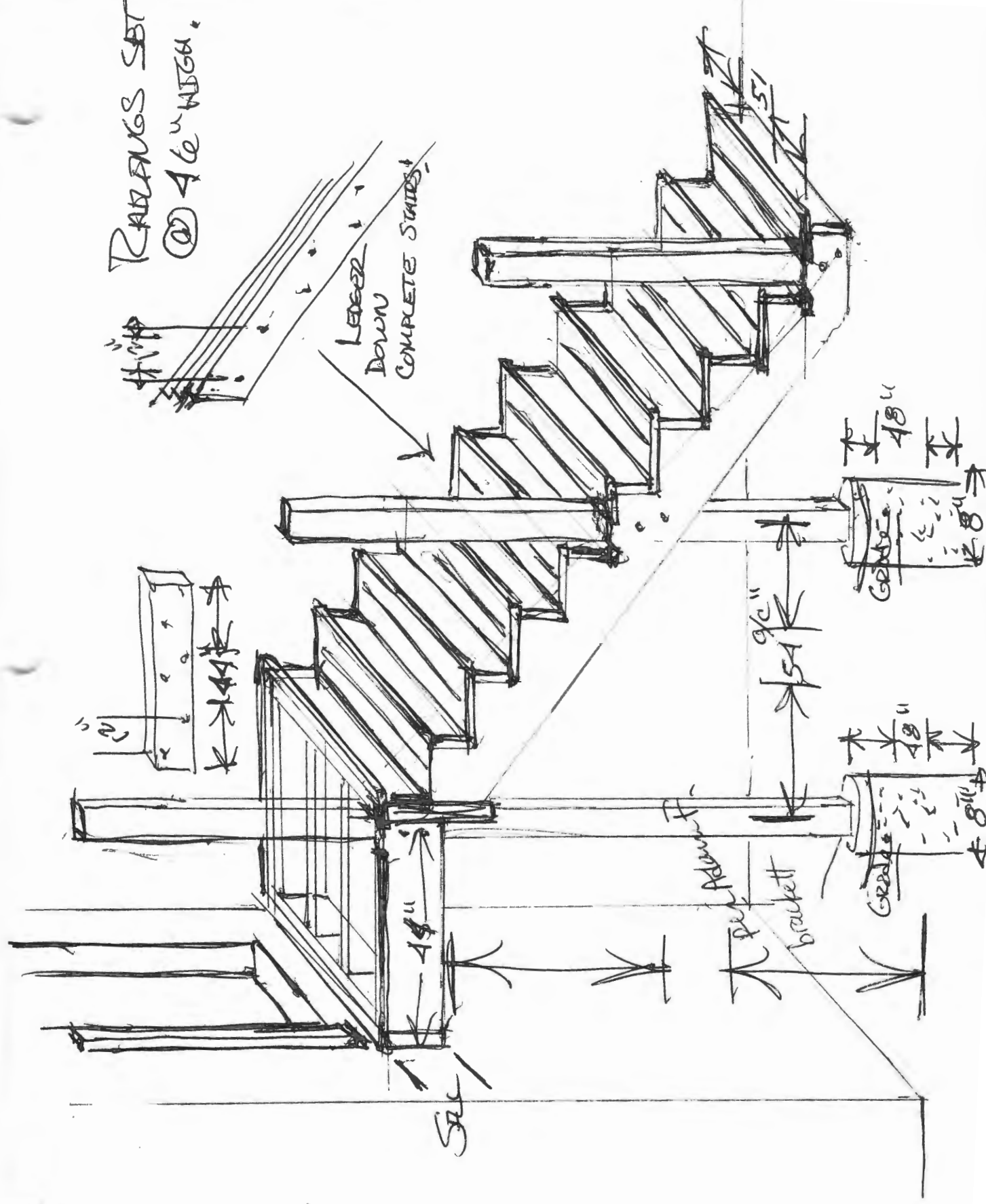
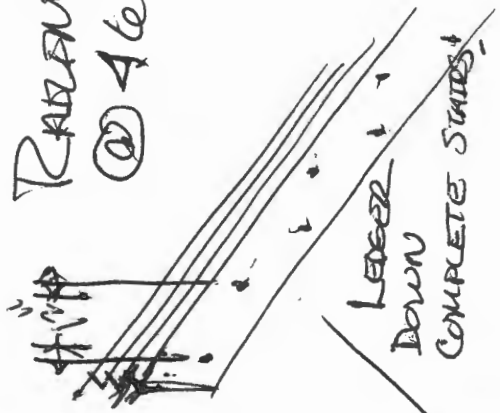

48"

154"

96"

48"

48"

SEC

PULL DOWN
bracket

GRAB

LEADER
DOWN
COMPLETE STAIRS!

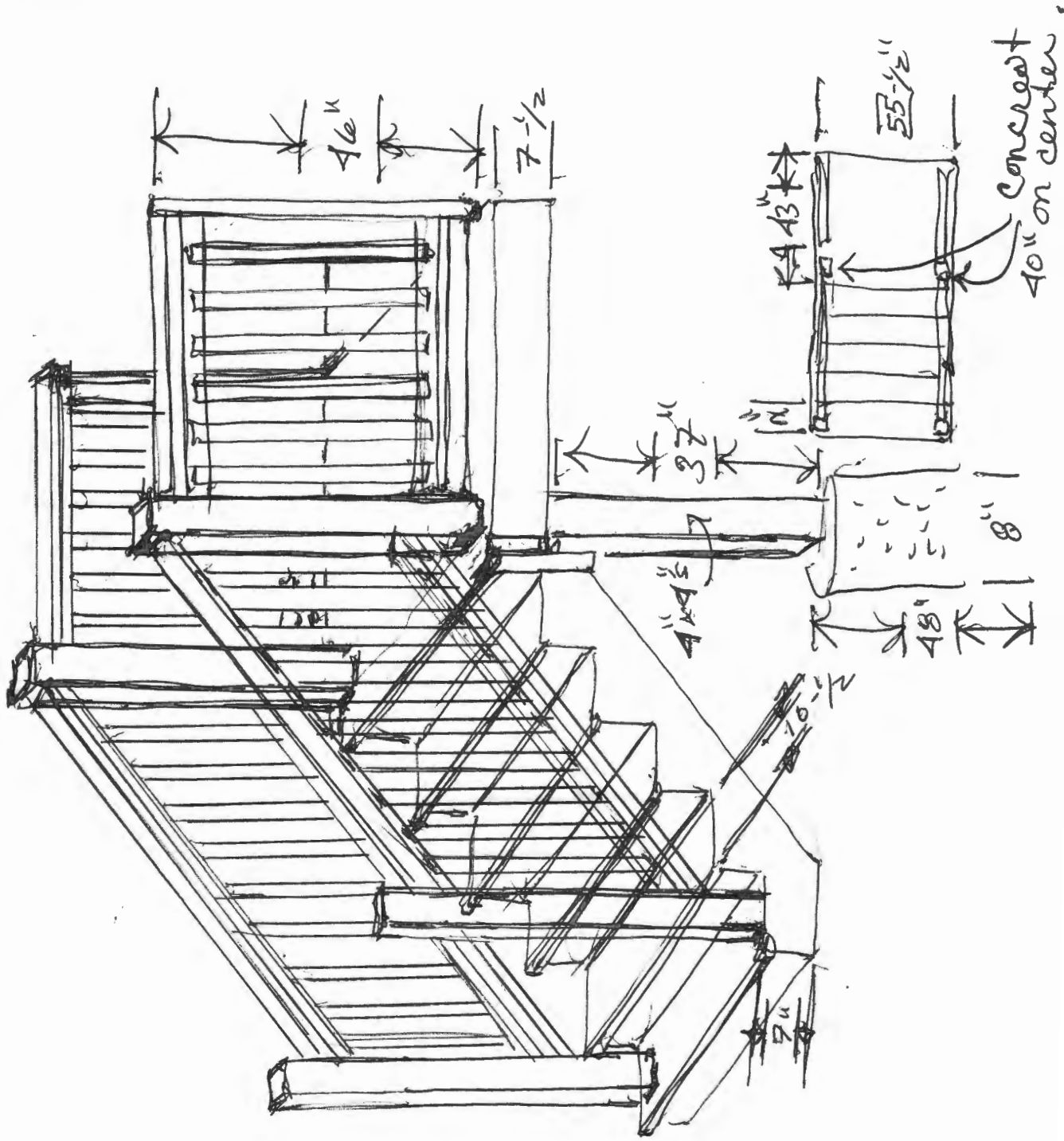

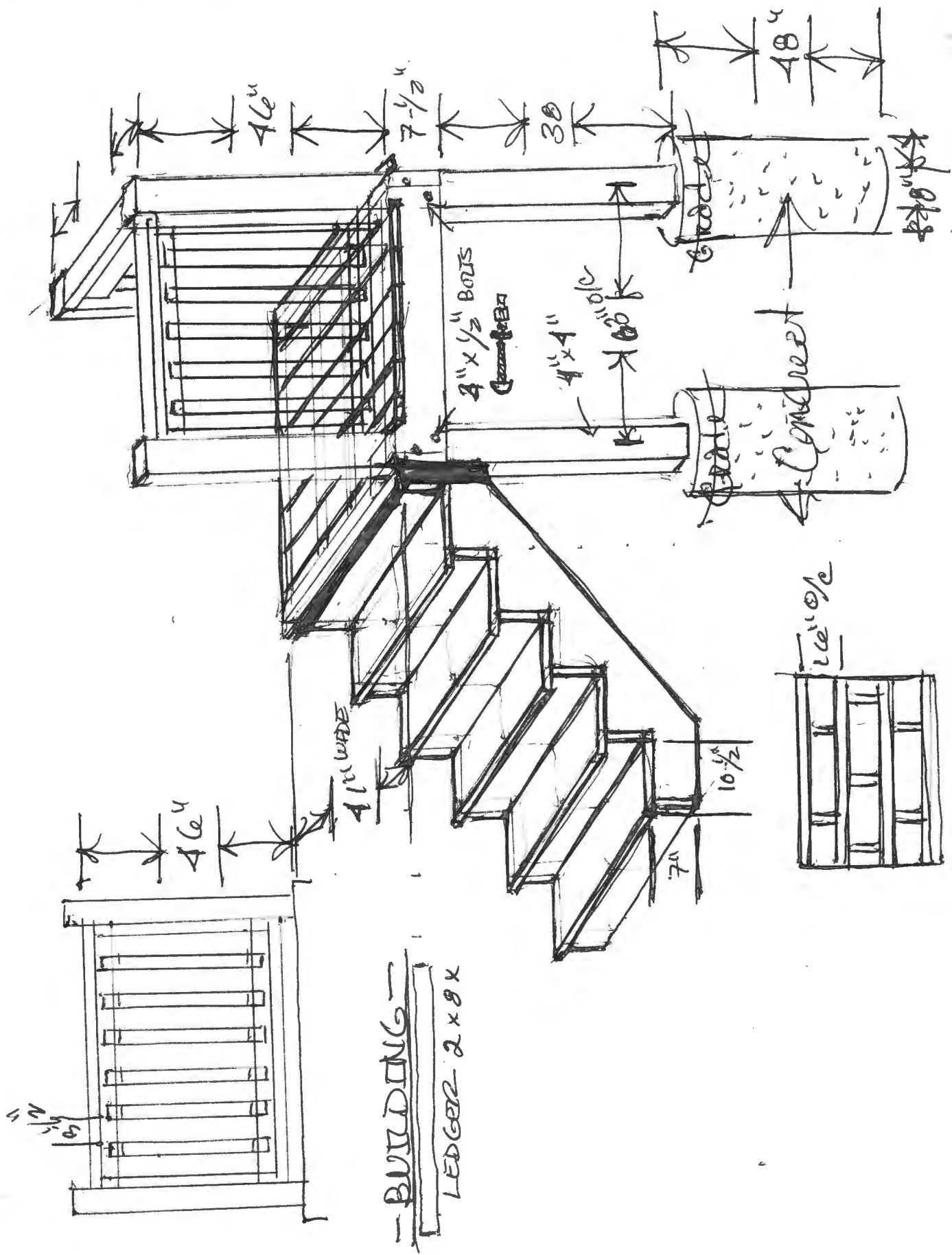

255 - OXFORD STREET;

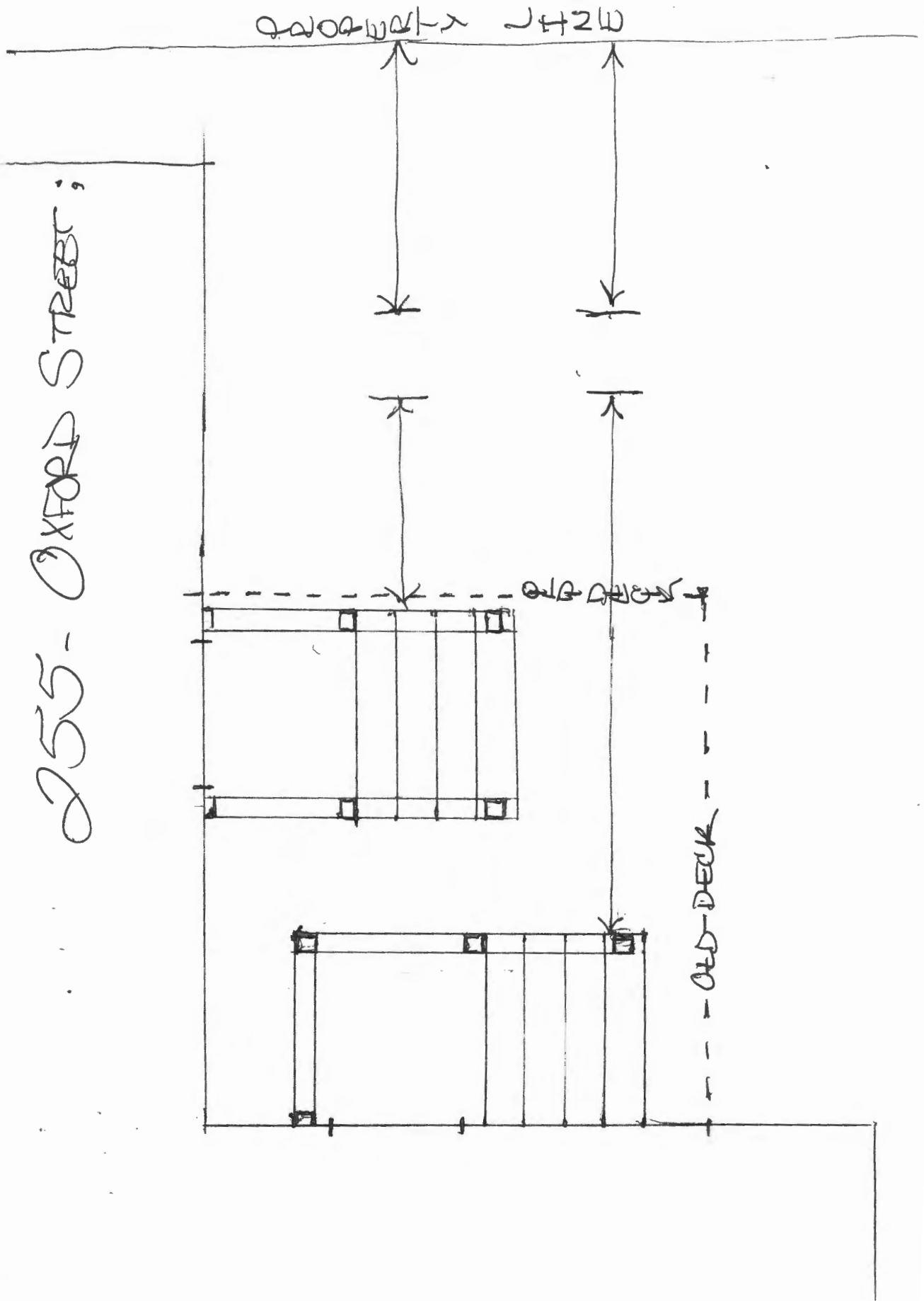

255 OXFORD STREET

