



Please fax this information to the Administrative Sales Assistant at the So. Portland Office at (207)-879-0540.

Building Owner Information Form

Job Name:	Project #:
------------------	-------------------

Electrical Contractor:

NFPA requires this information for proper documentation

****The contractor MUST provide all of the information with an asterisk below before ANY equipment can be released.***

If building owner contact is unknown provide contact name/tel. of GC and check box

Electrical Contractor Contact Name:
--

Estimated Date Equip. Needed:	*Estimated Finals Date:
--------------------------------------	--------------------------------

*Building Owner:

*Job Site Address:

*City:	State:	Zip:
---------------	---------------	-------------

*Contact Name: _____ <input type="checkbox"/> Check here if GC

*Phone #:	Fax #:
------------------	---------------



Norris Inc.

PO Box 2551
2257 West Broadway
South Portland, ME 04106

1.800.370.3473
fax 207.879.0540

www.norrisinc.com

Thank you for your cooperation.

Please advise the building owners that if this system is equipped with a digital communicator, then they MUST also make monitoring arrangements prior to a certificate of occupancy. Norris Inc. will attempt to contact the building owners



STOP!

**THIS COPY IS FOR YOUR ELECTRICIAN
ON THE JOB-SITE**

PLEASE BE SURE THIS COPY IS FORWARDED

- 1) **A riser diagram is enclosed. DO NOT USE THE ENGINEER'S RISER SHOWN ON THE PLANS. If there is any information that you question, call us immediately.**
 - 2) **YOU MUST CALL AT LEAST FIVE DAYS IN ADVANCE TO SCHEDULE FINAL CONNECTION ASSISTANCE.**
 - 3) **All of your wires must be labeled and clear of any grounds, shorts or opens and must maintain polarity throughout. Meter out all circuits before calling for final connection assistance. If applicable verify End of Line resistors are in place.**
 - 4) **If using shielded cable, the drain wires must be connected and fully insulated (wrapped with tape) so that neither the shield or the drain wire touches the backbox.**
 - 5) **Unless special arrangements are made, we will make one final job-site visit. If a special visit is required for an elevator inspection or partial occupancy, then additional charges may apply if special arrangements were not made ahead. Call your customer service representative.**
 - 6) **If you have any defective or left-over parts DO NOT WRITE ON THEM OR THE BOXES. Save the original box, all mounting hardware and instructions. Returns that do not conform to this practice will not be accepted for credit.**
 - 7) **If the system is being monitored through a digital communicator, then please turn to page 2.**
-



Norris Inc.

PO Box 2551
2257 West Broadway
South Portland, ME 04106

1.800.370.3473
fax 207.879.0540

www.norrisinc.com

IMPORTANT INFORMATION FOR THE BUILDING OWNERS SPECIAL NOTE REGARDING ALARM MONITORING SERVICES

Included within your alarm system package is a digital communicator, which sends a coded message to a private 24-hour central station if your alarm system is activated. This is a code requirement for most fire alarm systems. As a service to our customer, we offer central station monitoring services from our local UL Listed central station at extremely competitive rates.

If the central station monitoring contract is purchased through Norris Inc. prior to our scheduled start-up; we will connect, program, and test the communicator at no additional charge.

Should the building owners decide to obtain monitoring services from another company, then the cost for programming and testing the communicator will be the sole responsibility of the firm they have contracted with. Furthermore, if programming changes are made to the system by persons other than Norris Inc. technicians, then the company performing the changes shall be solely liable for any personal injury or loss of life or damage to or loss of property arising out of the use of or inability to use the system and it shall result in a waiver of any system warranties.

We appreciate that you understand the delicate nature of this life safety and/or security system and realize that serious problems may arise when modifications to the system are made including very simple programming changes.

**Call Norris Inc. at 1-800-370-FIRE (3473) to make
arrangements for central station monitoring services.**



Norris Inc.

PO Box 2551
2257 West Broadway
South Portland, ME 04106

1.800.370.3473
fax 207.879.0540

www.norrisinc.com

SUBMITTAL PACKAGE

Project: Salvation Army Adult Rehab Center

System: Fire Alarm Addition

**Submitted By: Norris Inc.
2257 West Broadway
South Portland, Maine 04106
Telephone: (800) 370-3473**

Date: May 22nd, 2017



Company Profile

"We are extremely proud to represent the highest quality manufacturers integrating life safety, alarm and communication systems throughout northern New England."

-- Bradford Norris, President --

Mission Statement

Provide quality engineered systems, exceptional service.

Goal

Learn...Continually Improve...Exceed Expectations

Founded in 1979 Norris Inc. has grown to become Northern New England's leading integrated system contracting and supply company. Norris Inc. is an innovated proactive organization with extensive experience in integration interdisciplinary building management systems. Our local and national affiliations assure that your project will be done properly regardless of size representing leading manufacturers our comprehensive products provide outstanding quality reliability and performance... surpassing customer application requirements and exceeding the stringent requirements of Underwriters Laboratories, National Fire Protection Association and other codes. We maintain an exceptional level of quality and provide the highest levels of customer service. Our knowledgeable technical support will insure the great service you deserve. Whether your needs involve industrial, commercial, institutional, or educational applications, you can trust that Norris Inc. has the complete resources it takes to provide the right solution right away.



This is to certify that

NORRIS, INC.

is an authorized Engineered Systems Distributor for NOTIFIER

During the years of 2015-2016



Signed for and on behalf of NOTIFIER

Vice President Global Sales



Norris Inc.

PO Box 2551
2257 West Broadway
South Portland, ME 04106

1.800.370.3473
fax 207.879.0540

www.norrisinc.com

LIMITED WARRANTY

Norris, Inc. warrants that the products of its manufacturers shall be free from defects in materials or workmanship as warranted by the manufacturer which is typically for a one (1) year period from the completed installation date, but not always. The completed installation date will be the date when the end-user was able to begin using or started using the product(s) or the system, whether partially or in its entirety. For projects that have a specification or bid instructions to follow which contains specific warranty requirements, Norris Inc. will always honor the warranty terms exactly as specified in the project's specifications or bid documents, which may be more or less in coverage and duration than the manufacturer's warranty. In performing hundreds of projects per year with thousands of different products it is impossible for Norris, Inc. to track the terms and details of specified or individual product warranties. Therefore Norris, Inc. will request that the owner's representative provide these special warranty details when the warranty work is requested; otherwise a standard one year warranty on the equipment will be honored. The manufacturer's warranty is for equipment only and does not include any labor and/or shipping costs. All warranties provided by Norris, Inc. are limited with the same limitations included with the manufacturer's warranty which is included in the manuals of the products being provided.

The warranty will apply only if such goods have been properly installed, are subject to normal proper use and have not been modified in any manner whatsoever. Upon return of the defective product, Norris, Inc. will, at its sole discretion, either repair or replace, at no cost, such goods determined to have a defect in materials or workmanship. In cases of a warranty repair, Norris, Inc. will use its sole discretion to determine if a suitable replacement part can be provided on loan while the repairs are being performed.

All warranty work is performed during regular business hours. If emergency warranty work is required, the customer will pay the difference between the emergency service bill and our normal hourly charges.

Norris, Inc.'s limited warranty does not apply to those products that are damaged due to misuse, abuse, negligence, exposure to adverse environmental conditions, acts of God or have been modified in any manner whatsoever.

Norris, Inc.'s Standard terms and conditions are provided with our invoices. Those Terms and Conditions shall be provided upon request.

NORRIS, INC. SHALL NOT UNDER ANY CIRCUMSTANCES BE LIABLE FOR ANY INCIDENTAL OR CONSEQUENTIAL DAMAGES ARISING FROM LOSS OF LIFE &/OR PROPERTY OR OTHER DAMAGE OR LOSSES OWING TO THE FAILURE OF NORRIS INC. PRODUCTS BEYOND THE COST OF REPAIR OR REPLACEMENT OF ANY DEFECTIVE PRODUCTS.

NORRIS, INC. MAKES NO WARRANTY OF FITNESS OR MERCHANTABILITY AND NO OTHER WARRANTY, ORAL OR WRITTEN, EXPRESS OR IMPLIED AS ALLOWED TO THE FULLEST EXTENT OF THE LAW.



Norris Inc.

PO Box 2551
2257 West Broadway
South Portland, ME 04106

1.800.370.3473
fax 207.879.0540

www.norrisinc.com

OUR CONTINUOUS COMMITMENT TO OUR ENVIRONMENT

At Norris, Inc. we are proudly committed to continuous environmental improvement for a sustainable future and to develop strong partnerships within our community.

Our mission while running our operations is to do everything within our power to improve the environmental quality of our world and to work together to create a clean and safe place to live in and work in for future generations.

We will incorporate and promote green practices within our operations with policies to support it, a system of rewarding those that fully embrace it and then will regularly review our practices for continuous improvement.

We will establish policies, make investments in technologies and set the example in our own operations to include our ongoing commitment to go paperless and making it a requirement to Reuse, Reduce & Recycle, to turn off unneeded lights, to not allow our vehicles to idle, to encourage carpooling and to utilize practical energy efficient transportation.

We will always be 100% compliant with all applicable environmental laws and regulations and will report any violations.

We will remain committed to working locally and whenever possible to sell and use locally manufactured products.

We will insist that every purchase we make will include a review of its environmental impact with a very high priority to selecting the greenest products and services available.

We will remain committed to selling low energy products. This includes promoting wireless technologies, using existing wire infrastructures in our installations, promoting solar powered devices, using our Remote Services in lieu of on-site service calls and performing calculations to minimize power supply and battery needs.

We will educate our employees and customers to illustrate that green practices and purchases are almost always less costly in the long run.

We will support and give priority to organizations that show the strongest commitment to the environment.

We will actively encourage and promote the same responsible green practices that we utilize in the work place to our employees for use in their everyday personal lives.



Norris Inc.

PO Box 2551
2257 West Broadway
South Portland, ME 04106

1.800.370.3473
fax 207.879.0540

www.norrisinc.com

REMOTE INTERNET CONNECTIONS

As an added service to our customers and in order to facilitate the commissioning of the system(s) being provided within this submittal and then later provide warranty support Norris, Inc. may (at Norris, Inc.'s option) use internet connections to gain access to the system(s) being provided. Many methods can be used, but the most popular is utilizing software named LogMeln. This software or any other method used to connect to the customer's network will allow Norris, Inc.'s technicians the ability to get onto the programming and diagnostic levels of the system(s) being provided via the building owner's or tenant's data network and program, diagnose or make needed changes to the operation of the system(s). This will provide a better working atmosphere to perform programming from a controlled environment without the disruptions of a construction job-site and will allow fast and efficient troubleshooting and/or servicing if problems should occur later. Acceptance of this submittal by those approving it shall constitute an acceptance and approval to perform the work necessary to install and/or enable these network connections if Norris, Inc. chooses to do so. It is the sole responsibility of the submittal approvers to advise the building owners and/or tenants that Norris, Inc. has the ability to gain access to their network. At the specific request of those approving this submittal or the contractor that Norris, Inc. is working for or the building owners or tenants that own the network, Norris, Inc. can remove or disable the ability to connect to the building's network. However, leaving it in place will allow for quicker and more cost effective service when it is needed. Under absolutely no circumstances shall Norris, Inc., its principals, employees or heirs be held responsible for any losses incurred as a result of this network connection or the inability for the network connection to operate as expected.

Norris Inc

2257 West Broadway

South Portland, ME 04106

1-800-370-3473

REGIONAL ELECTRIC LLC

186 SUMMER STREET

AUBURN, ME 04210

TEL: 207-795-7800

325152SP**Equipment List****Salvation Army ARC, Portland****Description**

FL-SD355, Addressable Photoelectric Smoke Detector

FL-BG12LX, Addressable Pull Station

FL-D355PL, Addressable Duct Detector

FL-ST3, Sampling Tube

SS-RTS151, Remote Test Station

FL-CRF300, Addressable Relay MMF300, Addressable Monitor Module

FL-FCPS24FS8, Remote Power Supply

IM-1270, 12V 7AH Battery

NOTIFIER-P2R, Horn Strobe, Wall, Red

NOTIFIER-SR, Strobe,Wall, Red

GENTEX-GN-303, 120VAC/9VDC Sng/Mult.Alarm, Temporal 3 Aud. Sng.

GENTEX-GN-503F, 120VAC/9VDC Sng/Mult.SmK/COAlarm Un/mntTemp Sng.,

AES, AES Radio Masterbox

AES-7788F, UL Fire 8 ZoneEK-TRG1640, 16.5VAC, 45VA Transformer

AES-7210-5-UM, 5dB Omni directional UHF Antenna

AES-13-0346, Cable Assembly; 18# RG-58 Used to connect RG-8

SPAAGEELE-VS000091, AES Radio Disconnect Enclosure

GI-TSW01S, Box Tamper

AES-7230, Standard Coaxial Surge Protector, N female N female

NOTIFIER-R-20T, Relay DPDT

SD355(A) Series

Addressable Photoelectric Smoke Detectors



Addressable Devices

General

The **SD355(A)**, **SD355T(A)**, and **SD355R(A)** addressable, low-profile plug-in photoelectric detectors use a state-of-the-art photoelectric sensing chamber with communications to provide open area protection and are used exclusively with Fire•Lite's Addressable Fire Alarm Control Panels (FACPs). The **SD355T(A)** adds thermal sensors that will alarm at a fixed temperature of 135°F (57°C). Since these detectors are addressable, they will help emergency personnel quickly locate a fire during its early stages, potentially saving precious rescue time while also reducing property damage. Two LEDs on each sensor light to provide a local, visible sensor indication. Remote LED annunciator capability is available as an optional accessory, PN RA100Z(A). The **SD355R(A)** is a remote test capable detector for use with D355PL(A) or DNR(A)/DNRW duct smoke detector housings.

Features

SLC loop

- Two-wire loop connection.
- Unit uses base for wiring.

Addressing

- Addressable by device.
- Rotary, decimal addressing: 01 – 99 with MS-9200 series, and 01 – 159 with MS-9600 series.

Architecture

- Unique single-source, dual-chamber design to respond quickly and dependably to a broad range of fires.
- Sleek, low-profile design.
- Integral communications and built-in type identification.
- Built-in tamper-resistant feature.
- Removable cover and insect-resistant screen for simple field cleaning.

Operation

- Withstands air velocities up to 4,000 feet-per-minute (20 m/sec.) without triggering a false alarm.
- Factory preset at 1.5% nominal sensitivity for panel alarm threshold level.
- Visible LED “blinks” when the unit is addressed (communicating with the fire panel) and latches on in alarm.

Mechanicals

- Sealed against back pressure.
- Direct surface mounting or electrical box mounting.
- Mounts to: single-gang box, 3.5" (8.89 cm) or 4.0" (10.16 cm) octagonal box, or 4.0" (10.16 cm) square electrical box (*using a plaster ring — included*).

Other system features

- Fully coated circuit boards and superior RF/transient protection.
- 94-V0 plastic flammability rating.
- Low standby current.

Options

- Remote LED output connection, PN RA100Z(A).



SD355(A) in B210LP(A) Base

B210-2851.jpg

Applications

Use photoelectric detectors in life-safety applications to provide a broad range of fire-sensing capability, especially where smoldering fires are anticipated. Ionization detectors are often better than photoelectric detectors at sensing fast, flaming fires.

Construction

These detectors are constructed of off-white fire resistant plastic. SD355(A) series plug-in, low-profile smoke detectors are designed to commercial standards and offer an attractive appearance.

Installation

SD355(A) series plug-in detectors use a detachable mounting base to simplify installation, service and maintenance.

Mount base (all base types) on an electrical backbox which is at least 1.5" (3.81 cm) deep. For a chart of compatible junction boxes, see *DF-60059*.

NOTE: *Because of the inherent supervision provided by the SLC loop, end-of-line resistors are not required. Wiring “T-taps” or branches are permitted for Style 4 (Class B) wiring. SD355R(A) mounts in a D355PL(A) or DNR(A)/DNRW duct detector housing.*

Operation

Each SD355(A) series detector uses one of 99 possible addresses on the MS-9200 series and up to 318 (159 on each loop) on the MS-9600 series Signaling Line Circuit (SLC). It responds to regular polls from the system and reports its type and status.

The addressable photoelectric sensor in the SD355(A) series has a unique unipolar chamber that responds quickly and uniformly to a broad range of smoke conditions. It can withstand wind gusts up to 4,000 feet-per-minute (20 m/sec.) without sending an alarm level signal. Because of its unipolar chamber, the SD355(A) series is approximately two times more responsive than most photoelectric sensors. This makes it a more stable detector.

Detector Sensitivity Test

Each detector can have its sensitivity tested (required per NFPA 72, Chapter 14 on *Inspection, Testing and Maintenance*) when installed/connected to a MS-9200 series or MS-9600 series addressable fire alarm control panel. The results of the sensitivity test can be printed off the MS-9200 series or MS-9600 series for record keeping.

Specification

Voltage range: 15 – 32 VDC (peak).

Standby current: 300 μ A @ 24 VDC.

LED current: 6.5 mA @ 24 VDC (latched "ON").

Air velocity: 4,000 ft./min. (20 m/sec.) maximum.

Size: 2.1" (5.33 cm) high; base determines diameter.

- **B210LP(A):** 6.1" (15.5 cm) diameter.
- **B501(A):** 4.1" (10.4 cm) diameter.
- **B200SR(A):** 6.875" (17.46 cm) diameter.
- **B224RB(A):** 6.2" (15.748 cm) diameter.

Weight: 3.6 oz. (102 g).

Operating temperature range: for **SD355(A):** 0°C to 49°C (32°F to 120°F); for **SD355T(A):** 0°C to 38°C (32°F to 100°F). **SD355R(A):** installed in a DNR(A)/DNRW -20°C to 70°C (-4°F to 158°F).

Temperature: 0°C – 49°C (32°F – 120°F).

Relative humidity: 10% – 93%, non-condensing.

Listings

Listings and approvals below apply to the SD355(A), SD355T(A), and SD355RT(A) detectors. In some cases, certain modules may not be listed by certain approval agencies, or listing may be in process. Consult factory for latest listing status.

- **UL Listed:** S1059.
- **ULC Listed:** S1059.
- **CSFM:** 7272-0075:0194.
- **MEA:** 243-02-E.
- **FM approved.**

Product Line Information

NOTE: "A" suffix indicates ULC Listed model.

SD355: Addressable photoelectric detector; B210LP base included.

SD355A: Same as SD355 with ULC Listing; B210LPA base included.

SD355T: Same as SD355 but with **thermal** element; B210LP base included.

SD355TA: Same as SD355T with ULC Listing; B210LPA base included.

SD355R: Remote test capable addressable photoelectric detector for use with a D355PL(A) or DNRA/DNRW duct detector housing; B210LP base included.

SD355RA: Same as SD355R with ULC Listing for use with a D355PLA or DNRA duct detector housing; B210LPA base included.

INTELLIGENT BASES

NOTE: "A" suffix indicates ULC Listed model.

NOTE: The detector's plug-in base can be changed off for special applications. For details about intelligent bases and their mounting, see DF-60059.

B210LP(A): Plug-in detector base (included); standard U.S. flanged low-profile mounting base.

B210LPBP: Bulk pack of B210LP; package contains 10.

B501(A): Standard European flangeless mounting base.

B501BP: Bulk pack of B501; package contains 10.

B200SR(A): Intelligent sounder base capable of producing sound output with ANSI Temporal 3 or continuous tone. Replaces B501BH series bases in retrofit applications.

B224RB(A): Plug-in System Sensor **relay** base. Screw terminals: up to 14 AWG (2.0 mm²). Relay type: Form-C. Rating: 2.0 A @ 30 VDC resistive; 0.3 A @ 110 VDC inductive; 1.0 A @ 30 VDC inductive.

B224BI(A): Plug-in System Sensor **isolator** detector base. Maximum 25 devices between isolator bases (see DF-52389).

ACCESSORIES

F110: Retrofit flange to convert B210LP(A) to match the B350LP(A) profile, or to convert older high-profile bases to low-profile.

F110BP: Bulk pack of F110; package contains 15.

F210: Replacement flange for B210LP(A) base.

RA100Z(A): Remote LED annunciator. 3 – 32 VDC. Mounts to a U.S. single-gang electrical box. For use with B501(A) and B210LP(A) bases only.

SMB600: Surface mounting kit

M02-04-00: Test magnet.

M02-09-00: Test magnet with telescoping handle.

XR2B: Detector removal tool. Allows installation and/or removal of detector heads from bases in high ceiling applications.

XP-4: Extension pole for XR2B. Comes in three 5-foot (1.524 m) sections.

T55-127-010: Detector removal tool without pole.

BCK-200B: Black detector covers for use with SD355(A) only; box of 10.

WCK-200B: White detector covers for use with SD355(A) only; box of 10.

Fire•Lite® Alarms is a registered trademark of Honeywell International Inc. ©2011 by Honeywell International Inc. All rights reserved. Unauthorized use of this document is strictly prohibited.



This document is not intended to be used for installation purposes.
We try to keep our product information up-to-date and accurate.
We cannot cover all specific applications or anticipate all requirements.
All specifications are subject to change without notice.



Made in the U.S.A.

For more information, contact Fire•Lite Alarms. Phone: (800) 627-3473, FAX: (877) 699-4105.
www.firelite.com

BG-12LX

Addressable Manual Pull Station



Addressable Devices

General

The Fire-Lite BG-12LX is a state-of-the-art, dual-action (i.e., requires two motions to activate the station) pull station that includes an addressable interface (mounted inside) for Fire-Lite's addressable fire alarm control panels (FACPs). Because the BG-12LX is addressable, the control panel can display the exact location of the activated manual station. This leads fire personnel quickly to the location of the alarm.

Features

- Maintenance personnel can open station for inspection and address setting without causing an alarm condition.
- Built-in bicolor LED, which is visible through the handle of the station, flashes in normal operation and latches steady red when in alarm.
- Handle latches in down position and the word "ACTIVATED" appears to clearly indicate the station has been operated.
- Captive screw terminals wire-ready for easy connection to SLC loop (accepts up to 12 AWG/3.25 mm² wire).
- Can be surface mounted (with SB-10 or SB-I/O) or semi-flush mounted. Semi-flush mount to a standard single-gang, double-gang, or 4" (10.16 cm) square electrical box.
- Smooth dual-action design.
- Meets ADAAG controls and operating mechanisms guidelines (Section 4.1.3[13]); meets ADA requirement for 5 lb. maximum activation force.
- Highly visible.
- Attractive shape and textured finish.
- Key reset.
- Includes Braille text on station handle.
- Optional trim ring (BG12TR).
- Meets UL 38, Standard for Manually Actuated Signaling Boxes.

Construction

Shell, door, and handle are molded of durable polycarbonate material with a textured finish.

Specifications

- **Shipping Weight:** 9.6 oz. (272.15 g)
- **Normal operating voltage:** 24 VDC.
- **Maximum SLC loop voltage:** 28.0 VDC.
- **Maximum SLC standby current:** 375 μ A.
- **Maximum SLC alarm current:** 5 mA.
- **Temperature Range:** 32°F to 120°F (0°C to 49°C)
- **Relative Humidity:** 10% to 93% (noncondensing)
- **For use indoors in a dry location**

Installation

The BG-12LX will mount semi-flush into a single-gang, double-gang, or standard 4" (10.16 cm) square electrical outlet box, or will surface mount to the model SB-10 or SB-I/O surface backbox. If the BG-12LX is being semi-flush mounted, then the optional trim ring (BG12TR) may be used. The BG12TR is

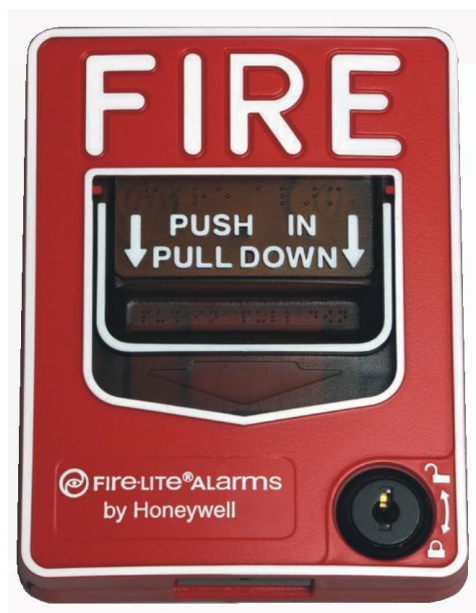

FL PullStation.jpg

usually needed for semi-flush mounting with 4" (10.16 cm) or double-gang boxes (not with single-gang boxes).

Operation

Pushing in, then pulling down on the handle causes it to latch in the down/activated position. Once latched, the word "ACTIVATED" (in bright yellow) appears at the top of the handle, while a portion of the handle protrudes from the bottom of the station. To reset the station, simply unlock the station with the key and pull the door open. This action resets the handle; closing the door automatically resets the switch.

Each manual station, on command from the control panel, sends data to the panel representing the state of the manual switch. Two rotary decimal switches allow address settings (1 – 159 with Breakaway Tab removed for MS-9600 Series, 1 – 99 and MS-9200UDLS, 1 – 50 for MS-9050UD).

Architectural/Engineering Specifications

Manual Fire Alarm Stations shall be non-coded, with a key-operated reset lock in order that they may be tested, and so designed that after actual Emergency Operation, they cannot be restored to normal except by use of a key. An operated station shall automatically condition itself so as to be visually detected as activated. Manual stations shall be constructed of red-colored polycarbonate material with clearly visible operating instructions provided on the cover. The word FIRE shall appear on the front of the stations in white letters, 1.00 inches (2.54 cm) or larger. Stations shall be suitable for surface mounting on matching backbox SB-10 or SB-I/O; or semi-flush mounting on a standard single-gang, double-gang, or 4" (10.16 cm) square electrical box, and shall be installed

within the limits defined by the Americans with Disabilities Act (ADA) or per national/local requirements. Manual Stations shall be Underwriters Laboratories listed.

Manual stations shall connect with two wires to one of the control panel SLC loops. The manual station shall, on command from the control panel, send data to the panel representing the state of the manual switch. Manual stations shall provide address setting by use of rotary decimal switches.

Product Line Information

BG-12LX: Dual-action addressable pull station. Includes key locking feature. (Listed for Canadian and non-Canadian applications.)

SB-10: Surface backbox; metal.

SB-I/O: Surface backbox; plastic.

BG12TR: Optional trim ring.

17003: Keys, set of two.

Agency Listings and Approvals

In some cases, certain modules or applications may not be listed by certain approval agencies, or listing may be in process. Consult factory for latest listing status.

- **UL/ULC Listed:** S711 (listed for Canadian and non-Canadian applications).
- **MEA:** 67-02-E.
- **CSFM:** 7150-0075:0184.
- **FM Approved.**

Patented: U.S. Patent No. D428,351; 6,380,846; 6,314,772; 6,632,108.

FireLite® Alarms® is a registered trademark of Honeywell International Inc. ©2012 by Honeywell International Inc. All rights reserved. Unauthorized use of this document is strictly prohibited.



This document is not intended to be used for installation purposes.
We try to keep our product information up-to-date and accurate.
We cannot cover all specific applications or anticipate all requirements.
All specifications are subject to change without notice.



Made in the U.S. A.

For more information, contact Fire•Lite Alarms. Phone: (800) 627-3473, FAX: (877) 699-4105.
www.firelite.com

D355PL(A)/DNRW InnovairFlex

Intelligent Non-Relay Photoelectric Duct Smoke Detector



Intelligent Addressable Devices

General

The Fire•Lite InnovairFlex® D355PL(A) intelligent non-relay photoelectric duct smoke detector and DNRW watertight non-relay photoelectric duct smoke detector feature a pivoting housing that fits both square and rectangular footprints capable of mounting to a round or rectangular duct.

DNRW duct smoke detector, with its NEMA-4 rating, is listed as a watertight, UV resistant enclosure providing protection against falling dirt, rain, and windblown dust, splashing and hose directed water, allowing operators to use the detector in the most extreme environments.

These units sense smoke in the most challenging conditions, operating in airflow speeds of 100 to 4,000 feet per minute (0.5 to 20.32 m/s), temperatures of -4°F to 158°F (-20°C to 70°C), and a humidity range of 0 to 95 percent (non-condensing.)

An improved cover design isolates the sensor head, which allows for ease of maintenance. A cover tamper feature indicates a trouble signal for a removed or improperly installed sensor cover. The Fire•Lite InnovairFlex housing provides a 3/4-inch conduit knockout and ample space to facilitate easy wiring and mounting of a relay module.

The Fire•Lite InnovairFlex duct smoke detector can be customized to meet local codes and specifications without additional wiring. The new InnovairFlex product line is compatible with all previous Innovair models, including remote test accessories.

Features

- Photoelectric, integrated low-flow technology.
- Air velocity rating from 100 ft/min to 4,000 ft/min (0.5 m/s to 20.32 m/s).
- Versatile mounting options: square or rectangular configuration.
- Broad ranges for operating temperature (-4°F to 158°F, -20°C to 70°C) and humidity (0% to 95% non-condensing).
- Patented sampling tube installs from front or back of the detector with no tools required.
- Cover tamper signal.
- Increased wiring space with a newly added 3/4" conduit knockout.
- Available space within housing to accommodate mounting of a relay module.
- Easily accessible code wheels on sensor head (sold separately).
- Clear cover for convenient visual inspection.
- Remote testing capability.
- Requires com line power only.
- Accommodates the installation of an addressable relay module, sold separately, (CRF-300) for applications requiring a Form-C relay.



Specifications

Size: (Rectangle) 14.38 in (37 cm) Length; 5 in (12.7 cm) Width, 2.5 in (6.6 cm) Depth.

Size: (Square) 7.75 in (19.7 cm) Length; 9 in (22.9 cm) Width; 2.5 in (6.35 cm) Depth.

Weight: 1.6 lb (0.73 kg).

Operating Temperature Range: -4°F to 158°F (-20°C to 70°C).

Storage Temperature Range: -22°F to 158°F (-30°C to 70°C).

Operating Humidity Range: 0% to 95% relative humidity (non-condensing).

Air Duct Velocity: 100 to 4,000 ft/min (0.5 to 20.32 m/s).

Accessories

Fire•Lite provides system flexibility with a variety of accessories, including two remote test stations and different means of visible and audible system annunciation. As with our duct smoke detectors, all duct smoke detectors accessories are UL listed.

D355PLs and DNRWs with a date code of 0013 or higher do not require external 24VDC for remote test applications when used with a remote-test-capable detector.

ACCESSORY CURRENT LOADS AT 24 VDC

Device	Standby	Alarm
RA100Z	0mA	12 mA Max
RTS151/ RTS151KEY	0mA	12mA Max

Agency Listings and Approvals

Consult product manual for lists of compatible UL-Listed devices. In some cases, certain modules may not be listed by certain approval agencies, or listing may be in process. Consult factory for latest listing status.

- **UL:** S1059.
- **ULC:** S1059

- **CSFM:** 3242-1653:0209.
- **FM approved.**

Product Line Information

D355PL: Intelligent non-relay photoelectric low flow smoke detector housing. Includes SD355R Detector.

DNRW: Watertight intelligent non-relay photoelectric low flow duct smoke detector housing. Does not include detector head.

SD355R(A): Remote test capable addressable low-profile photoelectric smoke detector.

SD355(A): Addressable low-profile photoelectric smoke detector.

DCOIL: Remote test coil. Required for older DNR(W) duct detector housing.

DST1: Metal sampling tube duct width up to 1 ft (0.3m).

DST1.5: Metal sampling tube duct widths up to 1 ft to 2 ft (0.3 to 0.6 m).

DST3: Metal sampling tube duct widths up to 2 ft to 4 ft (0.6 to 1.2 m).

DST5: Metal sampling tube duct widths up to 4 ft to 8 ft (1.2 to 2.4 m).

DST10: Metal sampling tube duct widths up to 8 ft to 12 ft (2.4 to 3.7 m).

DH400OE-1: Weatherproof enclosure.

ETX: Metal exhaust tube duct, width 1 ft (0.3 m).

M02-04-00: Test magnet.

P48-21-00: End cap for metal sampling tubes.

RA100Z: Remote annunciator alarm LED.

RTS151: Remote test station.

RTS151KEY: Remote test station with key lock.

Important Note

- DNRW duct detector housings with a date code of 0013 or higher do not require a DCOIL or auxiliary 24 VDC for remote test applications when used with a remote test capable detector.
- DNRW duct detector housings with a date code of 0012 or earlier require a DCOIL and auxiliary 24 VDC power for remote test applications.

Fire•Lite® Alarms is a registered trademark of Honeywell International Inc.
©2012 by Honeywell International Inc. All rights reserved. Unauthorized use
of this document is strictly prohibited.



This document is not intended to be used for installation purposes.
We try to keep our product information up-to-date and accurate.
We cannot cover all specific applications or anticipate all requirements.
All specifications are subject to change without notice.



Made in the U.S. A.

For more information, contact Fire•Lite Alarms. Phone: (800) 627-3473, FAX: (877) 699-4105.
www.firelite.com

Duct Smoke Detector Accessories



Miscellaneous

General

Duct smoke detector accessories add functionality to the duct smoke system by allowing quick, convenient inspections at eye level and effective audible and visual notification options. All System Sensor duct smoke detectors and accessories are UL listed.

Specifications

APA151 PIEZO ANNUNCIATOR

The **APA151** piezo annunciator, which replaces the APA451 with a new, improved look, provides an audible alarm signal, a red LED to indicate alarm status, and a green LED to indicate power status. It is intended for use with System Sensor 4-wire conventional duct smoke detector applications without a system control panel, to comply with NFPA 90A.



APA151.wmf

APA151 Piezo Annunciator	
Voltage	Regulated 24 VDC
Operating Voltage	16 to 33 VDC
Maximum Alarm Current	30 mA
Temperature Range	32°F to 120°F (0°C to 49°C)
Relative Humidity	10 to 93%, non-condensing
Wire Gauge	12 to 18 AWG
Dimensions	4.6" H x 2.9" W x .45" D

MHR/MHW MINI-HORNS

The **MHR** and **MHW** SpectrAlert® Advance mini-horns feature temporal or continuous tones at high and low volume settings. Their small footprint allows mounting to single-gang back boxes for applications where a small device is desired.



MHR.wmf, MHW.wmf



60535cov.wmf

MHR/MHW SpectrAlert Advance Mini-Horns

Voltage	Regulated 12 DC or FWR (Full Wave Rectified) or Regulated 24 VDC or FWR
Operating Voltage	8 to 33 VDC (9 to 33 VDC with Sync-Circuit™ Module)
Sounder Current Draw	22 mA RMS max. at 8 to 17.5 Volts DC 17 mA RMS max. at 8 to 17.5 Volts FWR 29 mA RMS max. at 16 to 33 Volts DC 25 mA RMS max. at 16 to 33 Volts FWR
Temperature Range	32°F to 120°F (0°C to 49°C)
Humidity Range	10 to 93% non-condensing
Nominal Sounder Frequency	3 kHz
Wire Gauge	12 to 18 AWG
Dimensions	4.6"H x 2.9"W x 0.45"D

RA100Z/RA100ZA REMOTE ANNUNCIATORS

The **RA100Z** and **RA100ZA** remote annunciators are designed for both conventional and intelligent applications. Their red LED provides visual indication of an alarm condition.



RA100Z.wmf

RA100Z/RA100ZA Remote Annunciator	
Voltage Range	Conventional System: 3.1 to 32 VDC Intelligent System: 18 to 32 VDC
Maximum Alarm Current	10 mA
Dimensions	4.6"H x 2.8"W x 1.3"D

RTS151/RTS151KEY REMOTE TEST STATIONS

The **RTS151** and **RTS151KEY** remote test stations are automatic fire detector accessories designed to test duct smoke detectors from a convenient location. For 4-wire detectors, the **RTS151KEY** test station features a multi-colored LED that alternates between steady green and red. For 2-wire detectors, the LED illuminates red for alarm.



RTS151.wmf, RTS151KEY.wmf

RTS151 Remote Test Station	
Power Requirements	Alarm LED 2.8 to 32 VDC, 10 mA max. Total Current: 95 mA max.
Test Switch	10 VA @ 32 VDC
Reset Switch	10 VA @ 32 VDC
Alarm Response Time	40 seconds max.
Temperature Range	14°F to 140°F (-10°C to 60°C)
Relative Humidity	95% non-condensing
Wire Gauge	14 to 18 AWG
Dimensions	4.8"H x 2.9"W x 1.4"D

RTS151KEY Remote Test Station with Key

Power Requirements	Power LED (Green): 14 to 35 VDC, 12 mA max. Alarm LED (RED): 2.8 to 32 VDC, 12 mA max.
Alarm Response Time	40 seconds max.
Temperature Range	14°F to 140°F (-10°C to 60°C)
Relative Humidity	95% non-condensing
Wire Gauge	14 to 18 AWG
Dimensions	4.6"H x 2.75"W x 1.8"D

RTS2/RTS-AOS MULTI-SIGNALLING ACCESSORIES

The **RTS2** and **RTS2-AOS** multi-signaling accessories are designed to work with InnovairFlex 4-wire conventional duct smoke detectors. These accessories include a key switch that can be used to select one of two connected sensors to be tested, reset, or both by a push button switch. They also enable sensitivity measurements using the SENS-RDR sensitivity reader (sold separately). The **AOS** (Add-On Strobe) is an optional accessory included with the **RTS2-AOS** model.



RTS-AOS.wmf, AOS.wmf

RTS2 and RTS-AOS Multi-signaling Accessory

Voltage	20 to 29 VDC
Power Requirements	Standby: 3.0 mA max. Trouble: 16.0 mA max. Alarm without Strobe: 30 mA max. Alarm with Strobe: 55 mA max.
Sounder	85 dBA at 10 ft.
Temperature Range	14°F to 140°F (-10°C to 60°C)
Relative Humidity	95% non-condensing
Wire Gauge	14 to 22 AWG
Dimensions	4.8"W x 5.3"H x 1.6"D

Product Line Information

APA151: Piezo Annunciator

MHR: Mini-Horn, Red

MHW: Mini-Horn, White

RA100Z/RA100ZA: Remote Annunciator

RTS151: Remote Test Station

RTS151KEY: Remote Test Station with Key

RTS2: Multi-signaling Accessory

AOS: Add-On Strobe

RTS2-AOS: Multi-Signaling Accessory

Temperature and Humidity Ranges

This system meets NFPA requirements for operation at 0 – 49°C/32 – 120°F and at a relative humidity 93% ± 2% RH (noncondensing) at 32°C ± 2°C (90°F ± 3°F). However, the useful life of the system's standby batteries and the electronic components may be adversely affected by extreme temperature ranges and humidity. Therefore, it is recommended that this system and its peripherals be installed in an environment with a normal room temperature of 15 – 27°C/60 – 80°F.

Agency Listings and Approvals

The listings and approvals below apply to the basic products. In some cases, certain modules may not be listed by certain approval agencies, or listing may be in process. Consult factory for latest listing status.

- **UL: S4011 (APA 151, MHR, MHW), S2522 (RTS2, RA100Z, RTS151, RTS151KEY, RTS2-AOS)**
- **FM Approved**
- **CSFM: 7135-1653:0212**

Fire•Lite® Alarms and **System Sensor®** are registered trademarks of Honeywell International Inc.
©2012 by Honeywell International Inc. All rights reserved. Unauthorized use of this document is strictly prohibited.



This document is not intended to be used for installation purposes.
We try to keep our product information up-to-date and accurate.
We cannot cover all specific applications or anticipate all requirements.
All specifications are subject to change without notice.



Made in the U.S. A.

For more information, contact Fire•Lite Alarms. Phone: (800) 627-3473, FAX: (877) 699-4105.
www.firelite.com

CRF-300(A)

Relay Module



Addressable Devices

General

The **CRF-300(A)** Addressable Relay Module provides the system with a dry-contact output for activating a variety of auxiliary devices, such as fans, door holders, dampers, control equipment, etc. Addressability allows the dry contact to be activated through panel programming, on a select basis.

LiteSpeed™ is a communication protocol developed by Fire•Lite Engineering that greatly enhances the speed of communication between analog intelligent devices. Intelligent devices communicate in a grouped fashion. If one of the devices within the group has new information, the panel CPU stops the group poll and concentrates on single points. The net effect is response speed greater than five times that of other designs.

Features

- Built-in type identification automatically identifies these devices to the control panel.
- Internal circuitry and relay powered directly by two-wire SLC loop.
- Integral LED “blinks” green each time a communication is received from the control panel and turns on in steady red when activated.
- High noise immunity (EMF/RFI).
- Wide viewing angle of LED.
- SEMS screws with clamping plates for wiring ease.
- Direct-dial entry of address: 01– 159 for MS-9600(A) series panels, 01 – 99 on MS-9200UDLS(A) and MS-9050UD(A).

Applications

The CRF-300(A) may be programmed to operate dry contacts for door holders, Air Handling Unit shutdown, etc., and to reset four-wire smoke detector power.

Construction

- The face plate is made of off-white heat-resistant plastic.
- Controls include two rotary switches for direct-dial entry of address setting.
- The CRF-300(A) is configured for a single Class B (Style Y) or Class A (Style Z) Notification Appliance Circuit.
- The CRF-300(A) provides two Form-C dry contacts that switch together.

Operation

Each CRF-300(A) uses one of the addresses on a SLC loop. It responds to regular polls from the control panel and reports its type and status, including the open/normal/short status of its Notification Appliance Circuit (NAC). The LED blinks with each poll received. On command, it activates its internal relay.

NOTE: Open/short supervision is suspended with the CRF-300.

Rotary switches set a unique address for each module. The address may be set before or after mounting. The built-in TYPE CODE (not settable) will identify the module to the control panel, so as to differentiate between a control module and a relay module.



CRF-300(A)

Specifications

Normal operating voltage: 15 to 32 VDC.

Maximum SLC current draw: 6.5 mA (LED on).

Average operating current: 230 μ A direct poll (CLIP mode), 255 μ A group poll (LiteSpeed mode) with LED flashing.

EOL resistance: not used.

Temperature range: 32°F to 120°F (0°C to 49°C).

Humidity range: 10% to 93% non-condensing.

Dimensions: 4.5" (11.43 cm) high x 4" (10.16 cm) wide x 1.25" (3.175 cm) deep. Mounts to a 4" (10.16 cm) square x 2.125" (5.398 mm) deep box.

Relay Contact Ratings

Load Description	Application	Maximum Voltage	Current Rating
Resistive	Non-Coded	30 VDC	3.0 A
Resistive	Coded	30 VDC	2.0 A
Resistive	Non-Coded	110 VDC	0.9 A
Resistive	Non-Coded	125 VAC	0.9 A
Inductive (L/R=5ms)	Coded	30 VDC	0.5 A
Inductive (L/R=2ms)	Coded	30 VDC	1.0 A
Inductive (PF=0.35)	Non-Coded	125 VAC	0.5 A

Agency Listings and Approvals

In some cases, certain modules may not be listed by certain approval agencies, or listing may be in process. Consult factory for latest listing status.

- **UL:** S2424
- **ULC:** S2424
- **FM approved**
- **CSFM:** 7300-0075:185
- **MEA:** 72-01-E

Product Line Information

CRF-300(A): Intelligent addressable relay module.

: Intelligent addressable relay module, ULC listed model.

SMB500: Optional surface-mount backbox.

NOTE: For installation instructions, see document 156-1190-005 and refer to the SLC Wiring Manual, document 51309.

LiteSpeed™ is a trademark and **Fire•Lite®** Alarms is a registered trademark of Honeywell International Inc.
©2009 by Honeywell International Inc. All rights reserved. Unauthorized use of this document is strictly prohibited.



This document is not intended to be used for installation purposes.
We try to keep our product information up-to-date and accurate.
We cannot cover all specific applications or anticipate all requirements.
All specifications are subject to change without notice.



Made in the U.S. A.

For more information, contact Fire•Lite Alarms. Phone: (800) 627-3473, FAX: (877) 699-4105.
www.firelite.com

FCPS-24FS8

8-Amp, 24-Volt Power Supply



Power Supplies/Accessories

General

The Fire•Lite FCPS-24FS8(C/E) is a compact, cost-effective, 8-amp remote power supplies with battery charger. The FCPS-24FS8C/E may be connected to any 12 or 24 volt fire alarm control panel (FACP) or may stand-alone. Primary applications include notification appliance (bell) circuit (NAC) expansion (to support ADA requirements and NAC synchronization) or auxiliary power to support 24 volt system accessories. The FCPS provides *regulated and filtered* 24 VDC power to four notification appliance circuits configured as either two Class B (Style Y) and Class A (Style Z, with ZNAC-4 option module) or four class B only. Alternately, the four outputs may be configured as any combination of resettable/non-resettable power outputs (optimal for powering four-wire smoke detectors. The FCPS-24FS8(C/E) also contains a battery charger capable of charging up to 18.0 Amp hour batteries. FCPS-24FS8C/E is ULC-listed.

NOTE: Unless otherwise specified, the term FCPS-24FS8 used in this document refers to the standard FCPS-24FS8, FCPS-24FS8C, FCPS-24FS8E

Features

- UL-Listed Notification Appliance Circuit (NAC) synchronization using System Sensor, Wheelock, or Gentex “Commander²” appliances.
- Operates as a “sync-follower” or as a “sync-generator” (default). *See note on page 2.*
- Contains two fully-isolated input/control circuits - triggered from FACP NAC (NAC expander mode) or jumped permanently “ON” (stand-alone mode).
- Two Class B (Style Y) or Class A (Style Z, with ZNAC-4 module) NACs (circuits 1 & 3)
- 8-amp full load output, with 3 amps maximum/circuit, in NAC expander mode (UL 864).
- 6-amp continuous output in stand-alone mode (UL 1481).
- Compatible with coded inputs; signals passed through.
- Optional power-supervision relay (EOLR-1).
- In stand-alone mode, output power circuits may be configured as: resettable, (reset line from FACP required), non-resettable, or a mix of two and two.
- Fully regulated and filtered power output - optimal for powering four-wire smoke detectors, annunciators, and other system peripherals requiring regulated/filtered power.
- Power-limiting technology meets UL power-limiting requirements.
- Form-C normally-closed trouble relay.
- Fully supervised power supply, battery, and NACs.
- Selectable earth fault detection.
- AC trouble report selectable for immediate 2-hour delay.
- Works with virtually any UL 864 fire alarm control which utilizes an industry-standard reverse-polarity notification circuit (including unfiltered and unregulated bell power).
- Requires input trigger voltage of 9 - 32 VDC.
- Self-contained in compact, locking cabinet - 15”H x 14.5”W x 2.75”D (cm: 38.1H x 36.83W x 6.985D).



- Includes integral battery charger capable of charging up to 18 AH batteries. Cabinet capable of housing 7.0 AH batteries.
- Battery charger may be disabled via DIP switch for applications requiring larger batteries.
- Fixed, clamp-type terminal blocks accommodate up to 12 AWG (3.1mm²) wire.

Specifications

Primary (AC) Power:

- FCPS-24FS8: 120 VAC, 60 Hz, 3.2A maximum.
- FCPS-24FS8/E: 240 VAC, 50 Hz, 1.6A maximum.
- Wire Size: minimum #14 AWG (2.0mm²) with 600 V insulation.

Control Input Circuit:

- **Trigger Input Voltage:** 9 to 32 VDC.
- **Trigger Current:** 2.0 mA (16 - 32 V); Per Input: 1.0 mA (9 - 16 V).

Trouble Contact Rating:

5 A at 24 VDC.

Auxiliary Power Output: Specific application power 500 mA maximum.

Output Circuits:

- +24 VDC filtered, regulated.
- 3.0 A maximum for any one circuit.
- Total continuous current for all outputs (stand-alone mode):
 - FCPS-24FS8: 6.0 A maximum.
- Total short-term current for all outputs (NAC expander mode):
 - FCPS-24FS8: 8.0 A maximum.

Secondary Power (Battery) Charging Circuit:

- Supports lead-acid batteries only.
- Float-charge voltage: 27.6 VDC.
- Maximum current charge: 250 mA.
- Maximum battery capacity: 7.0 AH.

Applications

Example 1: Expand notification appliance power an additional 8.0 A. Use up to four Class B (Style Y) outputs or four Class A (Style Z) outputs (using ZNAC-4). For example, the FACP notification appliance circuits will activate the FCPS when reverse-polarity activation occurs. Trouble conditions on the FCPS are sensed by the FACP through the notification appliance circuit.

Example 2: Use the FCPS to expand auxiliary regulated 24-volt system power up to 6.0 A. Both resettable and non-resettable power options are available. Resettable outputs are created by connecting the resettable output from the FACP to one or both of the FCPS inputs.

Example 3: Use addressable control modules to activate the FCPS instead of activating it through the FACP notification appliance circuits. This typically allows for mounting the FCPS at greater distances* away from the FACP while expanding system architecture in various applications.

For example, an addressable control module is used to activate the FCPS, and an addressable monitor module is used to sense FCPS trouble conditions. Local auxiliary power output from the FCPS provides power to the addressable control module.

**NOTE: Addressable FACP's are capable of locating control and monitor modules at distances of up to 10,000 feet (3,046 meters) .*

Sync Follower/Generator Note

In some installations, it is necessary to synchronize the flash timing of all strobes in the system for ADA compliance. Strobes accomplish this by monitoring very short timing pulses on the NAC power which are created by the FACP. When installed at the end of a NAC wire run, the FCPS-24FS8 can track (i.e. "follow") the strobe synchronization timing pulses on the existing NAC wire run. This maintains the overall system flash timing of the additional strobes attaches to the FCPS.

When the FCPS-24FS8 is configured (via DIP switch settings) as a "sync follower," the FCPS's NAC outputs track the strobe synchronization pulses present at the FCPS's sync input terminal. The pulses originate from an upstream FACP or other power supply.

When the FCPS-24FS8 is configured (via DIP switch settings) as a "sync generator," the FCPS's sync input terminals are not used. Rather, the FCPS is the originator of the strobe synchronization pulses on the FCPS's NAC outputs. In "sync generator" mode, the sync type (System Sensor, Wheelock, or Gentex) is selectable via DIP switch settings.

Standards and Codes

The FCPS-24FS8 complies with the following standards:

- **NFPA 72** National Fire Alarm Code.
- **UL 864** Standard for Control Units for Fire Alarm Systems (NAC expander mode).
- **UL 1481** Power Supplies for Fire Alarm Systems.

Agency Listings and Approvals

These listings and approvals apply to the modules specified in this document. In some cases, certain modules or applications may not be listed by certain approval agencies, or listing may be in process. Consult factory for latest listing status.

- **UL Listed:** S2424
- **ULC Listed:** S2424
- **CSFM Approved:** 7315-0075:206
- **MEA:** 219-02E

Ordering Information

FCPS-24FS8: 6.0 A, 120 VAC remote charger power supply. Includes main printed circuit board, transformers, enclosure (15"H x 14.5"W x 2.75"D [cm: 38.1H x 36.83W x 6.985D]), and installation instructions.

FCPS-24FS8 is ULC-listed.

FCPS-24FS8E: 6.0 A, 240 VAC remote charger power supply. Includes main printed circuit board, transformers, enclosure (15"H x 14.5"W x 2.75"D [cm: 38.1H x 36.83W x 6.985D]), and installation instructions.

ZNAC-4: Class A (Style Y) NAC option module.

EOLR-1: 12/24 VDC end-of-line relay for monitoring four-wire smoke detector power.

BAT-1270: Battery, 12-volt, 7.0 AH (two required).

PS-1270: Battery, 12-volt, 7.0 AH (two required).

90286: Optional module mounting kit, is required to install an addressable module on the power supply main circuit board.

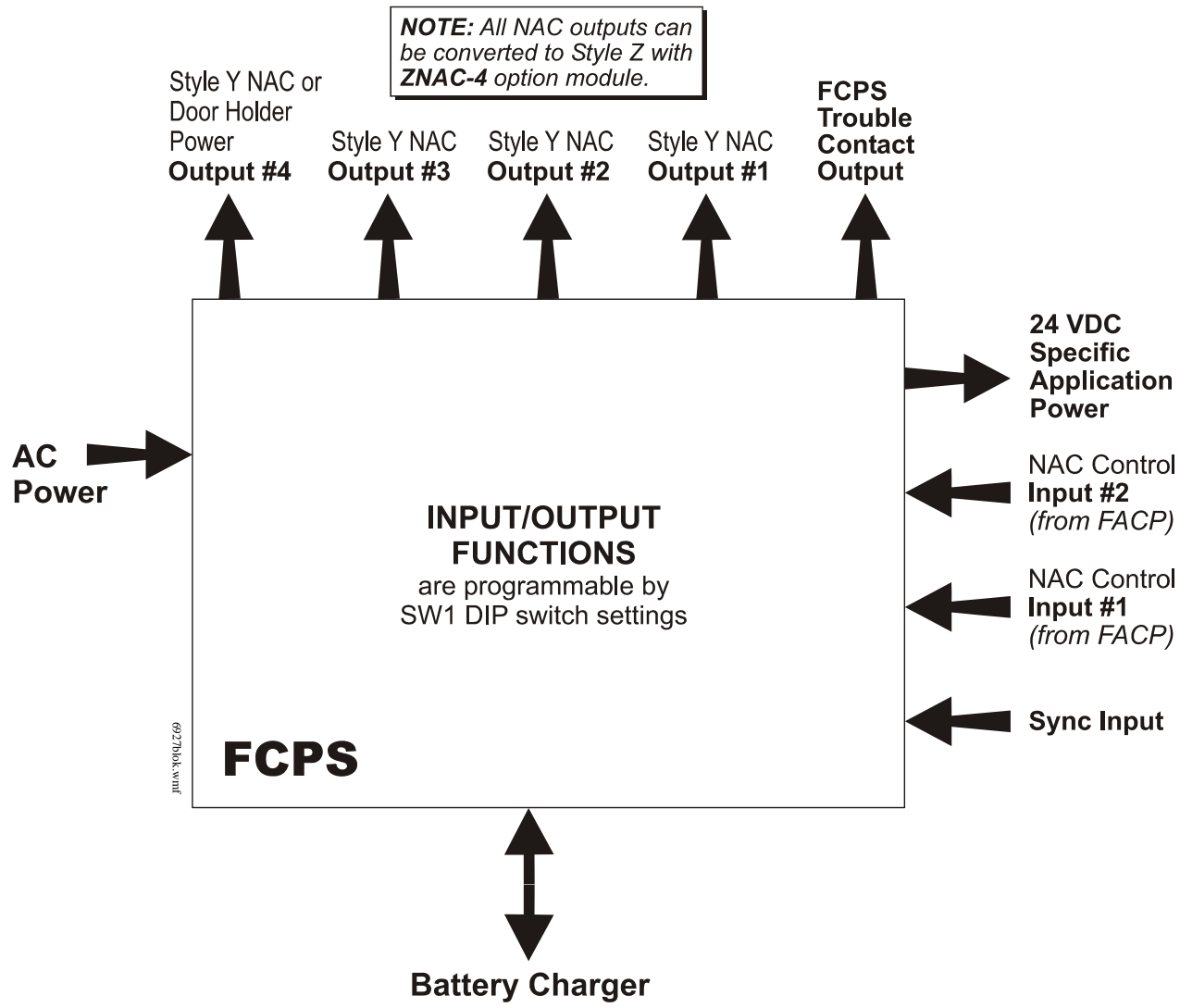

Simplified Block Diagram

BAT Series Batteries

Sealed Lead-Acid or Gell Cell



Power Supplies

General

BAT Series Batteries feature a new part-numbering/listing system — providing an improved method of delivery for NOTIFIER-approved sealed lead-acid batteries for all your fire alarm system needs. Multiple brands of batteries are now offered under generic part numbers, reducing backorder situations and permitting us to deliver these products in a more timely fashion. NOTIFIER has approved the multiple brands listed below as possible product shipped for a given part number. Please note that any incoming orders for “PS Series” batteries will be converted to the equivalent BAT Series part numbers.



6933cov.jpg

Features

- Provide secondary power for control panels.
- Sealed and maintenance-free.
- Overcharge protected.
- Easy handling with leakproof construction.
- Ruggedly constructed, high-impact case (ABS, polystyrene, or polypropylene, depending on models).
- Long service life.
- Compact design.

Agency Listings and Approvals

The listings and approvals below apply to BAT Series Batteries. In some cases, certain modules may not be listed by certain approval agencies, or listing may be in process. Consult factory for latest listing status.

- **UL Recognized Components:** files MH19884 (*B & B Battery*), MH20567 (*UPG, previously Jolt*), MH20845 (*Power-Sonic*).

Part Number Reference

CURRENT Part Number	BATTERY DESCRIPTION	ALTERNATES APPROVED: manufacturers and P/Ns shipped under BAT P/Ns
BAT-1250	12 V, 5 AH, sealed.	BP5-12 (B&B Battery); PS-1250 (Power-Sonic); SA1250 (Jolt) to be replaced with UB1250 (UPG).
BAT-1250	12 V, 5 AH, sealed.	BP5-12 (B&B Battery); PS-1250 (Power-Sonic); SA1250 (Jolt) to be replaced with UB1250 (UPG).
BAT-1270	12 V, 7 AH, sealed.	BP7-12 (B&B Battery); PS-1270 (Power-Sonic); SA1272 (Jolt) to be replaced with UB1270 (UPG).
BAT-12120	12 V, 12 AH, sealed.	BP12-12 (B&B Battery); PS-12120 (Power-Sonic); SA12120 (Jolt) to be replaced with UB12120 (UPG).
BAT-12180	12 V, 18 AH, sealed.	PS-12180 (Power-Sonic); SA12180 (Jolt) to be replaced with UB12180 (UPG).
BAT-12180	12 V, 18 AH, sealed.	PS-12180 (Power-Sonic); SA12180 (Jolt) to be replaced with UB12180 (UPG).
BAT-12260	12 V, 26 AH, sealed.	BP26-12 (B&B Battery); PS-12260 (Power-Sonic); SA12260 (Jolt) to be replaced with UB12260 (UPG).
BAT-12550	12 V, 55 AH, sealed.	PS-12550 (Power-Sonic); XSA12550 (Jolt) to be replaced with UB12550 (UPG).
BAT-12550	12 V, 55 AH, sealed.	PS-12550 (Power-Sonic); XSA12550 (Jolt) to be replaced with UB12550 (UPG).
BAT-121000	12 V, 100 AH, gell cell.	PS-121000 (Power-Sonic); XSA121000A (Jolt) to be replaced with UB121000 (UPG).

POWER-SONIC

Part Number Reference

1109t1.tbl

MODEL	Nominal Voltage V	Nominal Capacity @ 20 hr. rate A.H.	Discharge Current @20 hr. rate mA	DIMENSIONS									
				Width		Depth		Height		Height over terminal		Weight	
				in.	mm	in.	mm	in.	mm	in.	mm	lb.	kg.
PS-1250	12	5	250	3.54	90	2.76	70	4.02	102	4.21	107	4.1	1.9
PS-1270	12	7	325	5.94	151	2.56	65	3.7	94	3.86	98	5.7	2.6
PS-12120	12	12	600	5.94	151	3.86	98	3.7	94	3.86	98	8.8	4
PS-12180	12	18	875	7.13	181	2.99	76	6.57	167	6.57	167	12.8	5.8
PS-12250	12	25	1300	6.89	175	6.54	166	4.92	125	4.92	125	18.7	8.5
PS-12550	12	55	3000	10.25	260	6.6	168	8.2	208	9.45	240	39.7	18
PS-121000	12	100	5000	12	305	6.6	168	8.2	208	9.45	240	65.7	29.8

Characteristic Discharge Curves

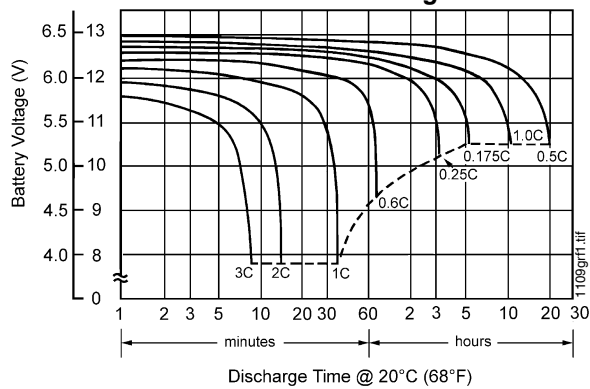

Effect of Temperature on Capacity

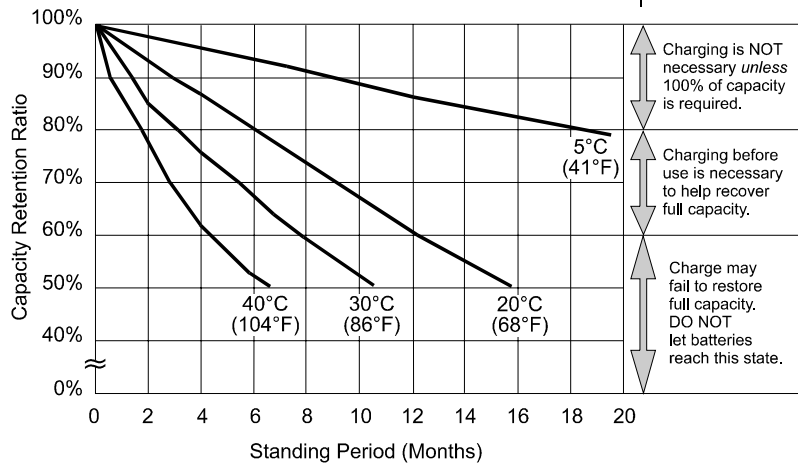
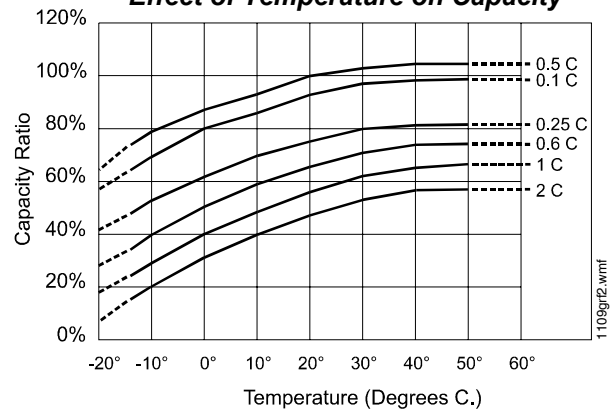

**at left:
PS-121000
Shelf-Life
and Storage**

Charging is NOT necessary unless 100% of capacity is required.
Charging before use is necessary to help recover full capacity.
Charge may fail to restore full capacity. DO NOT let batteries reach this state.

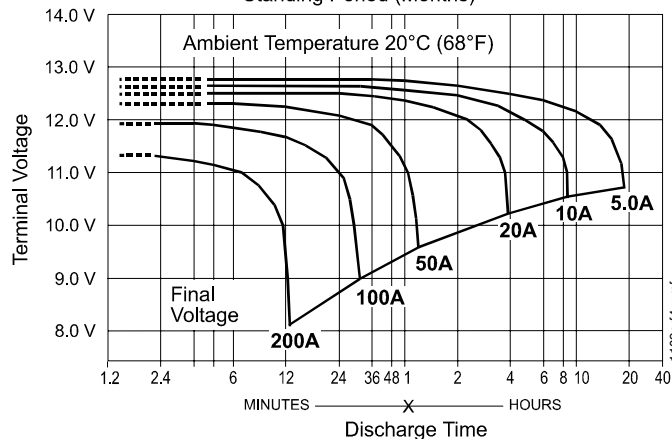

**at left:
PS-121000
Discharge
Characteristics**

SpectrAlert® Advance

Selectable Output Notification Appliances



Audio/Visual Devices

General

System Sensor® SpectrAlert® Advance selectable-output horns, strobes and horn/strobes are rich with features guaranteed to cut installation times and maximize profits. The SpectrAlert Advance series of notification appliances is designed to simplify your installations, with features such as: plug-in designs, instant feedback messages to ensure correct installation of individual devices, and eleven field-selectable candela settings for wall and ceiling strobes and horn/strobes.

More specifically, when installing Advance products, first attach a universal mounting plate to a four-inch square, four-inch octagon, or double-gang junction box. The two-wire mounting plate attaches to a single-gang junction box.

Then, connect the notification appliance circuit wiring to the SEMS terminals on the mounting plate.

Finally, attach the horn, strobe, or horn/strobe to the mounting plate by inserting the product's tabs in the mounting plate's grooves. The device will rotate into position, locking the product's pins into the mounting plate's terminals. The device will temporarily hold in place with a catch until it is secured with a captured mounting screw.

SpectrAlert Advance products allow you to choose:

- 12 or 24 volts.
- 15, 15/75, 30, 75, 95, 110, 115, 135, 150, 177, or 185 candela by way of a rear-mounted slide switch and front viewing window.
- Horn tones and volume by way of a rotary switch.
- The SpectrAlert Advance series includes outdoor notification appliances. Outdoor strobes and horn/strobes (two-wire and four-wire) are available for wall or ceiling. Outdoor horns are available for wall only. All System Sensor outdoor products are rated between -40°F and 151°F (-40°C and 66°C) in wet or dry applications.

Models available:

- Indoor wall-mount: horn, strobe, 2-wire horn/strobe, 4-wire horn/strobe.
- Indoor ceiling-mount: strobe, 2-wire horn/strobe, 4-wire horn/strobe.
- Outdoor wall-mount: horn, strobe, 2-wire horn/strobe, 4-wire horn/strobe.
- Outdoor ceiling-mount: strobe, 2-wire horn/strobe, 4-wire horn/strobe.

Features

- Plug-in design.
- Same mounting plate for wall- and ceiling-mount units.
- Shorting spring on mounting plate for continuity check before installation.
- Captive mounting screw.
- Tamper-resistance capability.
- Field-selectable candela settings on wall and ceiling units: 15, 15/75, 30, 75, 95, 110, 115, 135, 150, 177, 185.
- Automatic selection of 12 or 24 volt operation at 15 and 15/75 candela.
- Outdoor wall and ceiling products.



Indoor Ceiling
Horn/Strobe



Outdoor Ceiling
Strobe



Indoor Wall
Horn/Strobe



Indoor Ceiling
Strobe



Indoor Wall
Horn



Outdoor Wall
Strobe

- Outdoor products rated from -40°F and 151°F (-40°C and 66°C).
- Outdoor products rainproof per UL50 (NEMA 3R) and weatherproof per NEMA 4X, IP56
- Minimal intrusion into the backbox.
- Horn rated at 88+ dbA at 16 volts.
- Rotary switch for tone selection.
- Three horn volume settings.
- Electrically compatible with existing SpectrAlert products.

Engineering Specifications

SpectrAlert Advance horns, strobes, and horn/strobes shall mount to a standard 4.0" x 4.0" x 1.5" (10.16 x 10.16 x 3.81 cm) backbox, 4.0" (10.16 cm) octagonal backbox, or a double-gang backbox. Two-wire products shall also mount to a single-gang 2.0" x 4.0" x 1.875" (5.08 x 10.16 x 4.763 cm) backbox. A universal mounting plate shall be used for mounting ceiling and wall products. The notification appliance circuit wiring shall terminate at the universal mounting plate. Also, SpectrAlert Advance products, when used with the Sync•Circuit™ Module accessory, shall be powered from a non-coded notification appliance circuit output and shall operate on a nominal 12 or 24 volts. When used with the Sync•Circuit Module, 12-volt rated notification appliance circuit outputs shall operate between 9 and 17.5 volts; 24-volt rated notification appliance circuit outputs shall operate between 17 and 33 volts. Indoor SpectrAlert Advance products shall operate between 32°F and 120°F (0°C and 49°C) from a regulated DC, or full-wave-rectified, unfiltered power supply. Strobes and horn/strobes shall have field-selectable candela settings including 15, 15/75, 30, 75, 95, 110, 115, 135, 150, 177, 185.

STROBE

The strobe shall be a System Sensor SpectrAlert Advance Model _____ listed to UL 1971 and shall be approved for fire protective service. The strobe shall be wired as a primary-signaling notification appliance and comply with the Americans with Disabilities Act requirements for visible signaling appliances, flashing at 1 Hz over the strobe's entire operating voltage range. The strobe light shall consist of a xenon flash tube and associated lens/reflector system.

HORN/STROBE COMBINATION

The horn/strobe shall be a System Sensor SpectrAlert Advance Model _____ listed to UL 1971 and UL 464 and shall be approved for fire protective service. The horn/strobe shall be wired as a primary-signaling notification appliance and comply with the Americans with Disabilities Act requirements for visible signaling appliances, flashing at 1 Hz over the strobe's entire operating voltage range. The strobe light shall consist of a xenon flash tube and associated lens/reflector system. The horn shall have three audibility options and an option to switch between a Temporal 3 pattern and a Non-Temporal (continuous) pattern. These options are set by a multiple position switch. On four-wire products, the strobe shall be powered independently of the sounder. The horn on horn/strobe models shall operate on a coded or non-coded power supply.

OUTDOOR PRODUCTS

SpectrAlert Advance outdoor horns, strobes and horn/strobes shall be listed for outdoor use by UL and shall operate between -40°F and 151°F (-40°C and 66°C). The products shall be listed for use with a System Sensor outdoor/weather-proof backbox with half-inch and three-fourths-inch conduit entries.

SYNCHRONIZATION MODULE

The module shall be a System Sensor Sync•Circuit MDL3R or MDL3W listed to UL 464 and shall be approved for fire protective service. The module shall synchronize SpectrAlert strobes at 1 Hz and horns at Temporal 3. Also, while operating the strobes, the module shall silence the horns on horn/strobe models over a single pair of wires. The module shall mount to a 4.688" x 4.688" x 2.125" (11.906 x 11.906 x 5.398 cm) backbox. The module shall also control two Style Y (class B) circuits or one Style Z (Class A) circuit. The module shall synchronize multiple zones. Daisy-chaining two or more synchronization modules together will synchronize all the zones they control. The module shall not operate on a coded power supply.

Strobe Current Draw, UL Maximum (mA RMS)

Candela	8 – 17.5 V		16 – 33 V		
	DC	FWR	DC	FWR	
Standard Candela Range	15	123	128	66	71
	15/75	142	148	77	81
	30	NA	N/A	94	96
	75	NA	NA	158	153
	95	NA	NA	181	176
	110	NA	NA	202	195
	115	NA	NA	210	205
High Candela Range	135	NA	NA	228	207
	150	NA	NA	246	220
	177	NA	NA	281	251
	185	NA	NA	286	258

Operating Specifications

- **Standard operating temperature:** 32°F to 120°F (0°C to 49°C).
- **K Series operating temperature:** -40°F to 151°F (-40°C to 66°C).
- **Humidity range:** 10% to 93% non-condensing (indoor products).
- **Strobe flash rate:** 1 flash per second.
- **Nominal voltage:** regulated 12 VDC/FWR or regulated 24 VDC/FWR. **NOTE:** Full Wave Rectified (FWR) voltage is a non-regulated, time-varying power source that is used on some power supply and panel outputs.
- **Operating voltage range:** 8 V to 17.5 V (12 V nominal); or 16 V to 33 V (24 V nominal). **NOTE:** P, S, PC, and SC products will operate at 12 V nominal only for 15 cd and 15/75 cd.
- **Input terminal wire gauge:** 12 to 18 AWG (3.31 to 0.821 mm²).
- **Ceiling-mount dimensions (including lens):** 6.8" diameter x 2.5" deep (17.3 cm diameter x 6.4 cm deep).
- **Wall-mount dimensions (including lens):** 5.6" H x 4.7" W x 2.5" D (14.2 cm H x 11.9 cm W x 6.4 cm D).
- **Horn dimensions:** 5.6" H x 4.7" W x 1.3" D (14.2 cm H x 11.9 cm W x 3.3 cm D).

Agency Listings and Approvals

The listings and approvals below apply to SpectrAlert Advance Selectable Output Notification Devices. In some cases, certain modules may not be listed by certain approval agencies, or listing may be in process. Consult factory for latest listing status.

- **UL Listed:** S4011 (HR__, HW__, P2__, P4__, PC2__, PC4__ models); S5512 (models SCR, SCRH, SCW, SCWH, SR, SRH, SW, SWH); S3593 (SCRHK, SCRK, SRHK, SRK).
- **ULC Listed:** S4011 (HRA, HRKA); S5512 (typically "A" models, with exception of outdoor strobes). See Canadian data sheet for listings and specifications.
- **FM approved**
- **MEA: 452-05-E**
- **CSFM: 7125-1653:0186** (SCR, SCRH, SCW, SCWH, SR, SRH, SW, SWH); **7300-1653:0188** (P2_, P4_, PC2_, PC4_ modules); **7135-1653:0189** (HR, HRK, HW); **7300-1653:0187** (SCRHK, SCRK, SRHK, SRK).

Horn Current Draw, UL Maximum (mA RMS)

Sound Pattern	dB	8 – 17.5 V		16 – 33 V	
		DC	FWR	DC	FWR
Temporal	High	57	55	69	75
Temporal	Medium	44	49	58	69
Temporal	Low	38	44	44	48
Non-temporal	High	57	56	69	75
Non-temporal	Medium	42	50	60	69
Non-temporal	Low	41	44	50	50
Coded	High	57	55	69	75
Coded	Medium	44	51	56	69
Coded	Low	40	46	52	50

Horn and Horn/Strobe Rotary Switch Setting

Setting	Repetition Rate	dB Level
1	Temporal horn	High
2	Temporal horn	Medium
3	Temporal horn	Low
4	Normal horn	High
5	Normal horn	Medium
6	Normal horn	Low
7*	Externally coded	High
8*	Externally coded	Medium
9*	Externally coded	Low

***NOTE:** Settings 7, 8, and 9 are not available on 2-wire horn/strobe.

Horn and Horn/Strobe Output (dBA)

Switch Position	Sound Pattern	dB	8 – 17.5 V		16 – 33 V	
			DC	FW R	DC	FW R
1	Temporal	High	78	78	84	84
2	Temporal	Medium	74	74	80	80
3	Temporal	Low	71	73	76	76
4	Non-temporal	High	82	82	88	88
5	Non-temporal	Medium	78	78	85	85
6	Non-temporal	Low	75	75	81	81
7*	Coded	High	82	82	88	88
8*	Coded	Medium	78	78	85	85
9*	Coded	Low	75	75	81	81

***NOTE:** Settings 7, 8, and 9 are not available on 2-wire horn/strobe.

Two-Wire Horn/Strobe, **STANDARD** Candela Range (15 – 115 cd), UL Maximum Current Draw (mA RMS)

Input, Sound Pattern, dB Level	8 – 17.5 V		16 – 33 V						
	15	15/75	15	15/75	30	75	95	110	115
DC Input, Temporal, High	137	147	79	90	107	176	194	212	218
DC Input, Temporal, Medium	132	144	69	80	97	157	182	201	210
DC Input, Temporal, Low	132	143	66	77	93	154	179	198	207
DC Input, Non-temporal, High	141	152	91	100	116	176	201	221	229
DC Input, Non-temporal, Medium	133	145	75	85	102	163	187	207	216
DC Input, Non-temporal, Low	131	144	68	79	96	156	182	201	210
FWR Input, Temporal, High	136	155	88	97	112	168	190	210	218
FWR Input, Temporal, Medium	129	152	78	88	103	160	184	202	206
FWR Input, Temporal, Low	129	151	76	86	101	160	184	194	201
FWR Input, Non-temporal, High	142	161	103	112	126	181	203	221	229
FWR Input, Non-temporal, Medium	134	155	85	95	110	166	189	208	216
FWR Input, Non-temporal, Low	132	154	80	90	105	161	184	202	211

Two-Wire Horn/Strobe, **HIGH** Candela Range (135 – 185 cd), UL Maximum Current Draw (mA RMS)

DC Input	16 – 33 V				FWR Input	16 – 33 V			
	135	150	177	185		135	150	177	185
DC, Temporal, High	245	259	290	297	FWR, Temporal, High	215	231	258	265
DC, Temporal, Medium	235	253	288	297	FWR, Temporal, Medium	209	224	250	258
DC, Temporal, Low	232	251	282	292	FWR, Temporal, Low	207	221	248	256
DC, Non-temporal, High	255	270	303	309	FWR, Non-temporal, High	233	248	275	281
DC, Non-temporal, Medium	242	259	293	299	FWR, Non-temporal, Medium	219	232	262	267
DC, Non-temporal, Low	238	254	291	295	FWR, Non-temporal, Low	214	229	256	262

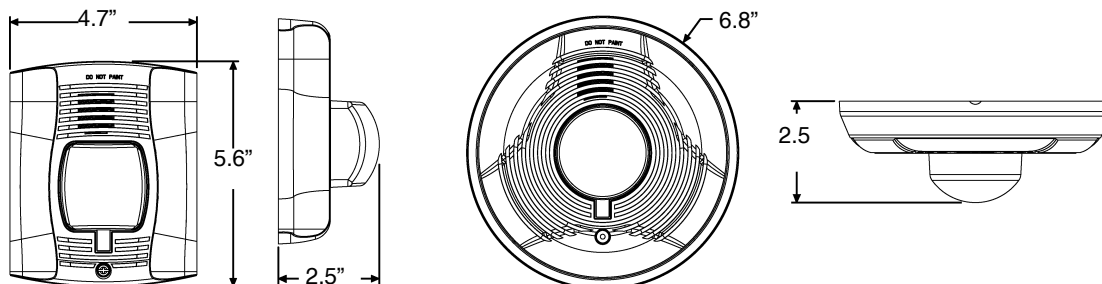

7087dim12009.tif

Ordering Information

Model	Description	Model	Description
WALL HORN/STROBES		CEILING HORN/STROBES	
P2R	2-wire horn/strobe, standard cd, red.	PC2R	2-wire horn/strobe, standard cd, red.
P2RH	2-wire horn/strobe, high cd, red.	PC2RH	2-wire horn/strobe, high cd, red.
P2RK	2-wire horn/strobe, standard cd, red, outdoor.	PC2RK	2-wire horn/strobe, standard cd, red, outdoor.
P2RHK	2-wire horn/strobe, high cd, red, outdoor.	PC2RHK	2-wire horn/strobe, high cd, red, outdoor.
P2W	2-wire horn/strobe, standard cd, white.	PC2W	2-wire horn/strobe, standard cd, white.
P2WH	2-wire horn/strobe, high cd, white.	PC2WH	2-wire horn/strobe, high cd, white.
P4R	4-wire horn/strobe, standard cd, red.	PC4R	4-wire horn/strobe, standard cd, red.
P4RH	4-wire horn/strobe, high cd, red.	PC4RH	4-wire horn/strobe, high cd, red.
P4RK	4-wire horn/strobe, standard cd, red, outdoor.	PC4RK	4-wire horn/strobe, standard cd, red, outdoor.
P4RHK	4-wire horn/strobe, high cd, red, outdoor.	PC4RHK	4-wire horn/strobe, high cd, red, outdoor.
P4W	4-wire horn/strobe, standard cd, white.	PC4W	4-wire horn/strobe, standard cd, white.
P4WH	4-wire horn/strobe, high cd, white.	PC4WH	4-wire horn/strobe, high cd, white.
WALL STROBES		CEILING STROBES	
SR	Strobe, standard cd, red.	SCR	Strobe, standard cd, red.
SRH	Strobe, high cd, red.	SCRH	Strobe, high cd, red.
SRK	Strobe, standard cd, red, outdoor.	SCRK	Strobe, standard cd, red, outdoor.
SRHK	Strobe, high cd, red, outdoor.	SCRHK	Strobe, high cd, red, outdoor.
SW	Strobe, standard cd, white.	SCW	Strobe, standard cd, white.
SWH	Strobe, high cd, white.	SCWH	Strobe, high cd, white.
ACCESSORIES		HORNS	
BBS-2A	Backbox skirt, wall, red.	HR	Horn, red.
BBSW-2A	Backbox skirt, wall, white.	HRK	Horn, red, outdoor.
BBSC-2A	Backbox skirt, ceiling, red.	HW	Horn, white.
BBSCW-2A	Backbox skirt, ceiling, white.	ACCESSORIES, continued	
SA-WBB	Weatherproof backbox, wall.	TR-HS	Trim Ring, wall, red, package of 5
SA-WBBC	Weatherproof backbox, ceiling.	TRW-HS	Trim Ring, wall, white, package of 5
WTP	Weatherproof, flush mount plate, red	TRC-HS	Trim Ring, ceiling, red, package of 5
WTPW	Weatherproof, flush mount plate, white	TRCW-HS	Trim Ring, ceiling, white, package of 5
<p>NOTE: "High cd" refers to strobes that include 135, 150, 177, and 185 candela settings. "Standard cd" refers to strobes that include 15, 15/75, 30, 75, 95, 110, and 115 candela settings.</p> <p>NOTE: For strobes and horn/strobes, add suffix "F" for French or "B" for Bilingual.</p> <p>NOTE: All outdoor models ("K(A)" suffix) include a plastic weatherproof backbox.</p> <p>NOTE: Add "-R" to models for weatherproof replacement device (no back box included). Only for use with weatherproof outdoor flush mounting plate, WTP and WTPW.</p> <p>NOTE: Add "P" to model for plain housing. (No "FIRE" marking on cover.)</p>			

SyncCircuit™ is a trademark and NOTIFIER® and SpectraAlert® are registered trademarks of Honeywell International Inc.
 ©2011 by Honeywell International Inc. All rights reserved. Unauthorized use of this document is strictly prohibited.



This document is not intended to be used for installation purposes.
 We try to keep our product information up-to-date and accurate.
 We cannot cover all specific applications or anticipate all requirements.
 All specifications are subject to change without notice.

For more information, contact Notifier. Phone: (203) 484-7161, FAX: (203) 484-7118.
www.notifier.com

7788F/7744F Series

Wireless Fire Alarm Communicators for AES-IntelliNet

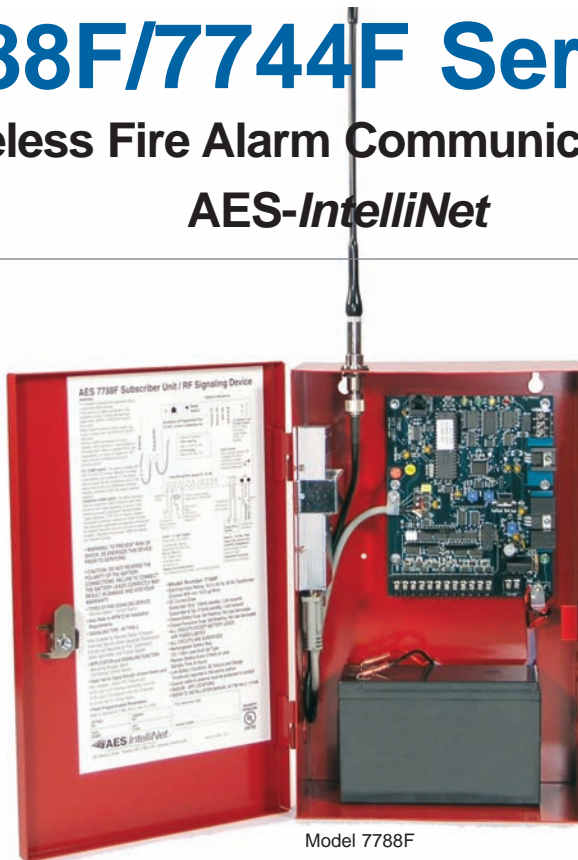

Features – All models

- UL Listed commercial fire alarm applications.
- Meets NFPA 72 requirements
- Direct reporting to AES receiver across IntelliNet wireless mesh network
- Each Subscriber acts as transmitter/receiver/repeater
- Simple and fast activation on network
- On board status LEDs for easy set up
- 8 programmable zone inputs – 7788F
- 4 programmable zone inputs and 4 reverse polarity inputs – 7744F
- Easy programming via AES handheld programmer or PC
- Rugged metal housing ideal for any commercial fire alarm application

Models 7788F/7744F-ULP with IntelliPro Fire also includes

- IntelliPro Fire transmits full alarm data from virtually any fire alarm panel digital communicator
- Alarm format support for Contact ID, Pulse, or Bosch Modem IIe or Modem IIIa2
- Easy installation in AES subscriber
- Operates in applications with or without a phone line

Advanced Wireless Alarm Monitoring

The AES-IntelliNet mesh radio network offers unmatched reliability and speed in delivering wireless alarm signals to a central station without third party fees or reliance on networks owned by companies outside the security and fire alarm industry. AES-7788F/7744F Series Smart Subscriber Transceivers provide the wireless communication link between the fire alarm panel and the central station receiver. The 7788F/7744F Series is ideal for most commercial fire alarm applications. Each 7788F/7744F Series Subscriber is housed in a full sized, red, locked, steel cabinet and supports a range of alarm panel inputs including EOL fire, EOL supervised, and direct voltage from the panel (non-fire applications).

Supervised Operation

AES Smart Subscribers offer fully supervised operation that includes monitoring of operating power (both primary AC power and battery backup) and the connection to the radio network. Each Subscriber “checks in” with the AES central station receiver at least once every 24 hours. The supervision check in time can be set for as often as once per minute and, because the central station owns the wireless network, there is no additional cost for air time to transmit supervisory signals.

Full Data Reporting from Alarm Panel Digital Dialer

Models 7788F-ULP and 7744F-ULP come equipped with an IntelliPro Fire Full Data Module (AES-7794) which enables reporting of full alarm data captured from the fire alarm panel's digital communicator. IntelliPro Fire supports most alarm communication formats including Contact ID, Pulse, as well as Bosch Modem IIe and Modem IIIa2.



Wireless mesh networking is an innovative technology adopted by many industries with applications that need to communicate data over a large geographic area with a high level of reliability at a low total cost of ownership.

The advanced design and 2-way communications capability provides easy installation, expansion, and management when compared to alternative communication methods, both wired and wireless.

7788F/7744F Series



Technical Specifications

7788F/7744F Series Subscribers

Dimensions

- 13.25"H x 8.5"W x 4.3"D
(34cm H x 21.5cm W x 11cm D)

Weight

- Approx. 7 pounds (3.2 kilograms), excludes battery.

Radio Frequency

- Standard Frequency Range: 450-470MHz (others available)
- Output Power - 2 Watts (others available)

Antenna

- Included 2.5 db tamper resistant antenna mounts on enclosure
- Multiple remote antenna options available

Power Input

- 16.5VAC, 40VA (transformer not included)

Backup Battery

- Will charge 12V battery up to 7.5 AH. Requires 12VDC 7.5 AH battery for UL 864.

Alarm Signal Inputs (subscriber)

- 7788F – 8 individually programmable zones
- 7744F - 4 individually programmable zones and 4 reverse polarity inputs

UL Standards

- UL 864 Edition 9 – Standard for Control Units and Accessories for Fire Alarm Systems
- UL 365 – Standard for Police Station Connected Burglar Alarm Units and Systems
- UL 1681 – Standard for Central Station Burglar Alarm Units

Antenna Cut / Communication

Trouble Output

- Form C relay; fail secure; rated for 24 VDC 1A resistive

Reset Button

- Located on main circuit board.

Operating Temperature

- 0° to 50° C (32° to 122°F)

Storage Temperature

- -10° to 60° C (14° to 140°F)

Relative Humidity

- 0 to 85% RHC, Non Condensing

AES-7794 IntelliPro Fire

Input / Output Connections

- RJ11 connection to AES subscriber for module data and power
- RJ11 connector for Handheld Programmer/PC programming
- RJ31X Telco connections - T and R both in and out via terminal strip and RJ45
- Alarm Panel digital communicator T and R both in and out via terminal strip and RJ45
- Trouble output: Form C relay detects if Subscriber is off the network

Alarm Formats

- Support for Contact ID and Pulse formats as well as Modem IIe and Modem IIIa2 converted to CID

Size

- 2.8 x 5.0 inches (7.1cm x 12.7cm)

Power Requirements

- 12 VDC nominal - primary and backup power provided by the AES 7788F/7744F or other Subscriber

How to Order

Model	Description
7744F	4 Zone Fire Alarm Subscriber with 4 reverse polarity inputs
7744F-ULP	7744F Fire Alarm Subscriber with IntelliPro Fire full data module
7788F	8 Zone Fire Alarm Subscriber
7788F-ULP	7788F Fire Alarm Subscriber with IntelliPro Fire full data module

Optional Accessories

7041E	Subscriber Handheld Programmer
7794	IntelliPro Fire Full Data Module



AES-IntelliNet™ is the industry leader in delivering high quality wireless mesh networks to the fire and security industry in commercial, corporate, government, and educational applications with its broad line of products and advanced network management tools. Users of AES-IntelliNet networks have gained significant revenue, communications, and cost advantages while meeting the high standards of reliability required for the fire and security industry. AES-IntelliNet alarm monitoring systems are deployed at hundreds of thousands of locations in over 150 countries.



For more information

Call 800-AES-NETS (800-237-6387)

AES Corporation | 285 Newbury Street | Peabody, MA 01960 USA

Tel. +1 978-535-7310 | Fax +1 978-535-7313 | Email info@aes-intellinet.com

Web www.aes-intellinet.com

Copyright 2011 AES Corporation
AES-IntelliNet is a registered trademark
of AES Corporation

7788F-7744F/9/7/11R3

Multi-Voltage Conventional Relays



Miscellaneous

General

Notifier's multi-voltage conventional relays are used for high-current switching applications such as fan and damper assembly control, door control, air handling unit controls, and other types of system interfacing.

The R-10T(A)/20T(A) and R-14T(A)/R-24T(A) models are multi-voltage relays with terminal strip field wiring connections, mounting track and hardware. The R-10T(A) is a single FORM-C (SPDT) relay with a red activation LED, and the R-14T(A) is a 4-gang 1 FORM-C (SPDT) relay with 4 red activation LEDs. The R-20T(A) is a single 2 FORM-C (DPDT) relay with red activation LED, and the R-24T(A) is a 4-gang 2 FORM-C (DPDT) relay with 4 red activation LEDs.

The R-10E(A)/R-20E(A) and R-14E(A)/R-24E(A) are similar to the T series track mount relays, but they are mounted into a steel enclosure. The enclosure has a removable front cover that provides easy access and a LED viewing hole on the top of the cover.

PR-1(A)/PR-2(A)/PR-3(A) are epoxy encapsulated multi-voltage relays. They are single pole double throw relays that use a red LED as a visible indication of relay coil energization. PR-3 is identical to PR-2 except it has an extra pair of wires for redundant power input.

Model EOLR-1(A) is an epoxy encapsulated single pole single throw, normally open relay that can be used as an end of line device in fire alarm systems, e.g. to supervise power supplies.

Specifications

R-10T(A)/R-14T(A)/R-20T(A)/ R-24(A)T

Operating Voltage Range: 18-35 VDC, 18-35 VAC, 115 VAC, 230 VAC.

Operating Current: 23 mA @ 24 VDC, 59 mA @ 24 VAC, 150 mA @ 120 VAC, 180 mA @ 240 VAC [R-10T(A)/R-14T(A)].

40 mA DC max. @ 24 VDC, 24 VAC, 92 mA @ 24 VAC, 220 mA @ 120 VAC, 260 mA @ 240 VAC [R-20T(A)/R-24T(A)]

Humidity Range: 10% to 93% (non-condensing).

Dimensions: R-10T(A)/ R-20T(A): 2.5"L x 3.35"W x 1.2"H.

R-14T(A)/R-24T(A): 10"L x 3.35"W x 1.2"H.

Operating Temperature: -40° F to 158° F (-40°C to 70°C)

Contact Ratings: 24 VDC: 7A with L/R = 5 mS.
120 VAC: 10 A.
120 VAC: 1/6 HP.
230 VAC: 7 A.

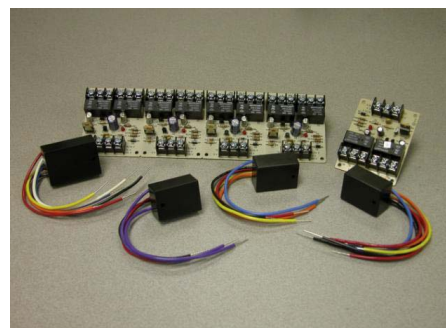

Multi-Voltage Conventional Relays

7015dn015g101

R-10E(A)/ R-14E(A)/R-20E(A)/ R-24E(A)

Operating Voltage Range: 18-35 VDC, 18-35 VAC, 115 VAC, 230 VAC.

Operating Current: 23 mA DC max. @ 24 V, 59 mA @ 24 VAC, 150 mA @ 120 VAC, 180 mA @ 240 VAC [R-10E(A)/R-14E(A)].

-40 mA DC max. @ 24 VDC, 24 VAC, 115 VAC, 230 VAC (R-20E/R-24E).

Humidity Range: 10% to 93% (non-condensing).

Dimensions: R-10E(A)/R-20E(A): 5.1"L x 3.75"W x 2.5"H.

R-14E(A)/R-24E(A): 11"L x 5.3"W x 2.5"H.

Operating Temperature: -40° F to 158° F (-40° C to 70° C).

Contact Ratings: 24 VDC: 7 A with L/R = 5mS.
120 VAC: 10 A.
120 VAC: 1/6 HP.
230 VAC: 7 A.

PR-1(A)

Operating Voltage Range: 18-35 VDC, 18-35 VAC, 120 VAC.

Operating Current: 15 mA DC max. @ 24 VDC, 24 VAC, 120VAC.

Humidity Range: 10% to 93% RH.

Dimensions: 0.87" H x 2.01" W x 1.42" D.

Operating Temperature: -40° F to 158° F (-40° C to 70° C).

Contact Ratings: 24 VDC: 7 A with LR = 5 mS.
120 VAC: 7 A max. (0.35 PF).
250 VAC: 10 A resistive.
30 VDC: 10 A resistive.

Wire Length: 8" minimum.

PR-2(A)/PR-3(A)

Operating Voltage Range:	10 to 40 VDC.
Operating Current:	30 mA DC max.
Humidity Range:	10% to 93% RH.
Dimensions:	0.91" H x 1.65" W x 1.22" D.
Operating Temperature:	-40° F to 158° F (-40° C to 70° C).
Contact Ratings:	120 VAC: 10 A (resistive load). 120 VAC: 7 A max. (0.35 PF). 250 VAC: 10 A max. (resistive load). 30 VDC: 10 A max. (resistive load).
Wire Length:	8" minimum.

EOLR-1(A)

Operating Voltage Range:	9 to 40 VDC.
Operating Current:	20 mA DC max.
Humidity Range:	10% to 93% RH.
Operating Temperature:	-22° F to 140° F (-30° C to 60° C).
Contact Ratings:	120 VAC: 0.5 A max. (resistive load). 30 VDC: 3 A max. (resistive load).
Wire Length:	8" minimum.

Agency Listings and Approvals

In some cases, certain modules may not be listed by certain approval agencies, or listing may be in process. Consult factory for latest listing status.

- UL/ULC Listed: S3705
- ULC Listed: CS669
- MEA: 419-04-E
- CSFM: 7300-1653:173

PRODUCT LINE INFORMATION

NOTE: "A" suffix indicates ULC listed model.

PR-1(A): Epoxy encapsulated single pull double throw (SPDT) relay. It also uses a red LED as a visible indication of relay coil energization with pigtailed.

PR-2(A): Epoxy encapsulated single pull double throw (SPDT) activated by 10 to 40 VDC. It uses a red LED as a visible indication of relay coil energization with pigtailed.

PR-3(A): Epoxy encapsulated single pull double throw (SPDT) activated by 10 to 40 VDC. It contains an additional black and red wire for redundant power input with pigtailed.

EOLR-1(A): Epoxy encapsulated single pull single throw (SPST) normally open relay that is activated by 9 to 40 VDC. This relay can be used as an end of line device in fire alarm systems, e.g., to supervise power supplies.

R-10T(A): Single (SPDT) relay with a red activation LED.

R-14T(A): 4-gang (SPDT) relay with 4 red activation LEDs.

R-20T(A): Single (DPDT) relay with a red activation LED.

R-24T(A): 4-gang (DPDT) relay with 4 red activation LEDs.

The R-10E(A)/R-20E(A) and R-14E(A)/R-24E(A) are similar to the T series track mount relays, but they are mounted into a steel enclosure. The enclosure has a removable front cover that provides easy access and a LED viewing hole on the top of the cover.

R-10E(A): Single (SPDT) relay mounted into a steel enclosure, 1 red activation LED.

R-14E(A): 4-gang (SPDT) relay mounted into a steel enclosure, 4 red activation LEDs.

R-20E(A): Single (DPDT) relay mounted into a steel enclosure, 1 red activation LED.

R-24E(A): 4-gang (DPDT) relay mounted into a steel enclosure, 4 red activation LEDs.

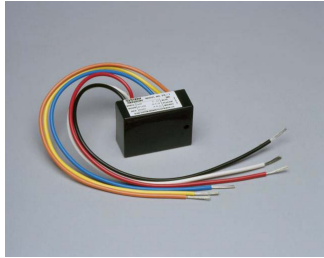

7015pr1.jpg

PR-1(A)



7015pr2.jpg

PR-2(A)

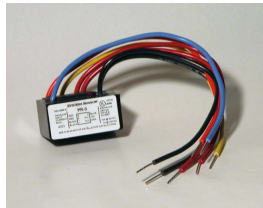

7015pr3.jpg

PR-3(A)

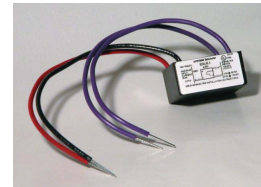

7015eolr1.jpg

EOLR-1(A)

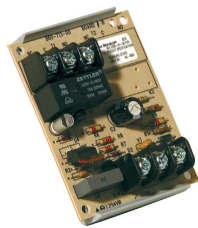

7015r10t.jpg

R-10T(A)

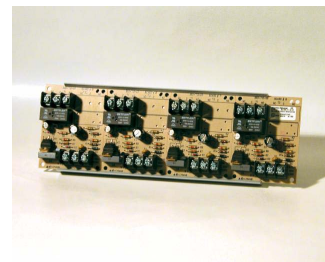

7015r14t.jpg

R-14T(A)

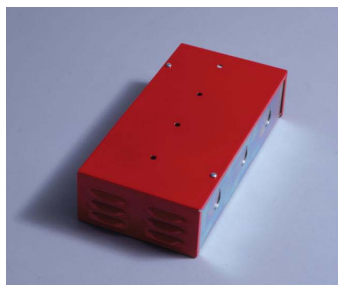

7015r20-24e.jpg

**R-20E(A) & R-24E(A)
Enclosures**

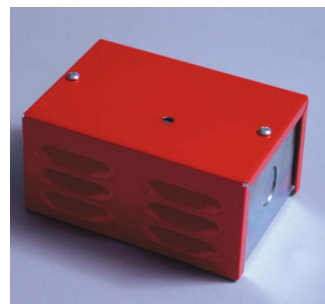

7015r10-14e.jpg

**R-10E(A) & R-14E(A)
Enclosures**

©2013 by Honeywell International Inc. All rights reserved. Unauthorized use of this document is strictly prohibited.



This document is not intended to be used for installation purposes.
We try to keep our product information up-to-date and accurate.
We cannot cover all specific applications or anticipate all requirements.
All specifications are subject to change without notice.

For more information, contact Notifier. Phone: (203) 484-7161, FAX: (203) 484-7118.
www.notifier.com

Photoelectric Smoke Alarm 120VAC Single/Multiple Station Smoke Alarm Applications

The Gentex GN-200 (120VAC) and GN-300 (120VAC/9VDC) Series photoelectric smoke alarms are designed for residential and commercial residential applications, including but not limited to, homes, apartments, hospitals, hotels and motels, in compliance with UL 217 and NFPA 72.

The GN-200 and GN-300 Series are engineered to virtually eliminate nuisance alarms and deliver outstanding performance wherever reliable fire and smoke protection is required.

The GN-300 Series is a 120VAC with a 9 VDC alkaline battery for back-up in the event building power is lost. The battery impedance is verified and the smoke alarm provides a low or missing battery warning. The battery drawer provides easy replacement without removing the unit from the wall or ceiling.

The Gentex GN-200 and GN-300 Series are provided with a push button test that simulates a 3.5% actual smoke condition in compliance with NFPA 72 and UL Standards.

Tandem connection capabilities up to 12 units is available on the GN-200 and GN-300 Series. The GN-200 and GN-300 Series have tandem capabilities with existing Gentex smoke alarms.

The GN-200 and GN-300 Series provides a continuous tone. The GN-203 and GN-303 Series provides a temporal 3 evacuation tone.

Standard Features

- GN-200 Series available in 120VAC
- GN-300 Series available in 120VAC with 9VDC battery back-up
- Horn frequency 3150 Hz (Nominal)
- Nominal 2.5% sensitivity
- Push button test feature
- On-site maintenance washing program
- GN-300 Series includes battery drawer on side of unit to allow for battery replacement without removing unit from wall or ceiling
- GN-300 Series includes low or missing battery indicator
- Quick-disconnect wiring harness
- Sure-Lock™ locking pin to detour alarm tampering
- Dust-Cover included to keep units dust free until occupancy
- 85dBA continuous solid-state piezo horn (GN-200 & GN-300 Models)
- Temporal 3 evacuation sounding device (GN-203 & GN-303 Models)
- Pulsing LED sensing chamber
- Insect Protected
- Easy Wash™ on site maintenance program
- Red LED pulses every 30 seconds, green LED verifies AC power
- Mounting hardware adapts to standard junction boxes
- Full tandem compatibility with existing Gentex smoke alarms.
- Mounting bracket allows mounting to textured ceilings

GN - 200 & GN - 300 SERIES



**Easy Wash™ -
On Site
Maintenance
Program**

Product Listings

SIGNALING



- CSFM # 7257-0569:138
- UL 217 Listed

Product Compliance

- NFPA 72
- IBC/IFC/IRC



GN-200 & GN-300 Series

Model Number	Part Number	Voltage	Continuous Piezo	Temporal 3 Piezo	Tandem up to 12 Units	9VDC Battery Back-Up
GN-200	917-0052-002	120VAC	●		●	
GN-203	917-0053-002	120VAC		●	●	
GN-300	917-0049-002	120VAC	●		●	●
GN-303	917-0050-002	120VAC		●	●	●

GN-200 & GN-300 Series Wiring Diagrams

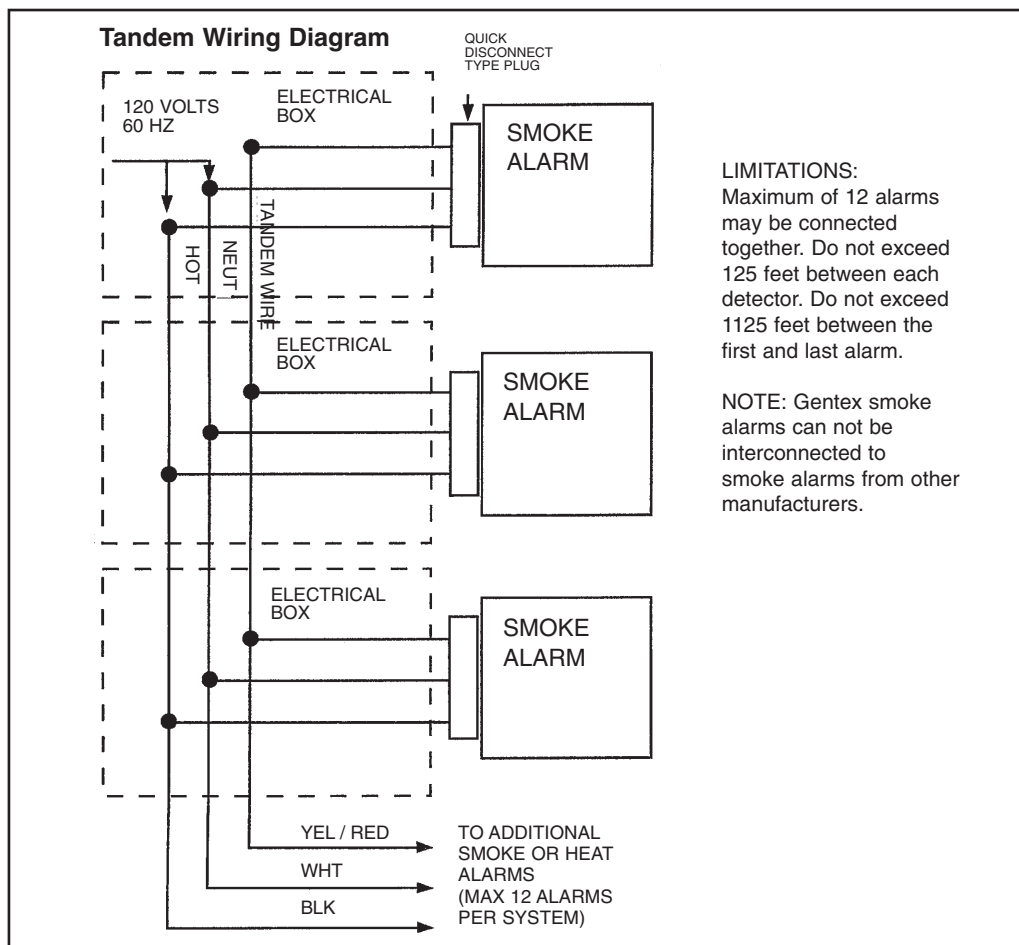

Electrical Specifications

Operating Voltage (GN-200 & GN-300 Series)	120 VAC, 60Hz
Operating Current037 amps
Operating Ambient Temp Range	40°F to 100°F
Alarm Horn Rating	85dBA at 10 ft.
Nominal Sensitivity	2.5% Obscuration
Size	Diameter: 6.0 in. OA (4.75 in. at Ceiling) Depth: 1.75 in.
Secondary Power Source (GN-300 & GN-303)	Duracell MN 1604 9VDC Alkaline Battery

Architect & Engineering Specifications

The Photoelectric Smoke alarm shall be a Gentex Model GN-200/GN-203/GN-300/GN-303 or approved equal which shall provide at least the following features and functions.

1. Nominal sensitivity shall be 2.5%.
2. The alarm shall utilize an infrared LED sensing circuit which pulses in 4 to 5 second intervals when subjected to smoke. After 2 consecutive pulses in smoke, the smoke alarm will activate.
3. The GN-300 Series smoke alarm shall have a Duracell MN 1604 9VDC alkaline battery as a back-up in the event building power is lost.
4. The 9 VDC battery impedance shall be verified by the circuit of the smoke alarm.
5. The smoke alarm shall provide an indicator when the battery is low in power or high impedance or is missing.
6. The sensing chamber shall be fully screened to prevent entrance of small insects, thus reducing the probability of false alarms.
7. A solid state piezo alarm rated at 85dBA at 10ft.
8. A visual LED monitor (status indicator) will slow pulse in normal operation and rapid pulse in alarm.
9. An easily accessible test button shall be provided. Push down on button for 5 seconds causing smoke alarm to go into alarm. If smoke alarm does not alarm, the smoke alarm is not working properly.
10. The smoke alarms shall have tandem interconnect capability of up to 12 units.
11. The smoke alarms shall have the capability to tandem with all Gentex interconnect capable smoke alarms including 7000/7003 Series, 9000/9003 Series, 710/713CS Series and 7109/7139CS Series.
12. Unit must be UL 217 listed for both wall and ceiling mount.
13. Unit shall be equipped with dust-cover to protect unit while construction is complete. Dust-cover must be removed prior to power being supplied to smoke alarm. If dust-cover is not removed operation of smoke alarm will be inhibited.
14. Unit shall be listed by Underwriters Laboratories, California State Fire Marshal (CSFM) and the Bureau of Standards and Appeals (NYC).

All equipment shall be completely factory assembled, wired and tested, and the contractor shall be prepared to submit a certified letter testifying to this condition. Alarms which do not meet all of the requirements of this specification will not be considered.

For complete product specifications, refer to product installation manual.

24 units per carton 24 pounds per carton

GN-200 & GN-300 SERIES

GENTEX
CORPORATION

Fire Protection Products Group • www.gentex.com
10985 Chicago Drive • Zeeland, Michigan 49464
616.392.7195 • 1.800.436.8391 • 616.392.4219 Fax

Gentex Corporation reserves the right to make changes to the product data sheet at their discretion.

Important Notice:

These materials have been prepared by Gentex Corporation ("Gentex") for informational purposes only, are necessarily summary, and are not purported to serve as legal advice and should not be used as such. Gentex makes no representations and warranties, express or implied, that these materials are complete and accurate, up-to-date, or in compliance with all relevant local, state and federal laws, regulations and rules. The materials do not address all legal considerations as there is inevitable uncertainty regarding interpretation of laws, regulations and rules and the application of such laws, regulations and rules to particular fact patterns. Each person's activities can differently affect the obligations that exist under applicable laws, regulations or rules. Therefore, these materials should be used only for informational purposes and should not be used as a substitute for seeking professional legal advice. Gentex will not be responsible for any action or failure to act in reliance upon the information contained in this material.

551-0052-02

 Printed on Recycled Paper



GENTEX CORPORATION

Combination Photoelectric Smoke and Carbon Monoxide Alarm

120VAC/9VDC Single/Multiple Station Smoke and CO Alarm

GN-503 SERIES

Applications

The GN-503 (120VAC/9VDC) Series of combination photoelectric smoke and electrochemical sensor carbon monoxide alarms are for use as evacuation devices in all dwelling units, including but not limited to homes, apartments, hospitals, hotels, motels and other commercial occupancies. The GN-503 Series is listed in compliance with ANSI/UL 217, ANSI/UL 2034, for installation per NFPA 720 and NFPA 72.

Available in three models, the GN-503 Series is engineered to virtually eliminate nuisance alarms and deliver outstanding performance wherever reliable smoke and CO protection is required. The GN-503F features one (1) set of Form A/Form C contacts that activate for smoke and/or CO events. **THE GN-503FF FEATURES TWO (2) SETS OF FORM A/ FORM C CONTACTS THAT ACTIVATE INDEPENDENTLY FOR SMOKE AND CO EVENTS.** Both the GN-503F and GN-503FF provide a connection to a protected premises alarm system to provide a supervisory/trouble signal.

The GN-503 Series is provided with a 9VDC alkaline battery for electrical back-up in the event building power is lost. The battery impedance is verified and the alarm provides a low or missing battery warning. The battery drawer provides easy replacement without removing the unit from the wall or ceiling.

The GN-503 Series is designed with a self test feature that quickly notifies if the alarm is functioning properly or needs attention (signified by a series of chirps) by simply pressing the test button. The functionality tests that the smoke/CO alarm is operating properly (signified by going into alarm). The self and functionality tests are in compliance with NFPA 72, NFPA 720 and ANSI/UL Standards.

The GN-503 Series provides a temporal 3 evacuation tone for smoke alarm annunciation and all units provide a temporal 4 tone for CO alarm annunciation. Per NFPA 720, the temporal 3 evacuation tone for smoke alarm will take precedence over the temporal 4 tone for CO alarm.



Product Listings

SIGNALING



LISTED



- ANSI/UL 217 and ANSI/UL 2034 Listed
- CSFM # 5276-0569:144

Product Compliance



- NFPA 72 and NFPA 720
- IBC/IFC/IRC
- City & State Ordinances/Laws/Regulations
- Quality Management System is certified to: ISO 9001:2008

Standard Product Features

- GN-503 available in 120VAC with 9VDC battery back-up
- Horn frequency 3100 Hz (nominal)
- Meets sensitivity requirements of ANSI/UL 2034
- F Model: One (1) set of Form A/Form C contacts that activate for smoke and/or CO events
- FF Model: Two (2) sets of Form A/Form C contacts that activate independently for smoke and CO events
- Relay contacts operate on battery back-up
- Push button self test feature
- Push button functional test feature
- Quick-disconnect wiring harness
- Non-latching (self restoring) alarm
- Fully insect protected
- Red LED pulses every 30 seconds, green LED for AC power on

- Mounting hardware adapts to standard junction boxes, including but not limited to 4x4x2-1/8 octagon
- Dust cover to prevent contamination during installation
- Low or missing battery indicator
- 1 year warranty from date of purchase
- 5 year limited warranty on CO sensor

Additional Smoke Alarm Features

- Photoelectric smoke sensing technology
- Temporal 3 evacuation sounding pattern for smoke annunciation
- Nominal 2.5% sensitivity (smoke)
- Solid state red LED to indicate smoke presence

Additional CO Alarm Features

- Electrochemical sensor
- Temporal 4 sounding pattern for CO annunciation
- End of life signal indicates CO sensor has reached depletion state and unit must be replaced

GN-503 Series Combination Smoke/CO Alarm

Model Number	Voltage	9VDC Battery Back-Up	One (1) Set Form A/ Form C Relay Contacts	Two (2) Sets Form A/ Form C Relay Contacts
GN-503	120VAC	●		
GN-503F	120VAC	●	●	
GN-503FF	120VAC	●		●

GN-503 AND GN-503F Wiring Diagrams

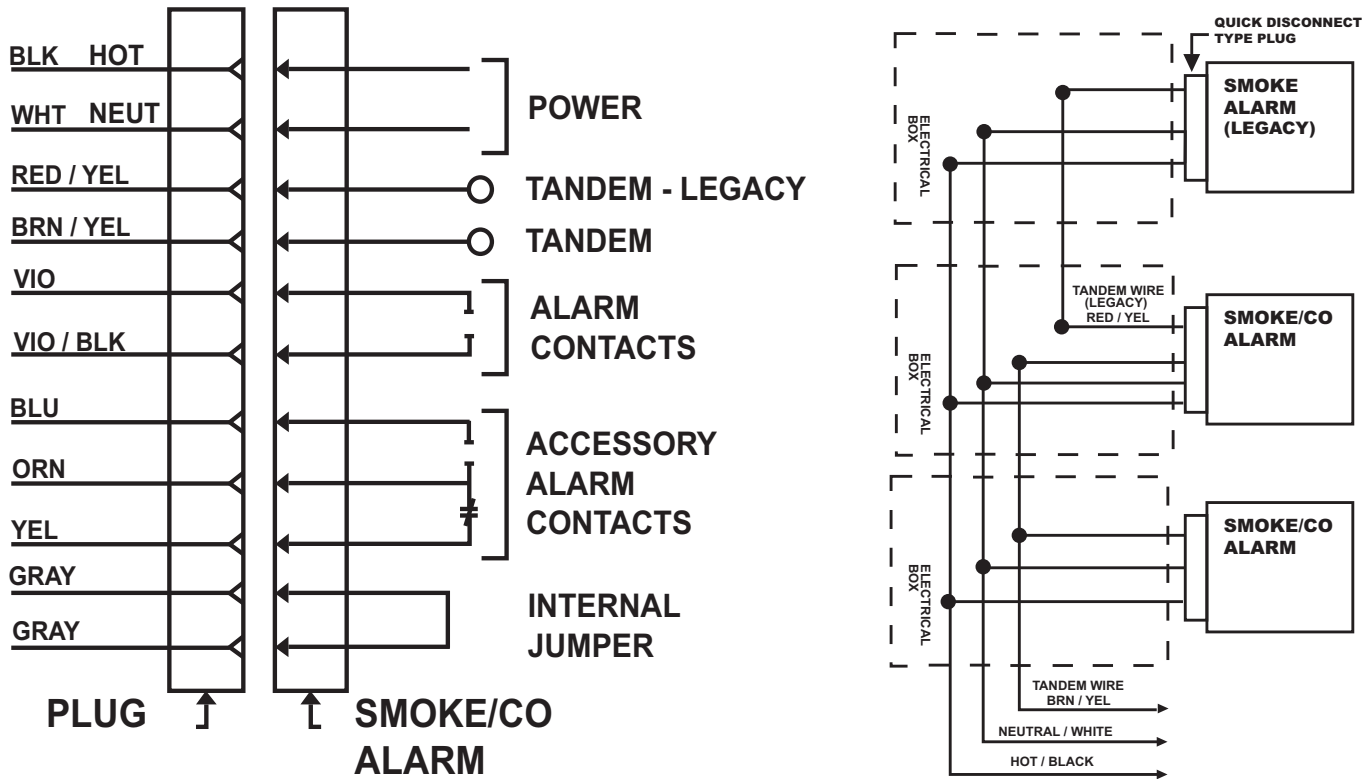

GN-503/GN-503F ADDITIONAL PRODUCT INFORMATION

THE GN-503F AND GN-503FF PRODUCT WIRING HARNESS IS NOT INTERCHANGEABLE. THE GN-503F AND GN-503FF MUST USE PROPER WIRING HARNESS. PRODUCT WILL NOT FUNCTION IF INCORRECT HARNESS IS USED.

- DO NOT connect Gentex alarms to other manufacturers' alarms.
- Per NFPA 72, a maximum of 18 compatible smoke, heat, CO and/or combination smoke/CO alarms may be interconnected. No more than 12 of the 18 can be smoke alarms.
- All units connected in tandem MUST get their power from the same circuit, that is, all smoke alarms in tandem must be controlled by the same fuse or circuit breaker.

NOTICE: PER NFPA 72, A MAXIMUM OF 12 SMOKE/CO ALARMS OF GN-503 WITH THE RELAY OPTION (F) MAY BE TANDEM INTERCONNECTED.

The GN-503/GN-503F may be tandem interconnected with other Gentex tandem capable smoke alarms, CO alarms or smoke/CO alarms. To interconnect with Gentex 9000 Series, 7000 Series, 710CS Series, 7109CS Series, GN-200 Series & GN-300 Series the LEGACY TANDEM WIRE must be used. Refer to installation manual for detailed information.

CAUTION: RED/YELLOW & BROWN/YELLOW wire to be capped when not in use. This wire is for tandem connection only. Do not connect to any other circuit.

- If a GN-503 Series or CO1209 Series unit is annunciating for a CO event, legacy products that are tandem interconnected will not activate and will remain silent.
- If smoke alarm portion of device goes into alarm, all smoke alarms, CO alarms or combination smoke/CO alarms tandem wired will sound smoke alarm warning.
- When both smoke and CO conditions are present, smoke condition will have priority and alarm will sound smoke annunciation.

USING THE GENTEX GN-503FF COMBINATION SMOKE AND CARBON MONOXIDE ALARM ALLOWS THE ABILITY TO:

- Interface with a FACP Panel
- Interface with NAC Circuits

GN-503FF Wiring Diagrams

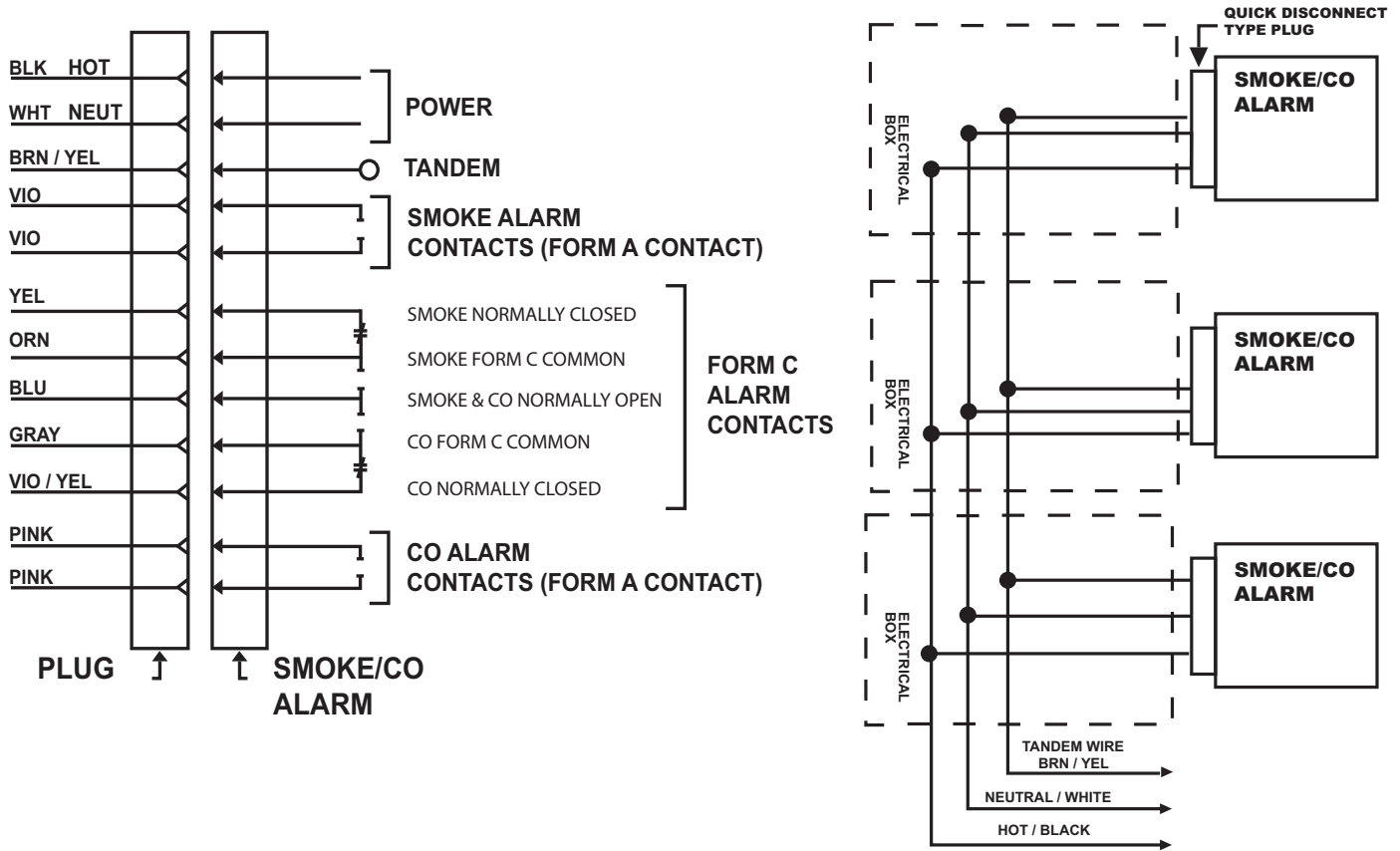

GN-503FF ADDITIONAL PRODUCT INFORMATION

Use brown/yellow wire to tandem interconnect GN-503FF alarms to additional GN-503 Series, S1209 Series and CO1209 Series.

NOTICE: THE GN-503FF IS ONLY CAPABLE OF TANDEM INTERCONNECT WITH GN-503 SERIES, CO1209 SERIES AND S1209 SERIES.

THE GN-503F AND GN-503FF PRODUCT WIRING HARNESS IS NOT INTERCHANGEABLE. THE GN-503F AND GN-503FF MUST USE PROPER WIRING HARNESS. PRODUCT WILL NOT FUNCTION IF INCORRECT HARNESS IS USED.

- DO NOT connect Gentex alarms to other manufacturers' alarms.
- Per NFPA 72, a maximum of 18 compatible smoke, heat, CO and/or combination smoke/CO alarms may be interconnected. No more than 12 of the 18 can be smoke alarms.
- All units connected in tandem MUST get their power from the same circuit, that is, all smoke alarms in tandem must be controlled by the same fuse or circuit breaker.

NOTICE: PER NFPA 72, A MAXIMUM OF 12 SMOKE/CO ALARMS OF GN-503 WITH THE RELAY OPTION (FF) MAY BE TANDEM INTERCONNECTED.

CAUTION: BROWN/YELLOW wire to be capped when not in use. This wire is for tandem connection only. Do not connect to any other circuit.

- If smoke alarm portion of device goes into alarm, all smoke alarms, CO alarms or combination smoke/CO alarms tandem wired will sound smoke alarm warning.
- When both smoke and CO conditions are present, smoke condition will have priority and alarm will sound smoke annunciation.

GN-503 SERIES

Electrical Specifications

Operating Voltage	120VAC, 60Hz
Operating Current045 amps
Operating Current (Relay Options)070 amps
Operating Ambient Temp Range	40°F to 100°F (4.4°C-38°C)
Alarm Horn Rating	85dBA at 10 feet (3.048 m)
Auxiliary Relay (GN-503F)	1 Form A & 1 Form C (0.5 amp)
Auxiliary Relay (GN-503FF)	2 Form A & 2 Form C (0.3 amp)
Size	Diameter at base: 5.75 in. (14.605 cm)
.....	Overall diameter 6.25 in. (16.51 cm)
.....	Depth: 1.8 in. (4.572 cm)
Secondary Power Source	Alkaline 9VDC battery (Duracell® MN 1604)
CO Sensing Cell	Electrochemical Cell

Architect & Engineering Specifications

The combination photoelectric smoke and carbon monoxide alarm shall be a Gentex Model GN-503/GN-503F/GN-503FF or approved equal which shall provide at least the following features and functions:

- Nominal smoke sensitivity shall be 2.5%.
- The smoke alarm portion of device shall utilize an infrared LED sensing circuit which pulses in 4 to 5 second intervals when subjected to smoke. After 2 consecutive pulses in smoke, the alarm shall activate.
- The CO alarm shall utilize an electrochemical sensing element with a minimum 5-year life.
- The carbon monoxide alarm portion of device is adjusted not to detect CO levels below 30 PPM and will not alarm when exposed to constant levels of 30 PPM for 30 days. Per ANSI/UL 2034 requirements, the device will alarm at the following levels: 70 PPM CO between 1 to 4 hours, but not less than 1 hour. 150 PPM CO between 10 to 50 minutes. 400 PPM between 4 to 15 minutes.
- The GN-503 Series device shall have a Duracell® MN 1604 9VDC alkaline battery as a back-up in the event building power is lost.
- The 9VDC battery impedance shall be verified by the circuit of the smoke/CO alarm.
- The alarm shall provide an indicator when the battery is low in power, high impedance or is missing.
- The CO alarm will provide an audible indicator of 3 quick chirps every 30 seconds at end of life of CO sensor.
- The sensing chamber shall be fully protected to prevent entrance of small insects, thus reducing the probability of false alarms.
- The alarm shall include a solid state red color LED that will indicate presence of CO at the unit.
- The alarm shall include a solid state piezo alarm rated at 85dBA at 10ft.
- A visual LED monitor (condition indicator) shall slow pulse in normal operation and rapid pulse in alarm (red color)
- An easily accessible test button shall be provided. Push down on button for 5 seconds causing smoke/CO alarm to activate. If device does not go into alarm, the device is not working properly.
- The device shall have tandem interconnect capability of up to 12 smoke/CO alarms.
- The GN-503 and GN-503F alarm shall have the capability to tandem interconnect with all Gentex tandem capable smoke alarms, CO alarms or combination smoke/CO alarms, including 7000/7003 Series, 9000/9003 Series, 710CS/713CS Series, 7109CS/7139CS Series, GN-200/GN-300 Series, S1209 Series and CO1209 Series.
- The GN-503FF alarm shall have the capability to tandem interconnect with the following Gentex alarms, CO alarms or combination smoke/CO alarms: GN-503 Series, S1209 Series and CO1209 Series.
- The manufacturer shall provide models with the optional feature of auxiliary Form A/Form C relay contacts for initiating remote functions and annunciation and a relay option that is capable of activation by tandem interconnect wire.
- The combination smoke/CO alarm shall be non-latching (self-restoring).
- Unit must be ANSI/UL 217 and ANSI/UL 2034 listed for both wall and ceiling mounting.
- Unit shall be listed by Underwriters Laboratories and California State Fire Marshal (CSFM).

All equipment shall be completely factory assembled, wired and tested, and the contractor shall be prepared to submit a certified letter testifying to this condition. Alarms which do not meet all of the requirements of this specification will not be considered.

For complete product specifications, refer to product installation manual.

24 units per carton
24 pounds per carton



Fire Protection Products Group • www.gentex.com
10985 Chicago Drive • Zeeland, Michigan 49464
616.392.7195 • 1.800.436.8391 • 616.392.4219 Fax

Gentex Corporation reserves the right to make changes to the product data sheet at their discretion.

Important Notice:

These materials have been prepared by Gentex Corporation ("Gentex") for informational purposes only, are necessarily summary, and are not purported to serve as legal advice and should not be used as such. Gentex makes no representations and warranties, express or implied, that these materials are complete and accurate, up-to-date, or in compliance with all relevant local, state and federal laws, regulations and rules. The materials do not address all legal considerations as there is inevitable uncertainty regarding interpretation of laws, regulations and rules and the application of such laws, regulations and rules to particular fact patterns. Each person's activities can differently affect the obligations that exist under applicable laws, regulations or rules. Therefore, these materials should be used only for informational purposes and should not be used as a substitute for seeking professional legal advice. Gentex will not be responsible for any action or failure to act in reliance upon the information contained in this material.

551-0073-04