



3M™ Fire Barrier Duct Wrap 615+

Product Data Sheet and Installation Guide

(8-page Condensed Version)

1. Product Description

3M™ Fire Barrier Duct Wrap 615+ is a flexible fire-resistant wrap consisting of an inorganic fiber blanket encapsulated with a scrim-reinforced foil. The product is 1-1/2 in. thick, 6pcf density.¹ It is used to fire rate commercial kitchen grease ducts as well as ventilation ducts. 3M™ Fire Barrier Duct Wrap 615+ is a proven alternative to 1- or 2-hour fire-resistant rated shaft enclosures for grease ducts (ICC-ES ESR-1255). With its excellent insulating capabilities, low weight and thin profile, it is an ideal choice for a duct enclosure system. This non-asbestos² wrap installs easily due to its high flexibility and strength.

¹ In accordance with the tolerances in ASTM C 892 Standard Specification for High-Temperature Fiber Blanket Thermal Insulation.
² Has been demonstrated to be soluble in the lungs according to EU guideline 97/69/EG, for biopersistence.



Flexible and lightweight with a thin profile for easier application and reduced space requirements

Product Features

- Two-layer wrap for grease ducts rated as a shaft alternative per ASTM E 2336
- Zero clearance to combustible throughout the entire enclosure system for congested spaces
- Butted inner layer in 2-layer Grease Duct Applications
- One-layer wrap for fire-resistive ventilation ducts per ISO 6944
- High flexibility for installation ease
- Foil encapsulated for blanket protection, less dust, and high wrap strength
- Widest range of penetration seal systems
- Available in 24 in. x 25 ft. (609.6 mm x 7.62 m) and 48 in. x 25 ft. (1219.2 mm x 7.62 m) rolls
- Blanket adhered to foil scrim

2. Applications

3M™ Fire Barrier Duct Wrap 615+ is an ideal fire resistive enclosure for commercial kitchen grease ducts and ventilation air ducts. It is a proven performance alternative to a 1- or 2-hour fire-resistant rated shaft enclosures for grease ducts and provides zero clearance to combustible construction throughout the entire enclosure system. 3M™ Fire Barrier Water Tight Sealant 1000 NS, 3M™ Fire Barrier Water Tight Sealant 1003 SL or 3M™ Fire Barrier Silicone Sealant 2000+ is used in combination with 3M™ Fire Barrier Duct Wrap 615+ to firestop the duct when the duct penetrates fire-rated floor or wall assemblies. 3M™ Fire Barrier Duct Wrap 615+ also provides a firestop solution where a T-rating is required for penetrations located outside wall cavities or outside fire-resistance rated shaft enclosures.

Two-layer grease duct applications: 3M™ Fire Barrier Duct Wrap 615+ meets the criteria of ASTM E 2336 Standard Test Methods for Fire Resistive Grease Duct Enclosure Systems.

Single-layer air duct applications: 3M™ Fire Barrier Duct Wrap 615+ has passed ISO 6944-1985 Fire Resistance Tests – Ventilation Ducts.

T-rating for metallic through-penetrating items: 3M™ Fire Barrier Duct Wrap 615+ is used in conjunction with 3M Fire Barrier sealants to achieve up to 2-hour equal F & T-ratings in ASTM E 814 (UL 1479) tested through-penetrations.

3. Specifications

Installation shall be in strict accordance with manufacture's written instructions, as shown on the approved shop drawings. 3M™ Fire Barrier Duct Wrap 615+ shall be a high-temperature fiber blanket thermal insulation encapsulated in a fiberglass-reinforced aluminized polyester foil. Duct Wrap density shall be nominal 6 pcf (96 kg/m³) and have a nominal 1-1/2 in. (38.1 mm) thickness. The fiber blanket shall have a continuous use limit of 1000 °C (1832 °F). The blanket thermal resistance (R-value) at ambient temperature shall be minimum $6.3 \frac{^{\circ}F-ft^2-hr}{Btu}$.

Smoke Developed Index and Flame Spread Index of the bare blanket, and of the foil encapsulated blanket shall be 0/0. The foil encapsulation shall be bonded to the core blanket material.

For technical support relating to 3M Fire Protection Products and Systems, call: 1-800-328-1687

For more information on 3M Fire Protection Products, visit: www.3m.com/firestop

Typically Specified Division or Section

Division 7 – Thermal and Moisture Protection
 Section 23 07 13 – Duct Insulation

Related Sections

Section 07 21 00 – Thermal Protection
 Section 07 21 16 – Blanket Insulation
 Section 07 84 00 – Firestopping
 Section 23 00 00 – Heating, Ventilation and Air-Conditioning (HVAC)
 Section 23 31 13 – Metal Ducts

FIRE BARRIER

FLEXIBLE WRAP

ICC-ES ESR-1255

LISTED

Intertek

FIRE RESISTANT DUCT
SEE INTERTEK DIRECTORY

LISTED

Intertek

FIRE RESISTANT DUCT
SEE INTERTEK DIRECTORY

BATTS AND BLANKETS
FOR USE IN FIRE RESISTIVE DUCT ASSEMBLIES
SEE UL FIRE RESISTANCE DIRECTORY
9069

CSFM
LISTING No.
2440-0941:112



4. Performance & Typical Physical Properties

Scrim Color:	Aluminum with Black Text
Blanket Color:	White
Blanket Weight:	0.9 lbs./ft. ² (4.38 kg/m ²)
Surface Burning:	Foil Encapsulated Blanket (ASTM E 84) Flame Spread 0, Smoke Development 0

Thermal Conductivity:	Temp.	$\frac{Btu \cdot in.}{hr \cdot ft^2 \cdot ^\circ F}$	$\frac{W}{m^2 \cdot K}$
		500°F (260°C)	0.60
1000°F (537°C)	1.15	0.17	
1500°F (815°C)	1.93	0.28	
1800°F (982°C)	2.51	0.36	
2000°F (1093°C)	2.94	0.43	

Single layer R-Value of 3M™ Fire Barrier Duct Wrap 615+ at 77°F (25°C):

$$6.38 \frac{^\circ F \cdot ft^2 \cdot hr}{Btu}$$

Linear Shrinkage (24 Hr@ 2012°F (1000°C)): 1.2%

5. Design Listings

Grease Duct Listings – ASTM E 2336 / ICC-ES AC101

Fire Resistive Rating	Enclosure System	Third-Party Testing Services Design Listing	Description
1- and 2-hour	2 layers of 3M™ Fire Barrier Duct Wrap 615+	ICC-ES ESR-1255	Rectangular
		Intertek 3MU/FRD 120-18	Rectangular
		Intertek 3MU/FRD 120-19	Round

Ventilation Duct Listings – ISO 6944

Fire Resistive Rating	Enclosure System	Third-Party Testing Services Design Listing	Description
1- and 2-hour	1 layer of 3M™ Fire Barrier Duct Wrap 615+	Intertek 3MU/DI 60-01	Rectangular/Round (1 Hour)
		Underwriters Laboratories HNLJ.V-27	Rectangular (2 Hour)
		Intertek 3MU/DI 120-01	Rectangular/Round (2 Hour)

This document only contains a partial list of Design Listings. For the latest information go to www.3M.com/firestop or speak to your authorized 3M distributor or sales representative at (800) 328-1687.

6. Codes & Test Standards

3M™ Fire Barrier Duct Wrap 615+ has been tested in accordance with the following:

ASTM E 2336	Standard Test Methods for Fire Resistive Grease Duct Enclosure Systems
ICC-ES AC101	Acceptance Criteria for Grease Duct Enclosure Assemblies
ASTM E 119	Standard Test Methods for Fire Tests of Building Construction
ASTM E 814	Standard Test Method for Fire Tests of Penetration Firestop Systems
ASTM E 136	Standard Test Method for Behavior of Material in a Vertical Tube Furnace at 750°C (1382°F)
ASTM C 518	Standard Test Method for Steady-State Thermal Transmission Properties by Means of the Heat Flow Meter Apparatus
ASTM E 84	Standard Test Method for Surface Burning Characteristics of Building Materials
ISO 6944-85	Fire Resistance Tests – Ventilation Ducts

3M™ Fire Barrier Duct Wrap 615+, when installed per ASTM E 2336 tested Grease Duct Design Listings, meets the following code requirements:

NFPA 96	2008 Edition
International Mechanical Code®	2003/2006/2009
Uniform Mechanical Code	2003/2006/2009

3M™ Fire Barrier Duct Wrap 615+, when installed per ISO 6944 tested Ventilation Duct Design Listings, can help to satisfy the following code requirements:

NFPA 92A	Standard for Smoke-Control System Utilizing Barriers and Pressure Differences, 2009 Edition – Section 6.6.2
NFPA 92B	Standard for Smoke Management Systems in Malls, Atria, and Large Spaces, 2009 Edition – Section 7.5.2
International Mechanical Code®	2006/2009 Editions – Section 513.10.2
International Building Code®	2006/2009 Editions – Section 909.10.2

7. Packaging, Storage, Shelf Life

3M™ Fire Barrier Duct Wrap 615+ rolls are packaged in corrugated cardboard boxes. Product is stable under normal storage conditions. Normal stock and stock rotation practices are recommended. 3M™ Fire Barrier Duct Wrap 615+ shelf life is indefinite when stored in original unopened packaging in a dry warehouse environment. Pallets should not be stacked. 3M™ Fire Barrier Water Tight Sealant 1000 NS or 1003 SL or 3M™ Fire Barrier Silicone Sealant 2000+ must be also stored in a dry warehouse environment.

8. Installation Techniques

3M™ Fire Barrier Duct Wrap 615+ should be installed per the application design listing in accordance with the following basic installation instructions.

Material and Equipment

- 24 in. or 48 in. wide¹ by 1-1/2 in. (38.1 mm) thick² by 25 ft. (762 cm) standard length 3M™ Fire Barrier Duct Wrap 615+ blanket (60.96 cm or 121.92 cm by 38.1 mm by 762 cm)
- 3M™ FSK Facing Tape 3320 (aluminum foil, fiberglass scrim, kraft paper backing with acrylic adhesive or equivalent)
- Minimum 3/4 in. (19 mm) wide filament tape (Scotch® Filament Tape 898 recommended)
- Stainless steel or carbon steel banding material, minimum 1/2 in. (12.7 mm) wide and minimum 0.015 in. (0.38 mm) thick with banding clips of the same material
- Hand banding tensioner, crimping tool and banding cutter
- Minimum 12 gauge copper-coated steel insulation pins used with minimum 2-1/2 in. (63.5 mm) square galvanized steel or stainless speed clips or 1-1/2 in. (38.1 mm) dia. round or equivalent sized insulated cup-head pins
- Capacitor discharge stud gun
- Access door hardware: four galvanized steel thread rods, 1/4 in. diameter by minimum 6 in. long (6.35 mm by 152.4 mm) with 1/4 in. (6.35 mm) wing nuts and 1/4 in. (6.35 mm) washers
- 4 in. (102 mm) long steel hollow tubing to fit threaded rods
- Minimum 4 pcf (64 kg/m³) density mineral wool or scrap pieces of 3M™ Fire Barrier Duct Wrap 615+
- 3M™ Fire Barrier Water Tight Sealant (1000 NS or 1003 SL) or 3M™ Fire Barrier Silicone Sealant 2000+.

¹ Note: 48 in. (121.92 cm) wide blanket helps to maximize coverage since the 3 in. (76.2 mm) longitudinal overlaps occur less frequently.

² In accordance with the tolerances in ASTM C 892 Standard Specification for High-Temperature Fiber Blanket Thermal Insulation.

Preparatory Work

3M™ Fire Barrier Duct Wrap 615+ is installed with common insulation tools, such as knives, banders and capacitor discharge guns for applying insulation pins. In order to install the duct firestop system, the surfaces of all the openings and penetrating items need to be clean, dry, frost free and free of dust.

2-Layer Grease Duct Method (ASTM E 2336)

Note: This general instruction for applying 3M™ Fire Barrier Duct Wrap 615+ details a two-layer wrap installation of 3M™ Fire Barrier Duct Wrap 615+ blanket applied directly to a grease duct. To minimize waste, the 3M™ Fire Barrier Duct Wrap 615+ material should be rolled out tautly before measuring. The first layer of 3M™ Fire Barrier Duct Wrap 615+ blanket is wrapped around the perimeter of the duct and is cut to a length to either butt to itself or overlap itself not less than 3 in. (76.2 mm). The interface between adjacent blankets forms the "longitudinal" joint. Inner layer longitudinal joints can be tightly butted joints or they should overlap onto adjacent blankets with a min. 3 in. (76.2 mm) overlap. Aluminum foil tape is used to seal all cut edges of the blanket and any tears in the foil scrim. This first layer is temporarily held in place using filament tape. The first layer does not require steel banding.

The second layer of 3M™ Fire Barrier Duct Wrap 615+ blanket is wrapped around the perimeter of the previously installed first layer of 3M™ Fire Barrier Duct Wrap 615+. Regardless of installation method, offset the edge of the second layer a min. 10.5 in. (26.7 cm) for the perimeter overlap of the inner layer. In addition, the second layer perimeter (lateral) joint must be an overlap of not less than 3 in. (76.2 mm). When installing 3M™ Fire Barrier Duct Wrap 615+ onto grease ducts using any method except the Butt Joint with Collar method, the outer layer longitudinal joints must have a min. 3 in. (76.2 mm) overlap. With the Butt Joint with Collar method, the outer layer longitudinal joints are tightly butted and the 3M™ Fire Barrier Duct Wrap 615+ Collar is centered over the outer layer longitudinal joint. The second layer of blanket can be temporarily held in place using filament tape. The second layer of wrap requires permanent fastening with stainless (or carbon) steel banding, or with rows of weld pins (impaling or cup-head style).

3M™ Fire Barrier Duct Wrap 615+ Commercial Kitchen Grease Duct Systems (Figure 1)

1- or 2-Hour Shaft Alternative Zero Clearance to Combustibles Telescoping Wrap Technique With Banding For Ducts 24 inches (60.9 cm) or Less

1. First layer 3M™ Fire Barrier Duct Wrap 615+
2. Second layer 3M™ Fire Barrier Duct Wrap 615+
3. 3/4 in. (19 mm) wide filament tape
4. Steel banding 1/2 in. (12.7 mm) wide min. typical for permanent fastening
5. Longitudinal joint butt or min. 3 in. (76.2 mm) overlap on inner layer, min. 3 in. (76.2 mm) overlap on outer layer
6. Perimeter (lateral) joint butt or min. 3 in. overlap (76.2 mm) on inner layer, min. 3 in. (76.2 mm) overlap on outer layer
7. Metallic commercial cooking exhaust duct

System integrity is limited by quality of installation.

Ducts \geq 24 in. (60.9 cm) wide require pinning on the bottom side of horizontal ducts and on a minimum of one of the wider sides of a vertical duct. Vertical ducts require pinning on any side $>$ 48 in. (121.8 cm).

Consult current independent testing laboratories (e.g. Intertek, UL) for design or system details.

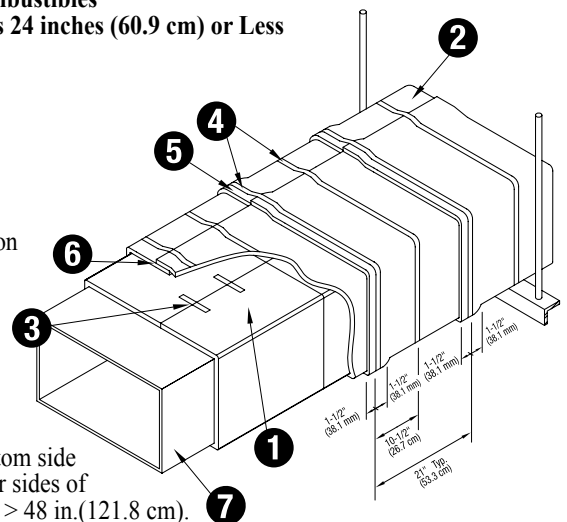

8. Installation Techniques cont.

3M™ Fire Barrier Duct Wrap 615+ Ventilation Duct Systems (Figure 2)

1. 3M Fire Barrier Duct Wrap 615+, 1-layer
2. Perimeter (lateral) joint min. 3 in. (76.2 mm) overlap
3. 3/4 in. (19 mm) wide filament tape
4. Steel banding 1/2 in. (12.7 mm) wide min. typical for permanent fastening
5. Longitudinal joint min. 3 in. (76.2 mm) overlap
6. Metallic HVAC duct

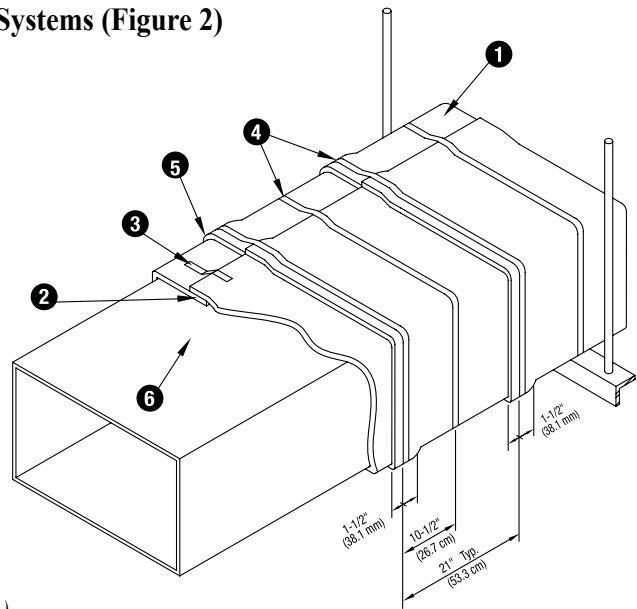

System integrity is limited by quality of installation.

Ducts ≥ 24 in. (60.9 cm) wide require pinning on the bottom side of horizontal ducts and on a minimum of one of the wider sides of a vertical duct. Vertical ducts require pinning on all sides that are > 48 in. (121.8 cm).

Consult current independent testing laboratories (e.g. Intertek, UL) for design or system details.

Duct Support

Horizontal duct assemblies with maximum cross-sectional openings of 24 in. x 24 in. (610 mm x 610 mm) must be supported with min. 3/8 in. diameter (9.5 mm), all-thread steel rod and 2 in. x 2 in. x 1/8 in. (51 mm x 51 mm x 3.2 mm) steel angle, spaced a maximum of 60 in. (1524 mm) on center. A min. clearance of 0 in. and a max. clearance of 6 in. (152 mm) is required between the vertical edge of the blanket material surrounding the duct and the steel rod. Horizontal duct assemblies with max. dimensions of 24 in. x 48 in. (610 mm x 1219 mm) must be supported with min. 1/2 in. diameter (12.7 mm), all-thread steel rod and 2 in. x 2 in. x 1/4 in. (51 mm x 51 mm x 6.4 mm) steel angle spaced a max. of 60 in. (1524 mm) on center. A min. clearance of 0 in. (0 mm) and a max. clearance of 6 in. (152 mm) is required between the vertical edge of the blanket material surrounding the duct and the steel rod. Vertical ducts must be supported at every floor line on the top of the slab.

Pinning & Banding Options

Duct Width	Banding Only	Banding with Bottom-Side Pinning	Pinning Only (All 4 sides)
width ≤ 24 "	✓		✓
24" $>$ width ≤ 48 "		✓	✓
width > 48 "			✓

8. Installation Techniques cont.

Four (4) approved grease duct installation techniques: 3M™ Fire Barrier Duct Wrap 615+

1A. Butt Joint Inner Layer with Telescoping Outer Layer

With the Butt-Joint Inner Layer and Telescoping Outer Layer technique, the inner layer of blankets abut the adjacent pieces of blanket. The outer layer blankets each overlap one adjacent blanket, and then the exposed edge is covered by the next blanket as shown in Figure 1A.

- 1A. First layer of 3M™ Fire Barrier Duct Wrap 615+
- 1B. Second layer of 3M™ Fire Barrier Duct Wrap 615+
2. Steel banding 1/2 in. (12.7 mm) wide min. typical
3. 3 in. (76.2 mm) min. longitudinal overlap
4. Tightly butted joint

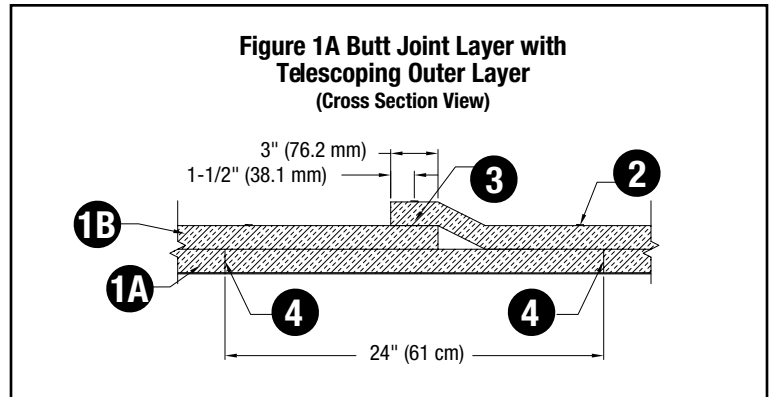

1B. Telescoping 3 in. (76.2 mm) Overlap Wrap

With the Telescoping Overlap Wrap method, each blanket overlaps one adjacent blanket, and each blanket has one edge exposed and one edge covered by the next blanket as shown in Figure 1B.

- 1A. First layer of 3M™ Fire Barrier Duct Wrap 615+
- 1B. Second layer of 3M™ Fire Barrier Duct Wrap 615+
2. Steel banding 1/2 in. (12.7 mm) wide min. typical
3. 3 in. (76.2 mm) min. longitudinal overlap

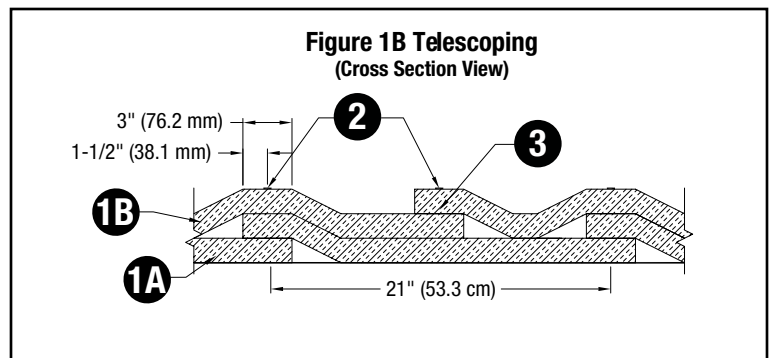

1C. Checkerboard 3 in. (76.2 mm) Overlap Wrap

With the 3 in. (76.2 mm) Checkerboard Overlap Wrap method, blankets with both edges exposed alternate with blankets with covered edges, as shown in Figure 1C.

- 1A. First layer of 3M™ Fire Barrier Duct Wrap 615+
- 1B. Second layer of 3M™ Fire Barrier Duct Wrap 615+
2. Steel banding 1/2 in. (12.7 mm) wide min. typical
3. 3 in. (76.2 mm) min. longitudinal overlap

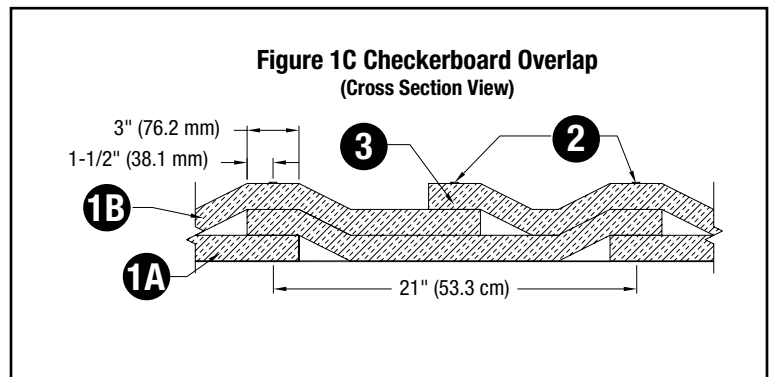

1D. Butt Joint with Collar

With the Butt Joint and Collar method, adjacent blankets are butted tightly together and 6 in. (152.4 mm) wide collar of duct wrap is centered over the joint, overlapping each blanket by 3 in. (76.2 mm) minimum as shown in Figure 1D.

- 1A. First layer of 3M™ Fire Barrier Duct Wrap 615+
- 1B. Second layer of 3M™ Fire Barrier Duct Wrap 615+
2. Steel banding 1/2 in. (12.7 mm) wide min. typical
3. 6 in. (152.4 mm) min. wide 3M™ Fire Barrier Duct Wrap 615+ Collar
4. Tightly butted joint

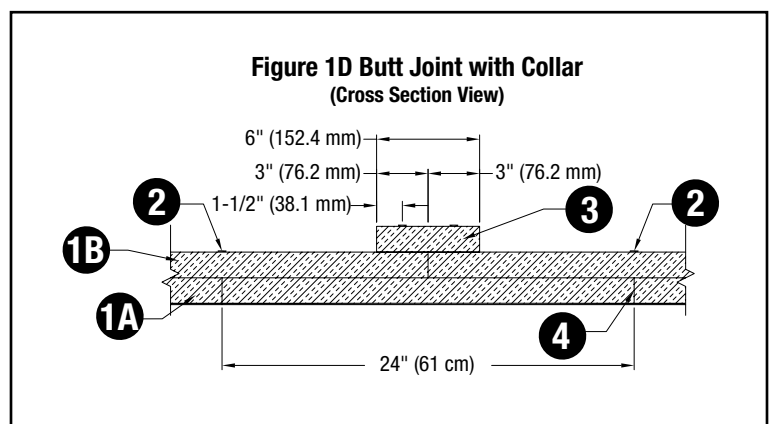

8. Installation Techniques cont.

Access Door Installation

Four galvanized steel threaded rods, 1/4 in. diameter (6.35 mm) by 4-1/2 in. to 5 in. long (114.3 mm to 127 mm) are welded to the duct at the corners of the door opening. Four steel tubes, each 3 in. (76.2 mm) long, are placed over the rods to act as protection for the 3M™ Fire Barrier Duct Wrap 615+, and to transfer the wing nut force to the access door, when fastening the door. Four insulation pins are welded to the door panel for installation of the blanket. One layer of 3M™ Fire Barrier Duct Wrap 615+ is cut approximately the same size as the access panel and impaled over the insulation pins on the panel. It is essential that this layer fit tightly against the wrap surrounding the access door opening with no through openings. A second layer of 3M™ Fire Barrier Duct Wrap 615+ is cut to overlap the first layer by a minimum of 1 in. (25.4 mm). Impale the second layer over the pins. A third layer of 3M™ Fire Barrier Duct Wrap 615+ is cut to overlap the second layer by a minimum of 1 in. (25.4 mm). The third layer is impaled over the pins and all three layers are locked in place with galvanized or stainless steel speed clips. Pins that extend beyond the outer layer of 3M™ Fire Barrier Duct Wrap 615+ should be turned down or cut off to avoid sharp points on the door. The insulated door panel is placed over the threaded rods and held in place with washers and wing nuts. The details are shown in Figure 3. The details for installing the 3M™ Fire Barrier Grease Duct Access Door (pre-manufactured) are shown in Figure 3A.

3M™ Fire Barrier Duct Wrap 615+ Commercial Kitchen Grease Duct Systems (Figure 3)

Field-Fabricated 1- or 2-Hour Access Door System

1. Access hole
2. 1/4 in. (6.35 mm) dia. all-threaded rods
3. Access door cover – 16 gauge
4. Insulation pins (impaling pins) – welded (optional)
5. First layer 3M™ Fire Barrier Duct Wrap 615+ cut same size as cover
6. Second layer 3M™ Fire Barrier Duct Wrap 615+ with 1 in. (25.4 mm) overlap on all sides
7. Third layer 3M™ Fire Barrier Duct Wrap 615+ with 1 in. (25.4 mm) overlap on all sides
8. Speed clips (optional)
9. Aluminum tape covering all exposed edges
10. Spool pieces for threaded rods
11. 1/4 in. (6.35 mm) diameter wings nuts

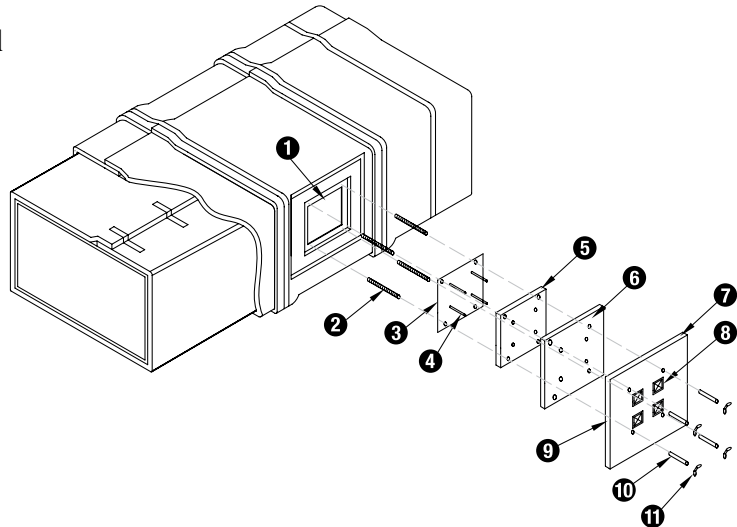

Note: System integrity is limited by quality of installation. Consult current independent testing laboratories (e.g. Intertek, UL) for Design or System Details. In all four overlap techniques the perimeter overlap can occur at any location on the duct.

3M™ Fire Barrier Duct Wrap 615+ Commercial Kitchen Grease Duct Systems (Figure 3A)

Pre-Fabricated 1- or 2-Hour Access Door System

1. Access hole
2. 1/4 in. (6.35 mm) dia. all-threaded rods
3. 3M™ Fire Barrier Grease Duct Access Door
4. Insulation pins (impaling pins) – welded
5. First layer 3M™ Fire Barrier Duct Wrap 615+ with 1 in. (25.4 mm) overlap beyond access door on all sides
6. Second layer 3M™ Fire Barrier Duct Wrap 615+ cut to same size as first layer
7. Third Layer 3M™ Fire Barrier Duct Wrap 615+ with 1 in. (25.4 mm) overlap beyond second layer on all sides
8. Speed clips
9. Aluminum tape covering all exposed edges
10. 1/4 in. (6.35 mm) diameter wings nuts
11. Insulation pins (cup-head pins) – welded
12. Access door cover – 16 gauge cut same size as third layer of duct wrap with clearance holes to match pattern of all-threaded rods

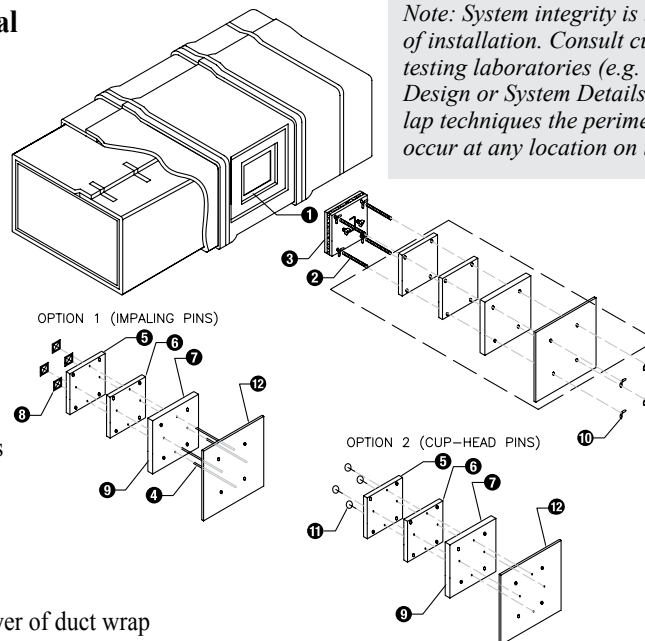

Note: System integrity is limited by quality of installation. Consult current independent testing laboratories (e.g. Intertek, UL) for Design or System Details. In all four overlap techniques the perimeter overlap can occur at any location on the duct.

8. Installation Techniques cont.

Penetrations

When the duct penetrates a fire rated wall, ceiling or floor, an approved firestop system must be employed. Figures 4-6 illustrate typical conditions. To firestop the wrapped duct, follow the installation parameters detailed in a compatible ASTM E 814 tested through-penetration firestop design. Note: Through-penetration designs in which the duct is bare where it passes through combustible or limited-combustible construction (e.g. gypsum walls or wood joist floor-ceiling assemblies) are appropriate for ventilation duct scenarios only. It is not appropriate for bare, uninsulated grease ducts to pass through combustible assemblies. Intertek 3MU/DI design listings contain through penetration details. See system details of UL System HNLJ.V-27, Section 3.C. for applicable UL through penetration systems.

3M™ Fire Duct Wrap 615+ Typical Through Penetration Firestop System (Figure 4)

1-Hour Through Penetration Systems Fire-Rated Wood/Gypsum Floor/Ceiling Assembly

1. Floor/ceiling assembly
 2. Duct
 3. One or two layers 3M™ Fire Barrier Duct Wrap 615+
 4. Banding or pinning
 5. 3M™ Fire Barrier Packing Material PM 4, 4 pcf mineral wool or scrap duct wrap (min. 33% compressed)
 6. 3M™ Fire Barrier Water Tight Sealant 1000 NS, 3M™ Fire Barrier Water Tight Sealant 1003 SL, or 3M™ Fire Barrier Silicone Sealant 2000+
- Note: Sealant to be applied at a minimum 5/8 in. (15.9 mm) depth

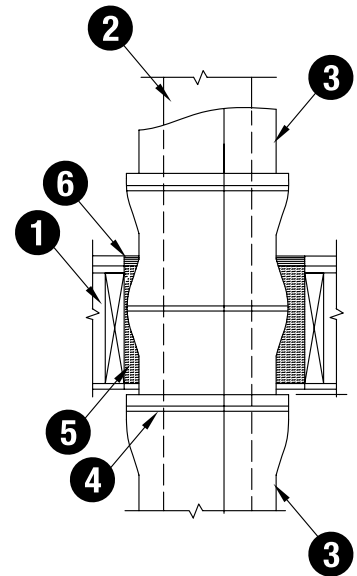

Note: System integrity is limited by quality of installation. Consult current independent testing laboratories (e.g. Intertek, UL) for Design or System Details.

3M™ Fire Duct Wrap 615+ Typical Through Penetration Firestop System (Figure 5)

1- or 2-Hour Through Penetration Systems – Gypsum Wallboard

1. Gypsum wallboard assembly
 2. Duct
 3. One or two layers 3M™ Fire Barrier Duct Wrap 615+
 4. Banding or pinning
 5. 3M™ Fire Barrier Packing Material PM 4, 4 pcf mineral wool or scrap duct wrap (min. 33% compressed)
 6. 3M™ Fire Barrier Water Tight Sealant 1000 NS or 3M™ Fire Barrier Silicone Sealant 2000+
- Note: Sealant to be applied at a minimum 5/8 in. (15.9 mm) depth

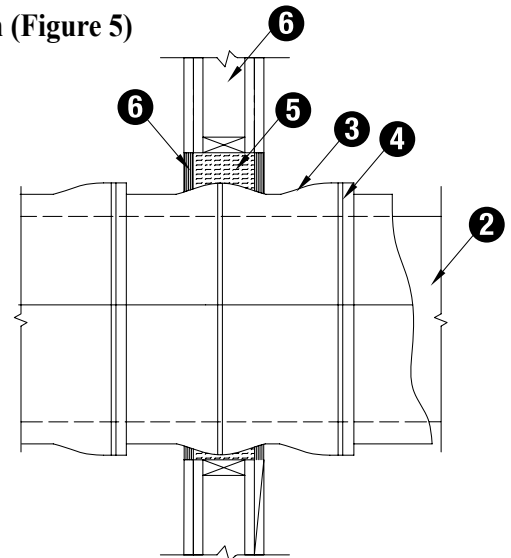

Note: System integrity is limited by quality of installation. Consult current independent testing laboratories (e.g. Intertek, UL) for Design or System Details.

3M™ Fire Duct Wrap 615+ Typical Through Penetration Firestop System (Figure 6)

1- or 2-Hour Through Penetration Systems
4-1/2 inch (11.4 cm) Concrete Floor or Wall

1. Floor/ceiling or wall assembly
 2. Duct
 3. One or two layers 3M™ Fire Barrier Duct Wrap 615+
 4. Banding or pinning
 5. 3M™ Fire Barrier Packing Material PM 4, 4 pcf mineral wool or scrap duct wrap (min. 33% compressed)
 6. 3M™ Fire Barrier Water Tight Sealant 1000 NS, 3M™ Fire Barrier Water Tight Sealant 1003 SL, or 3M™ Fire Barrier Silicone Sealant 2000+
- Note: Sealant to be applied at a minimum 5/8 in. (15.9 mm) depth

For wall assembly apply sealant to both sides of wall (note: 3M™ Fire Barrier Water Tight Sealant 1003 SL Not Suited For Wall Applications).

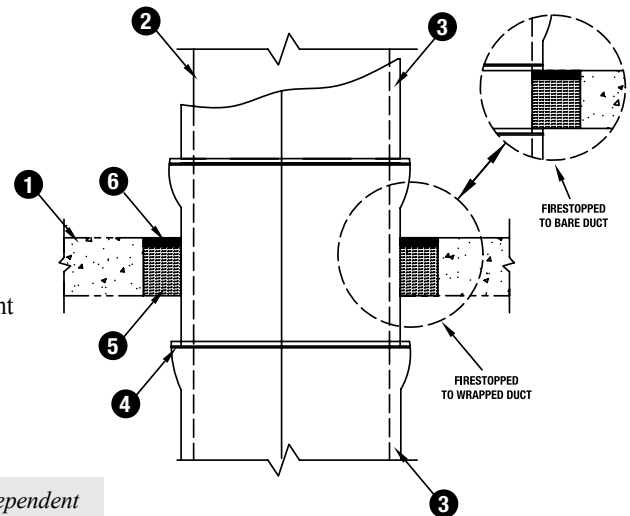

Note: System integrity is limited by quality of installation. Consult current independent testing laboratories (e.g. Intertek, UL) for Design or System Details.

For technical data and properties of 3M™ Fire Barrier Water Tight Sealant 1000 NS, 3M™ Fire Barrier Water Tight Sealant 1003 SL or 3M™ Fire Barrier Silicone Sealant 2000+, see separate product data sheets available from your 3M representative or go to www.3M.com/firestop.

9. Maintenance

No maintenance is expected when installed in accordance with the applicable Intertek, UL or other third-party listed system and in accordance with 3M™ Fire Barrier Duct Wrap 615+ Installation Guidelines. Once installed, if any section of the 3M™ Fire Barrier Duct Wrap 615+ is damaged such that the blanket requires repair, the following procedure will apply:

1. If the blanket has not been damaged but the foil has ripped, seal the rips with aluminum foil tape.
2. If the blanket has been damaged:
 - a. The damaged section should be removed by cutting the steel banding or removing the clips holding it in place.
 - b. A new section of the same dimension should be cut from a roll of 3M™ Fire Barrier Duct Wrap 615+, either 24 in. (60.9 cm) or 48 in. (121 cm) wide.
 - c. The new section should be placed and fitted ensuring the same overlap that existed previously (i.e. the original installation method).
 - d. The steel banding should be placed around the material and tensioned so as to sufficiently hold the 3M™ Fire Barrier Duct Wrap 615+ in place.

10. Availability

3M™ Fire Barrier Duct Wrap 615+ is available from 3M Authorized Fire Protection Products Distributors and Dealers. 3M™ Fire Barrier Duct Wrap 615+ is available in 24 in x 25 ft, Roll (1/case), 48 in x 25 ft, Roll (1/case). 3M™ Fire Barrier Duct Wrap Collars 615+ are available in 1.5 in x 6 in x 25 ft, Rolls (4/case). For additional technical and purchasing information regarding this and other 3M Fire Protection Products, please call: 1-800-328-1687 or visit www.3m.com/firestop.

11. Safe Handling Information

Prior to handling or disposal of 3M Fire Protection Products, consult all relevant Material Safety Data Sheets (MSDS).

Important Notice to User:

Technical Information: The technical information, recommendations and other statements contained in this document are based upon tests or experience that 3M believes are reliable, but the accuracy or completeness of such information is not guaranteed.

Product Use: Many factors beyond 3M's control and uniquely within user's knowledge and control can affect the use and performance of a 3M product in a particular application. Given the variety of factors that can affect the use and performance of a 3M product, user is solely responsible for evaluating the 3M product and determining whether it is fit for a particular purpose and suitable for user's method of application.

Warranty and Limited Remedy: 3M warrants that each 3M Fire Protection Product will be free from defects in material and manufacture for 90 days from the date of purchase from 3M's authorized distributor. 3M MAKES NO OTHER EXPRESS OR IMPLIED WARRANTIES, INCLUDING ANY IMPLIED WARRANTY OF MERCHANTABILITY OR FITNESS FOR A PARTICULAR PURPOSE. If a 3M product does not conform to this warranty, the sole and exclusive remedy is, at 3M's option, replacement of the 3M product or refund of the purchase price.

Limitation of Liability: Except where prohibited by law, 3M will not be liable for any loss or damage arising from the 3M product, whether direct, indirect, special, incidental or consequential, regardless of the legal theory asserted.

3M

Building and Commercial Services Division

3M Center, Building 223-2N-21
St. Paul, MN 55144-1000 USA
1-800-328-1687
www.3M.com/firestop