

COPYRIGHT: Reuse or reproduction of the contents of this document is not permitted without written permission of Bild Architecture LLC



Bild Architecture
PO Box 8235
Portland, ME
04104
207.408.0168
evan@bildarchitecture.com

10/25/16
EVAN
CARROLL
No. 3687
STATE OF MAINE

PROJECT NO. **15031**
PROJECT NAME **SALVATION ARMY ARC
PORTLAND, ME**

REVISIONS
11 11/8/16
2 1/18/16
3
4
5

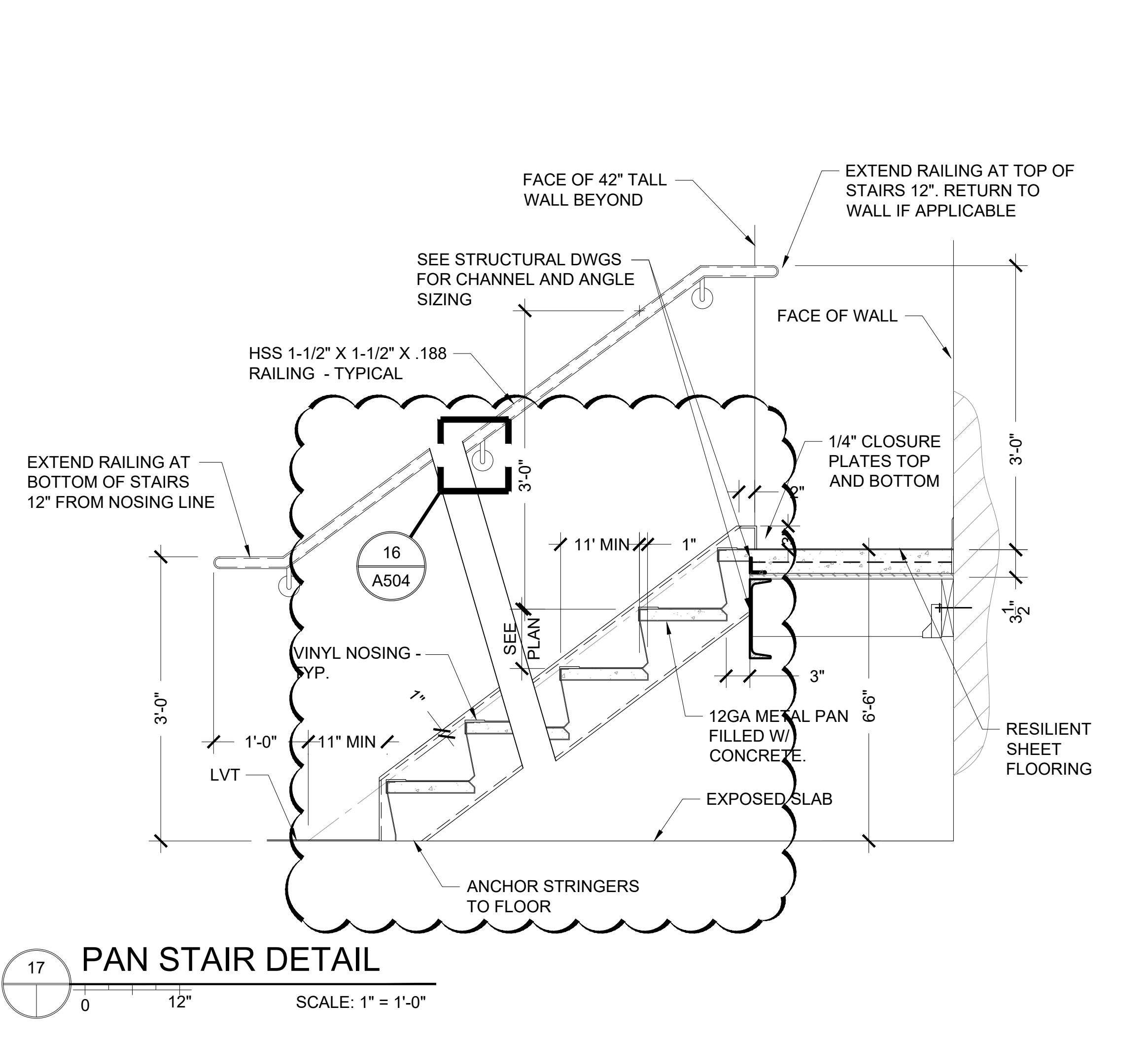
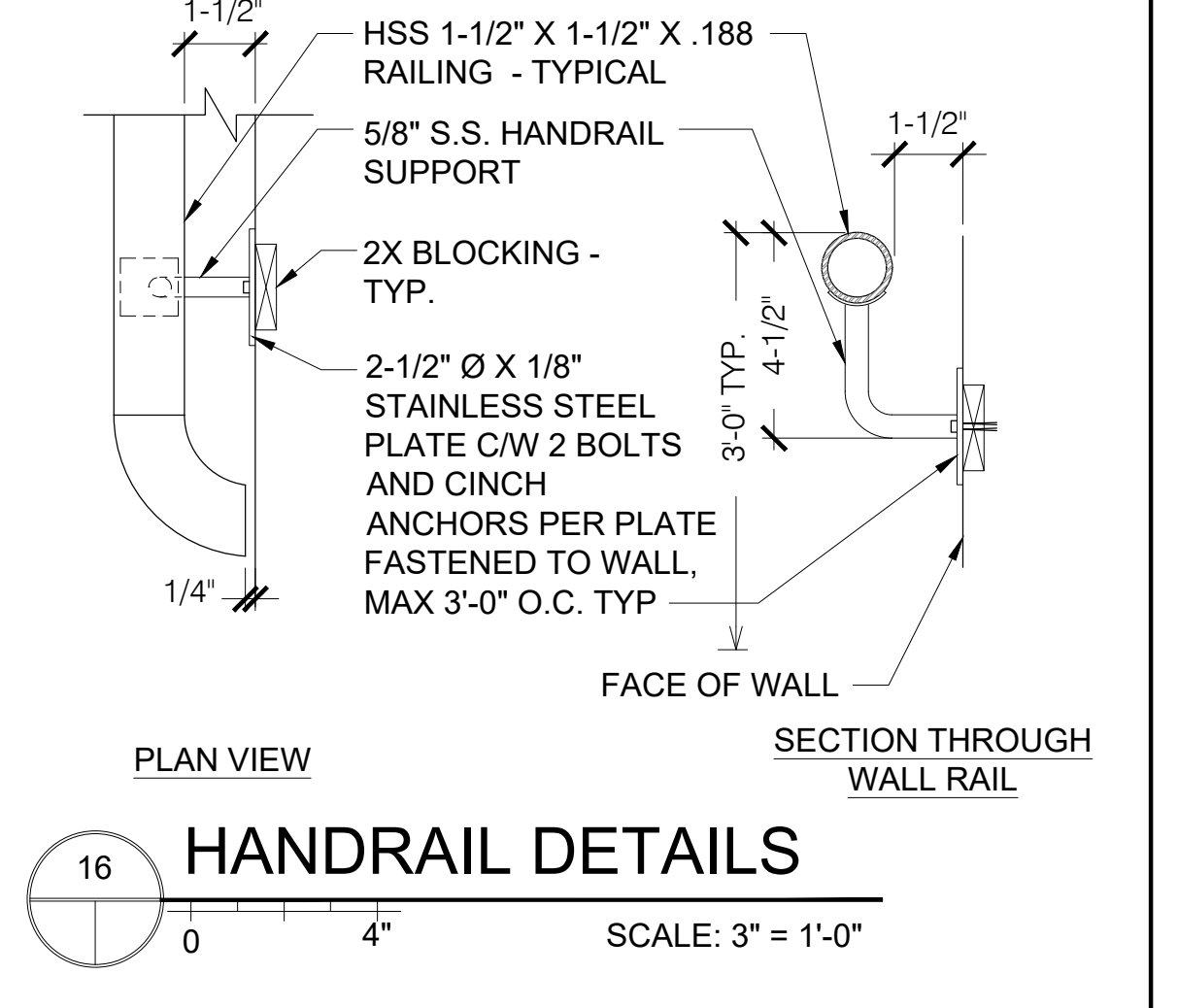
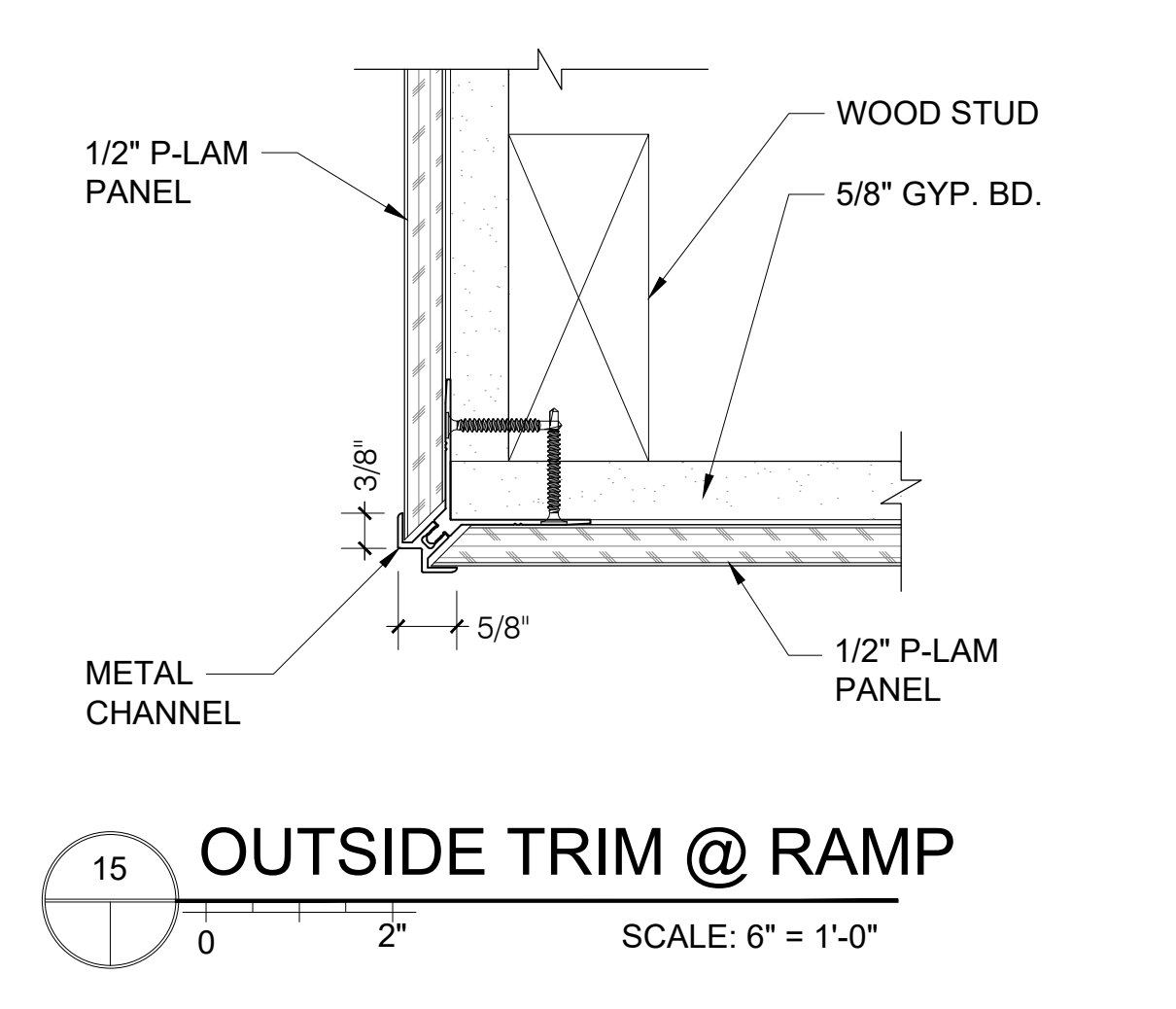
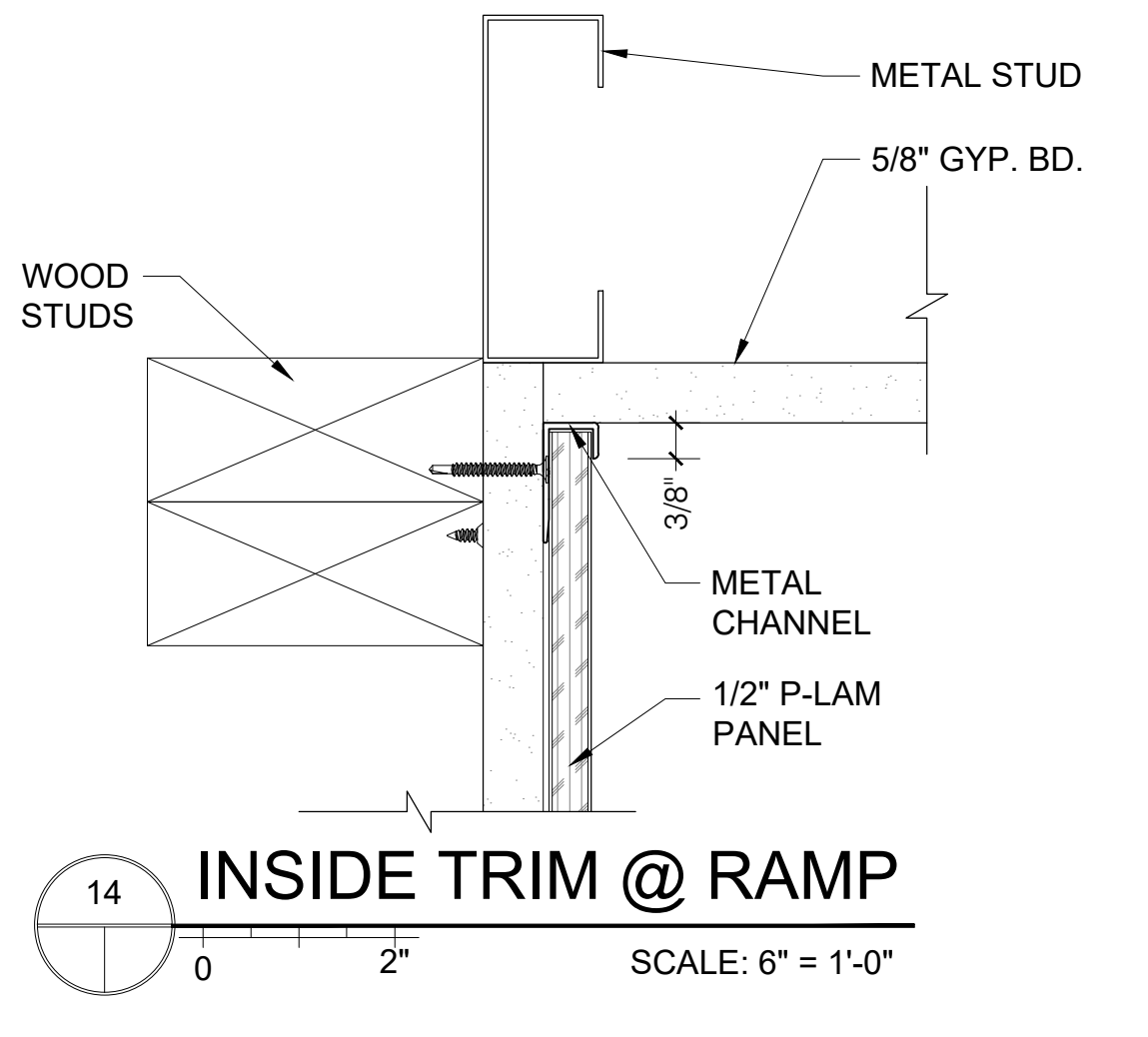
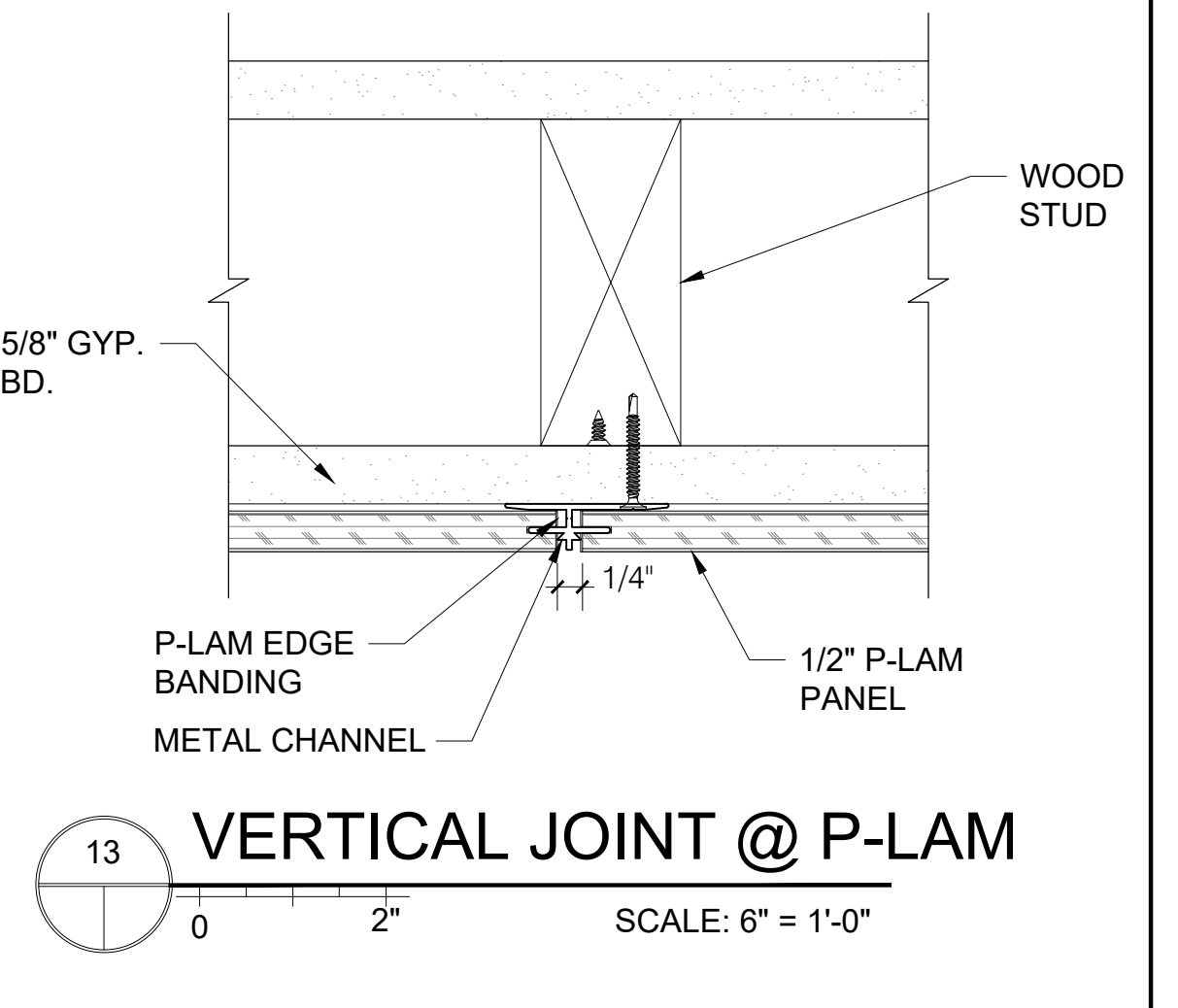
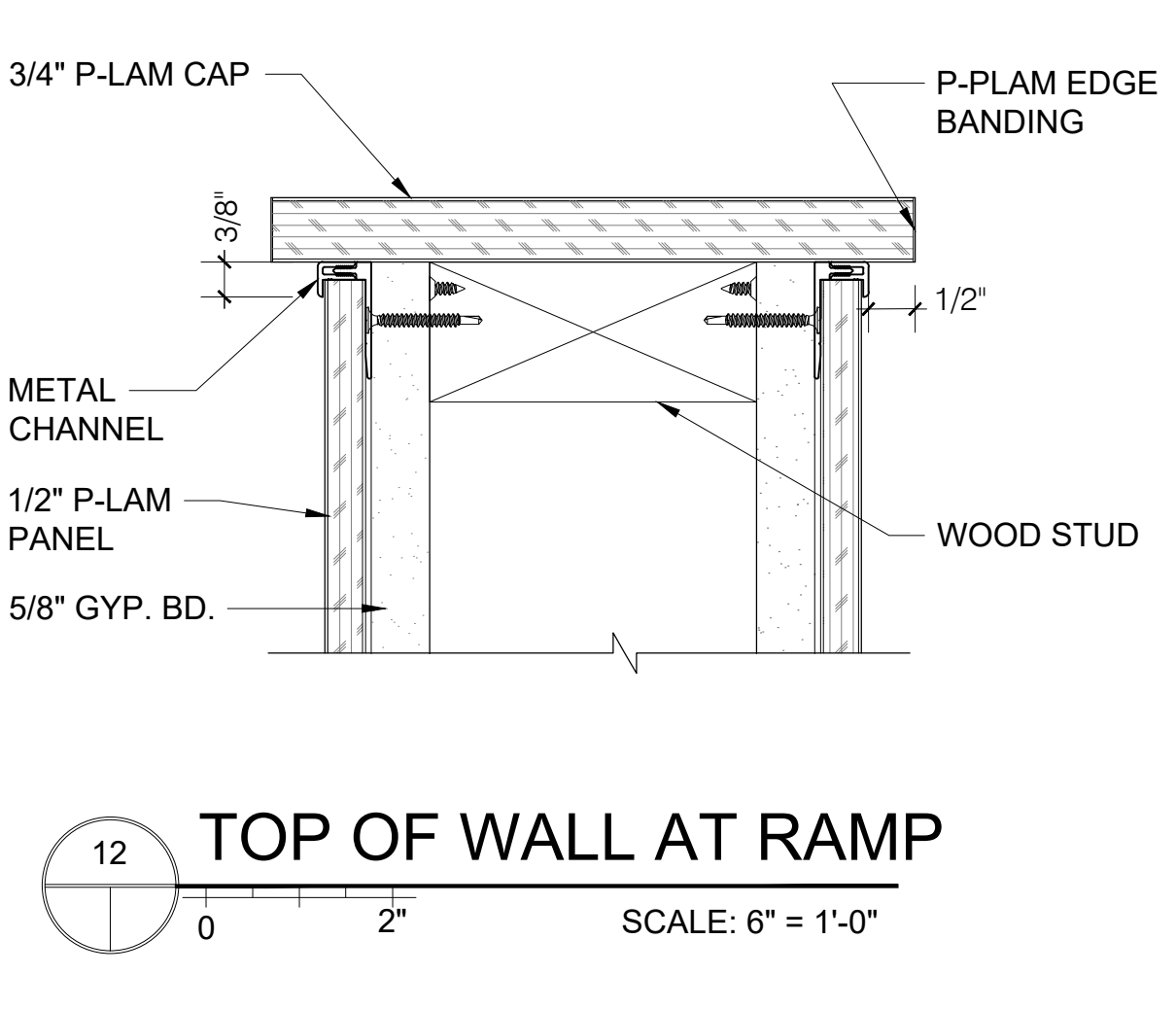
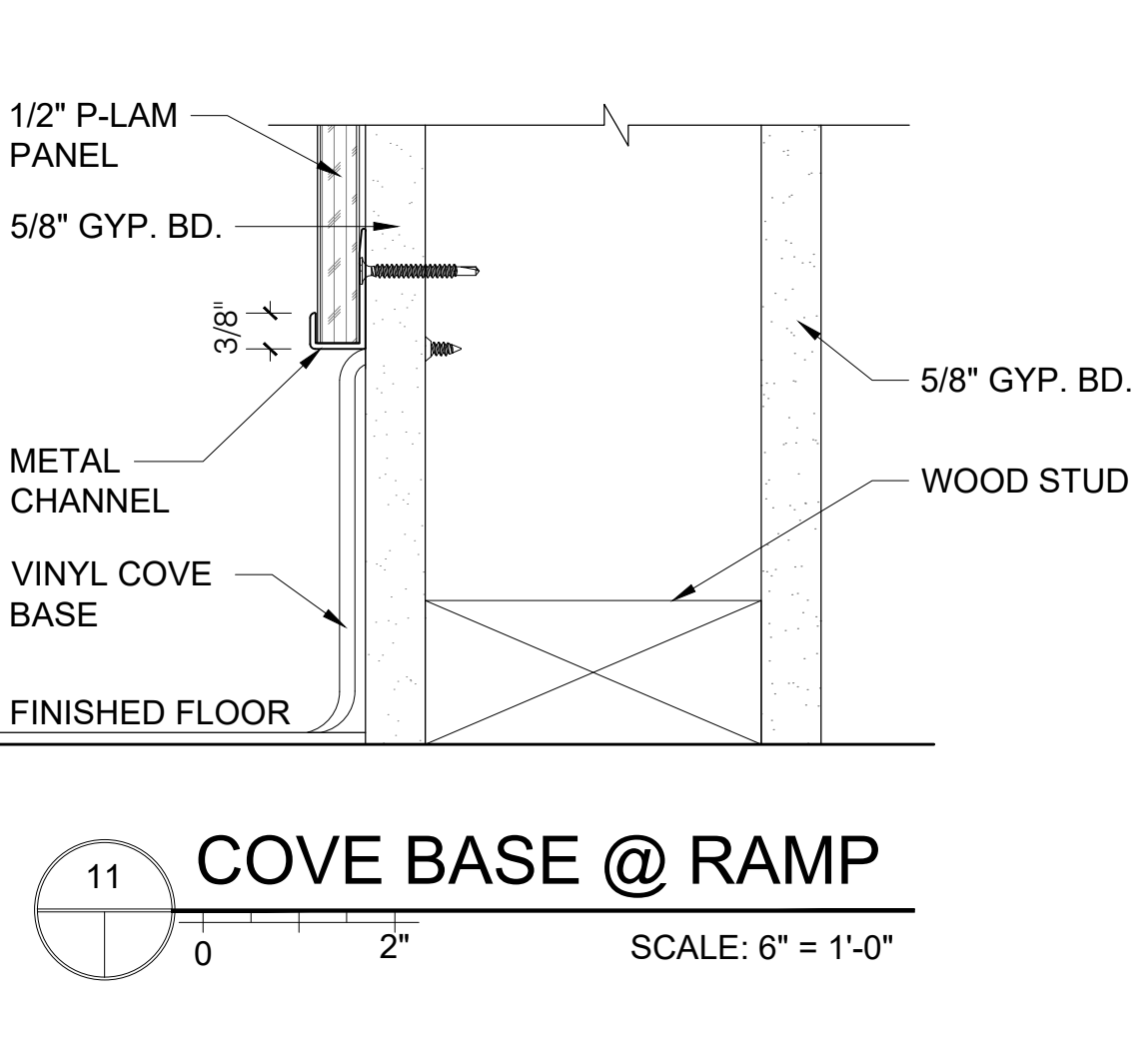
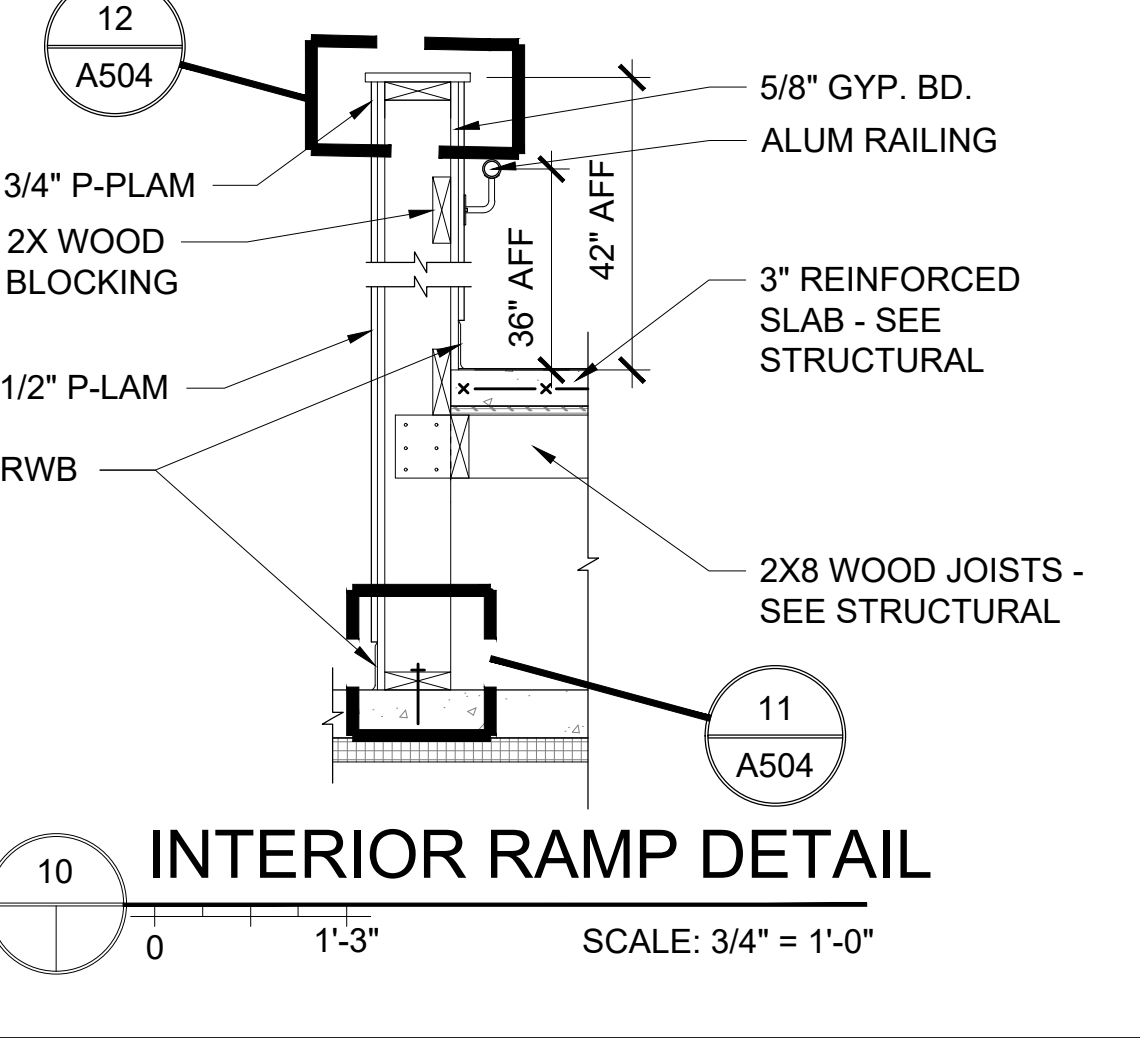
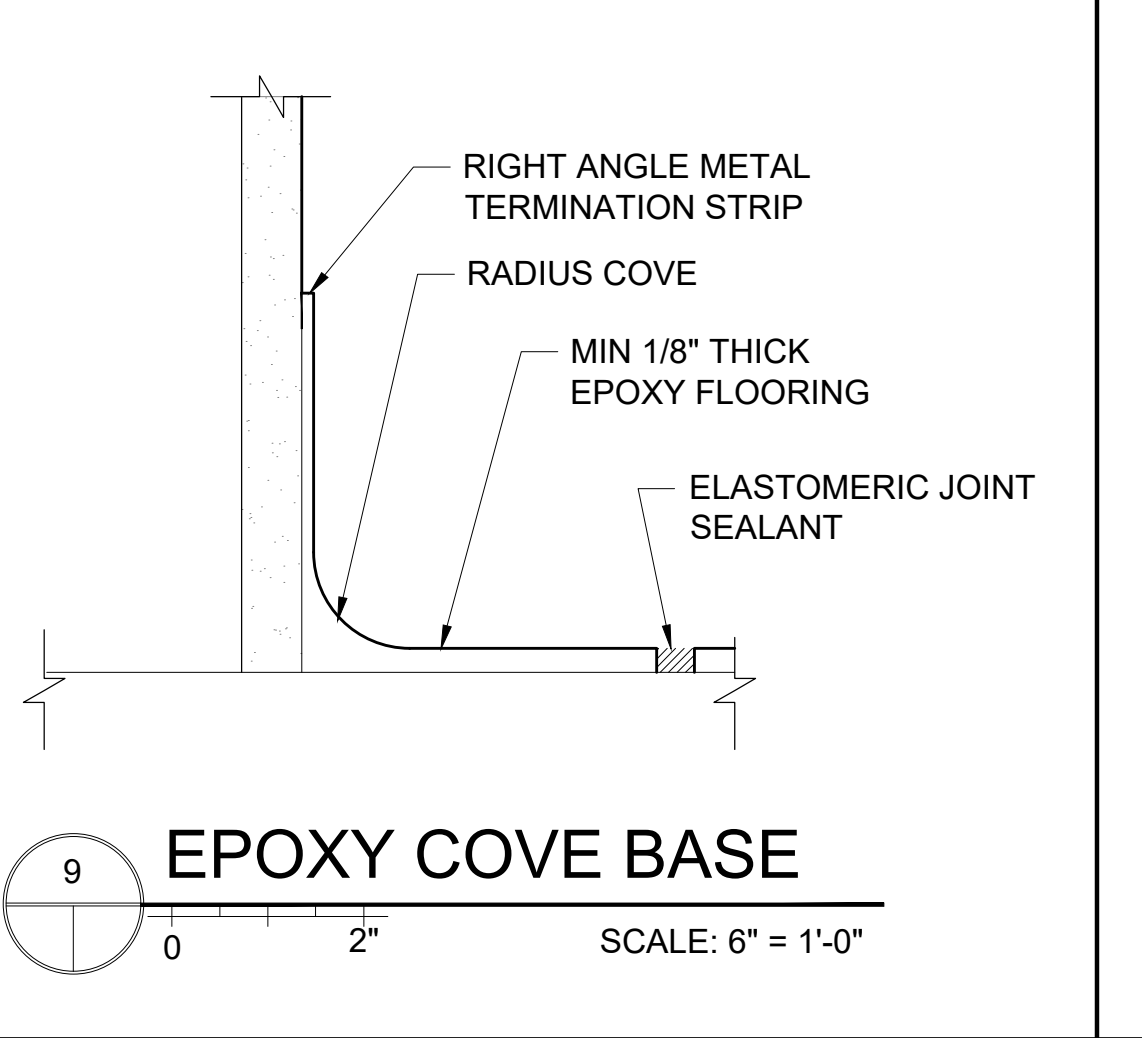
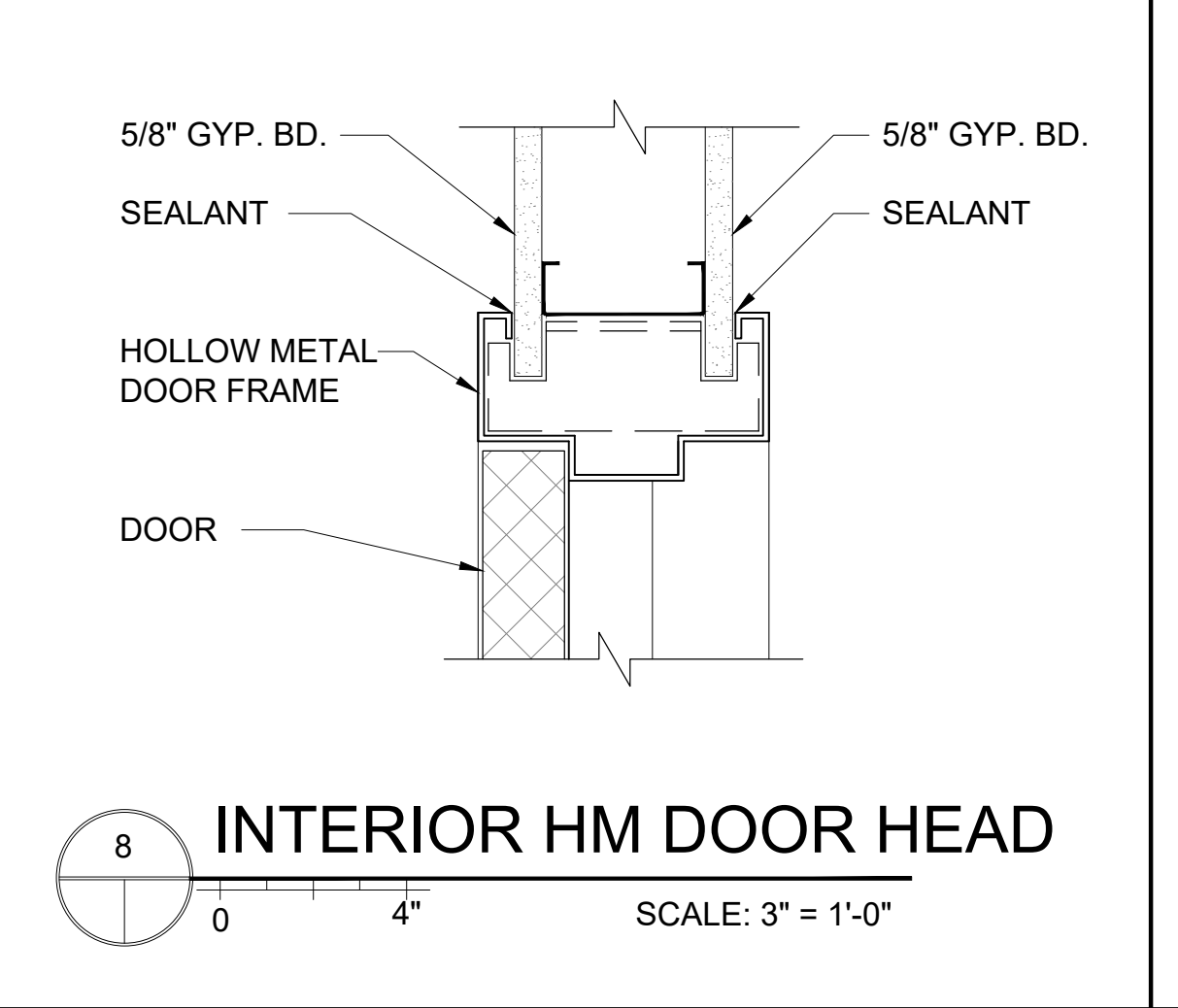
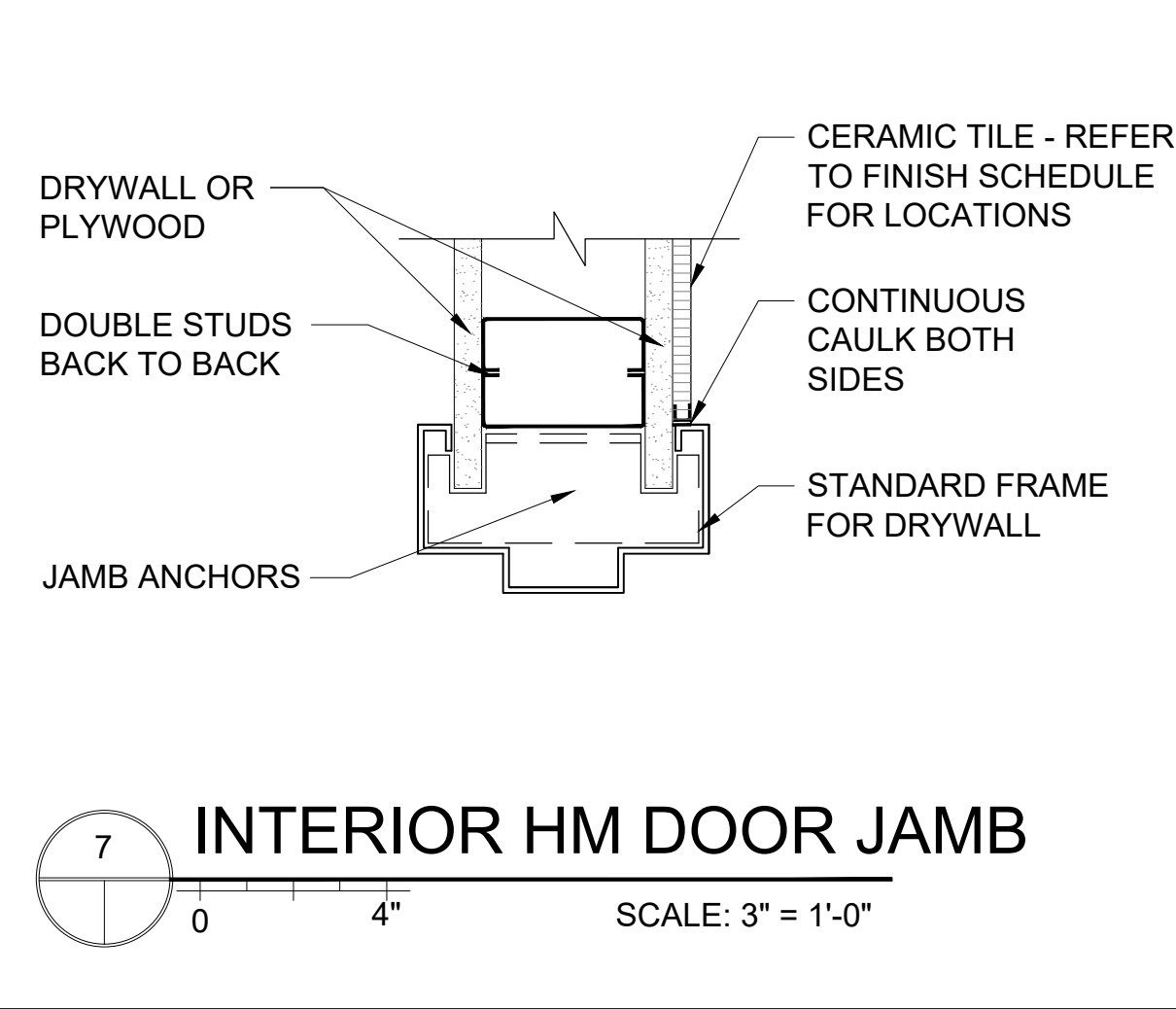
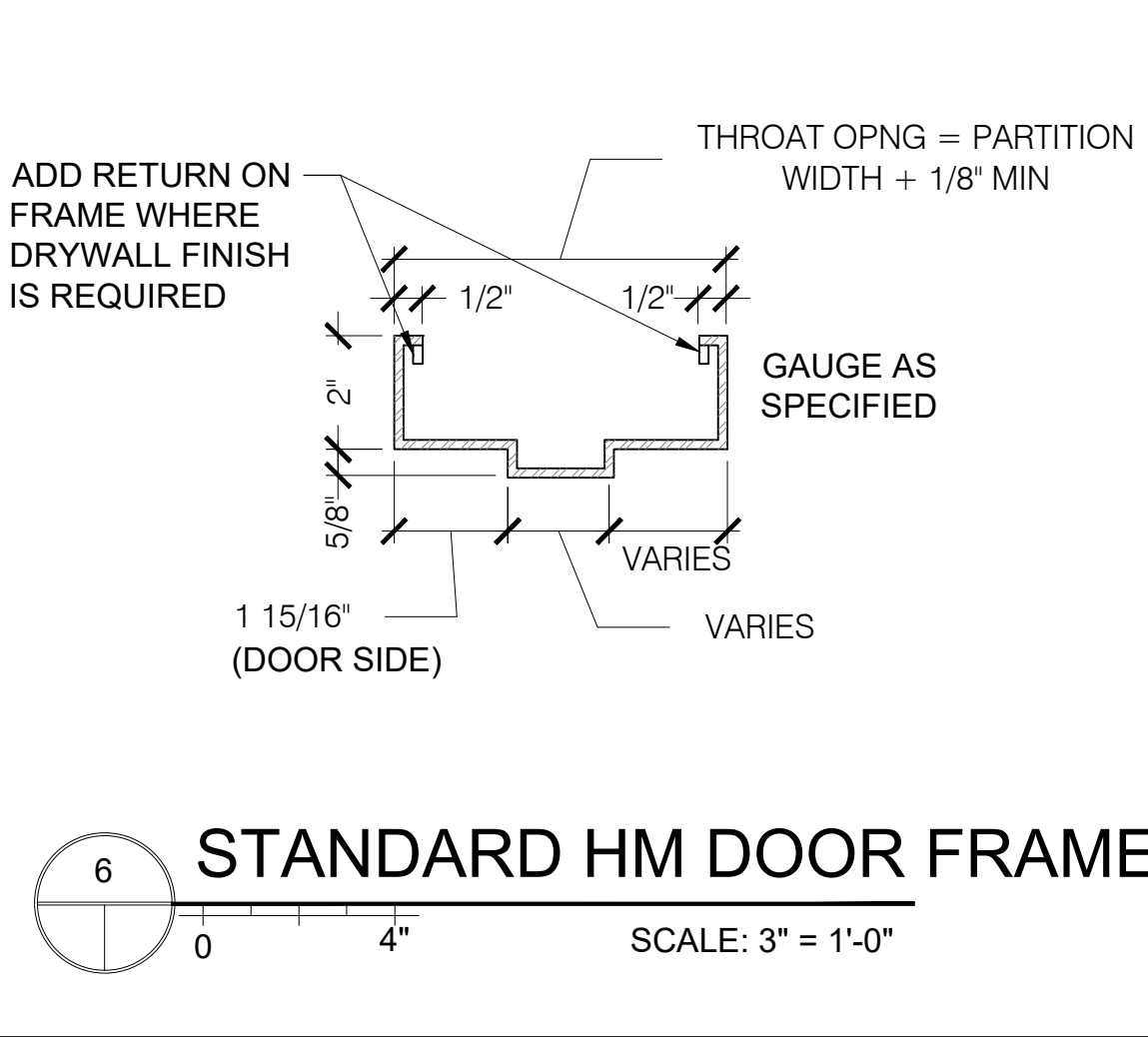
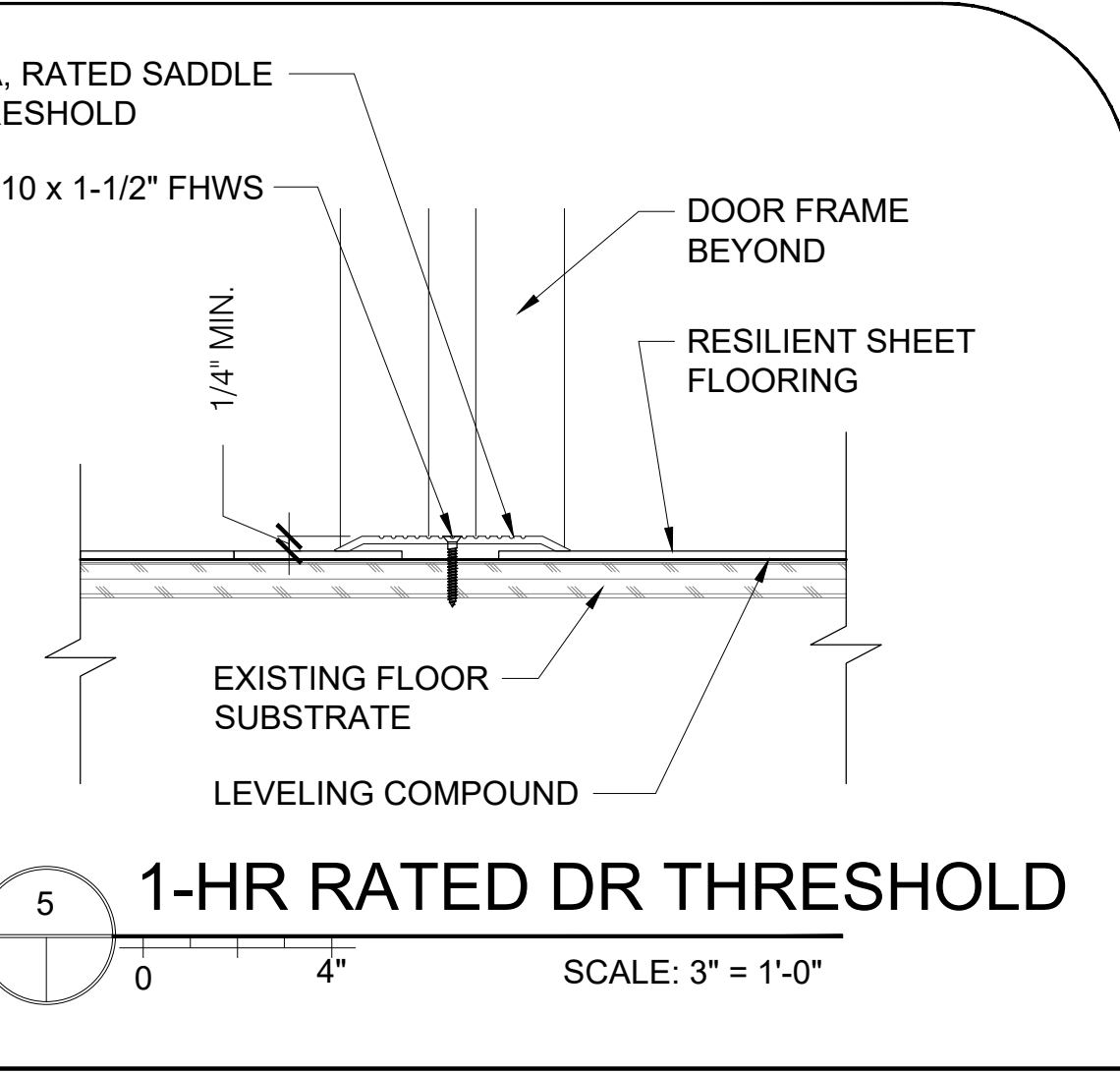
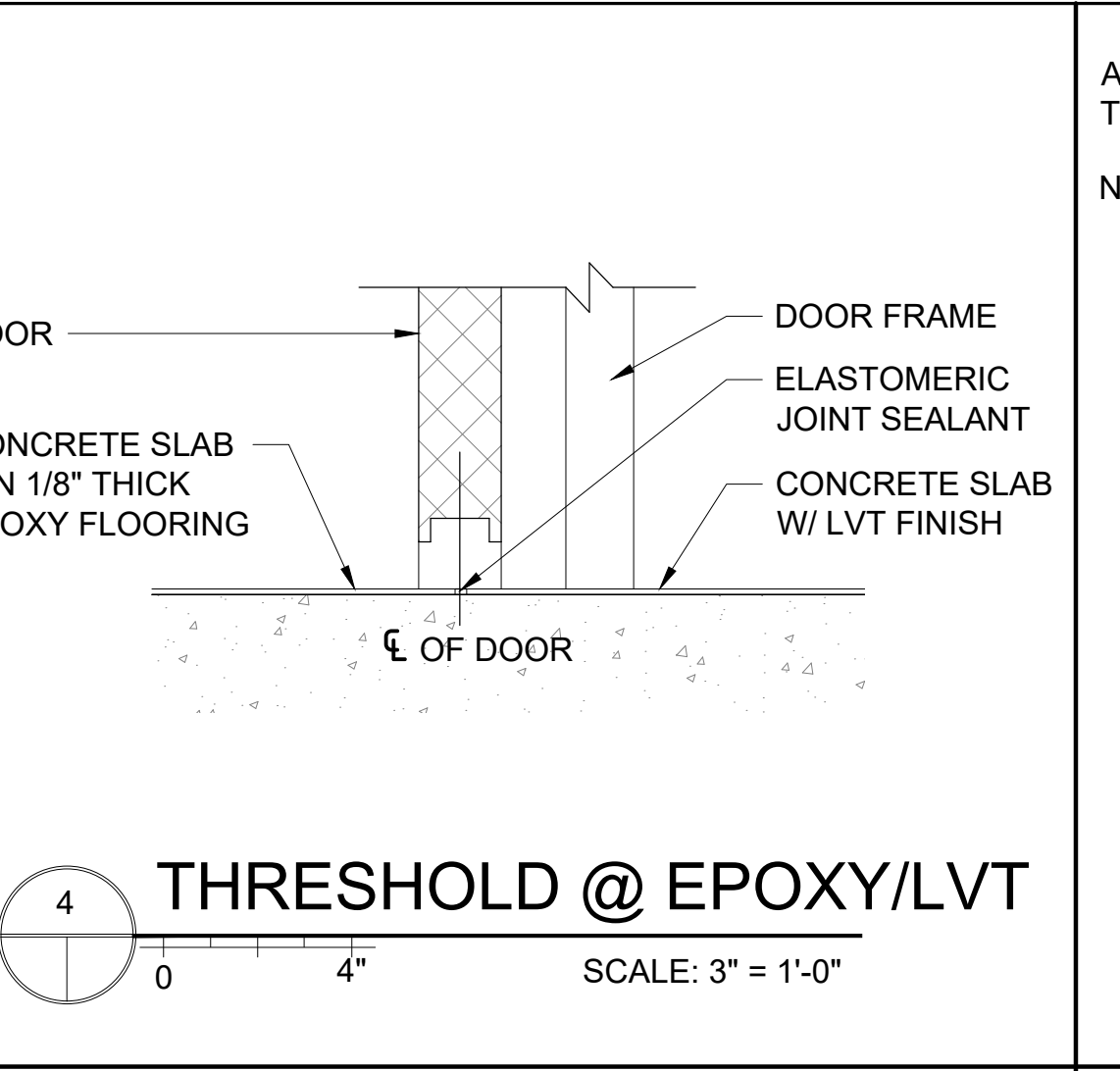
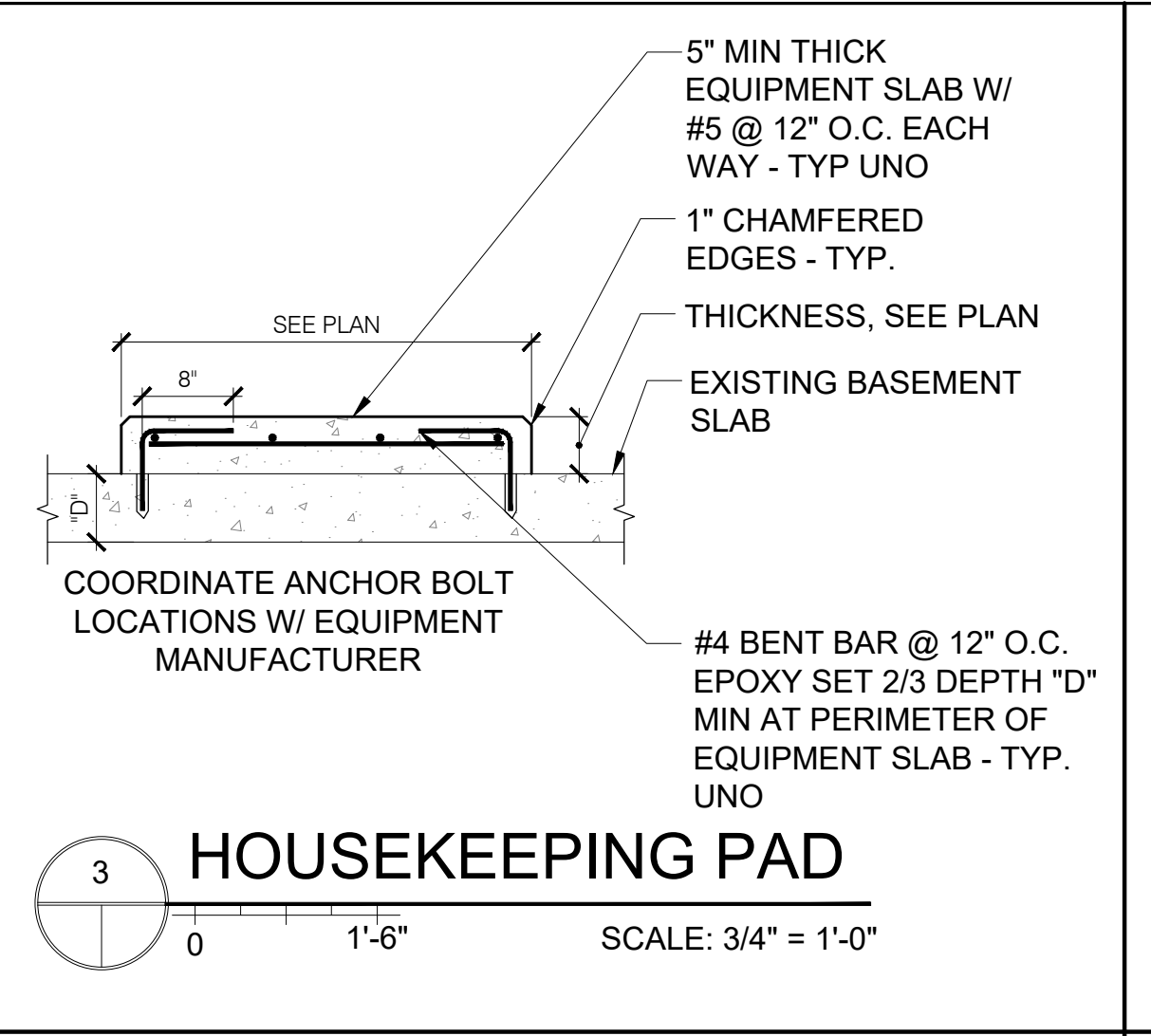
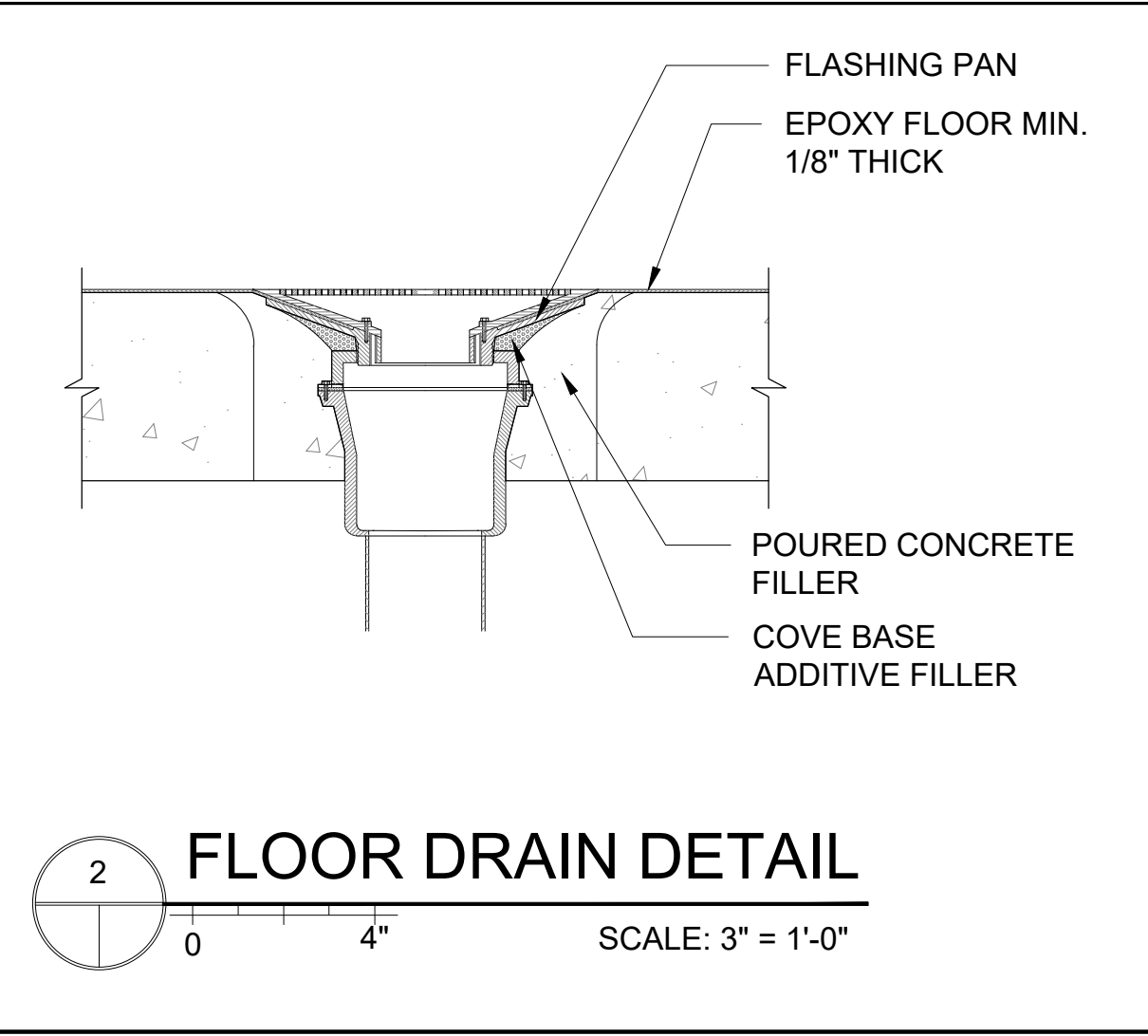
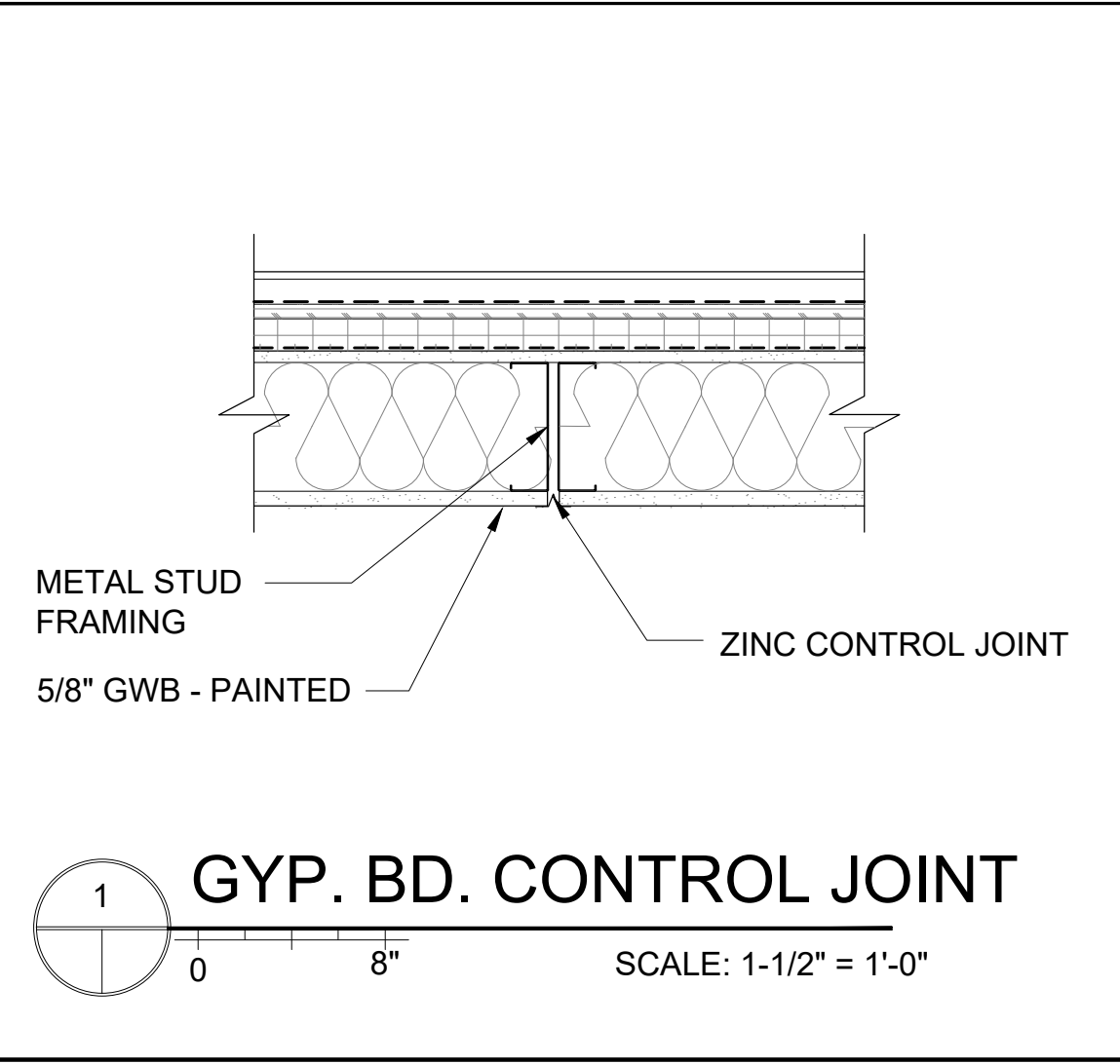
DRAWN BY **AEW**
SHEET TITLE
DETAILS - 5 of 6

ISSUE DATE **10/25/16**
SHEET SCALE
1/4" = 1'-0"

A

504