

COPYRIGHT: Reuse or reproduction of the contents of this document is not permitted without written permission of Bild Architecture LLC

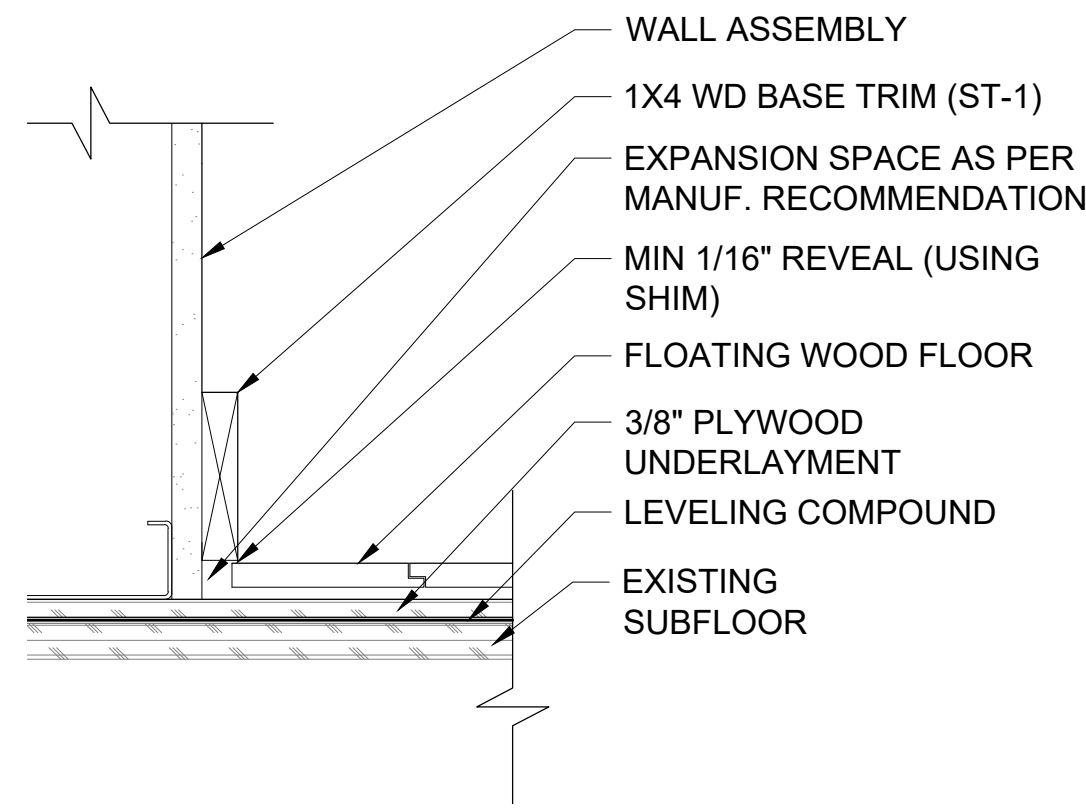

1 WOOD BASE/FLOOR DETAIL
SCALE: 3" = 1'-0"

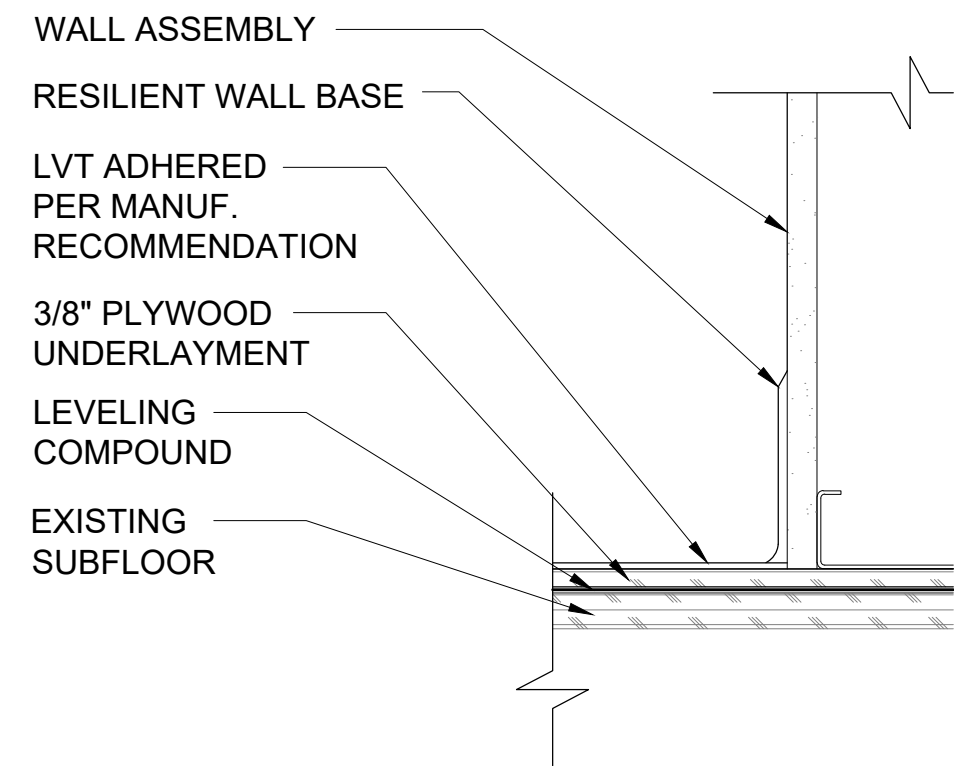

2 RWB/FLOOR DETAIL
SCALE: 3" = 1'-0"

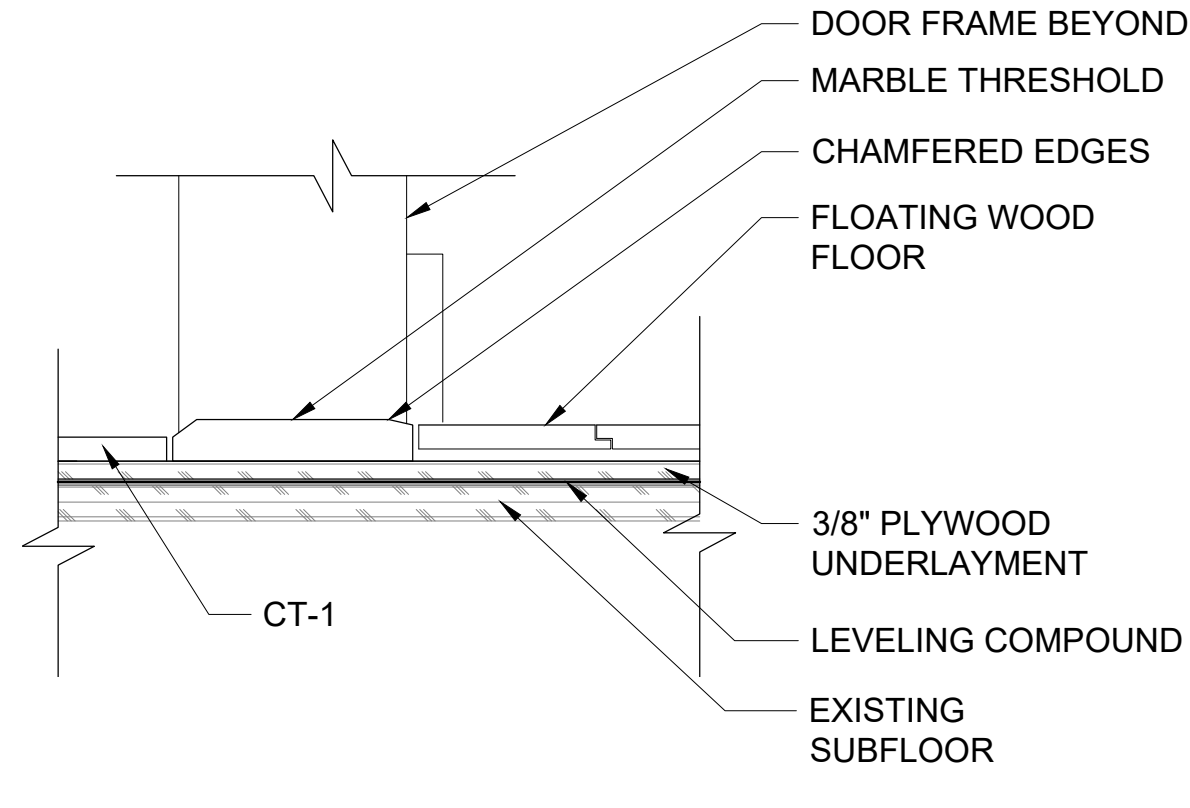

3 TILE/HARDWOOD TRANS.
SCALE: 3" = 1'-0"

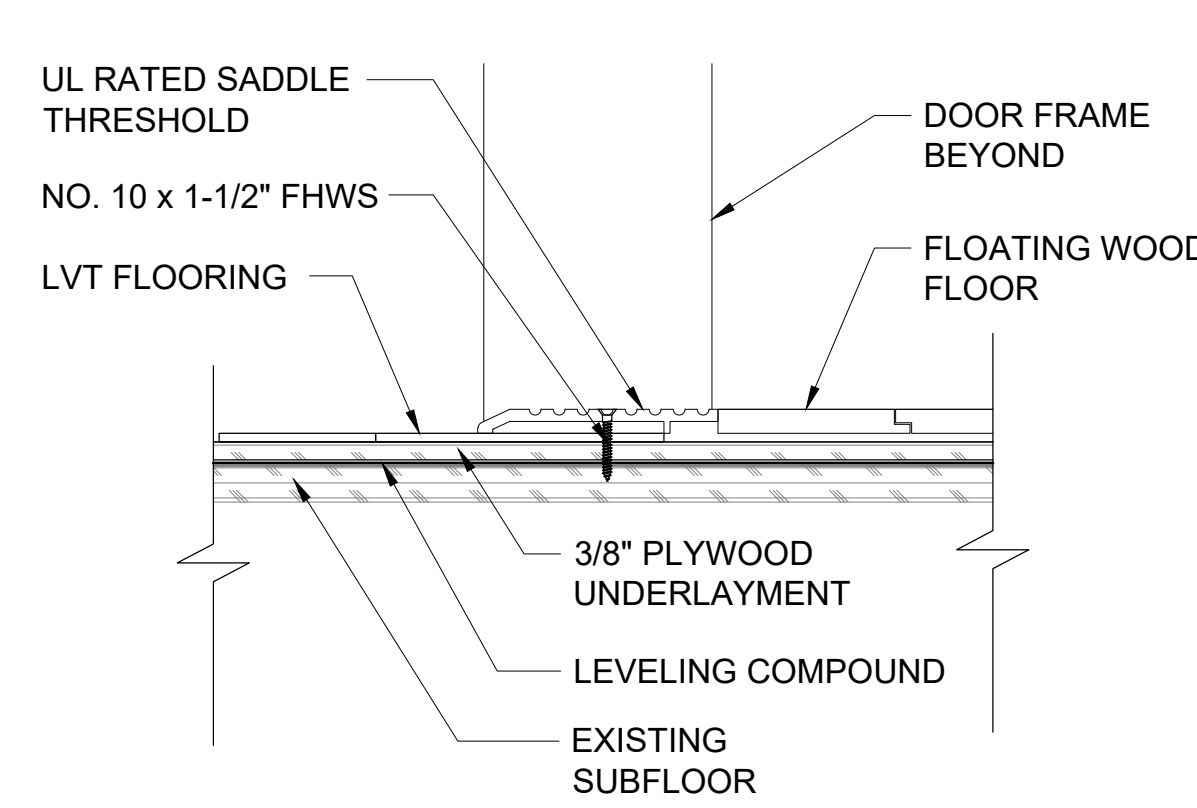

4 APT ENTRY DOOR SILL
SCALE: 3" = 1'-0"

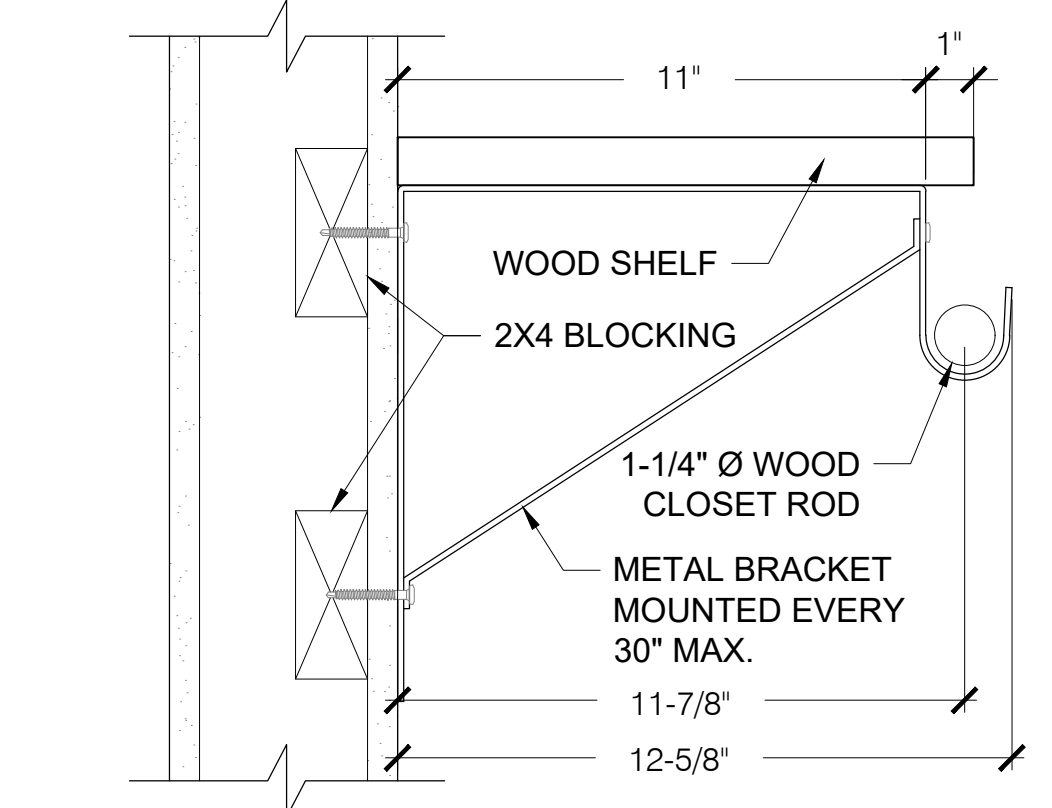

5 POLE & SHELF DETAIL
SCALE: 3" = 1'-0"

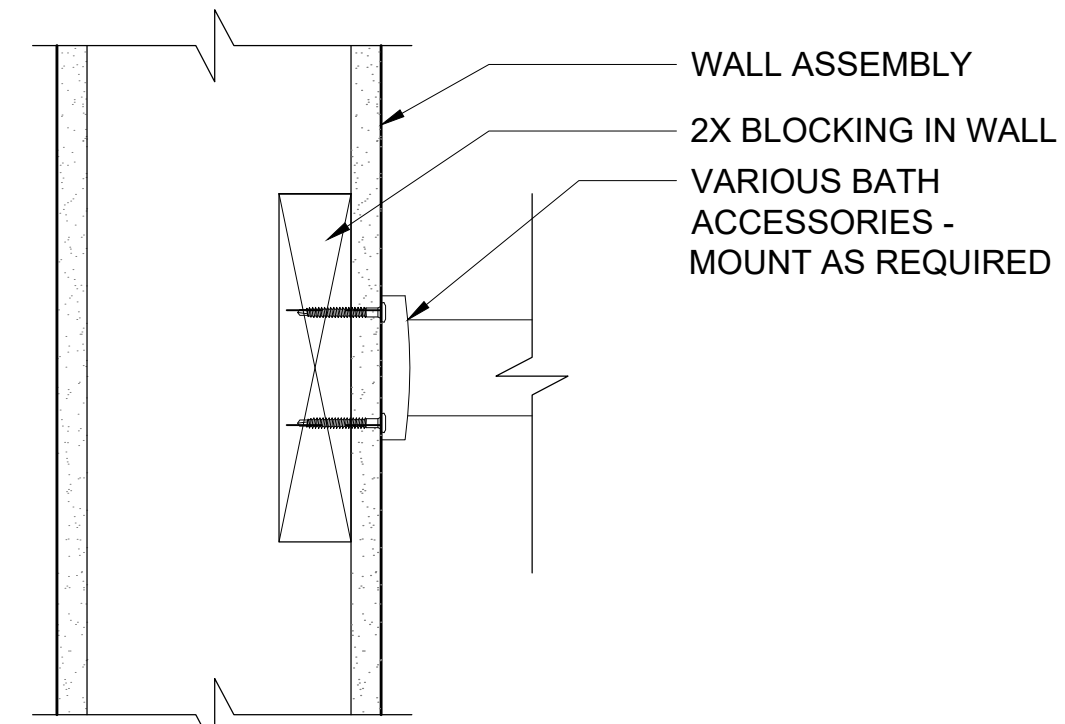

6 BATH ACCESSORY MNTING
SCALE: 1/2" = 1'-0"

7 NOT USED
SCALE: 3" = 1'-0"

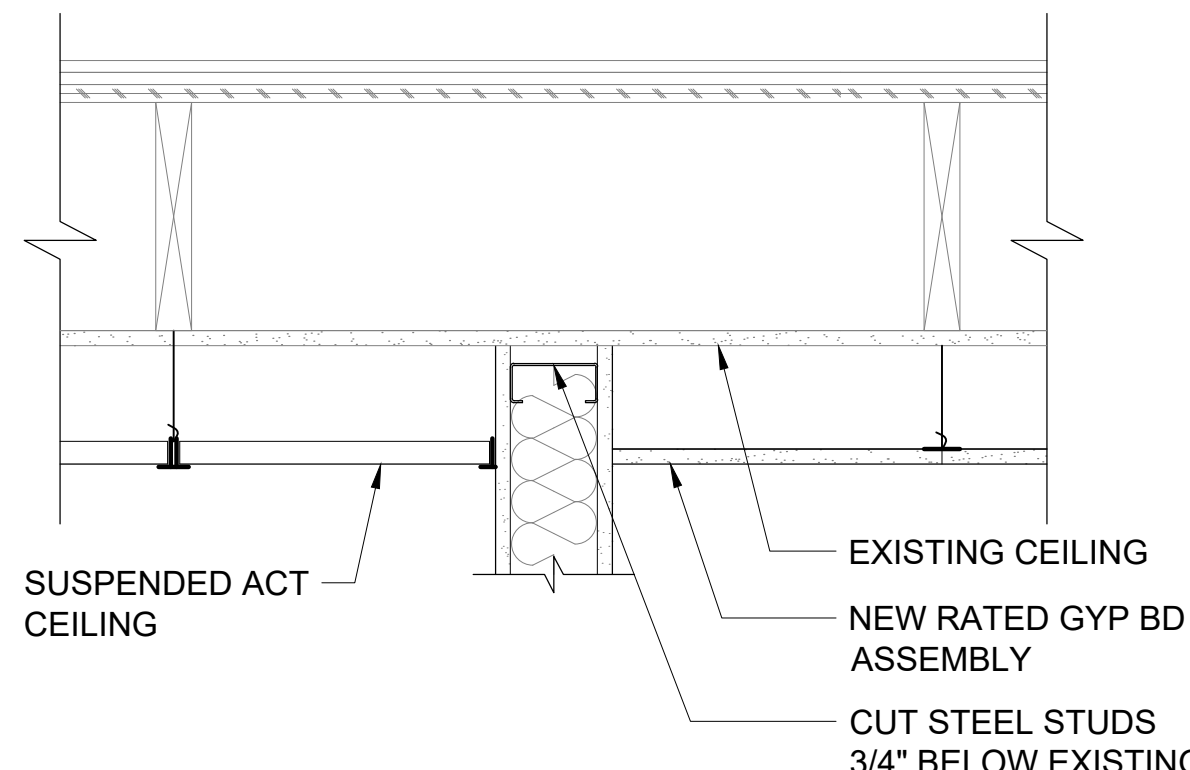

8 TOP OF RATED WALL
SCALE: 1-1/2" = 1'-0"

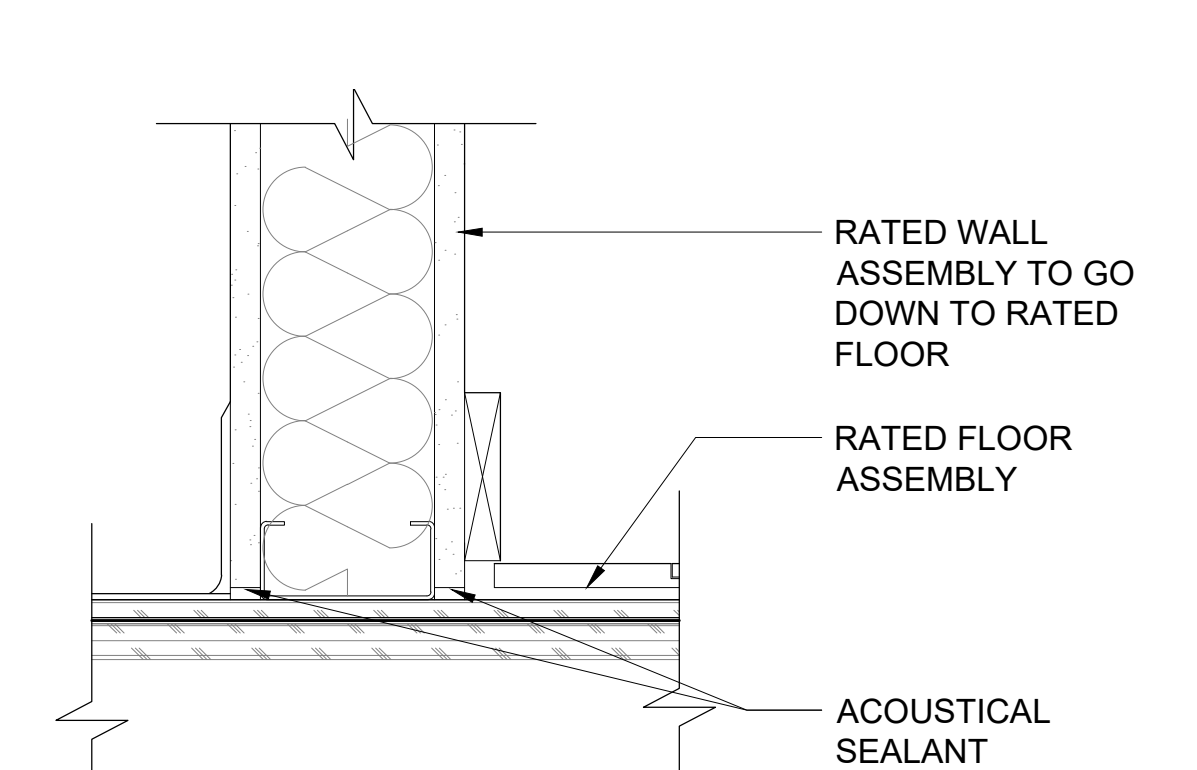

9 BOTTOM OF RATED WALL
SCALE: 3" = 1'-0"

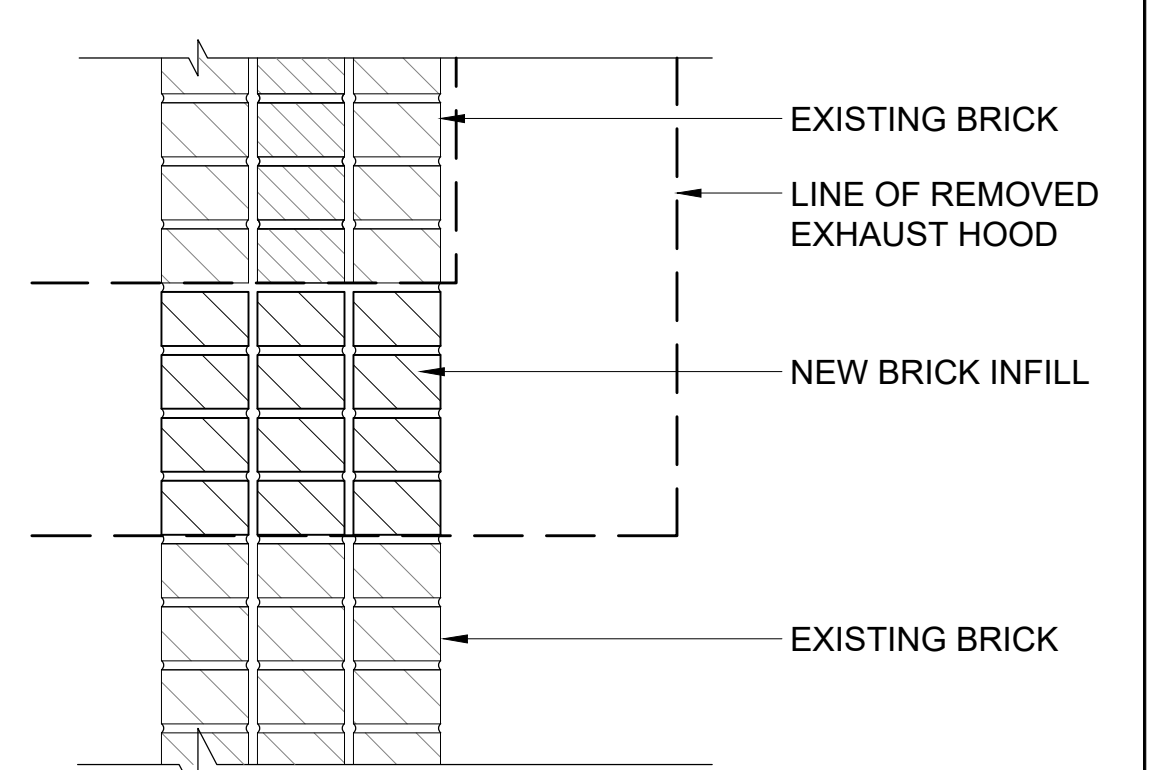

10 EXHAUST HOOD BRICK INFILL
SCALE: 3/8" = 1'-0"

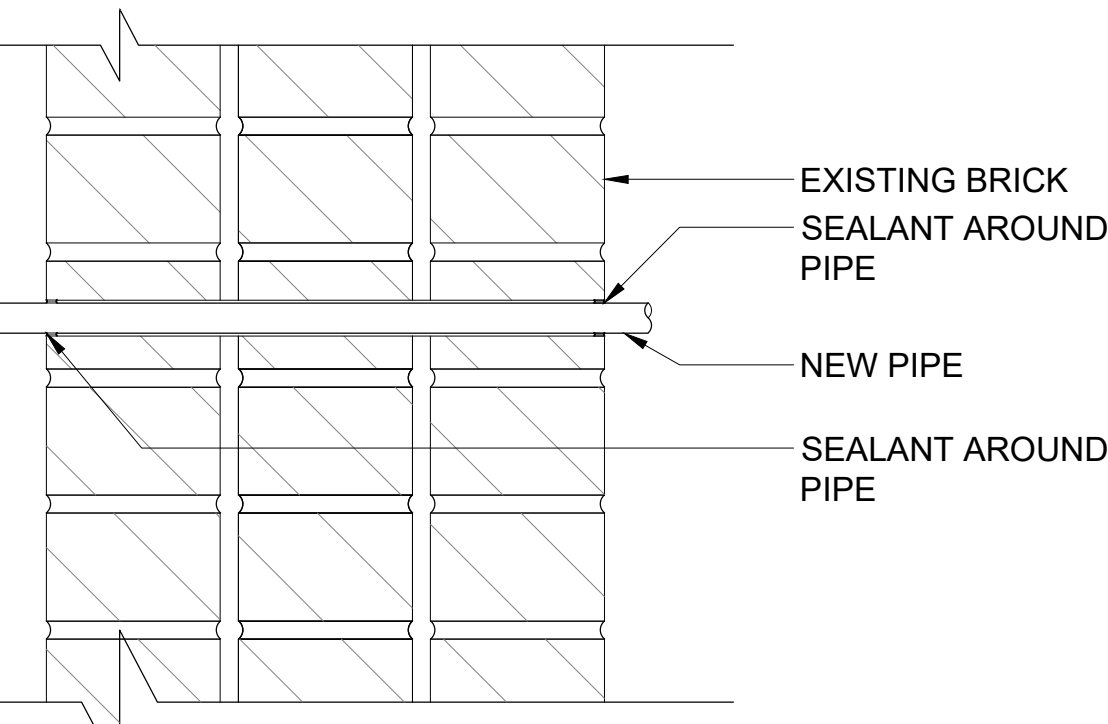

11 PIPE PENETRATION @ BRICK
SCALE: 3" = 1'-0"

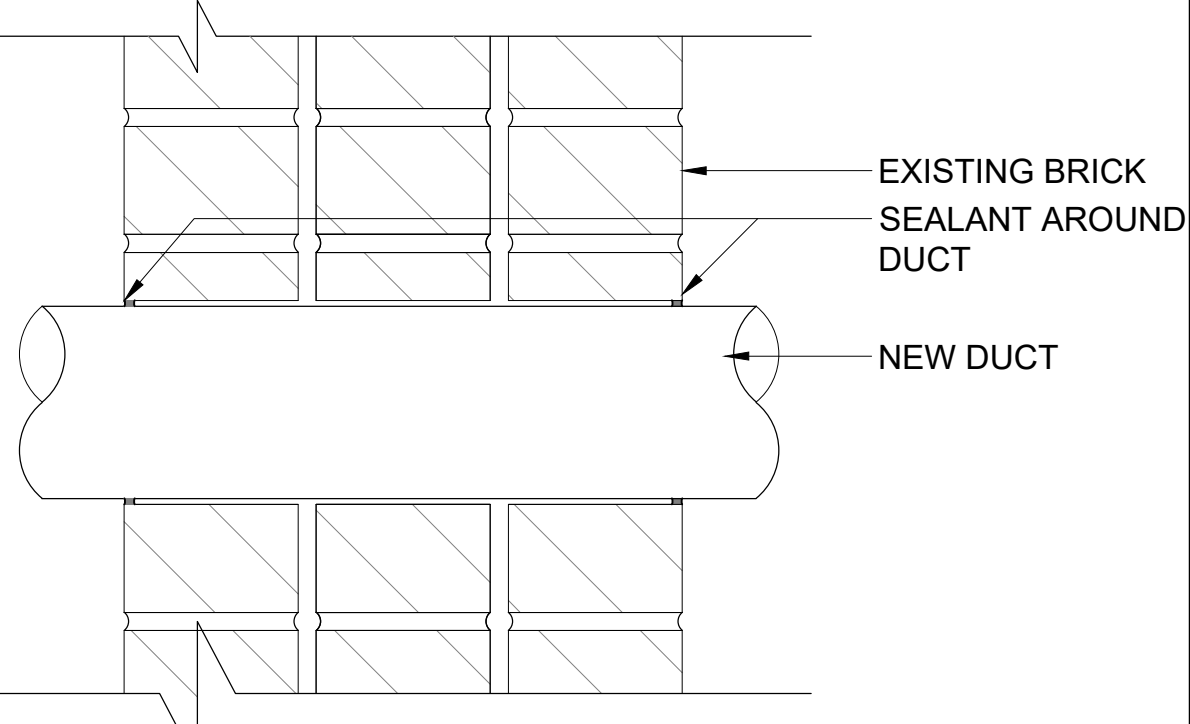

12 DUCT HOOD @ BRICK
SCALE: 3" = 1'-0"

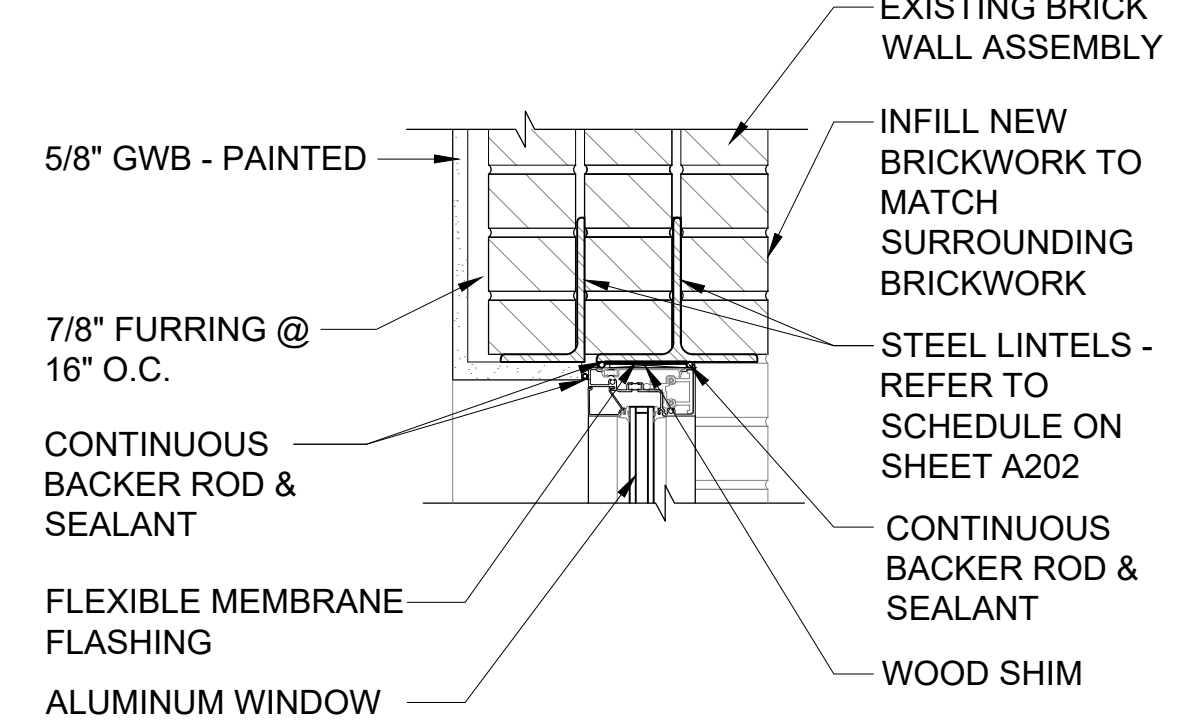

13 WINDOW "J" HEAD
SCALE: 1-1/2" = 1'-0"

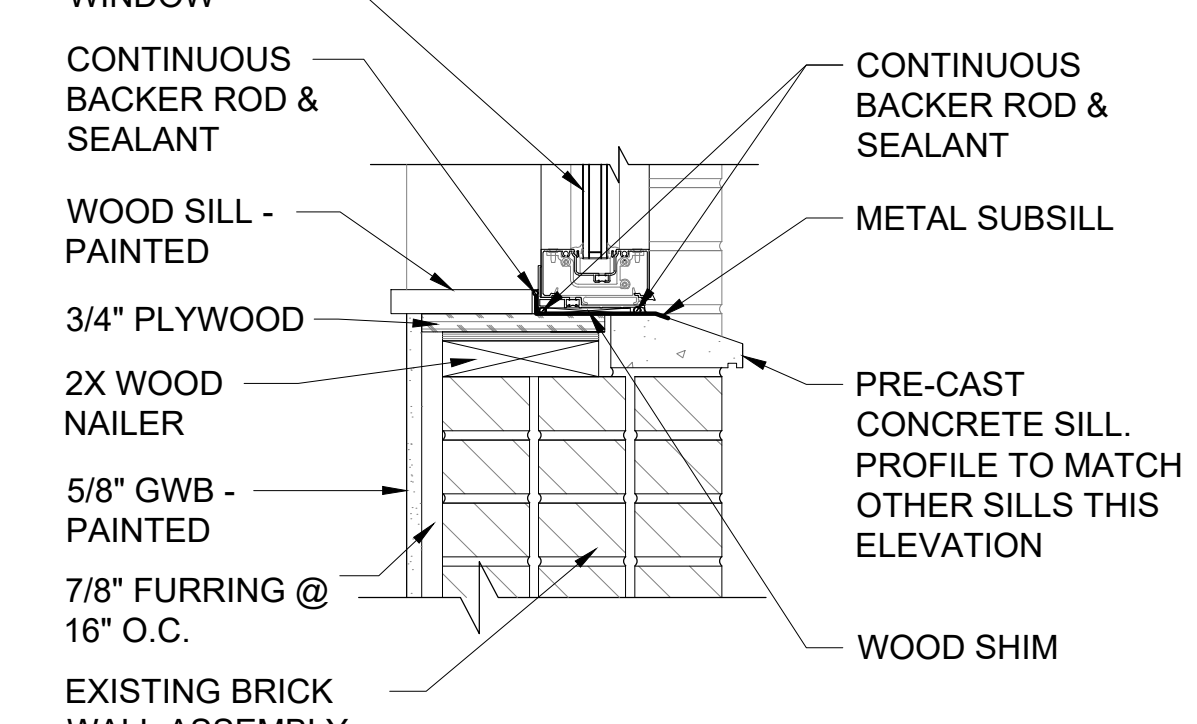

14 WINDOW "J" SILL
SCALE: 1-1/2" = 1'-0"

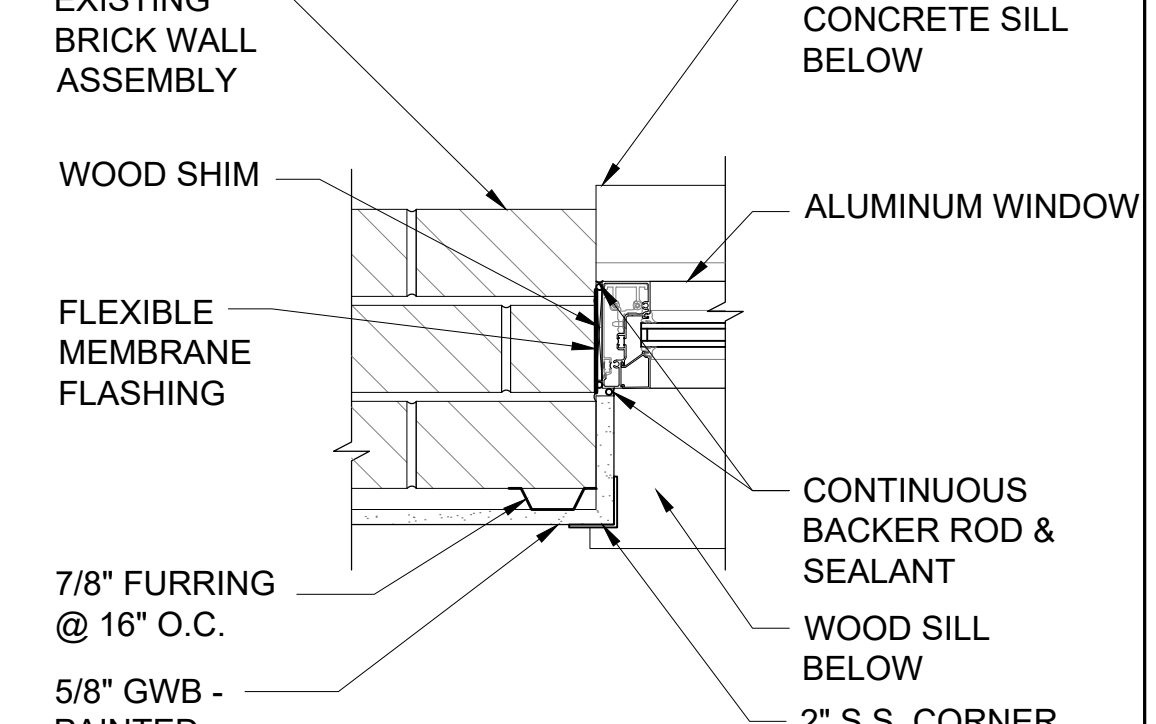

15 WINDOW "J" JAMB
SCALE: 1-1/2" = 1'-0"

16 NOT USED
SCALE: 1-1/2" = 1'-0"

17 NOT USED
SCALE: 3" = 1'-0"

18 NOT USED
SCALE: 1-1/2" = 1'-0"

19 NOT USED
SCALE: 1" = 1'-0"

20 NOT USED
SCALE: 3" = 1'-0"