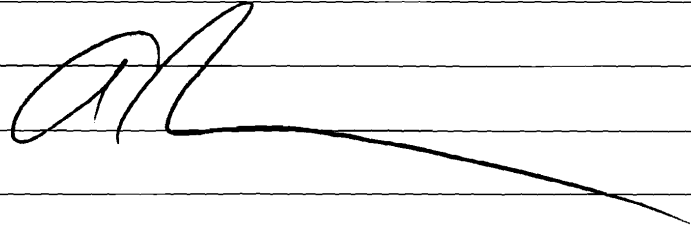

COMMENTS

1/3/01

Completed.

A large, stylized handwritten signature in black ink, appearing to be 'AL', with a long horizontal stroke extending to the right.

Inspection Record

	Type	Date
Foundation:	_____	_____
Framing:	_____	_____
Plumbing:	_____	_____
Final:	_____	_____
Other:	_____	_____

BUILDING PERMIT REPORT

DATE: 31 Aug 98 ADDRESS: 50 Alder ST, #33-C-016
 REASON FOR PERMIT: Remove / Construct STAIRS.
 BUILDING OWNER: Caroline Wicks
 CONTRACTOR: David DiPietro
 PERMIT APPLICANT: R
 USE GROUP R-3 BOCA 1996 CONSTRUCTION TYPE 5B

CONDITION(S) OF APPROVAL

This Permit is being issued with the understanding that the following conditions are met:

Approved with the following conditions: *1, *2, *10, *22

1. This permit does not excuse the applicant from meeting applicable State and Federal rules and laws.
2. Before concrete for foundation is placed, approvals from the Development Review Coordinator and Inspection Services must be obtained. (A 24 hour notice is required prior to inspection)
- 2.5 Foundation drain shall be placed around the perimeter of a foundation that consists of gravel or crushed stone containing not more than 10 percent material that passes through a No. 4 sieve. The drain shall extend a minimum of 12 inches beyond the outside edge of the footing. The thickness shall be such that the bottom of the drain is not higher than the bottom of the base under the floor, and that the top of the drain is not less than 6 inches above the top of the footing. The top of the drain shall be covered with an approved filter membrane material. Where a drain tile or perforated pipe is used, the invert of the pipe or tile shall not be higher than the floor elevation. The top of joints or top of perforations shall be protected with an approved filter membrane material. The pipe or tile shall be placed on not less than 2" of gravel or crushed stone, and shall be covered with not less than 6" of the same material. Section 1813.5.2
- 2.6 Foundations anchors shall be a minimum of 1 1/2" in diameter, 7" into the foundation wall, minimum of 12" from corners of foundation and a maximum 6'o.c. between bolts. (Section 2305.17)
3. Precaution must be taken to protect concrete from freezing. Section 1908.0
4. It is strongly recommended that a registered land surveyor check all foundation forms before concrete is placed. This is done to verify that the proper setbacks are maintained.
5. Private garages located beneath habitable rooms in occupancies in Use Group R-1, R-2, R-3 or I-1 shall be separated from adjacent interior spaces by fire partitions and floor/ceiling assembly which are constructed with not less than 1-hour fire resisting rating. Private garages attached side-by-side to rooms in the above occupancies shall be completely separated from the interior spaces and the attic area by means of 1/2 inch gypsum board or the equivalent applied to the garage means of 1/2 inch gypsum board or the equivalent applied to the garage side. (Chapter 4 Section 407.0 of the BOCA/1996)
6. All chimneys and vents shall be installed and maintained as per Chapter 12 of the City's Mechanical Code. (The BOCA National Mechanical Code/1993). Chapter 12 & NFPA 211
7. Sound transmission control in residential building shall be done in accordance with Chapter 12 section 1214.0 of the city's building code.
8. Guardrails & Handrails: A guardrail system is a system of building components located near the open sides of elevated walking surfaces for the purpose of minimizing the possibility of an accidental fall from the walking surface to the lower level. Minimum height all Use Groups 42", except Use Group R which is 36". In occupancies in Use Group A, B, H-4, I-1, I-2 M and R and public garages and open parking structures, open guards shall have balusters or be of solid material such that a sphere with a diameter of 4" cannot pass through any opening. Guards shall not have an ornamental pattern that would provide a ladder effect. (Handrails shall be a minimum of 34" but not more than 38". Use Group R-3 shall not be less than 30", but not more than 38".) Handrail grip size shall have a circular cross section with an outside diameter of at least 1 1/4" and not greater than 2". (Sections 1021 & 1022.0)
9. Headroom in habitable space is a minimum of 7'6". (Section 1204.0)
10. Stair construction in Use Group R-3 & R-4 is a minimum of 10" tread and 7 3/4" maximum rise. All other Use group minimum 11" tread, 7" maximum rise.(Section 1014.0)
11. The minimum headroom in all parts of a stairway shall not be less than 80 inches. (6' 8") 1014.4
12. Every sleeping room below the fourth story in buildings of use Groups R and I-1 shall have at least one operable window or exterior door approved for emergency egress or rescue. The units must be operable from the inside without the use of special knowledge or separate tools. Where windows are provided as means of egress or rescue they shall have a sill height

David D. DiPietro General Contractor

Top Quality Workmanship • Free Estimates • Commercial & Residential

221 Virginia Street • Portland, Maine • (207) 797-9531

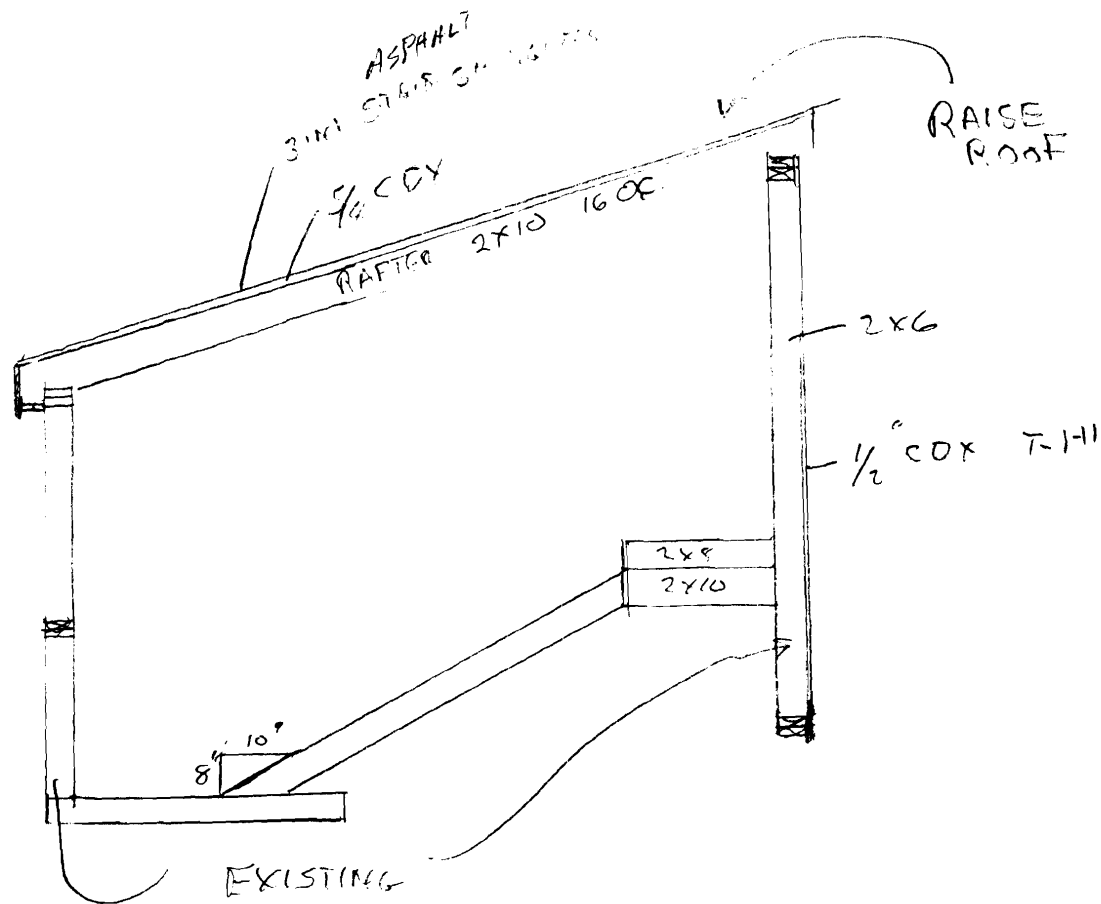
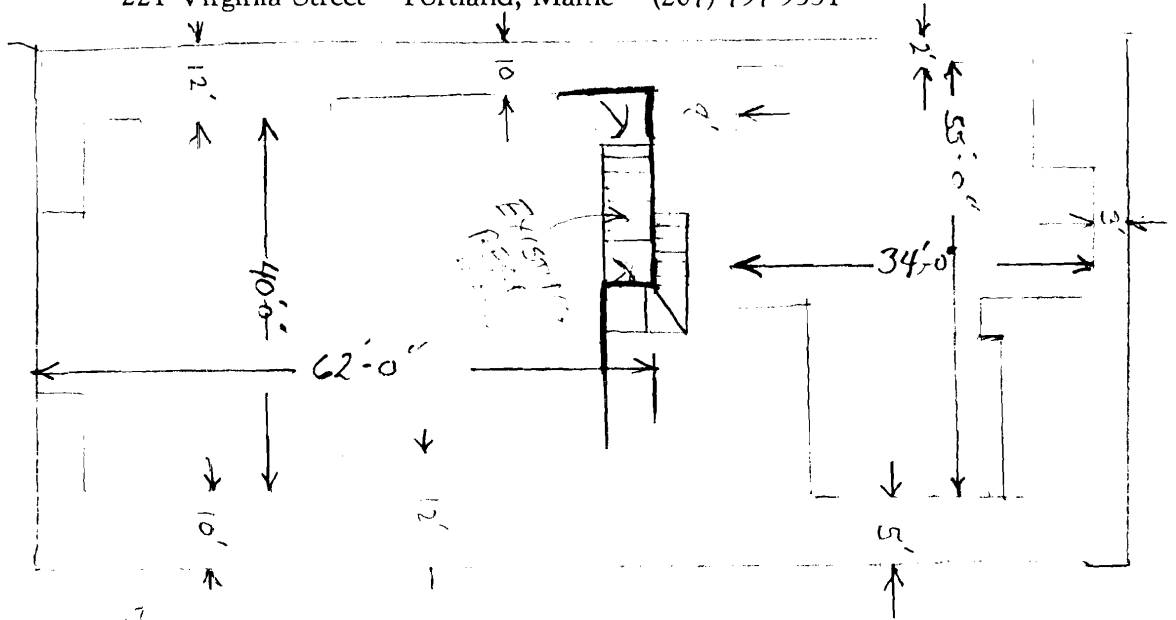

not more than 44 inches (1118mm) above the floor. All egress or rescue windows from sleeping rooms shall have a minimum net clear opening height dimension of 24 inches (610mm). The minimum net clear opening width dimension shall be 20 inches (508mm), and a minimum net clear opening of 5.7 sq. ft. (Section 1018.6)

13. Each apartment shall have access to two (2) separate, remote and approved means of egress. A single exit is acceptable when it exits directly from the apartment to the building exterior with no communications to other apartment units. Section 1010.1

14. All vertical openings shall be enclosed with construction having a fire rating of at least one (1)hour, including fire doors with self closer's. (Over 3 stories in height requirements for fire rating is two (2) hours.) Section 710.0

15. The boiler shall be protected by enclosing with (1) hour fire-rated construction including fire doors and ceiling, or by providing automatic extinguishment. Table 302.1.1

16. All single and multiple station smoke detectors shall be of an approved type and shall be installed in accordance with the provisions of the City's Building Code Chapter 9, Section 19, 920.3.2 (BOCA National Building Code/1996), and NFPA 101 Chapter 13 & 19. (Smoke detectors shall be installed and maintained at the following locations):

- In the immediate vicinity of bedrooms
- In all bedrooms
- In each story within a dwelling unit, including basements

In addition to the required AC primary power source, required smoke detectors in occupancies in Use Groups R-2, R-3 and I-1 shall receive power from a battery when the AC primary power source is interrupted. (Interconnection is required) Section 920.3.2

17. A portable fire extinguisher shall be located as per NFPA #10. They shall bear the label of an approved agency and be of an approved type. Section 921.0

18. The Fire Alarm System shall be maintained to NFPA #72 Standard.

19. The Sprinkler System shall maintained to NFPA #13 Standard.

20. All exit signs, lights, and means of egress lighting shall be done in accordance with Chapter 10 Section & Subsections 1023. & 1024. Of the City's building code. (The BOCA National Building Code/1996)

21. Section 25-135 of the Municipal Code for the City of Portland states, "No person or utility shall be granted a permit to excavate or open any street or sidewalk from the time of November 15 of each year to April 15 of the following year".

22. The builder of a facility to which Section 4594-C of the Maine State Human Rights Act Title 5 MRSA refers, shall obtain a certification from a design professional that the plans commencing construction of the facility, the builder shall submit the certification to the Division of Inspection Services.

23. Ventilation shall meet the requirements of Chapter 12 Sections 1210. Of the City's Building Code. (crawl spaces & attics)

24. All electrical, plumbing and HVAC permits must be obtained by a Master Licensed holders of their trade.

25. All requirements must be met before a final Certificate of Occupancy is issued.

26. All building elements shall meet the fastening schedule as per Table 2305.2 of the City's Building Code. (The BOCA National Building Code/1996).

27. Ventilation of spaces within a building shall be done in accordance with the City's Mechanical Code (The BOCA National Mechanical Code/1993). (Chapter M-16)

28. Please read and implement the attached Land Use-Zoning report requirements.

- 29. _____
- 30. _____
- 31. _____
- 32. _____

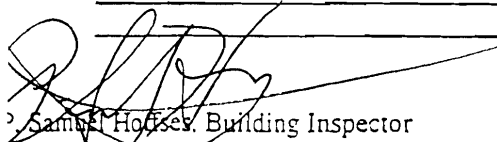
Samuel Hodsey, Building Inspector

cc: Lt. McDougall, PFD
Marge Schmuckal, Zoning Administrator