

FAN #1 NCA24HPFA - EXHAUST FAN

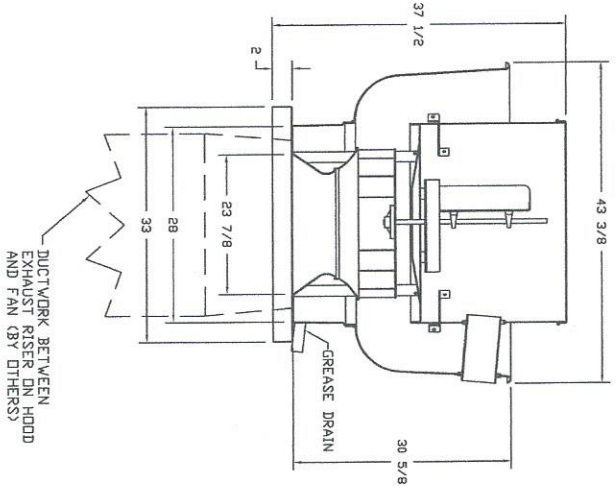

FEATURES:

- ROOF MOUNTED FANS
- RESISTANT MODEL
- UL705 AND UL782
- AHA SOUND AND AIR CERTIFIED
- WIRING FROM MOTOR TO DISCONNECT SWITCH
- WEATHERPROOF DISCONNECT
- HIGH HEAT OPERATION 300°F (149°C)
- GREASE CLASSIFICATION TESTING

NORMAL TEMPERATURE TEST

EXHAUST FAN MUST OPERATE CONTINUOUSLY WHILE EXHAUSTING AIR AT 300°F (149°C) UNTIL ALL FAN PARTS HAVE REACHED THEIR DESIGN TEMPERATURE WITHOUT ANY DEGRADATING EFFECTS TO THE FAN WHICH WOULD CAUSE UNSAFE OPERATION.

ABNORMAL FLARE-UP TEST

EXHAUST FAN MUST OPERATE CONTINUOUSLY WHILE EXHAUSTING BURNING GREASE VAPORS AT 600°F (316°C) FOR A PERIOD OF 15 MINUTES WITHOUT THE FAN BECOMING DAMAGED TO ANY EXTENT THAT COULD CAUSE AN UNSAFE CONDITION.

OPTIONS

- GREASE BOX
- 3 YEAR EXTENDED MOTOR WARRANTY
- EXTRA SET OF BELTS
- FAN BASE CERAMIC SEAL - FOR GREASE DUCTS

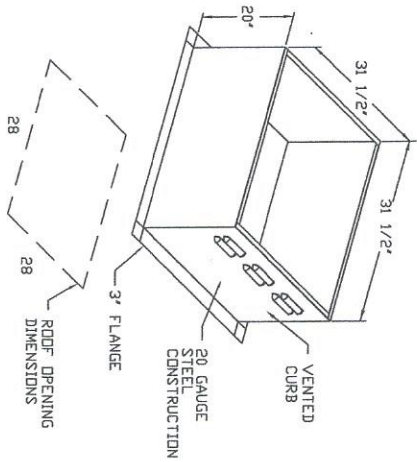

CUSTOMER APPROVAL TO MANUFACTURE:

Approved as Noted

Approved with NO Exception Taken

Revise and Resubmit

SIGNATURE _____ Date _____

Your Title _____



JOB Portland Job #2	LOCATION Biddeford, ME,	JOB # 206
DATE 6/9/2014	DRAWN BY BFC	SCALE 3/8" =
DWG # 4		
REV.		