

1 | ELEVATION
SCALE: 3/16" = 1'-0"

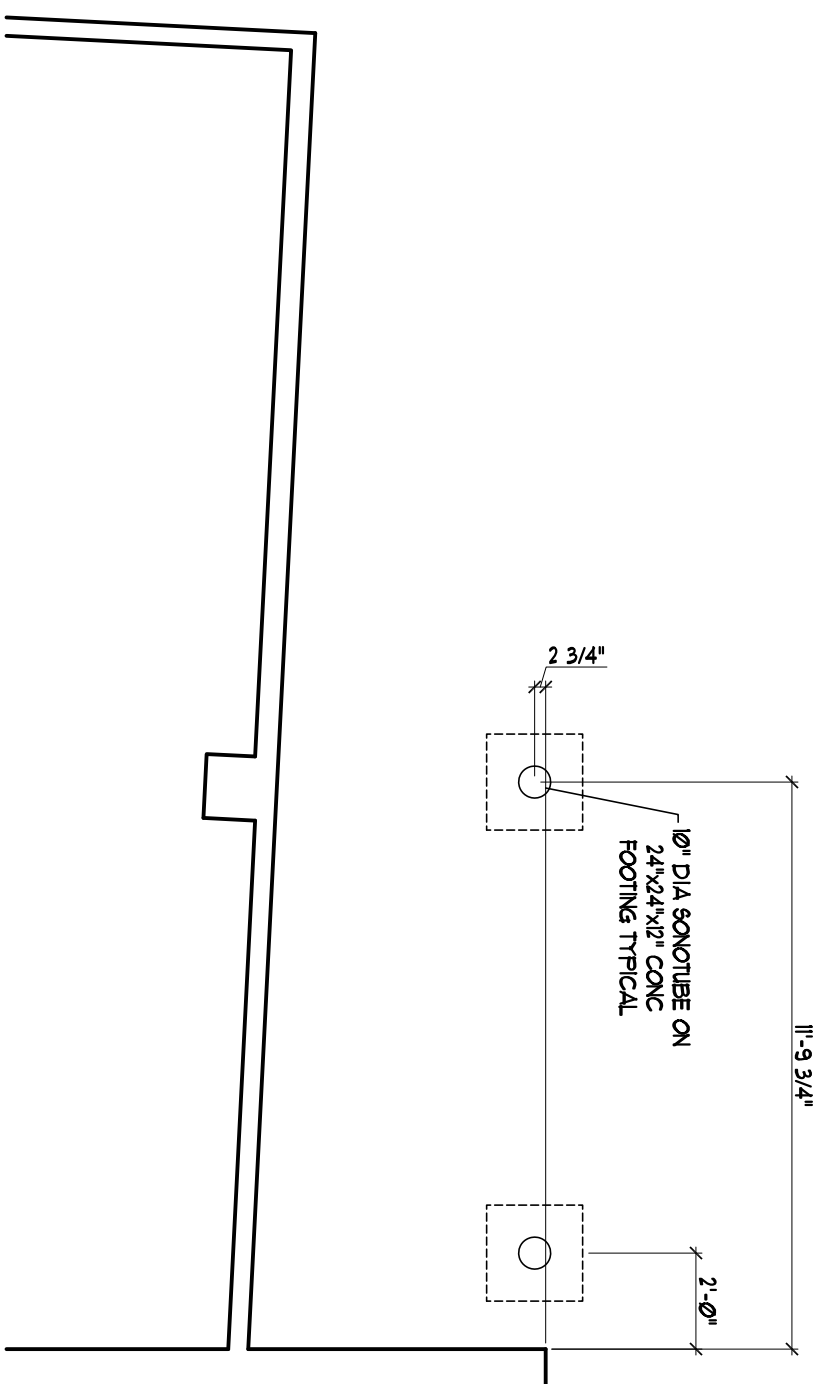

3 | FOUNDATION PLAN
SCALE: 1/4" = 1'-0"

- HARDWARE SCHEDULE
(SIMPSON STRONGTIE UNLESS NOTED)
- POST BASE: AB166 WITH 1/2" EXPANSION ANCHOR
 - POST CAPS: (2) ACE4
 - INTERMEDIATE: AC6
 - ① TYPICAL JOIST - LUB28
 - ② TYPICAL DOUBLE JOIST - H4228-2
 - ③ 1/2" DIA x 6 1/2" DYNABOLT GLEIVE BY TML RAINBOWHEAD SPACED AT 17" STaggered 1 1/2" FROM TOP & BOTTOM
 - ④ 1/2" DIA x 6 1/2" DYNABOLT GLEIVE BY TML RAINBOWHEAD AT BOTTOM HALF OF LEDGER (INTO CONC) SPACED AT 7" LOCATED 1 1/2" FROM BOTTOM AND (2) 1/2" DIA WALLS AT TOP HALF OF LEDGER AND EACH STUD
 - ⑤ RAFTERS - H25A

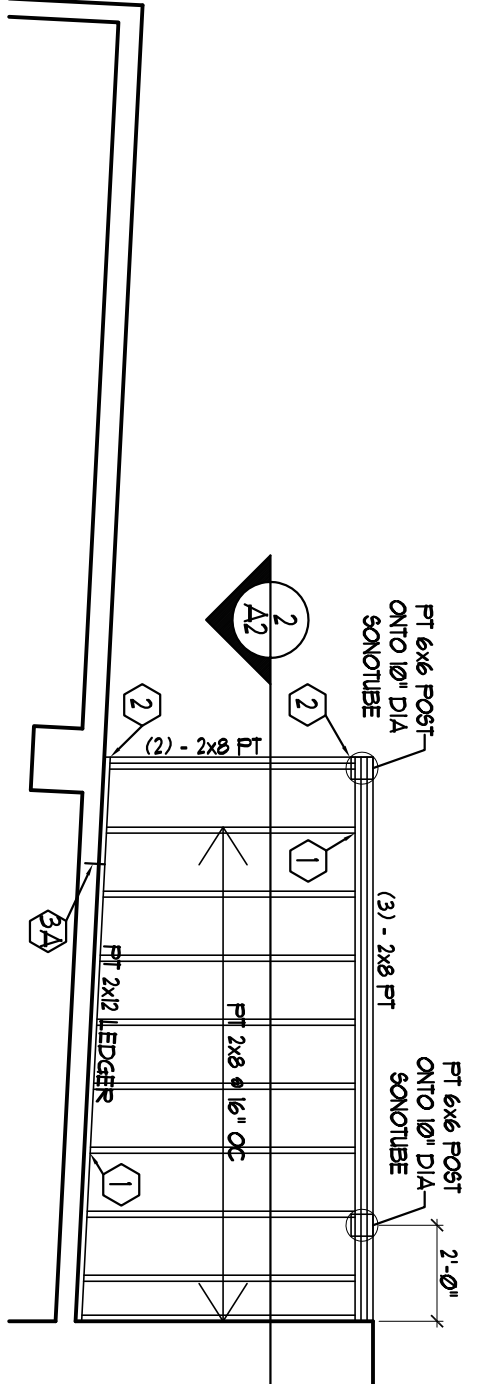

4 | FLOOR FRAMING PLAN
SCALE: 1/4" = 1'-0"

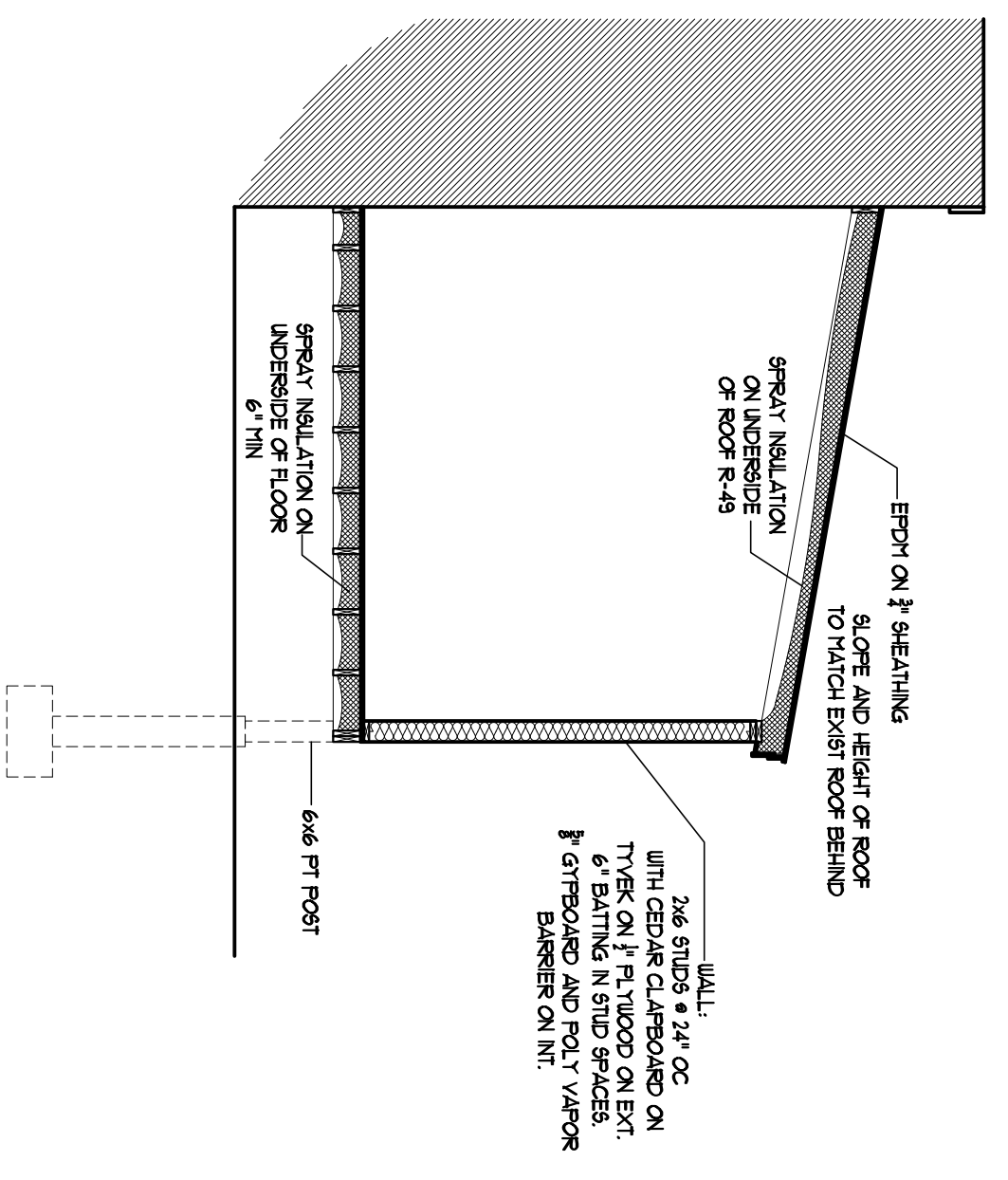

2 | SECTION
SCALE: 1/4" = 1'-0"

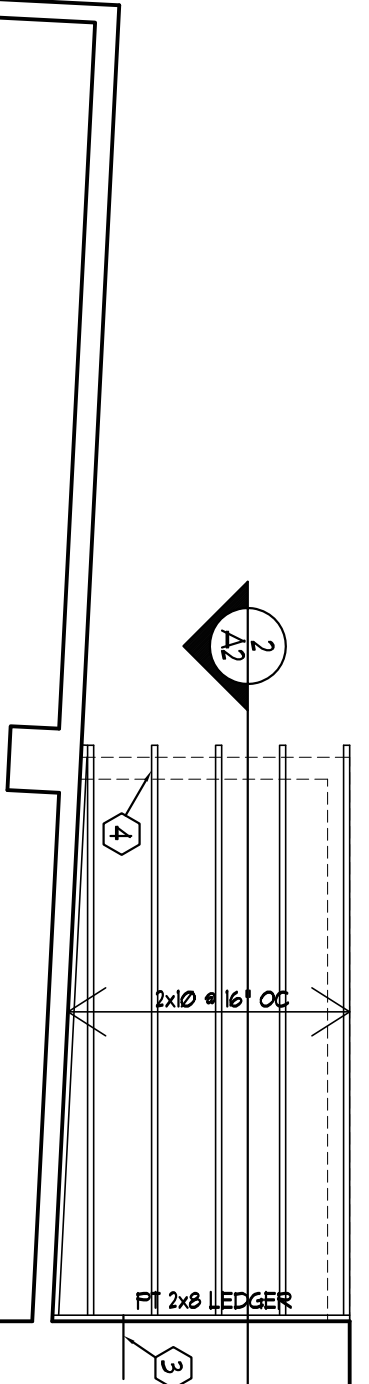

5 | ROOF FRAMING PLAN
SCALE: 1/4" = 1'-0"