

MERIT LT SYSTEM

Vistawall Merit LT system consists of a range of window and door types and is ideal for residential developments and low rise where the specifier demands a competitively priced system.

The Merit LT System has been designed to provide long term high levels of comfort for the user.



Non thermal framework is available in:-

- Sliding systems
- Inward and outward opening doors
- Fixed windows

Thermal framework is available in:-

- Sliding systems
- Inward and outward opening windows
- Fixed windows

Merit LT sliding windows have continuous pile seals containing a polypropylene fin to provide superior weatherproofing. The system is designed and fabricated to ensure that there is a continuous barrier between the outside and inside to minimise air infiltration, particularly at the framework intersections. Two, three or four panel windows can be supplied in any configuration of sliding and fixed panels.

All doors are rebated to provide an airtight perimeter seal and additional security. Standard Vistawall hardware is normally used - or suitable special hardware may be fitted.

Fixed windows can either be integrated with the doors and sliding windows or used as individual units.

All visible aluminium is finished in either painted or anodized finish to meet international standards.

The system is designed to accommodate 24mm glass thickness. Other thicknesses may also be accommodated.

All gaskets and setting blocks are made from extruded EPDM in a hardness to suit the application. Fasteners are 300 series stainless steel.

Please ask about other window and door types from the Vistawall Merit Range.



VISTAWALL INTERNATIONAL

MERIT LT NON THERMAL

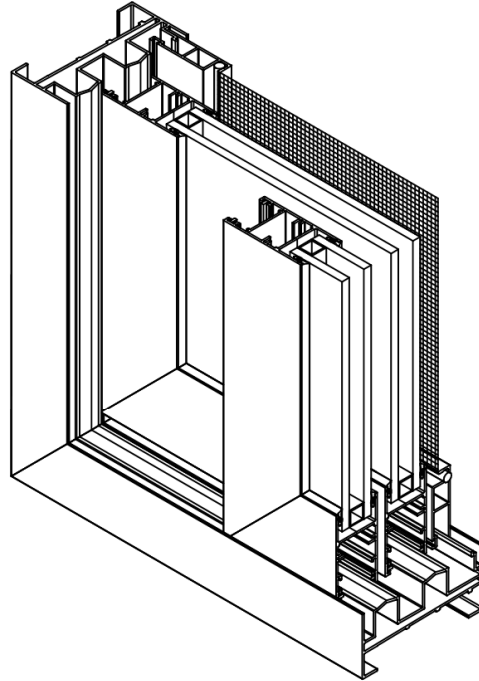

SLIDING

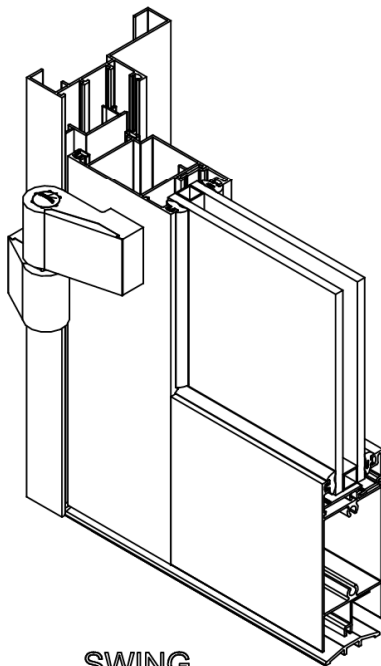

SWING

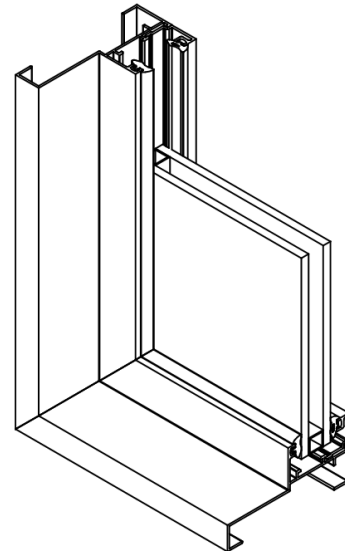

FIXED

VISTAWALL INTERNATIONAL

P.O.Box 18040, Dubai, United Arab Emirates.

Tel: + 971 4 886 0691 Fax:+971 4 886 0720 Email: info@vistawall.ae

VISTAWALL INTERNATIONAL

MERIT LT THERMAL

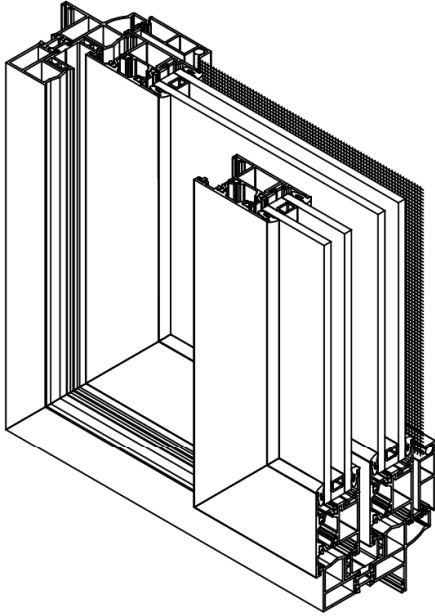

SLIDING

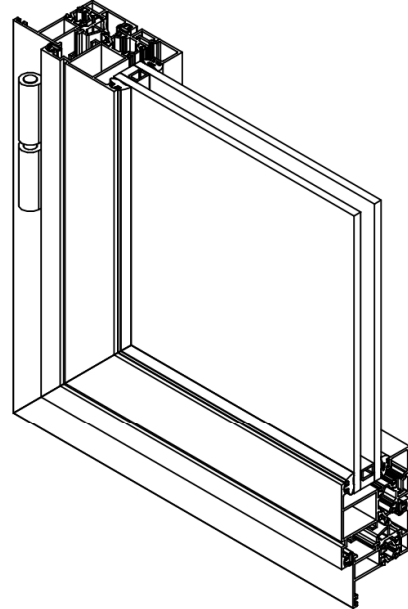

OUTWARD SWING

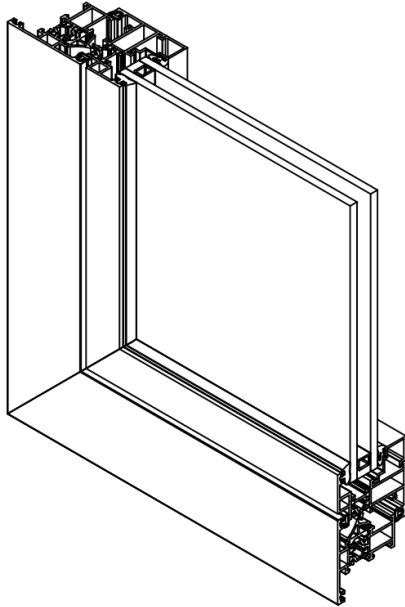

INWARD SWING

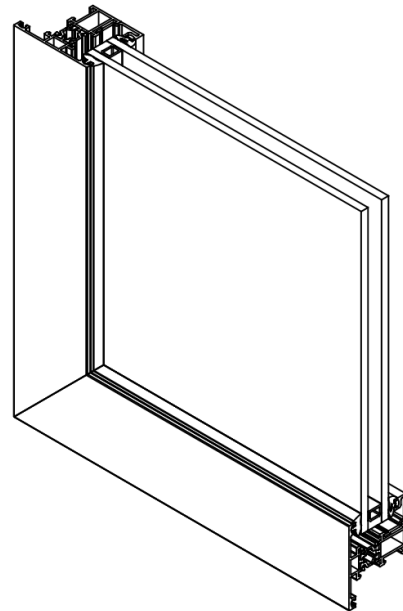

FIXED

VISTAWALL INTERNATIONAL

P.O.Box 18040, Dubai, United Arab Emirates.

Tel: + 971 4 886 0691 Fax:+971 4 886 0720 Email: info@vistawall.ae