

15 CARPET TO CARPET DETAIL
SCALE: 6" = 1'-0"

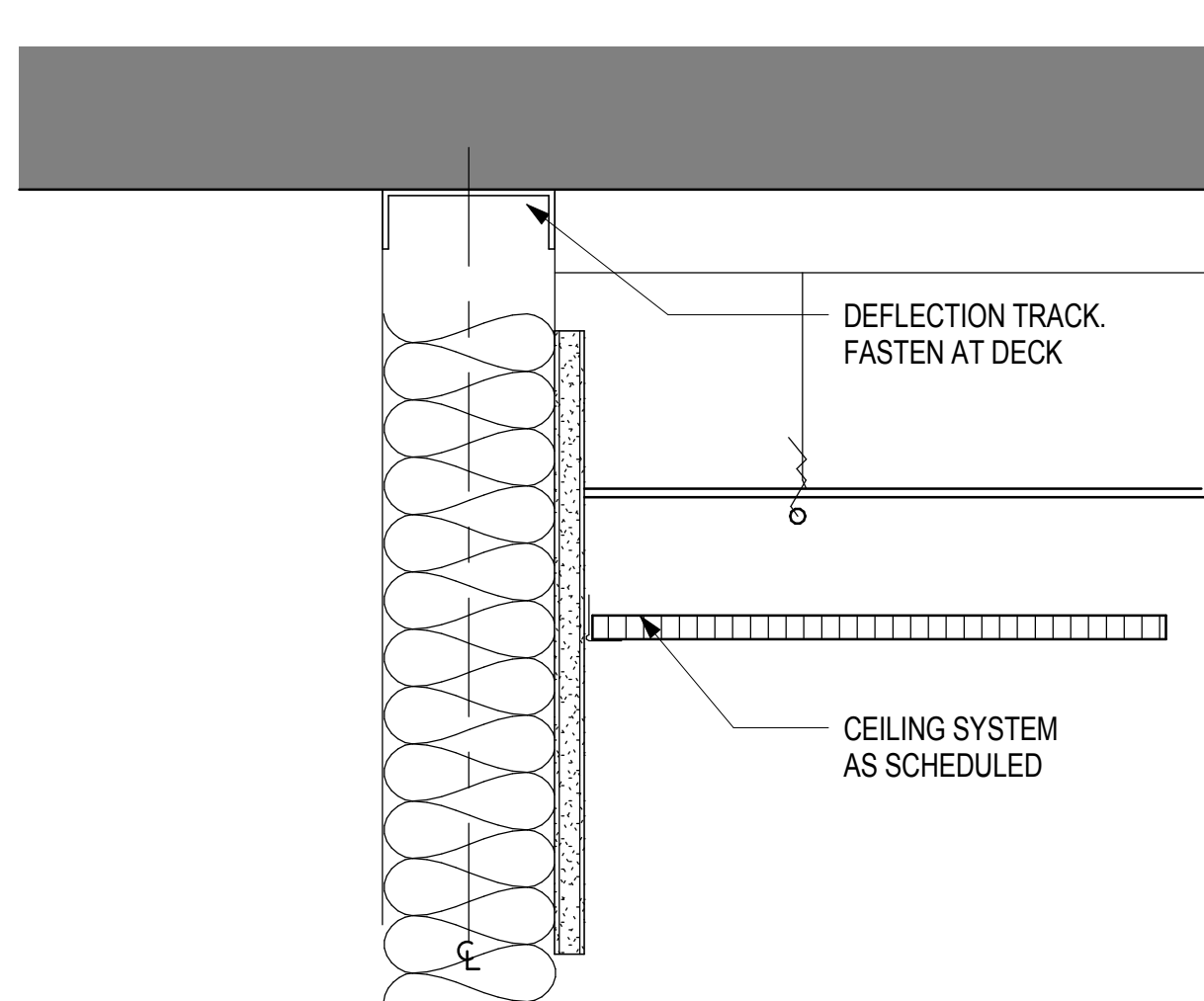

10 HEAD DETAIL - 'HD-01'
SCALE: 3" = 1'-0"

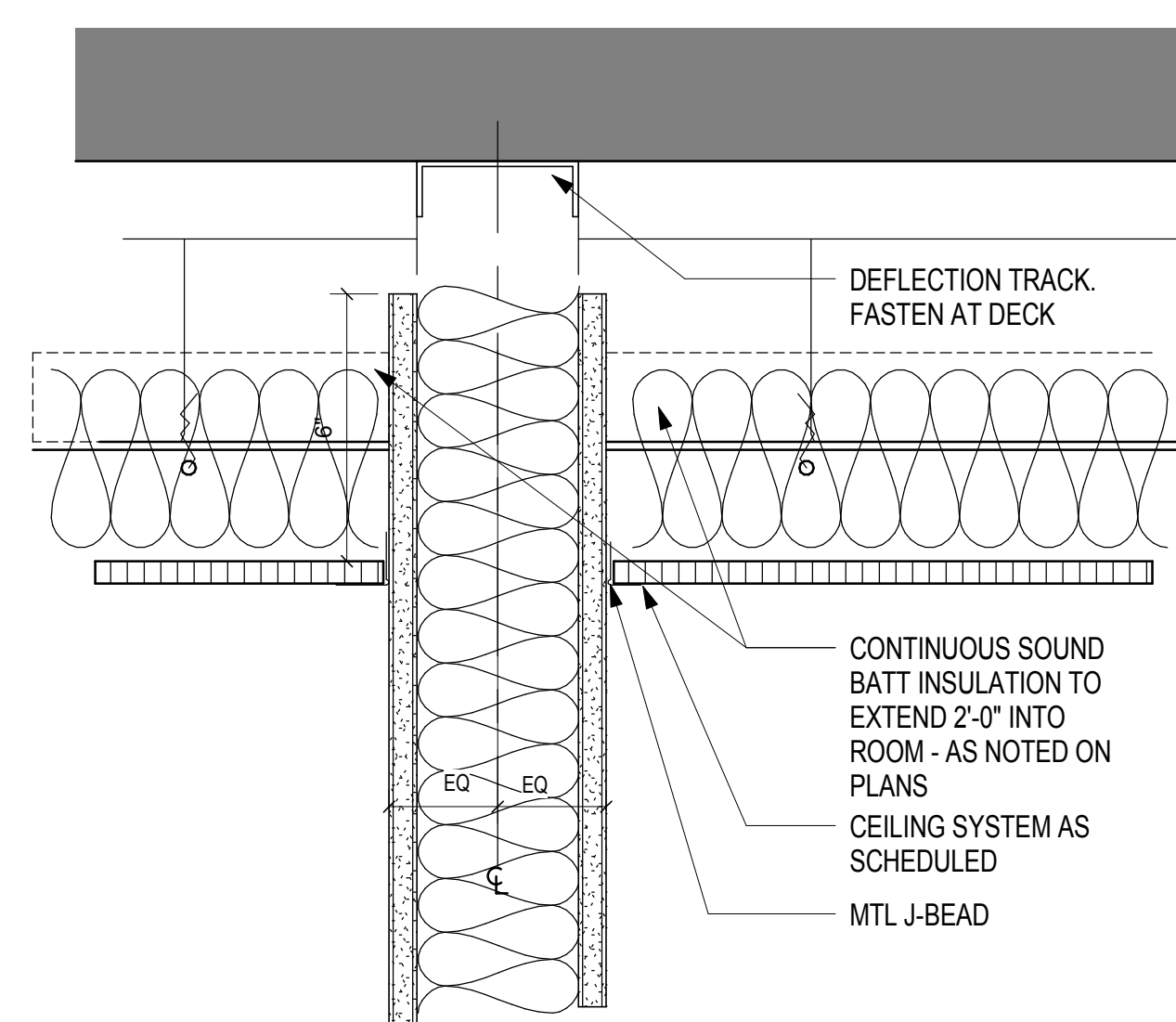

05 HEAD DETAIL - 'HA-01'
SCALE: 3" = 1'-0"

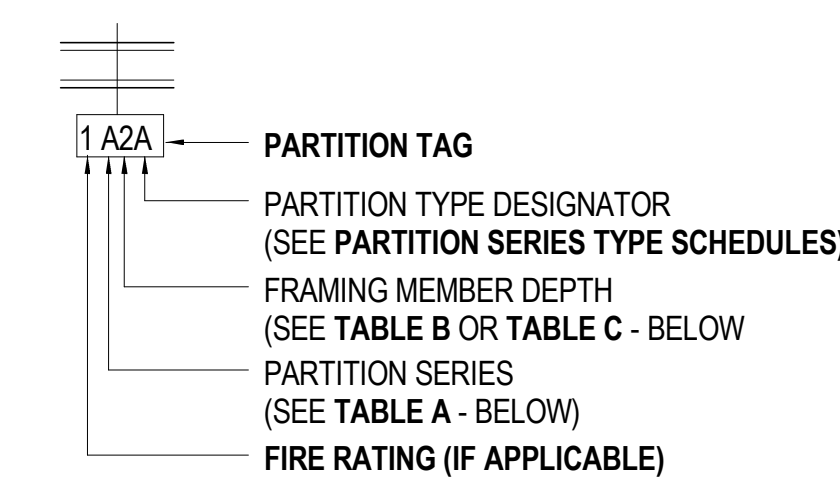

TABLE A - PARTITION SERIES CONSTRUCTION ASSEMBLY

SERIES	SHEATHING	FRAMING MEMBERS	SHEATHING
A	1-LAYER	METAL C-STUD	1-LAYER

TOP OF PARTITION DETAILS

TYPE	DESCRIPTION
HA-01	TOP OF PARTITION STUD AT UNDERSIDE OF CONCRETE SLAB AND SHEATHING 6" ABOVE SCHEDULED FINISHED CEILING
HA-02	TOP OF PARTITION AT UNDERSIDE OF CONCRETE SLAB (NON-RATED)
HA-03	TOP OF PARTITION AT UNDERSIDE OF SCHEDULED FINISHED CEILING

BOTTOM OF PARTITION DETAILS

TYPE	DESCRIPTION
B01	BOTTOM OF PARTITION AT SLAB

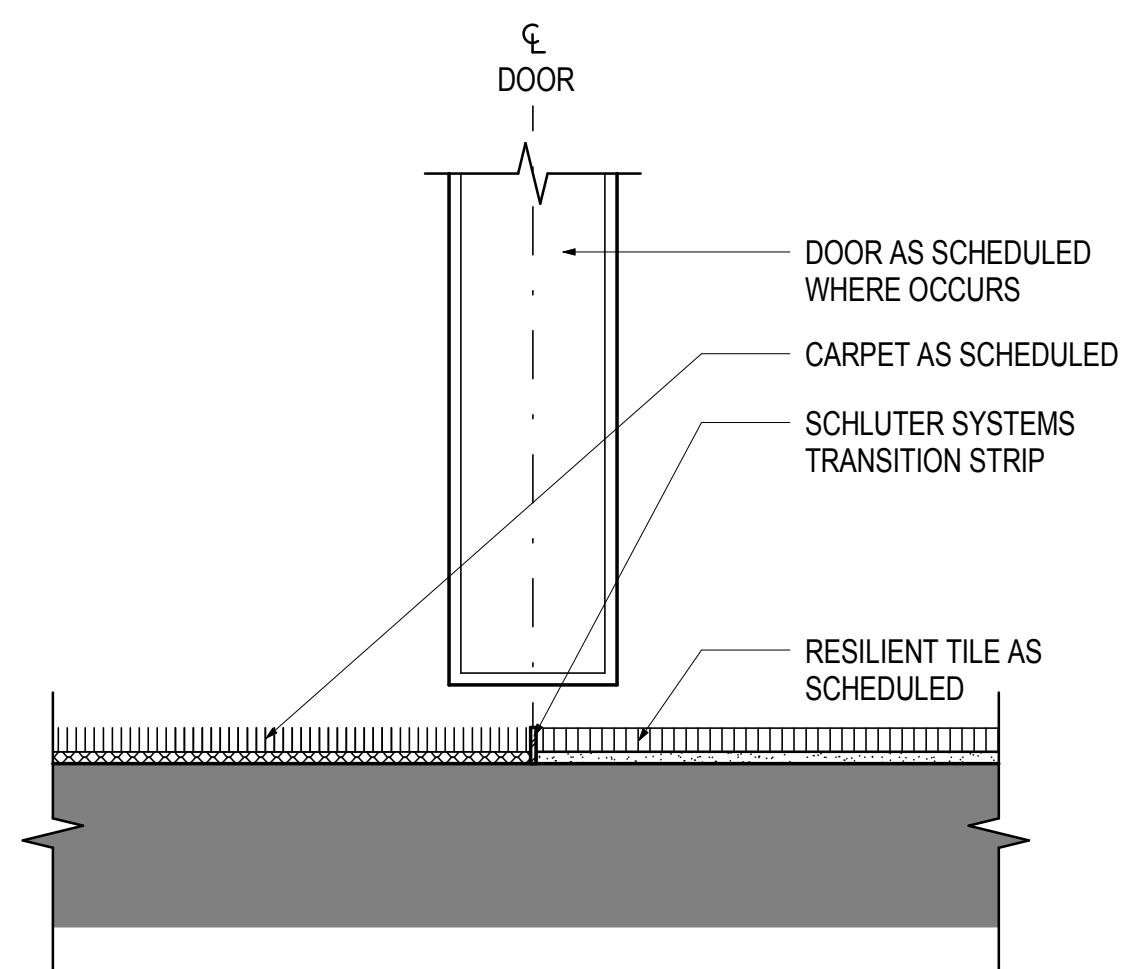

16 CARPET TO RESILIENT TILE
SCALE: 6" = 1'-0"

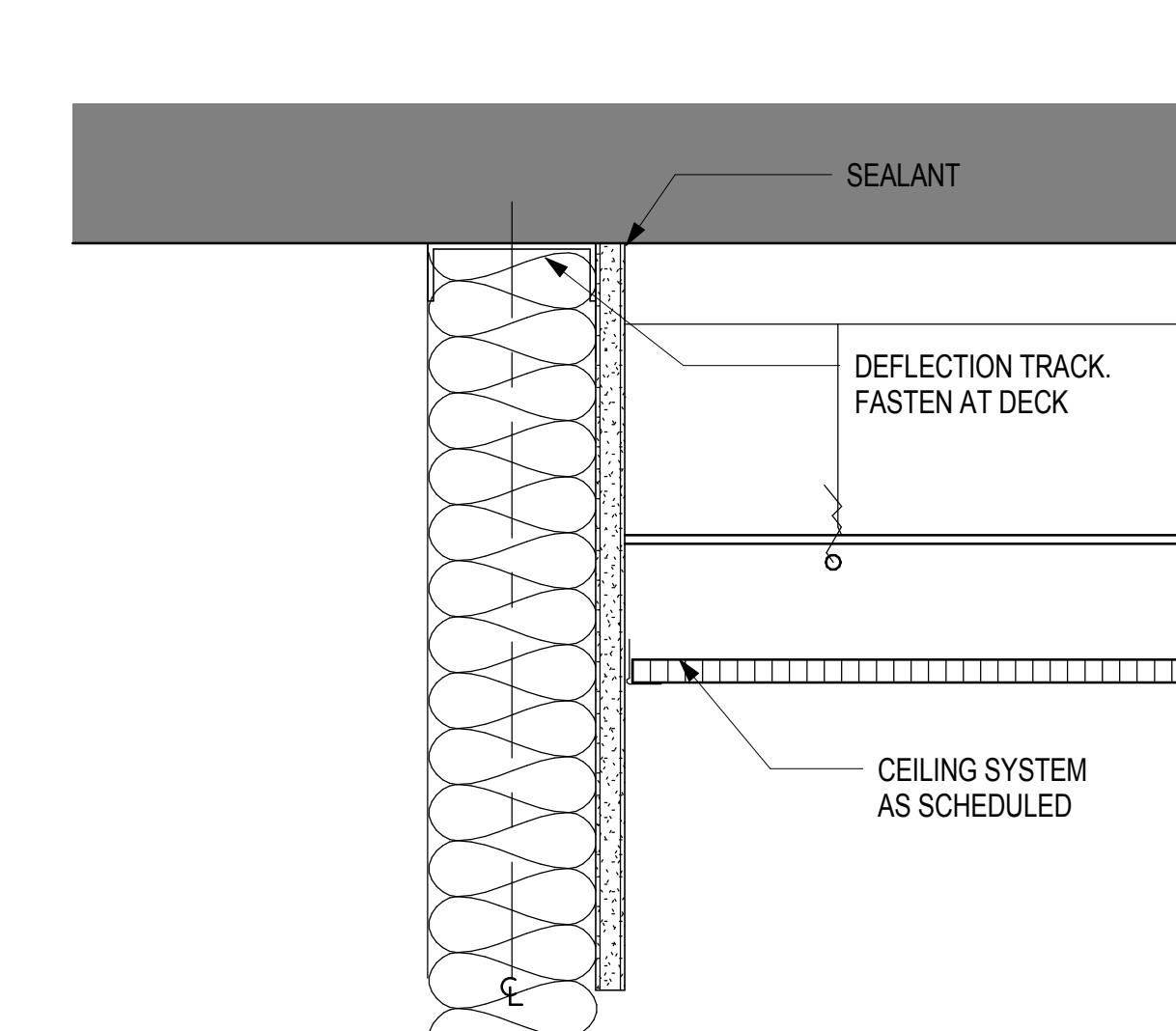

11 HEAD DETAIL - 'HD-02'
SCALE: 3" = 1'-0"

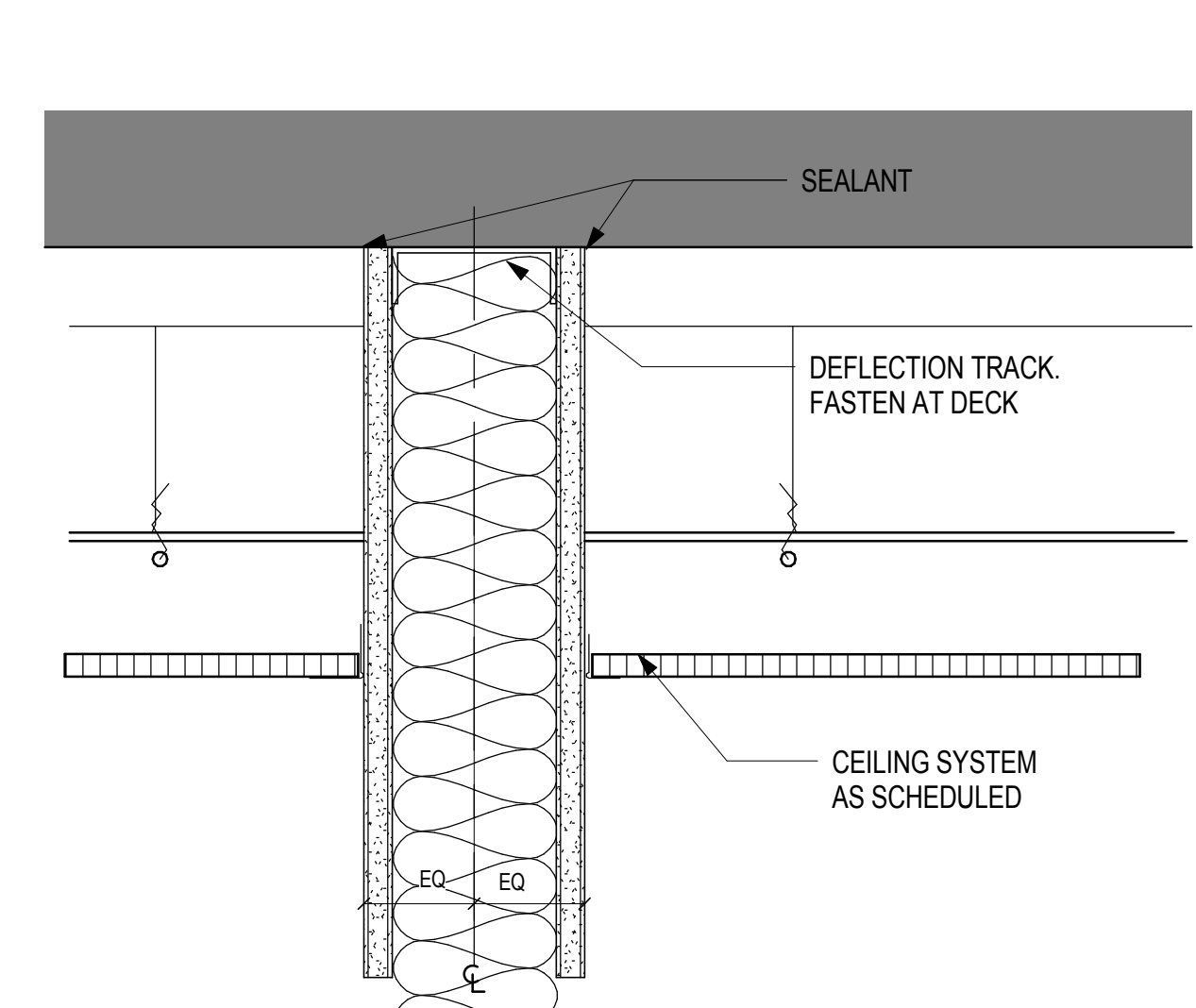

06 HEAD DETAIL - 'HA-02'
SCALE: 3" = 1'-0"

02 PARTITION KEY

SCALE: 3" = 1'-0"

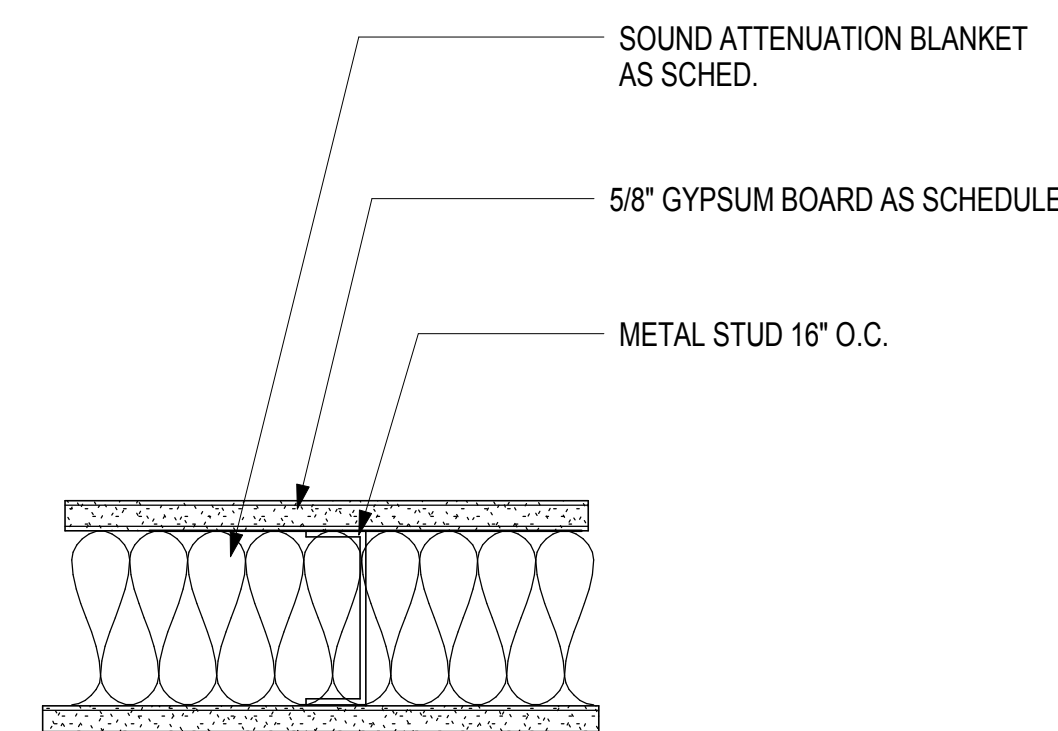

PARTITION TYPE MARK	FRAMING			DETAILS		ATTN THK	FIRE RTG	TESTED ASSEMBLY	STC RTG	SHEET NOTES
	THK (IN)	DEPTH	SPACING	TOP	BOT					
A2A	3 3/4"	2 1/2"	16"	HA-01	BA-01	2 1/2"				
A2B	3 3/4"	2 1/2"	16"	HA-02	BA-01	2 1/2"				
A3A	4 7/8"	3 5/8"	16"	HA-01	BA-01	3 5/8"				
A3B	4 7/8"	3 5/8"	16"	HA-02	BA-01	3 5/8"				
A3C	4 7/8"	3 5/8"	16"	HA-03	BA-01	3 5/8"				
A3D	4 7/8"	3 5/8"	16"	HA-04	BA-02	3 5/8"	1	U419		

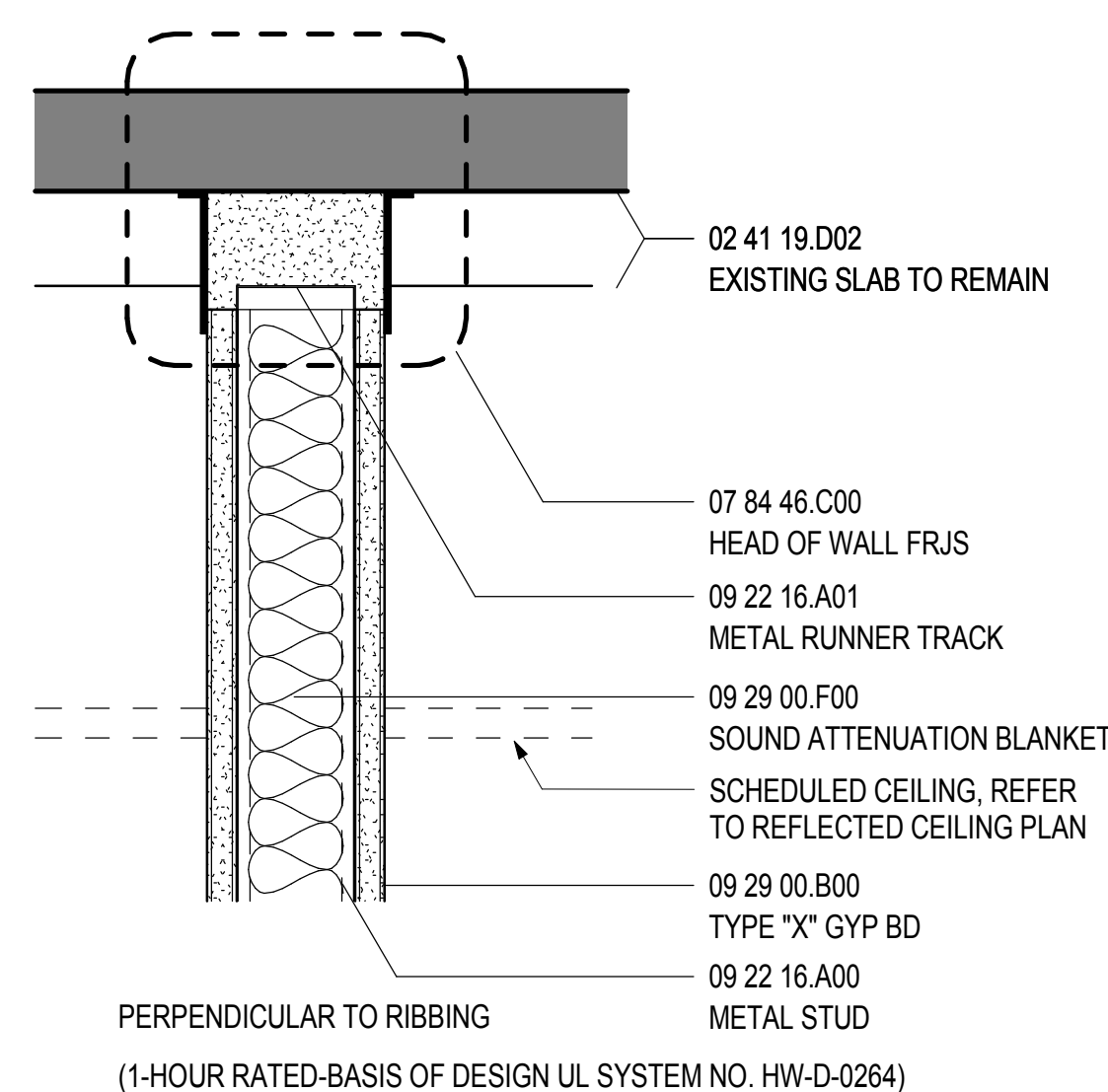

17 HEAD DETAIL 'HA-04'
SCALE: 3" = 1'-0"

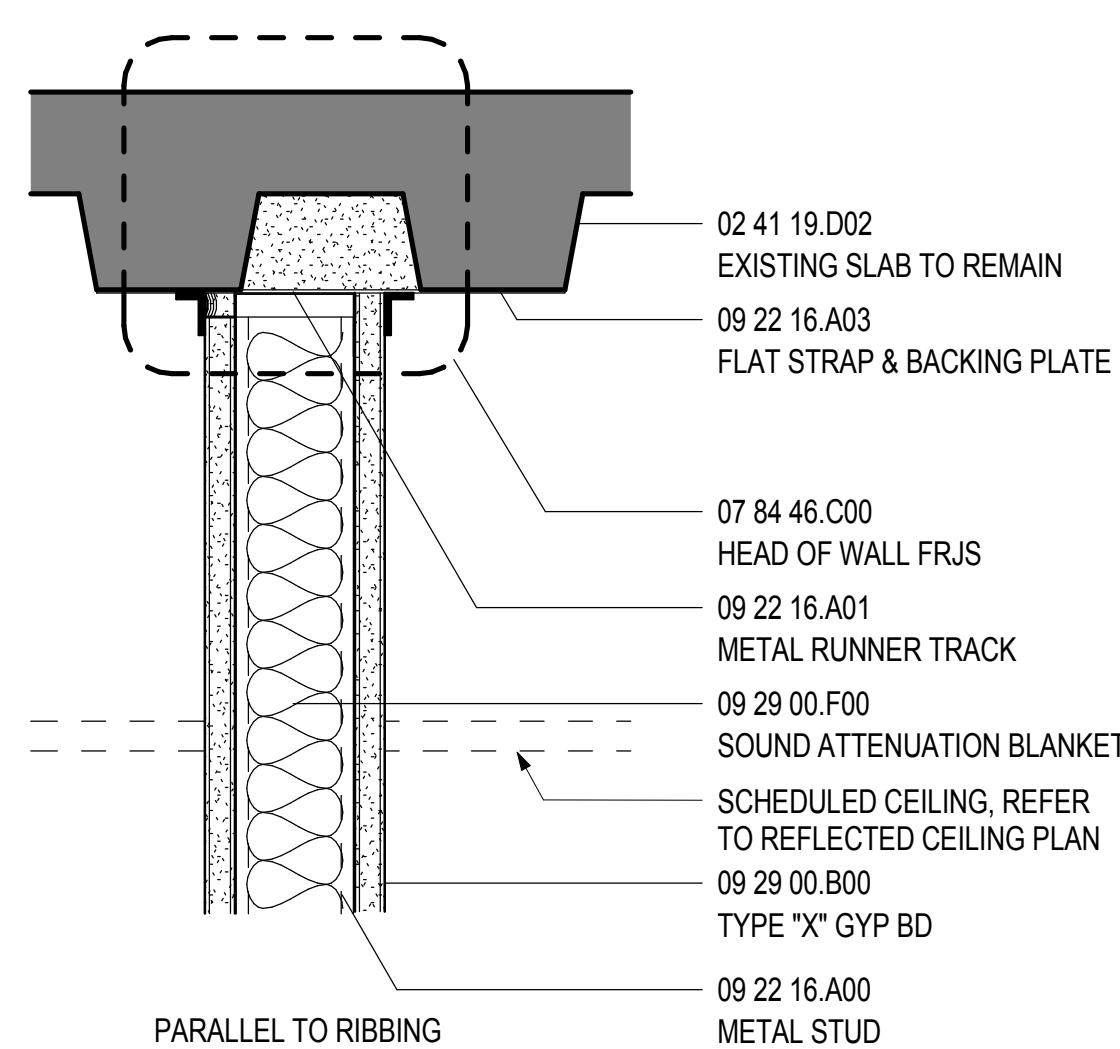

13 BASE DETAIL BA-02
SCALE: 3" = 1'-0"

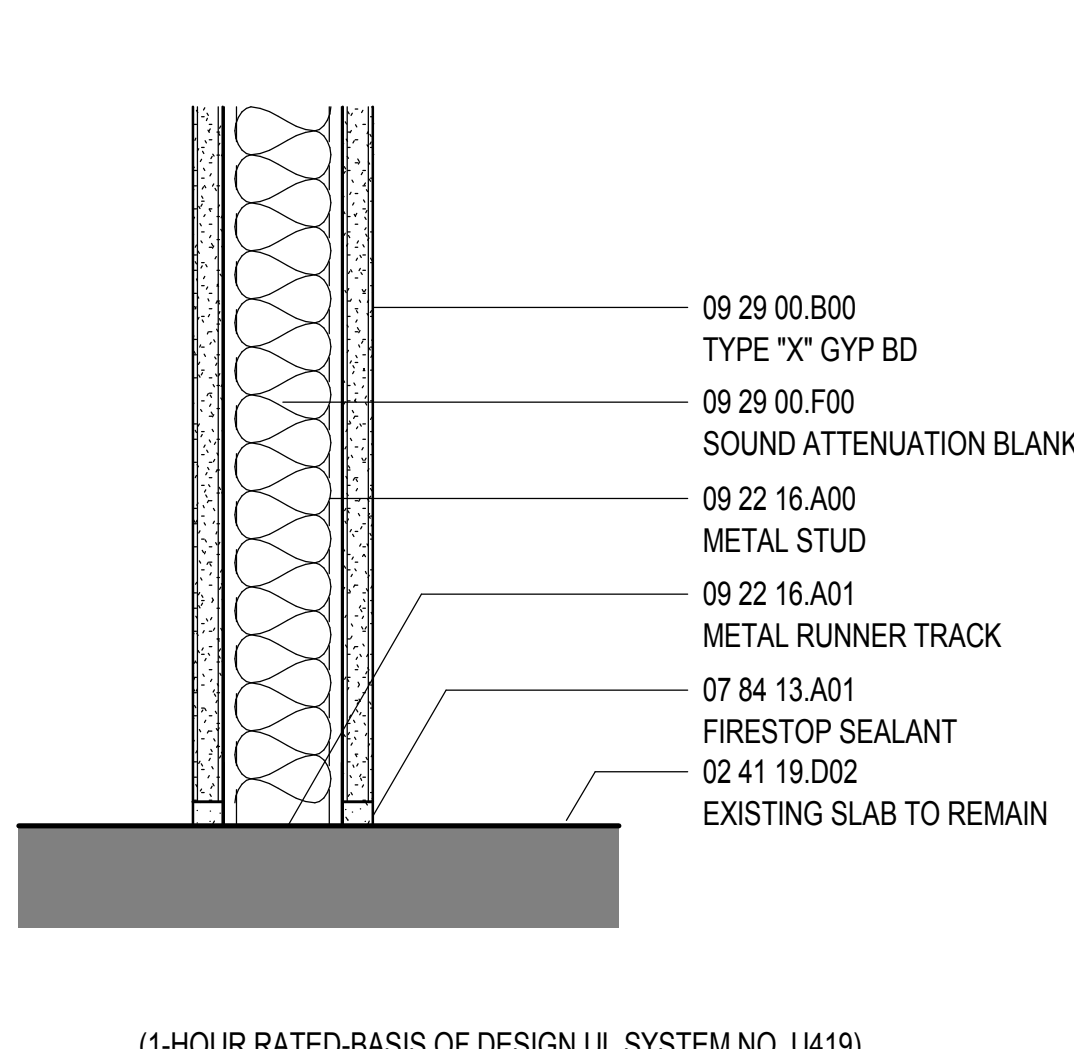

07 HEAD DETAIL - 'HA-03'
SCALE: 3" = 1'-0"

03 PARTITION TYPE - A
SCALE: 3" = 1'-0"

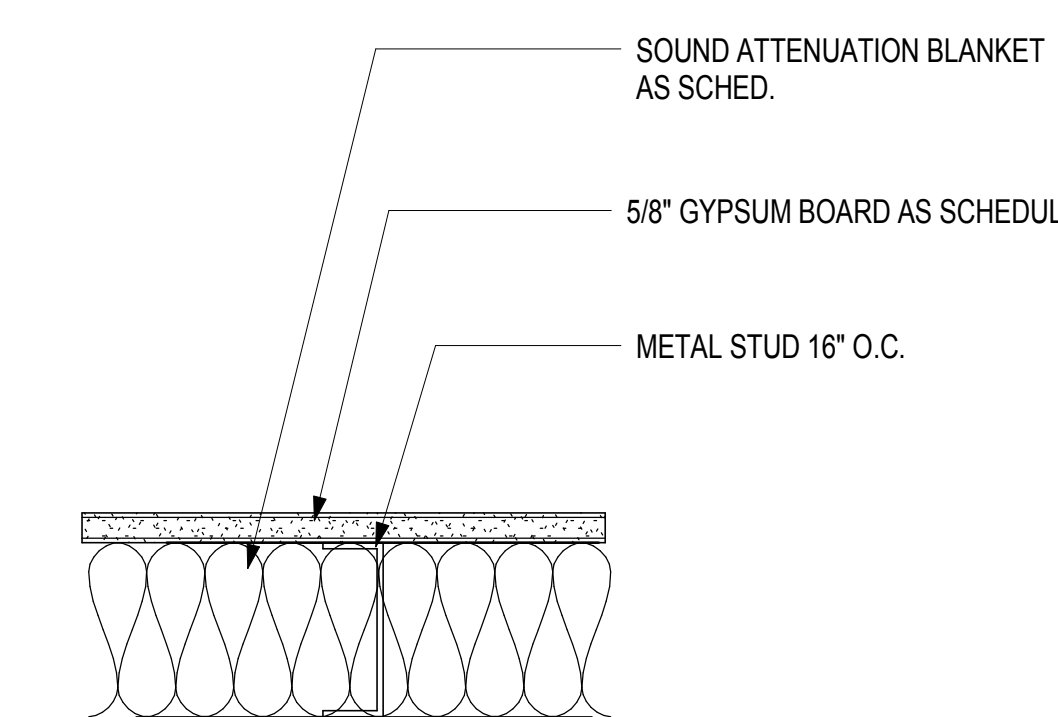

PARTITION TYPE MARK	FRAMING			DETAILS		ATTN THK	FIRE RTG	TESTED ASSEMBLY	STC RTG	SHEET NOTES
	THK (IN)	DEPTH	SPACING	TOP	BOT					
D3B	4 7/8"	3 5/8"	16"	HA-02	HD-01	3 5/8"				

04 PARTITION TYPE - D
SCALE: 3" = 1'-0"

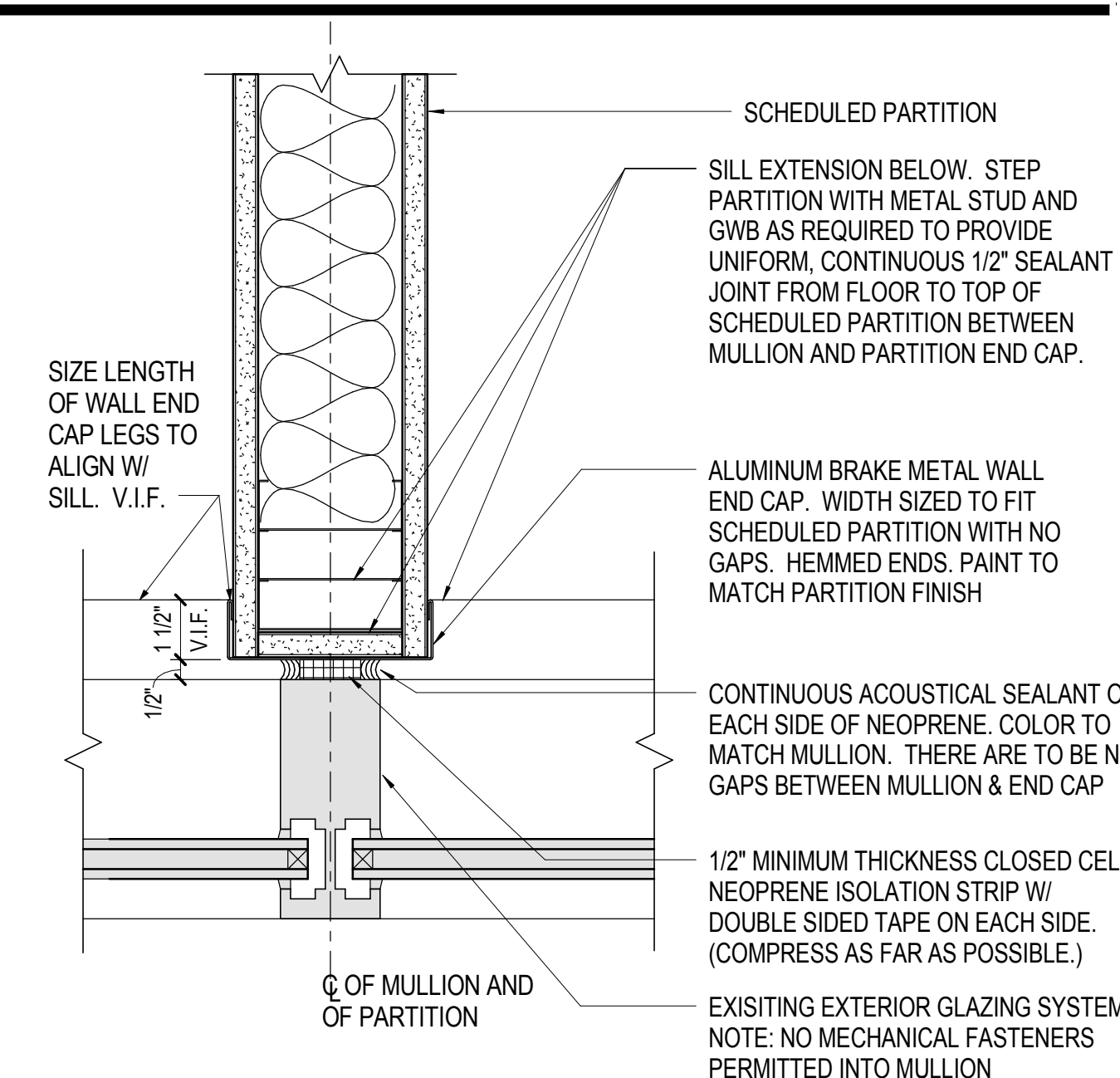

18 WALL AT MULLION
SCALE: 3" = 1'-0"

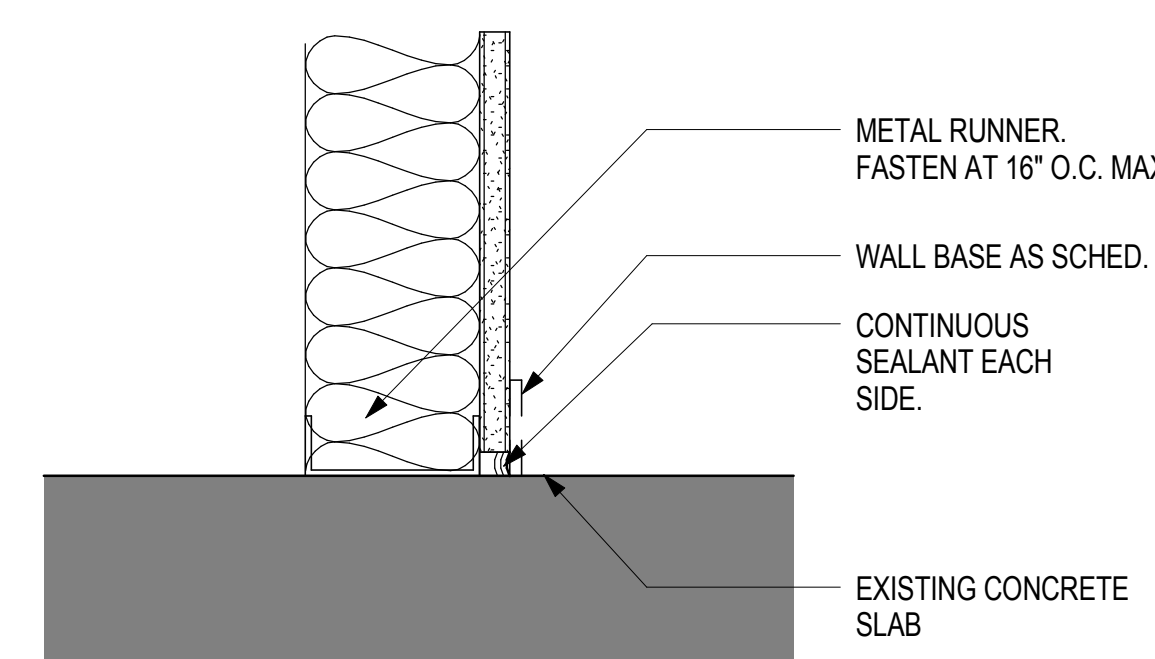

14 BASE DETAIL - 'BD-01'
SCALE: 3" = 1'-0"

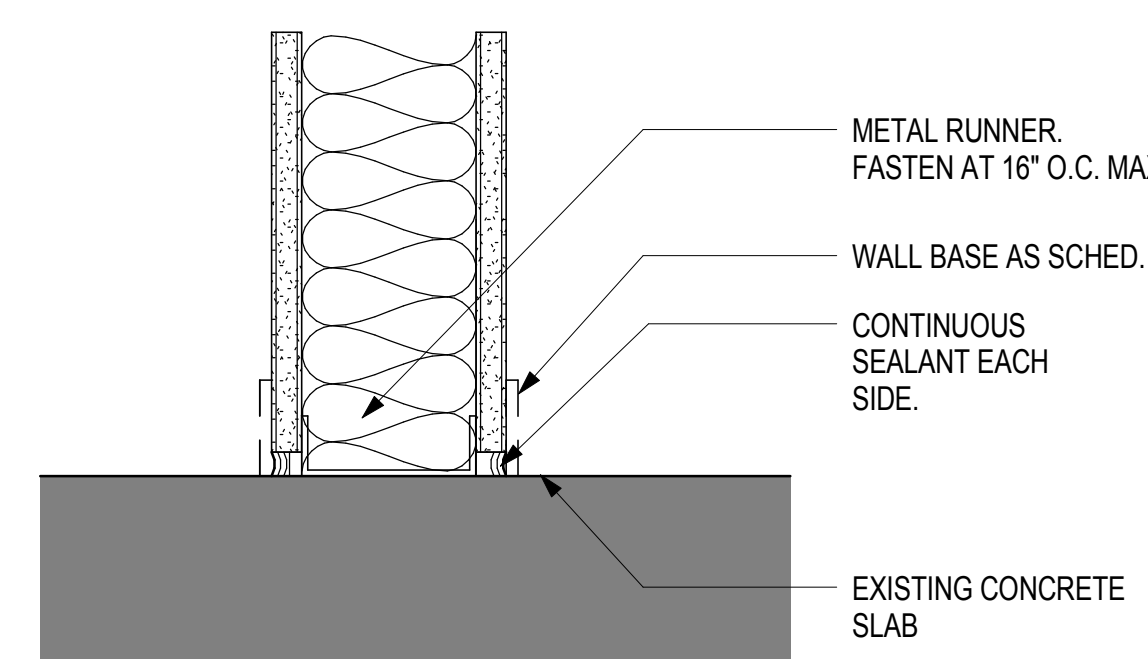

08 BASE DETAIL - 'BA-01'
SCALE: 3" = 1'-0"

Date: 08/08/14
Description: ISSUED FOR CONSTRUCTION

Seal / Signature

Project Name

URS - PORTLAND

Project Number

59 6222 900

Scale

As indicated

Description

WALL PARTITION TYPES & FLOOR TRANSITIONS

G00.20

© 2014 Gensler