

**RED THREAD**  
 ONE CITY CENTER, FIRST FLOOR  
 PORTLAND, MAINE

### INTERIOR FINISH LEGEND

060413  
RED THREAD

CODE	MATERIAL	MANUFACTURER	PRODUCT, STYLE AND COLOR	FINISH	REMARKS/NOTES
C1	CARPET	SHAW CONTRACT GROUP	SHAW DISOLVE TILE #9569-88504 ASHEN BRICK INSTALL	FACTORY	
C2	CARPET	SHAW CONTRACT GROUP	SHAW TRU COLORS 59368-68865 CLEAR RED	FACTORY	ACCENT CARPET AT SEATING DISPLAY ONLY
WOOD	WOOD FLOOR	OREGON LUMBER	BEAM: RIFTQUARTERED WHITE OAK WHITE WASH; SOLID ENGINEERING 3/4", 3.5"W, 2" TO 7" LENGTHS	FACTORY	
BASE	REVEAL BASE	FRY REGLET REVEAL BASE	#DRMB-625-250 PAINTED TO MATCH WALL	FACTORY	
P1	PAINT	BENJAMIN MOORE	SUPERWHITE	EGGSHELL	
P2	PAINT	PITTSBURGH PAINT	RED GUMBALL 233-7	SEMI-GLOSS	
P3	PAINT	BENJAMIN MOORE	IRON MOUNTAIN 2134-30	SEMI-GLOSS	
PL1	PLASTIC LAMINATE	FORMICA	FORMICA COLOR CORE 2 #7223C-00 NEW WHITE	GLOSS	
T1	TILE	COT BRIQUETTE	IGLOO STONE MOSAIC	FACTORY	
G1	GROUT	MAPEI	COLOR: TBS	SEALED	
SS1	SOLID SURFACE	CAESARSTONE	COLOR: 2141 BLIZZARD QUARTZ	FACTORY	
SDT1	STATIC DISSIPATIVE TILE	ARMSTRONG	12"x12" TILE 51953 PEARL WHITE	SEALED	
SHADES	WINDOW SHADES	MECHOSHADE	SUN PROJECT: MODULINE ROLLER SHADE SYSTEM, #SC-2006 FABRIC (3% OPEN), MATERIAL PROVIDED BY OWNER	FACTORY	PROVIDE ALL MOUNTING HARDWARE

### INTERIOR FINISH SCHEDULE

060413  
RED THREAD

Room Information	Floor	Walls	Trim	Countertop/ Worksurface/ Cabinets	Remarks									
Room #	Room Name	Floor	Grout	North Wall	East Wall	South Wall	West Wall	Base	Decorative Trim(s)	Door(s)	Door & Window Moulding	Horizontal Plane	Vertical Plane	Remarks
<b>Basement Floor Plan</b>														
100	RECEPTION	WOOD	NA	P2,P3	P1	P1	P1	WD-PTD.	P1	-	-	SS1	PL1	COFFEE COUNTER FINISHES REFER TO INTERIOR ELEVATION G1A900. RAMP TO HAVE C1 FOR FLOOR FINISH
101	CUSTOMER AREA	WOOD	NA	P1	P1	P1	P1	WD-PTD.	P1	-	-	NA	NA	ALL EXISTING COLUMNS TO RECEIVE NEW PAINT P1 AND FRY REGLET BASE PTD. P1
102	STAFF TOUCH-DOWN	WOOD	NA	-	-	-	-	WD-PTD.	P1	-	-	NA	NA	
103	OFFICE 1	C1	NA	-	-	-	-	-	-	-	-	NA	NA	ROOM IS CREATED BY SYSTEM FURNITURE WALLS
104	OFFICE 2	C1	NA	-	-	-	-	-	-	-	-	NA	NA	ROOM IS CREATED BY SYSTEM FURNITURE WALLS
105	MEETING SPACE 1	C1	NA	-	-	-	-	-	-	-	-	NA	NA	ROOM IS CREATED BY SYSTEM FURNITURE WALLS
106	MEETING SPACE 2	C1	NA	-	-	-	-	BASE	P1	-	-	NA	NA	ROOM IS CREATED BY SYSTEM FURNITURE WALLS
106A	KITCHENETTE	C1	G1	P1/T1	P1	-	P1	BASE	P1	-	-	SS1	PL1	KITCHENETTE FINISHES REFER TO INTERIOR ELEVATION A1A900. G1 WITH T1 WALL TILE
107	WORK AREA	C1	NA	-	-	-	-	-	-	-	-	NA	NA	PAINT COLUMN P1
108	COPY/PRINT	C1	NA	P1	P1	-	-	BASE	P1	-	-	NA	NA	
109	MEETING SPACE 3	C1	NA	P1	-	-	P1	BASE	P1	-	-	NA	NA	
110	DESIGN LIBRARY	C1	NA	P1	-	-	P1	BASE	P1	-	-	NA	NA	
111	COATS/STORAGE	C1	NA	P1	P1	P1	P1	BASE	P1	-	-	NA	NA	RAMP TO HAVE C1 FOR FLOOR FINISH
112	SEATING/DISPLAY	C1/C2	NA	P1	P1	P2,P3	P1	BASE	P1	-	-	NA	NA	C2 CARPET ACCENT 4'-6"x13'-3" OUT FROM WALL. REFER TO INTERIOR ELEVATION FOR PAINT DESIGNATION
113	TEL/DATA	SDT1	NA	P1	P1	P1	P1	BASE	P1	-	-	NA	NA	

## HI INTERIOR FINISH SCHEDULE & LEGEND

### DOOR SCHEDULE

DOORS										FRAMES				THRESHOLD		NO	
NO	TYPE	SIZE	THK.	HWDR SET	FINISH	MAT.	REMARKS	TYPE	MAT.	DETAILS/A800 HEAD	JAMB	REMARKS	RATING	MAT.	DETAILS/A800 SILL	HEIGHT	NO
100		ETR					INSTALL NEW LOCK SET FOR EXISTING DOORS										100
101		NOT USED															101
102		NOT USED															102
103		NOT USED															103
104		NOT USED															104
105		NOT USED															105
106		NOT USED															106
107		NOT USED															107
108		NOT USED															108
109		NOT USED															109
110		NOT USED															110
111	A	3'-0"x6'-8"	1 3/4"		FACTORY	WD	LOCK, PANIC HARDWARE	1	HM	H1	J1						111
112		NOT USED															112
113	A	3'-0"x6'-8"	1 3/4"		FACTORY	WD	LOCK	1	HM	H1	J1						113

1. ALL HARDWARE TO BE US28D FINISH - W/ LEVER TYPE HANDLE  
 2. PROVIDE BLOCKING FOR ALL HARDWARE  
 3. PAINT ALL INTERIOR HOLLOW METAL FRAMES P1  
 4. COORDINATE HARDWARE WITH TENANT

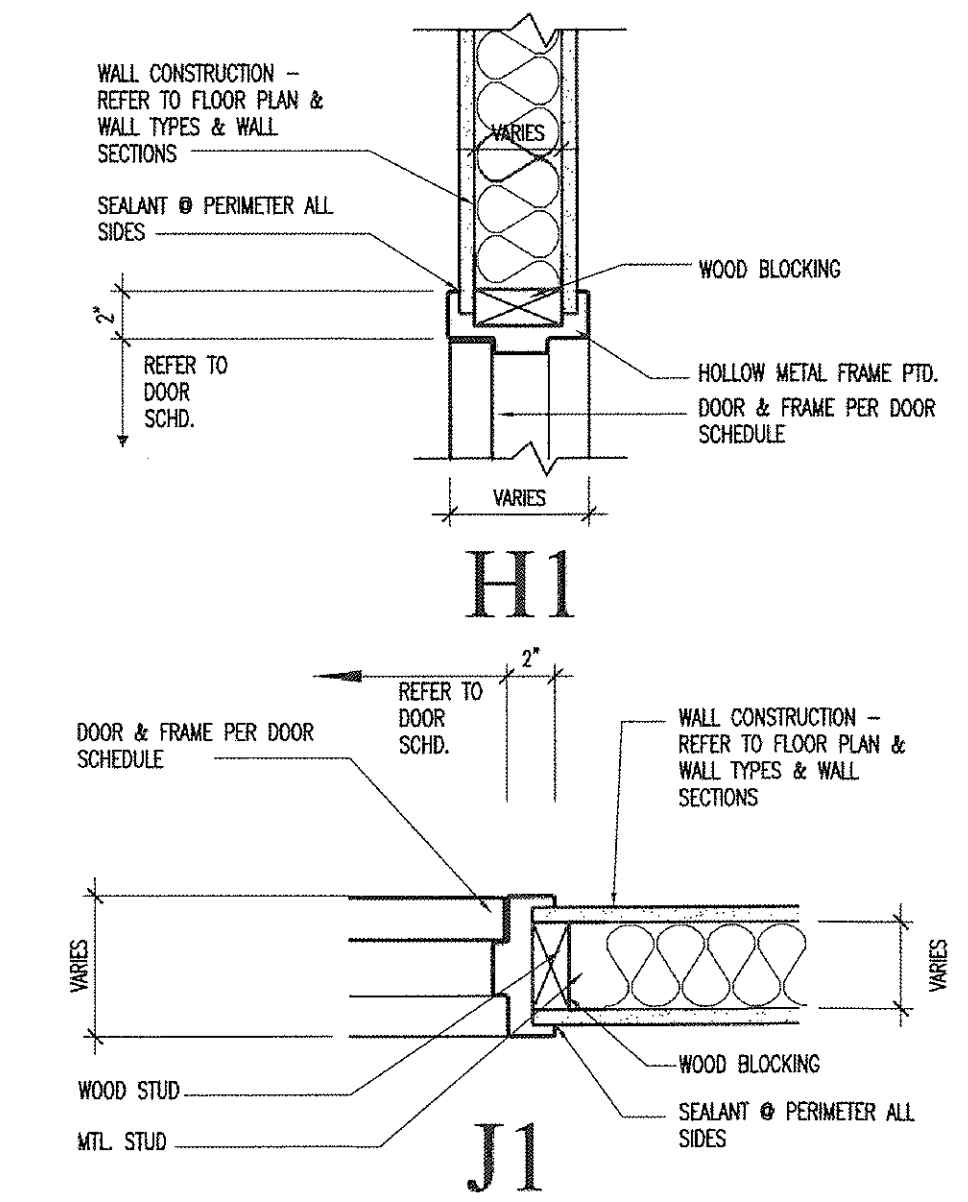
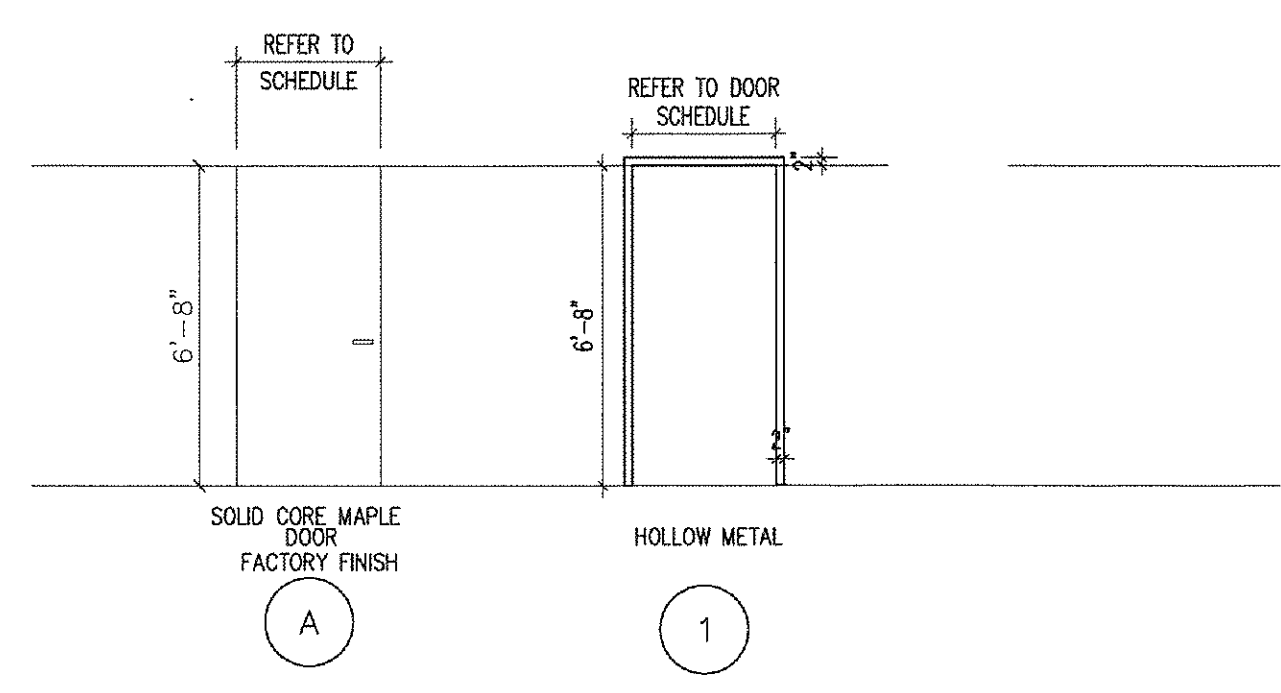

## AI DOOR SCHEDULE

## A10 DOOR & FRAME TYPE

## A15 HEAD & JAMB DETAIL

### REVISIONS

#	DATE	DESCRIPTION

DATE:	08.28.13
PROJECT #:	060413
DRAWN BY:	DLP
CHECKED BY:	SWG
DRAWING SCALE:	AS NOTED

SHEET TITLE  
 INTERIOR FINISH LEGEND & SCHEDULE  
 DOOR AND FRAME TYPES  
 DOOR SCHEDULE

# A800