

I:\gensler.ad\Projects\Rev\UserModelist196832016_BCA_City Center Portland ME_2014_19683.rvt

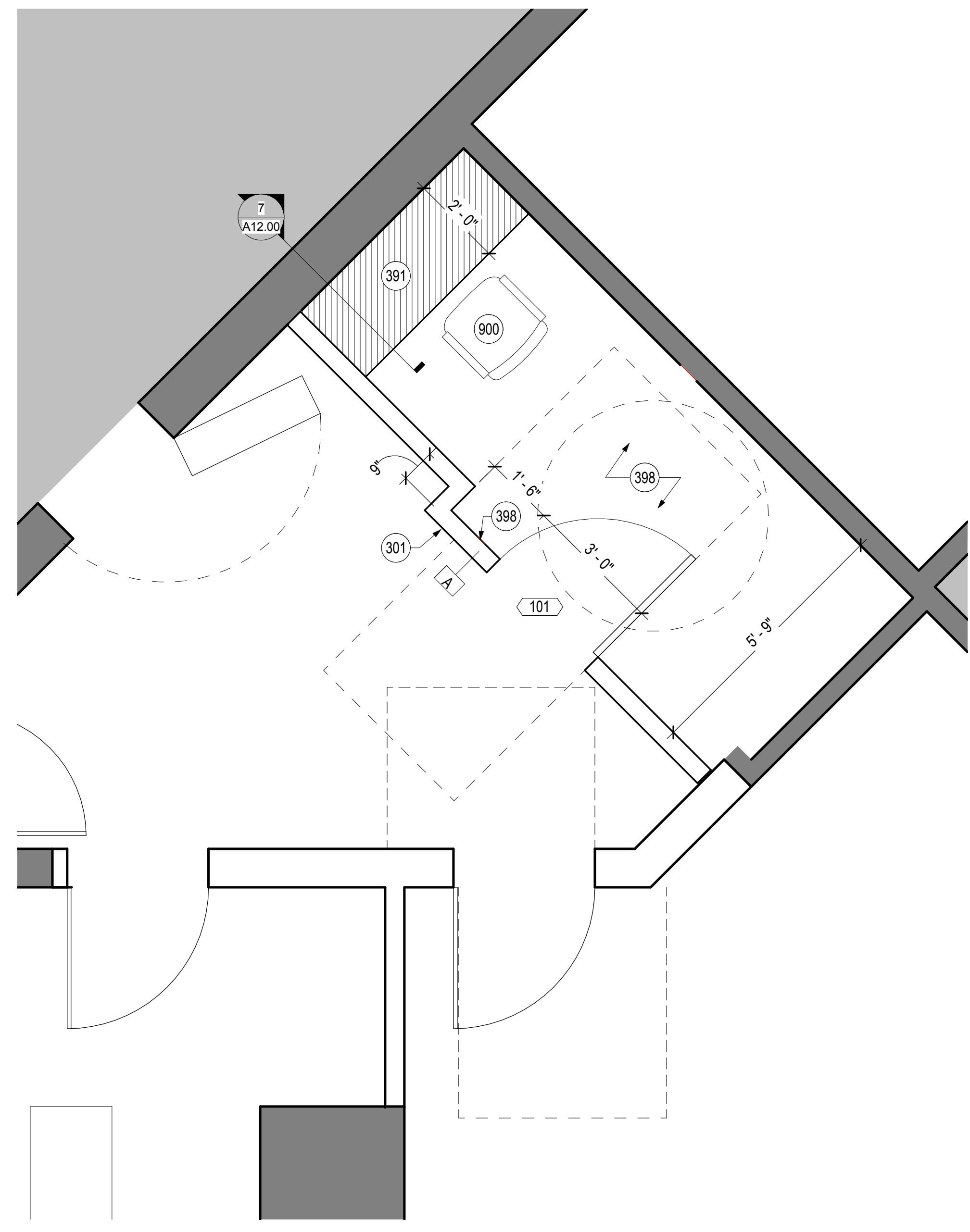

ENLARGED VIEWING AREA
SCALE: 1/2" = 1'-0"

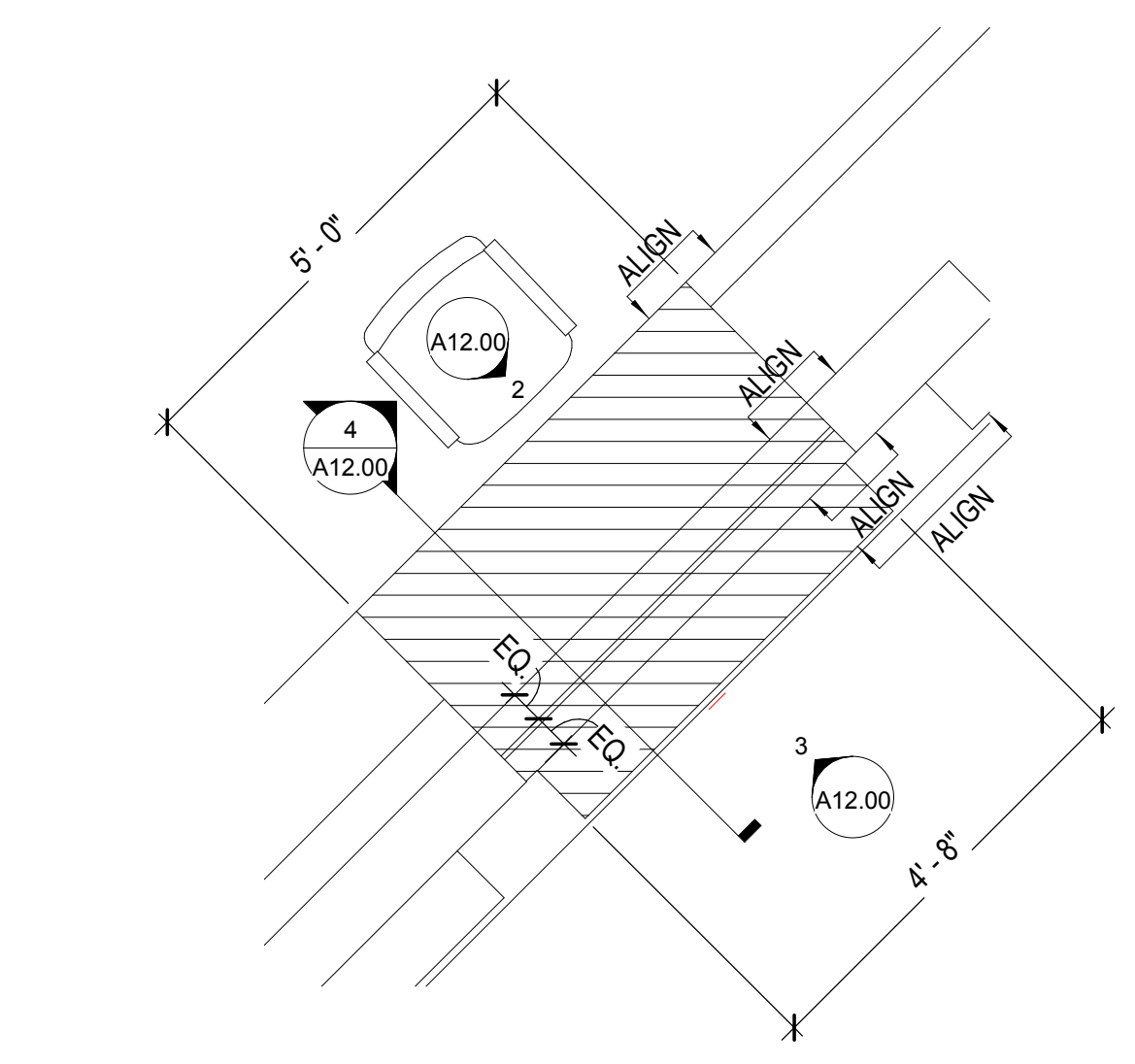

CONSTRUCTION PLAN
SCALE: 1/2" = 1'-0"

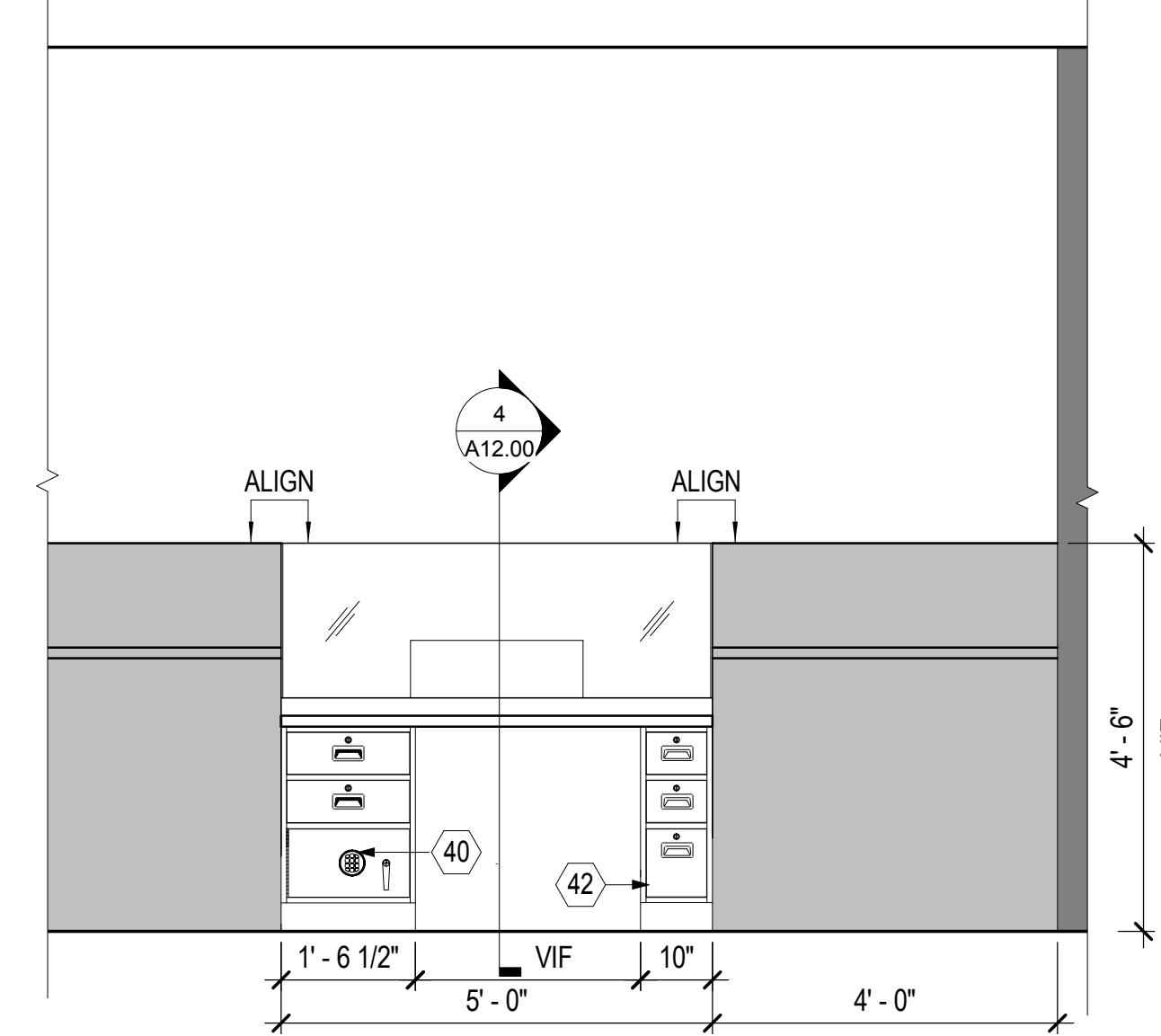

TELLER STATION ELEVATION - TELLER SIDE
SCALE: 1/2" = 1'-0"

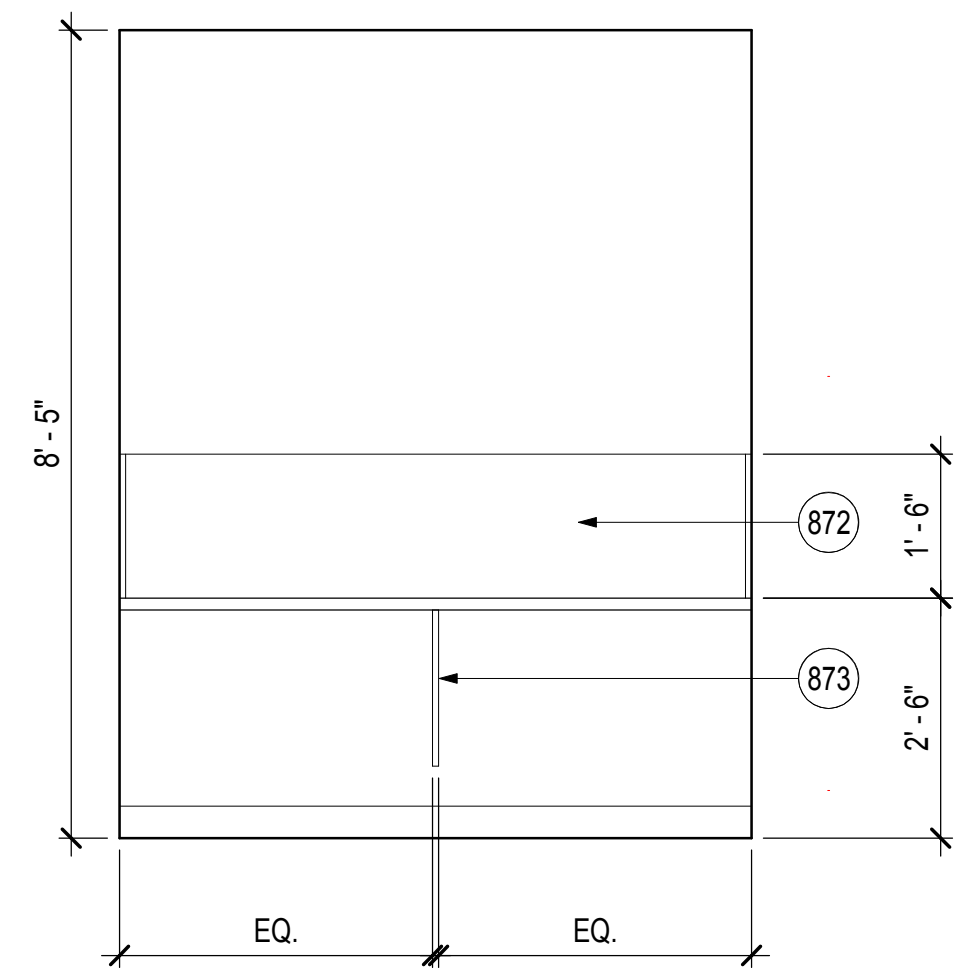

COUPON BOOTH ELEVATION
SCALE: 1/2" = 1'-0"

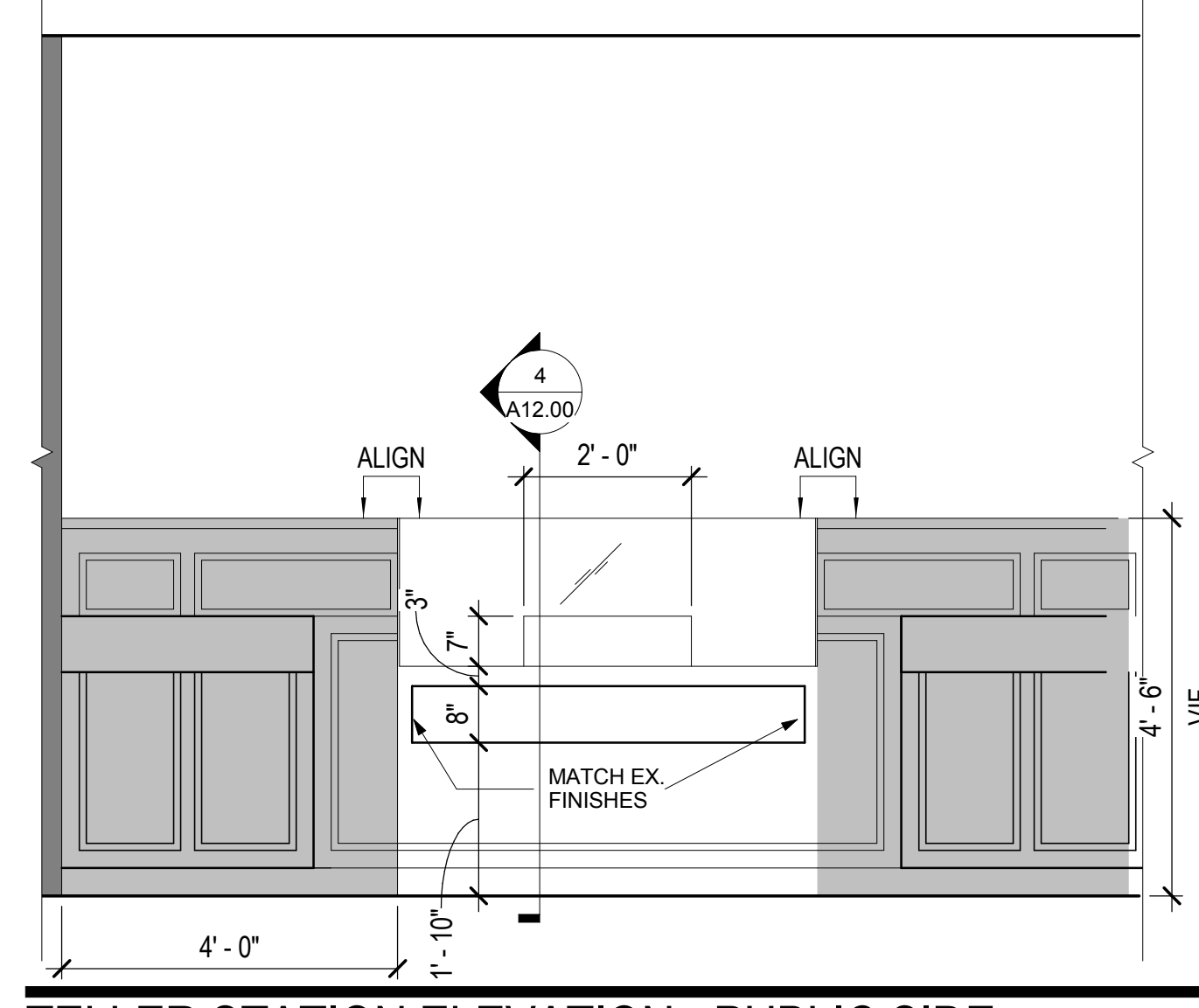

TELLER STATION ELEVATION - PUBLIC SIDE
SCALE: 1/2" = 1'-0"

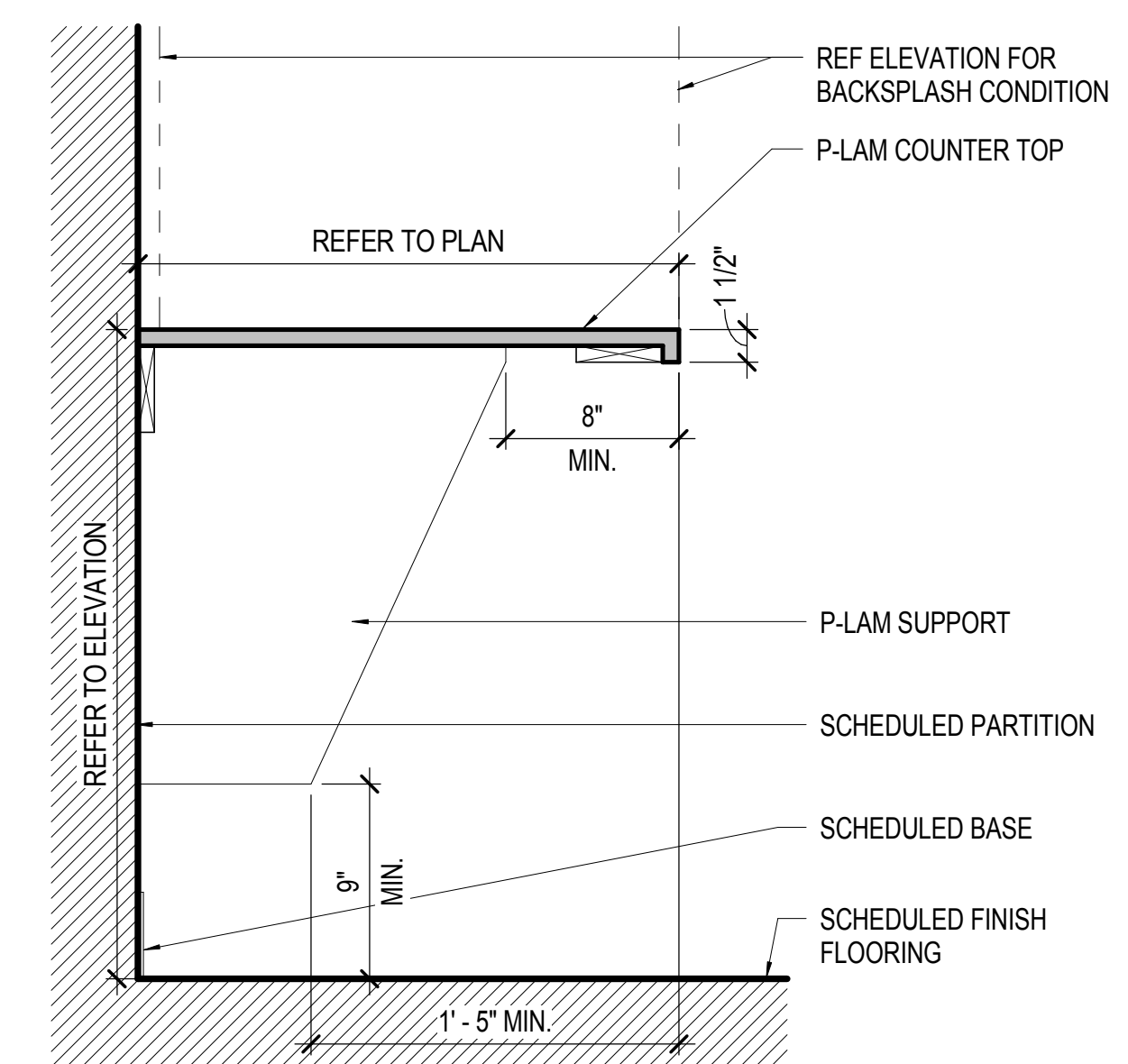

ADA COUNTER SECTION
SCALE: 1 1/2" = 1'-0"

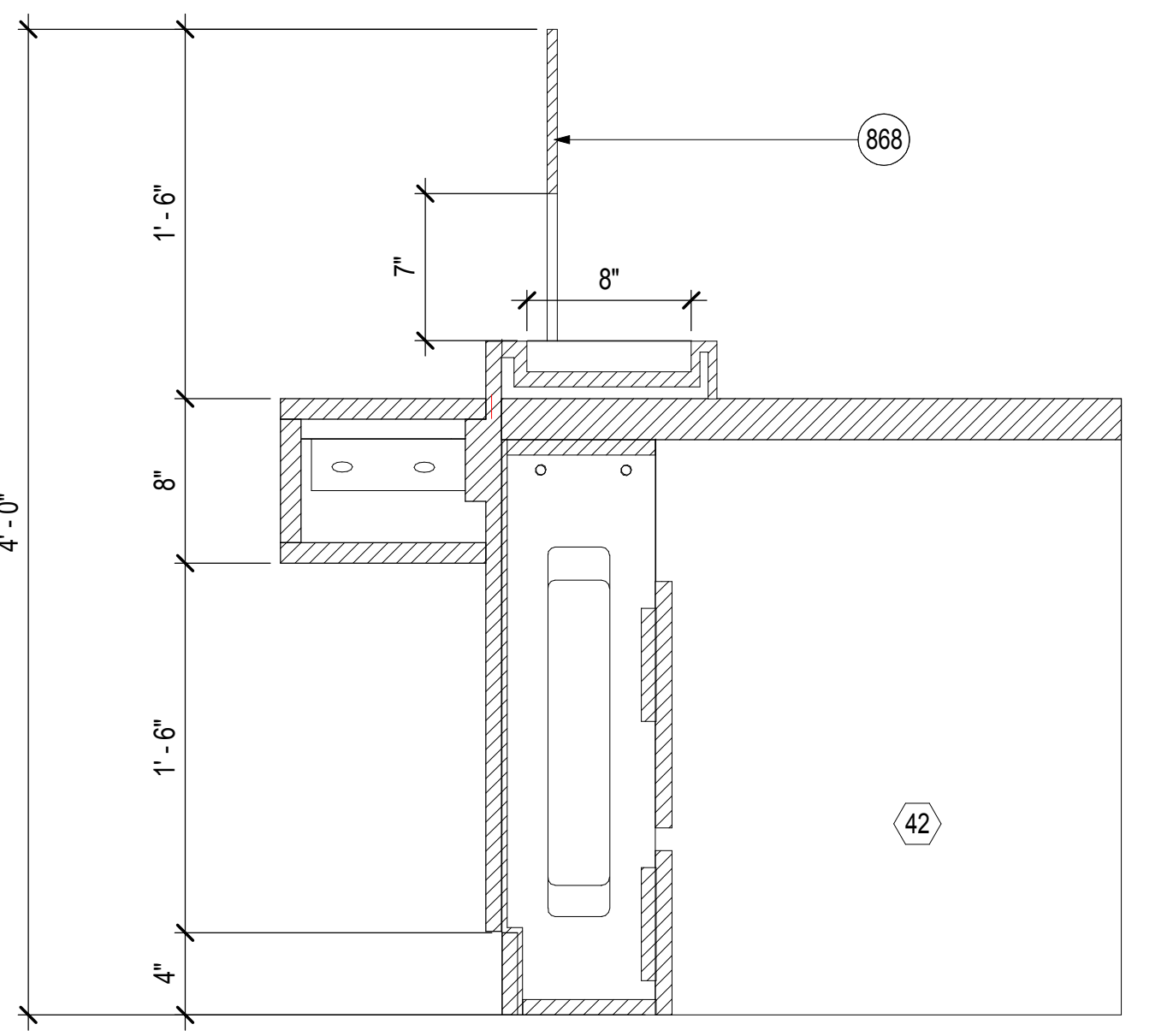

ADA TELLER SECTION
SCALE: 1 1/2" = 1'-0"

KEY NOTES

- 301 ALL NEW PARTITION WALL TYPES AND PATCHED WALLS TO BE FINISHED TO MATCH EXISTING. U.O.N. IF EXISTING. PROVIDE MATCHING WALL BASE. NEW CONSTRUCTION TO ALIGN AND MATCH EXISTING CONSTRUCTION WHERE INDICATED.
- 391 NEW COUPON BOOTH COUNTER.
- 398 PROVIDE NEW CPT-1 FLOOR FINISH.
- 868 1/2" CLEAR ACRYLIC WITH POLISHED EDGES. INSTALL ACRYLIC SCREEN WITH 2 SATIN ALUM. CHANNELS (LEFT AND RIGHT). RECESS INTO EXISTING MILLWORK AND SET ACRYLIC INTO CHANNEL WITH CLEAR SILICONE.
- 872 COUNTERTOP, BACKSLASH AND SIDE SPLASH BOTH SIDES TO BE PL-8 FINISH.
- 873 COUNTERTOP SUPPORT TO BE PL-7 FINISH.
- 900 PROVIDE NEW CH-3 STEELCASE MOVE CHAIR.

GENERAL NOTES

- A. ALL INTERIOR OF MILLWORK TO BE WHITE MELAMINE, UNLESS NOTED OTHERWISE.
- B. ALL EXPOSED SURFACES OF MILLWORK TO BE PLASTIC LAMINATE AS SPECIFIED ON ELEVATIONS.
- C. REF. SHEET A00.40 FOR TYPICAL WALL MOUNTING HEIGHTS.
- D. CONTRACTOR TO COORDINATE ALL POWER AND COMMUNICATIONS AT TELLER COUNTER.
- E. CONTRACTOR SHALL PROVIDE BLOCKING PER ALL EQUIPMENT/ACCESSORIES MOUNTED ON WALL.
- F. ALL DEVICE COVER PLATES INCLUDING PLATES FOR COAX SHALL MATCH LUTRON LIGHT ALMOND UNLESS NOTED OTHERWISE.
- G. G.C. TO PROVIDE CAULK AROUND ALL UNDERCOUNTER STEEL AS REQUIRED. COLOR TO MATCH UNDERCOUNTER STEEL AS PROVIDED.
- H. G.C. SHALL PROVIDE ALL WORK RELATED TO ENGINEERING TO INCLUDE, BUT NOT LIMITED TO: MECHANICAL, ELECTRICAL, FIRE PROTECTION & LIFE SAFETY. G.C. SHALL PROVIDE DESIGN DRAWINGS, PERMITS & INSTALLATION OF SYSTEMS ON A DESIGN BUILD BASIS.
- I. FOR FINISH SCHEDULE, REFER A00.20
- J. WHEN A GAP EXISTS BETWEEN THE TOP OF THE UNDERCOUNTER STEEL AND THE UNDERSIDE OF THE COUNTER, G.C. TO BUILD A 1" MILLWORK BASE TO MATCH EXISTING FINISH AND CONSTRUCTION.
- K. ALL SECURITY DEVICES AND SYSTEMS TO REMAIN INTACT DURING ALL PHASES OF WORK. ANY MODIFICATIONS NEEDED DUE TO AREA OF DEMOLITION AND NEW CONSTRUCTION LAYOUT TO BE PERFORMED BY OWNER'S SECURITY VENDOR AND TO BE COORDINATED WITH OWNER PRIOR TO DEMOLITION.

Issue #	Issue Date	Issue Description
1	04/25/2016	ISSUED FOR 100% CDs

Seal/Signature _____

Project Name
ADA UPGRADES

Project Number
11.6560.202

Description
SECTIONS, ELEVATIONS, & TYPICAL DETAILS

Scale
As indicated

A12.00

© 2015 Gensler

NOTE: EVERY KEY NOTE MAY NOT APPEAR ON THIS PAGE