

1 BASE CABINET WITH ACCESSIBLE SINK
1 1/2" = 1'-0"

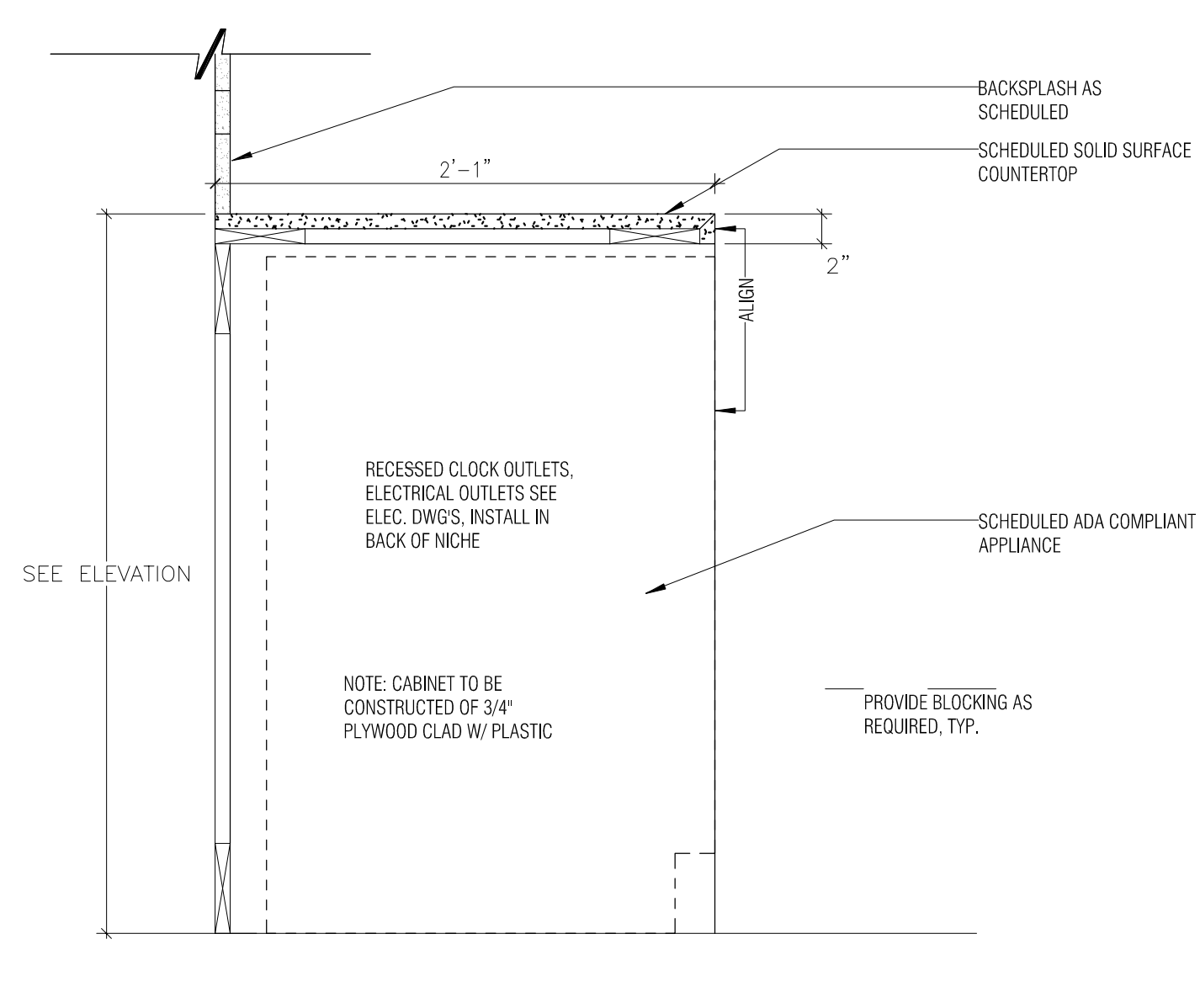

2 BASE CABINET WITH APPLIANCE
1 1/2" = 1'-0"

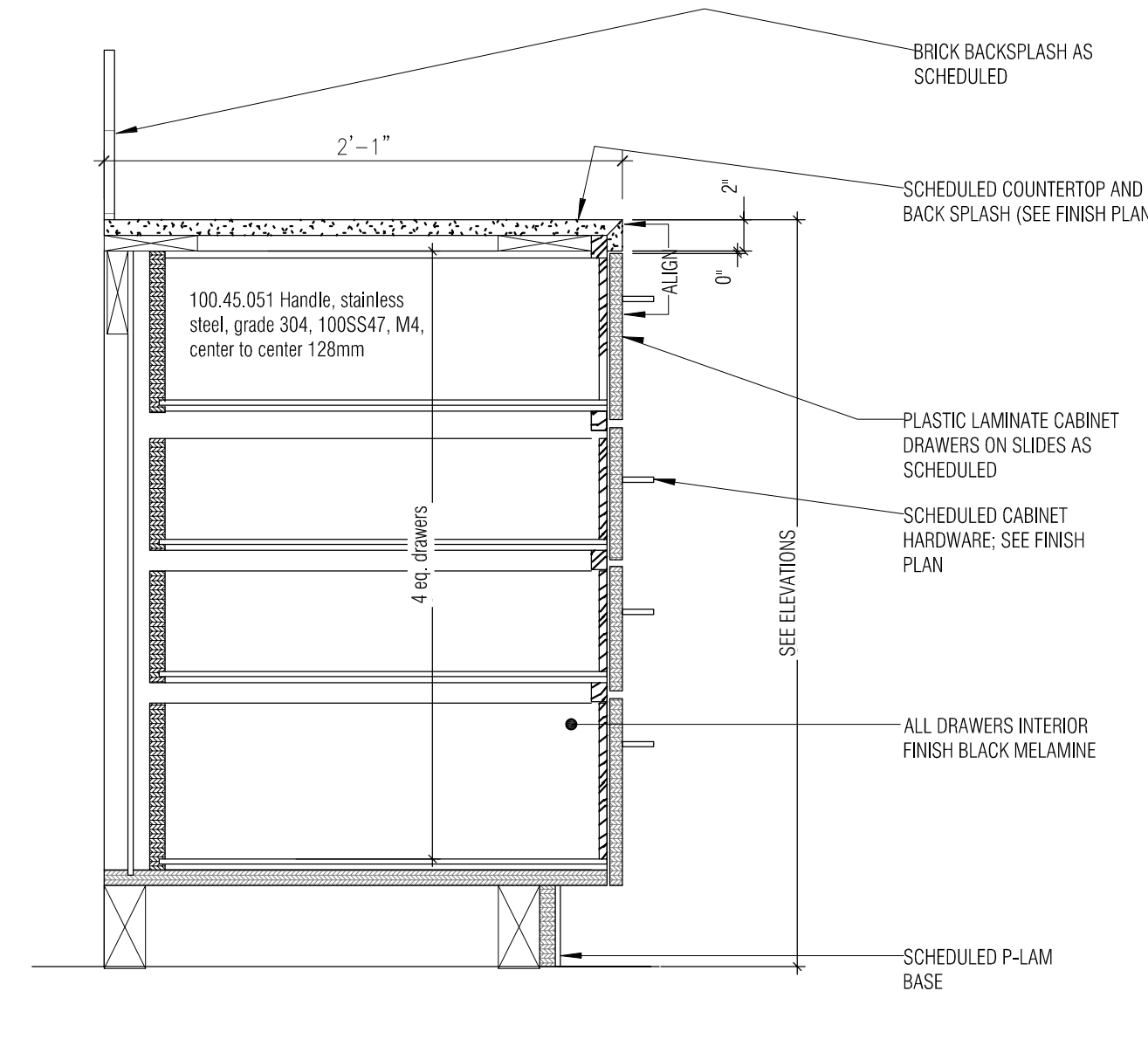

3 BASE CABINET WITH DRAWERS
1 1/2" = 1'-0"

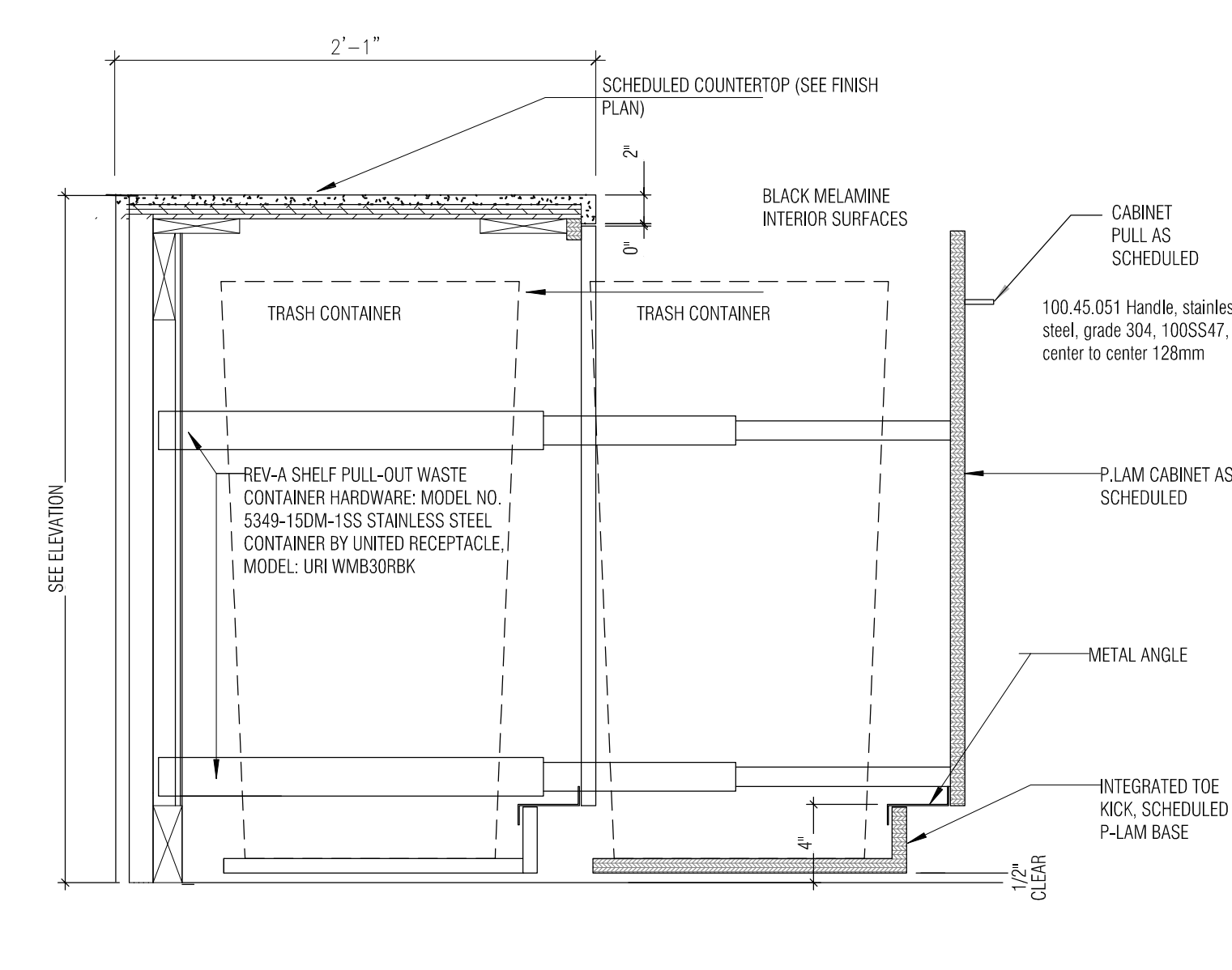

4 UPPER CABINET
1 1/2" = 1'-0"

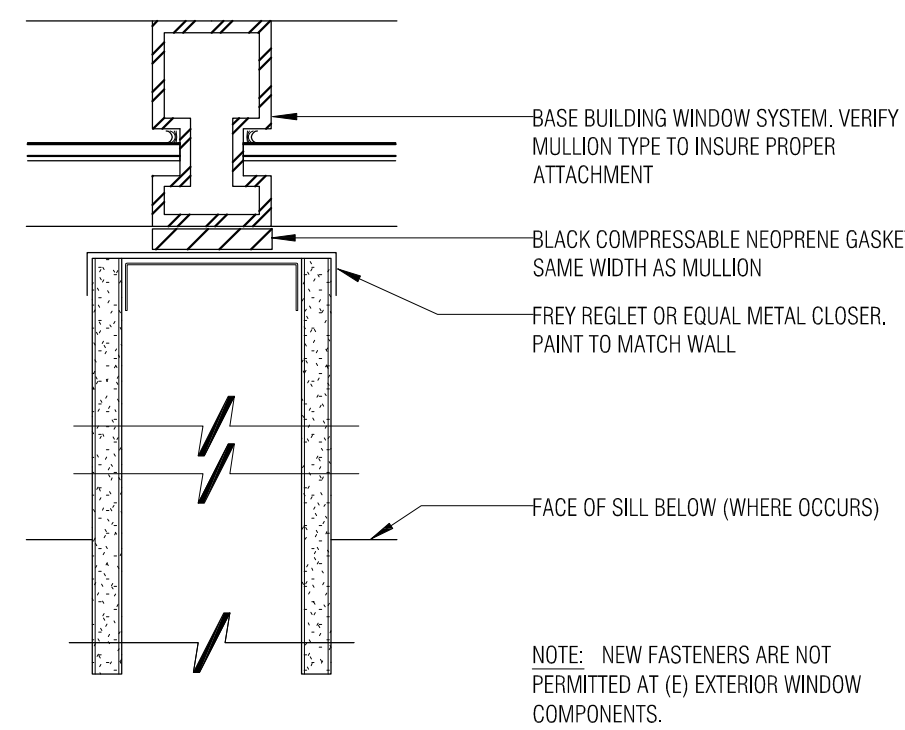

5 PARTITION TO EXTERIOR WINDOW MULLION
3" = 1'-0"

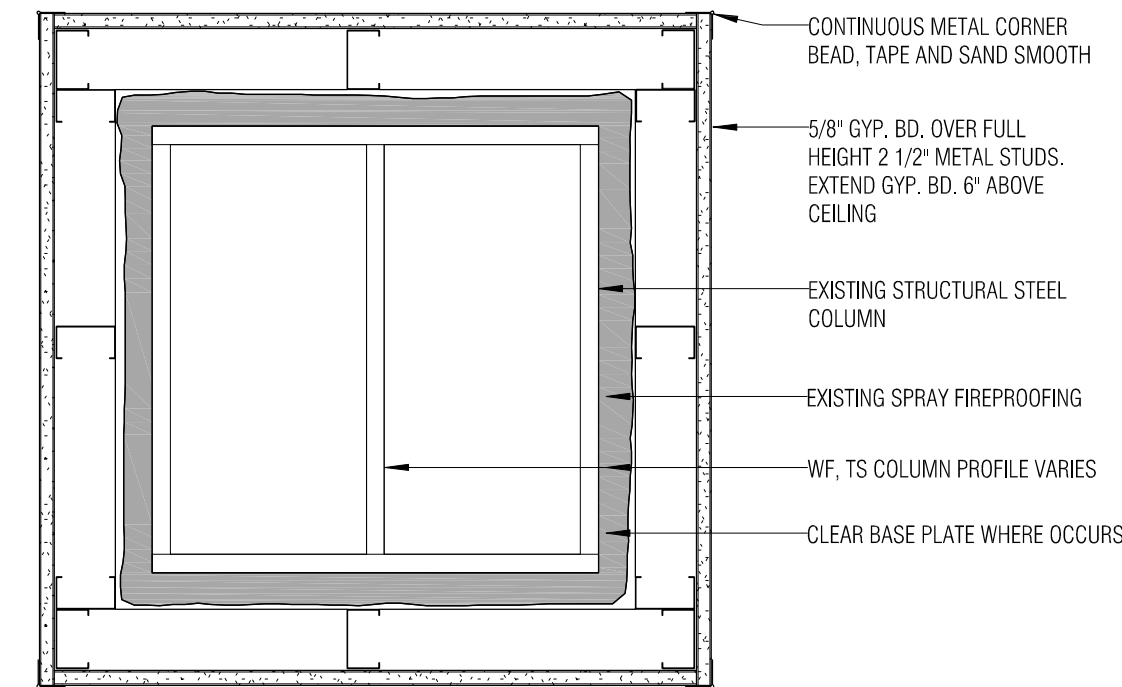

6 TYPICAL COLUMN FURRING
1 1/2" = 1'-0"

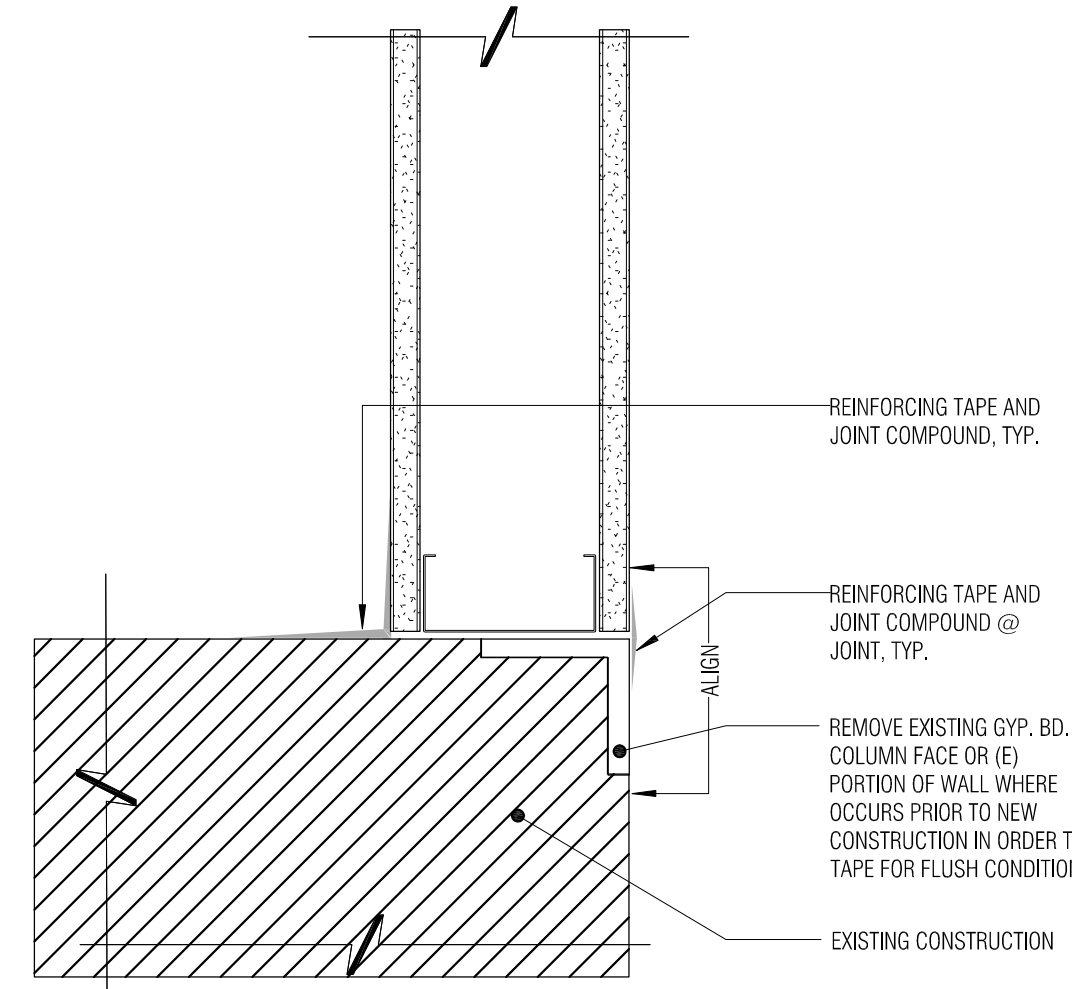

7 PARTITION ALIGN WITH EXISTING STRUCTURE
3" = 1'-0"

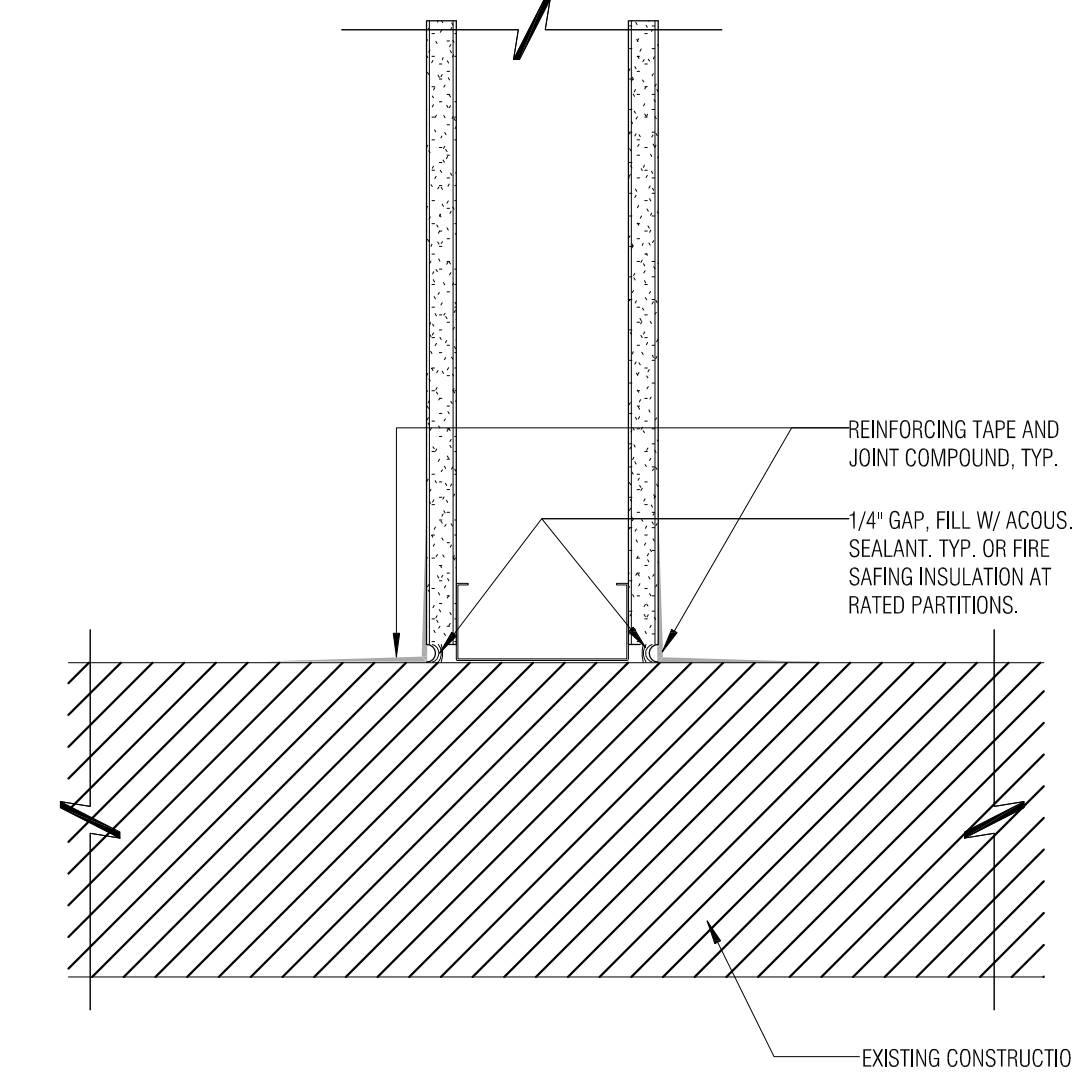

8 PARTITION INTERSECT WITH EXISTING STRUCTURE
3" = 1'-0"

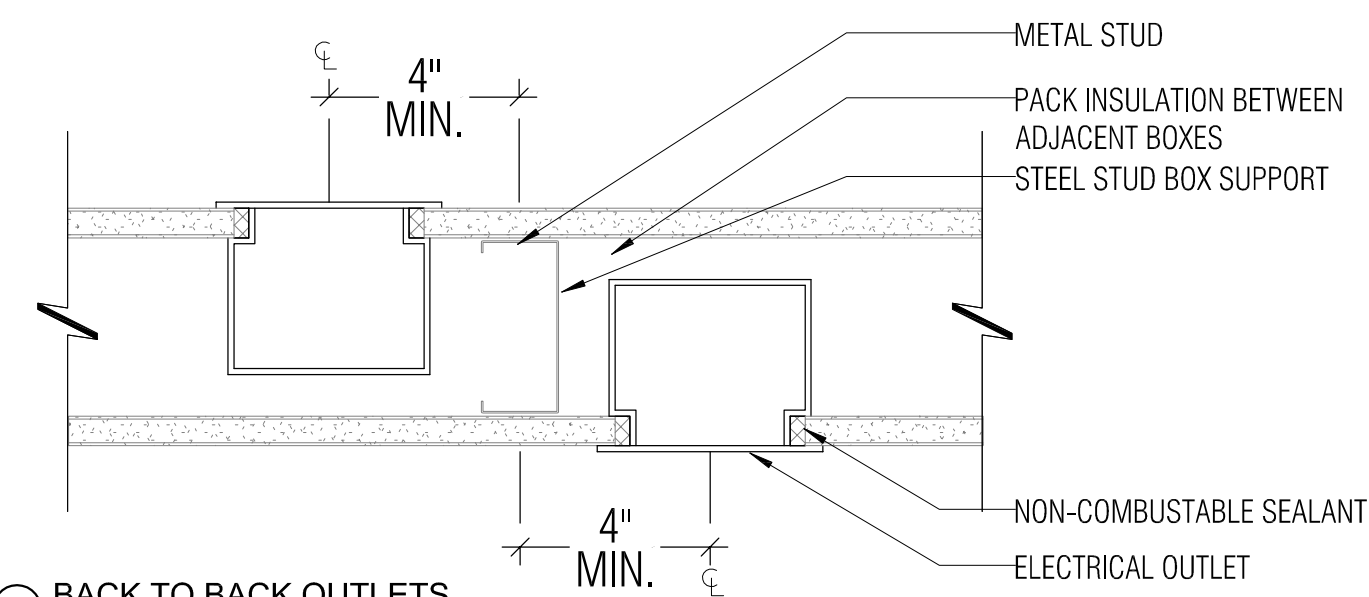

9 BACK TO BACK OUTLETS
3" = 1'-0"

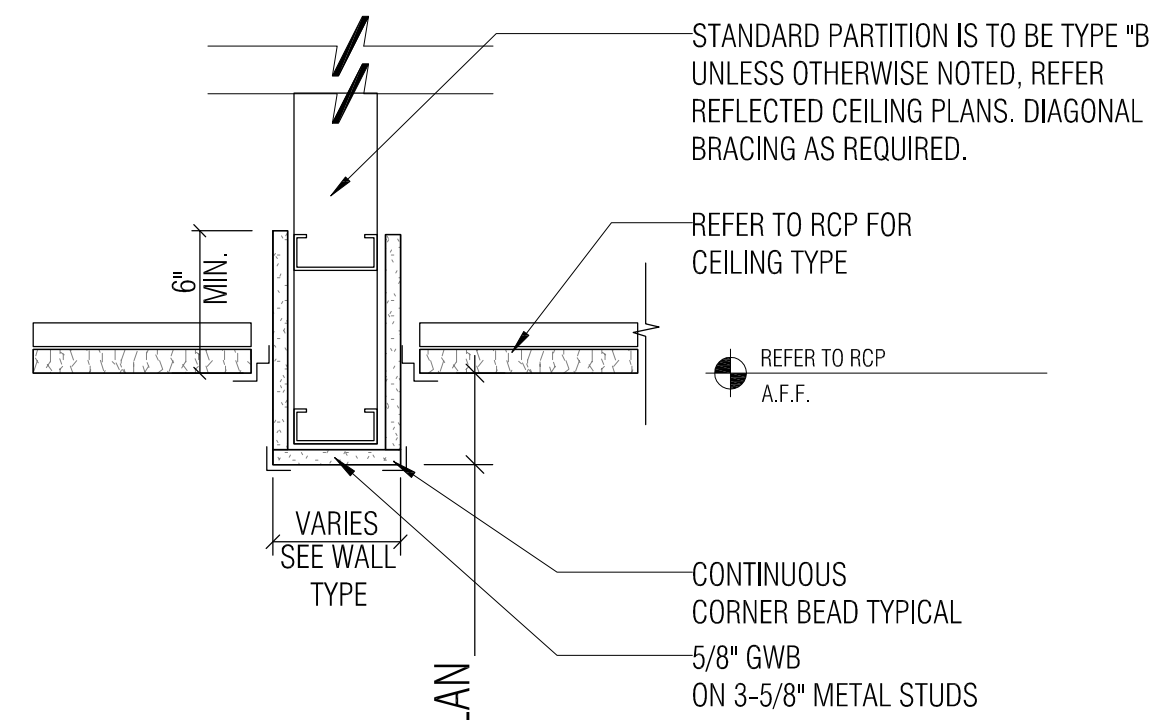

11 TYPICAL SOFFIT DETAIL
1 1/2" = 1'-0"

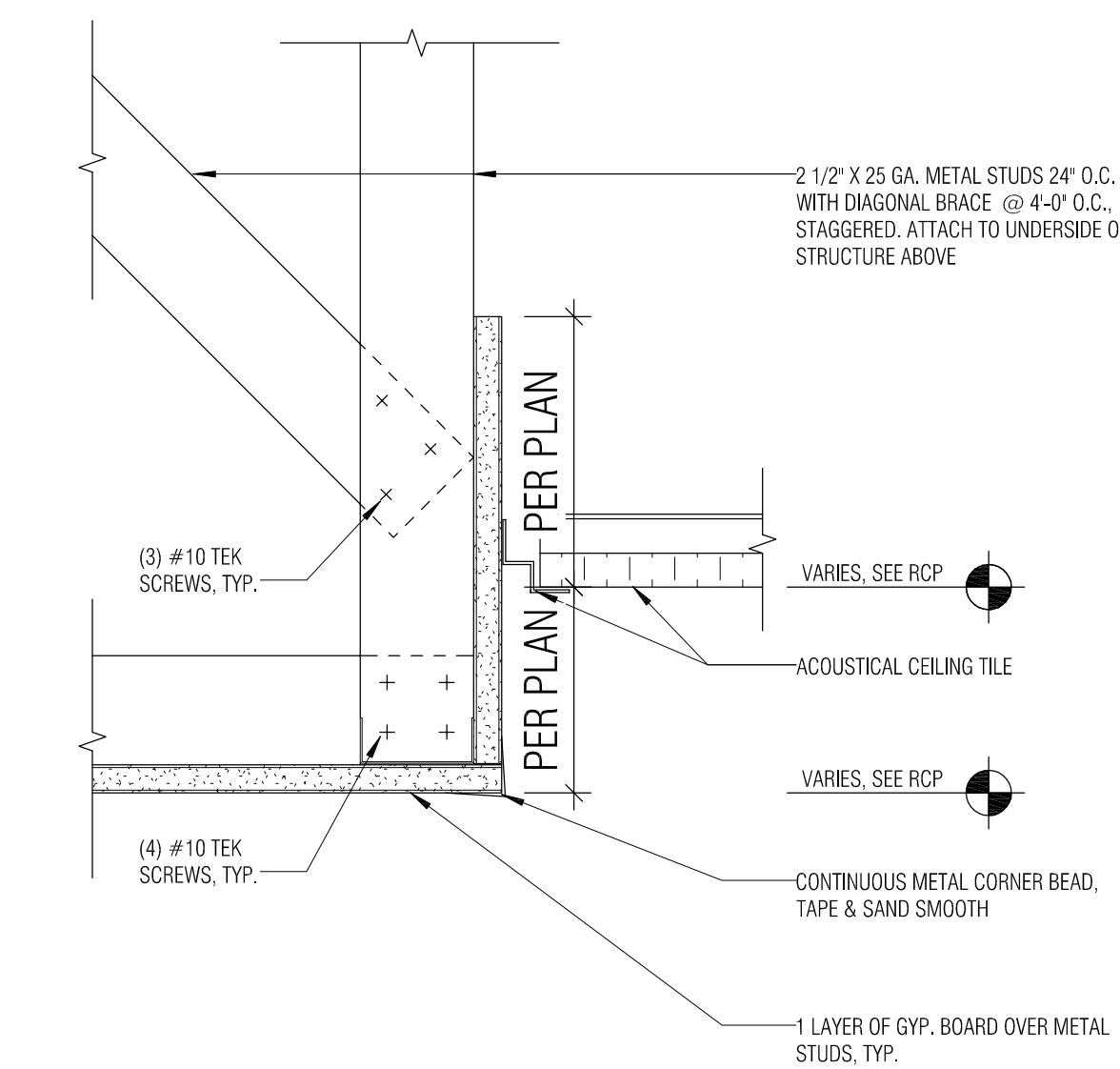

12 GYP. BD. SOFFIT SECTION AT KITCHENETTE
3" = 1'-0"

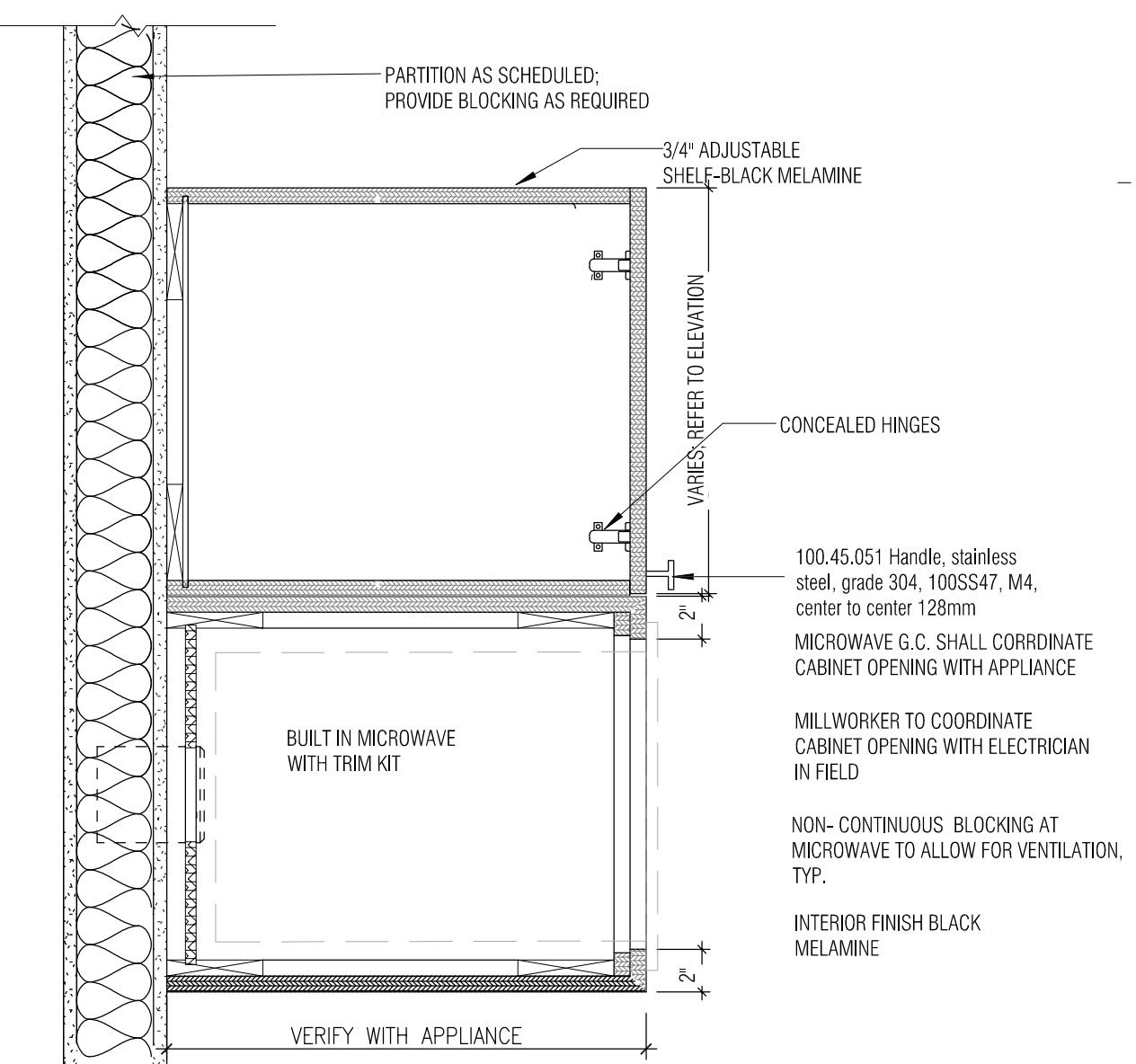

13 UPPER WALL CABINET WITH BUILT IN MICROWAVE
1 1/2" = 1'-0"

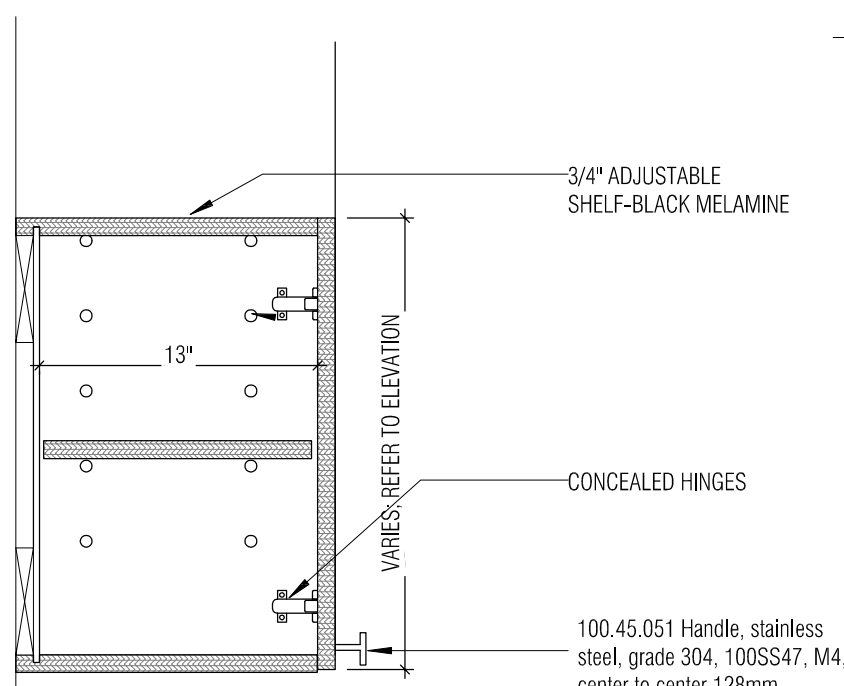

10 UPPER WALL CABINET
1 1/2" = 1'-0"

PROJECT

REVISION NO.

DATE

REVISION NO.

DATE

REVISION NO.

DATE

REVISION NO.

DATE

PENOBSCOT FINANCIAL ADVISORS

1 MONUMENT SQ. FLOOR 5
PORTLAND, ME 04101

DETAILS

DRAWING NO.

A5

SCALE AS NOTED
DATE 01-11-2018
PROJECT NO. 2017.009
DRAWN CHK
DATE