

Dyer Brown & Associates Inc. - ©2017 ALL RIGHTS RESERVED - PLOTTED: Q:\3617\20170237 - BDA Home Loans Collaboration 1\Drawings\50 Portland ME\500 Drawings\50 Fire Protection\50 Fire Protection\0170237 FP-0 FIRE PROTECTION LEGEND, NOTES & ABBREVIATIONS.dwg (Week) June 28, 2017 - 10:27am ead/ah

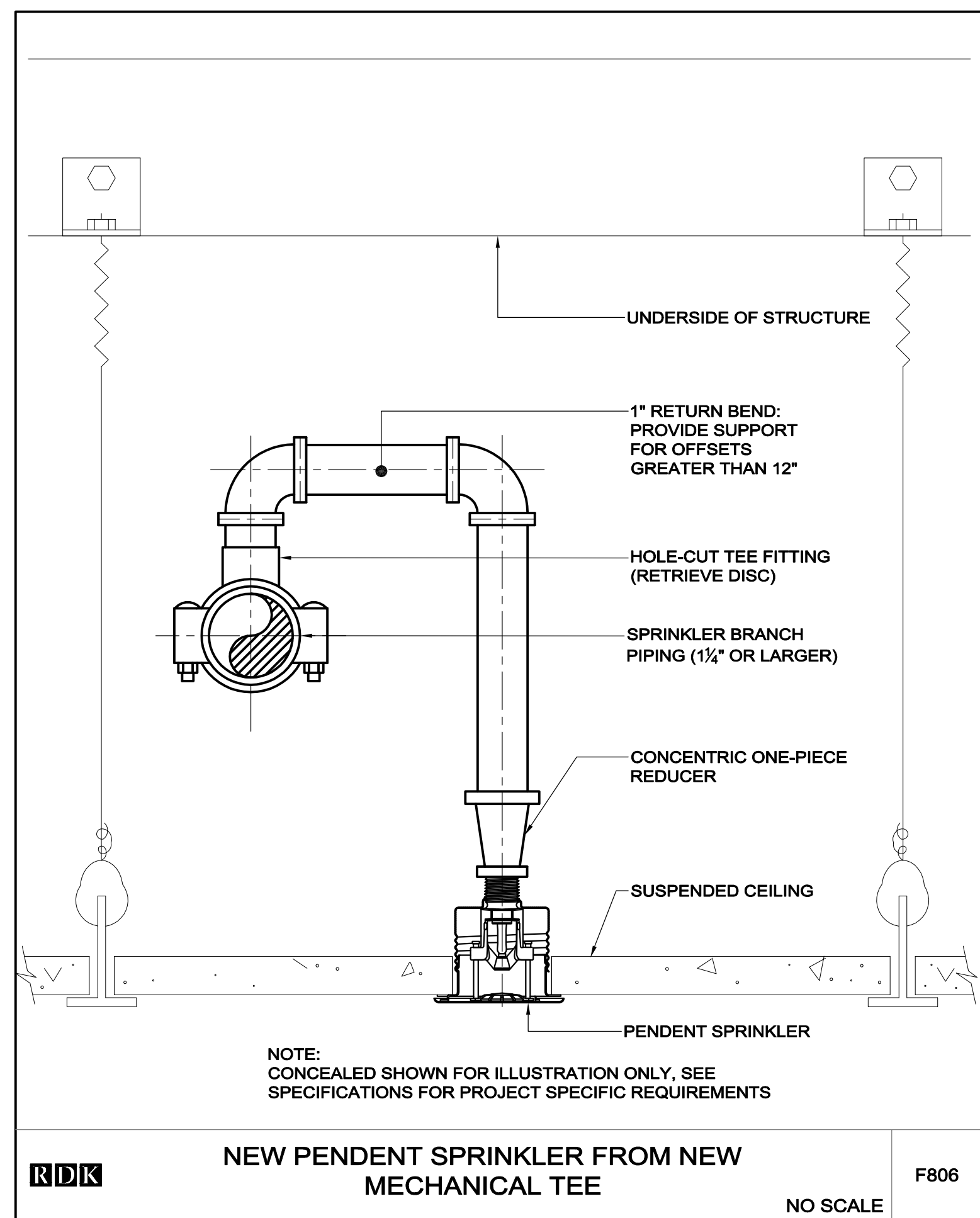
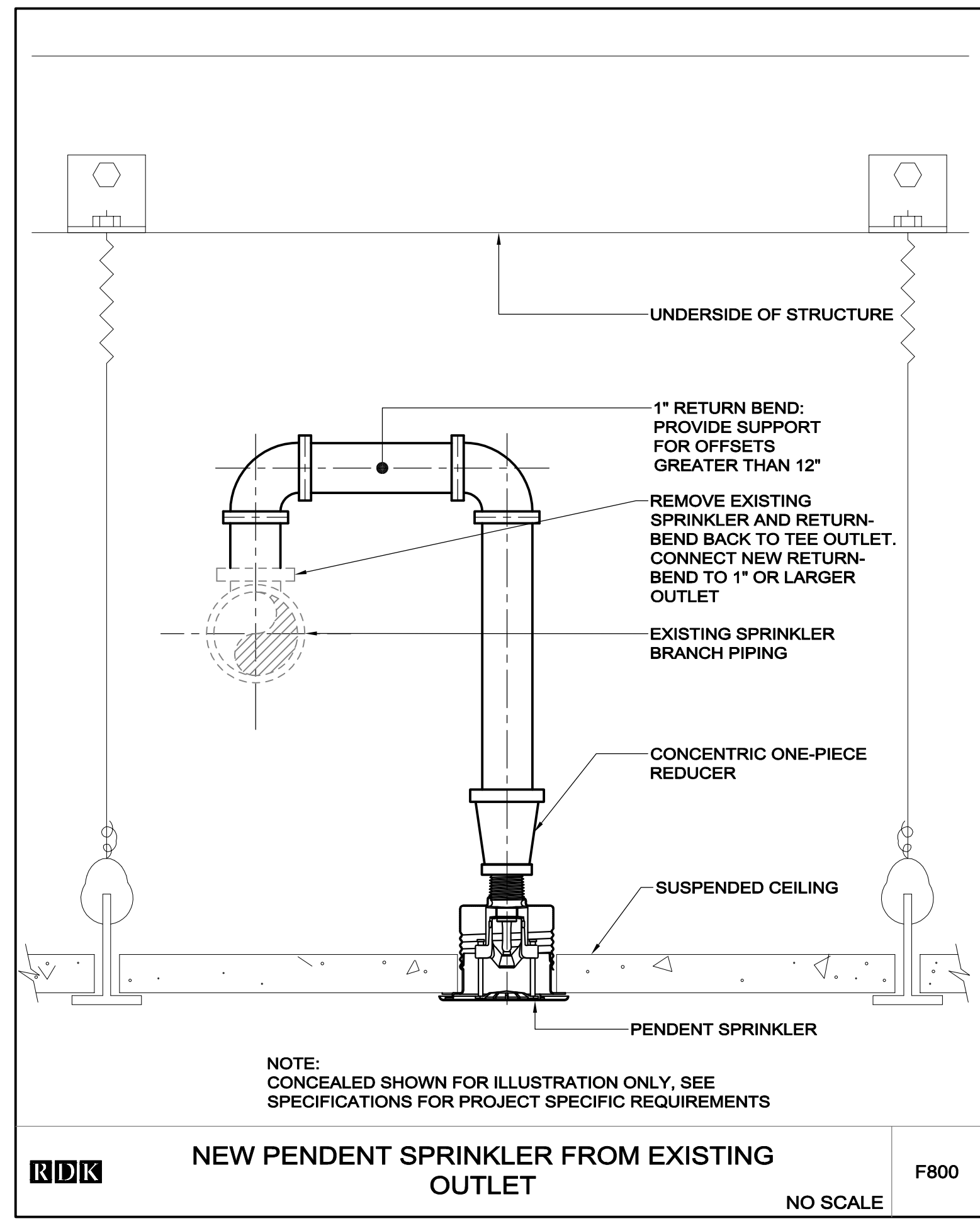

SPRINKLER SCHEDULE							
SYMBOL	CONDITION	RESPONSE	ORIENTATION	COVERAGE	K-FACTOR	FINISH	TEMP RATING
⊗	ETBR	EXISTING	CONCEALED PENDENT/PENDENT	STANDARD	5.6	WHITE/CHROME	ORDINARY
⊙	ETR	EXISTING	CONCEALED PENDENT/PENDENT	STANDARD	5.6	WHITE/CHROME	ORDINARY
●	NEW	QUICK	CONCEALED PENDENT/PENDENT	STANDARD	5.6	WHITE/CHROME	ORDINARY

NOTE:  
\* SPRINKLERS SHALL BE OF THE SAME RESPONSE RATING AS EXISTING TO REMAIN SPRINKLERS WITHIN THE SAME COMPARTMENT. PROVIDE STANDARD RESPONSE SPRINKLERS AS REQUIRED IN ACCORDANCE WITH NFPA 13.

- ### GENERAL NOTES
- FIRE PROTECTION WORK SHALL BE DONE IN ACCORDANCE WITH THE LATEST EDITION OF THE STATE BUILDING CODE, LOCAL AMENDMENTS AND THE REFERENCED NATIONAL FIRE PROTECTION ASSOCIATION CODES INCLUDING 13, 14, 20, AND 24.
  - ALL FIRE PROTECTION SYSTEMS, EQUIPMENT, PIPING AND VALVES SHALL BE INSTALLED AND TESTED BY A SPRINKLER CONTRACTOR LICENSED BY THE STATE AND EXPERIENCED IN THE INSTALLATION OF SPRINKLER SYSTEMS.
  - OBTAIN ALL PERMITS AND PAY ALL FEES ASSOCIATED WITH THIS WORK PRIOR TO COMMENCEMENT.
  - PIPING AND EQUIPMENT IS SHOWN DIAGRAMMATICALLY THE ACTUAL ROUTING OF PIPING AND EXACT LOCATION OF EQUIPMENT SHALL BE DETERMINED IN THE FIELD.
  - THE DRAWINGS SUGGEST ROUTING OF PIPING, PIPE SIZES AND APPROXIMATE LOCATION OF HEADS. THE CONTRACTOR SHALL PRODUCE A COMPLETE SET OF WORKING PLANS IN ACCORDANCE WITH NFPA 13. THE SYSTEM SHALL BE HYDRAULICALLY CALCULATED PER THE DESIGN CRITERIA SPECIFIED. ALL PLANS AND CALCULATIONS SHALL BE STAMPED BY THE CONTRACTOR'S REGISTERED FIRE PROTECTION ENGINEER AND SHALL BE SUBMITTED TO THE LOCAL AUTHORITY AND OWNER'S UNDERWRITER FOR APPROVAL.
  - IN ADDITION TO REVIEWING AND COORDINATING WITH THE OTHER TRADES (CIVIL, STRUCTURAL, ARCHITECTURAL, HVAC AND ELECTRICAL) THE CONTRACTOR SHALL VISIT THE SITE AND FAMILIARIZE HIMSELF WITH THE DETAILS OF CONSTRUCTION.
  - FURNISH AND INSTALL ALL NECESSARY PIPING EQUIPMENT SUPPORTS AND ANY EQUIPMENT NOT SHOWN ON DRAWINGS OR CALLED FOR IN THE SPECIFICATIONS BUT NECESSARY TO PROVIDE A COMPLETE AND WORKABLE SYSTEM.
  - PROVIDE ACCESS TO ALL EQUIPMENT REQUIRING PERIODIC SERVICE AND MAINTENANCE.
  - FURNISH ACCESS PANELS TO THE GENERAL CONTRACTOR FOR INSTALLATION UNDER THE RELATED TRADES.
  - PITCH ALL PIPING TO DRAIN, PROVIDE AN AUXILIARY DRAIN AT ALL LOW POINTS.
  - PROVIDE WATER TIGHT SLEEVES ON ALL PIPES PASSING THROUGH EXTERIOR WALLS AND BASEMENT FLOORS.
  - ALL VALVES CONTROLLING FIRE PROTECTION MAINS SHALL BE PROVIDED WITH TAMPER/SUPERVISORY SWITCHES WIRED TO THE FIRE ALARM CONTROL PANEL.
  - CONTRACTOR SHALL PROVIDE FIRE STOPPING FOR ALL PENETRATIONS THRU FIRE WALLS AND FIRE RATED SEPARATIONS. CONTRACTOR SHALL COORDINATE WITH THE ARCHITECTURAL DRAWINGS FOR LOCATIONS AND RATINGS OF ALL FIRE RATED SEPARATIONS AND BARRIERS. INSTALLATION OF FIRE STOPPING SHALL BE IN ACCORDANCE WITH MANUFACTURERS RECOMMENDATIONS.
  - ALL FIRE PROTECTION SYSTEMS SHALL BE SEISMICALLY BRACED ACCORDING TO THE APPLICABLE SECTIONS OF THE STATE BUILDING CODE AND THE REFERENCED EDITION OF NFPA-13.
  - INSTALL SPRINKLERS IN ACCORDANCE WITH ALL NFPA 13 OBSTRUCTION CRITERIA. PROVIDE ADDITIONAL SPRINKLERS OR ALTERNATE LOCATIONS (WITH ENGINEER'S APPROVAL) TO COMPLY WITH ALL SPACING AND OBSTRUCTION CRITERIA.
  - PROVIDE MINIMUM 1" PIPE TO ALL INDIVIDUAL SPRINKLERS. DO NOT RE-USE EXISTING 1/2" AND 3/4" OUTLETS FOR NEW ARM-OVER OR RETURN BEND INSTALLATION. PROVIDE NEW 1" (MINIMUM) CONNECTION TO EXISTING BRANCHLINE AS NECESSARY.

- ### DEMOLITION NOTES
- DEMOLITION NOTES:**
- REFER TO THE ARCHITECTURAL DRAWINGS FOR THE EXTENT OF THE DEMOLITION SCOPE OF WORK AND AREA. THE DEMOLITION PLANS INDICATE THE GENERAL INTENT AND ARE NOT INTENDED TO SHOW ALL ITEMS TO BE REMOVED OR RETAINED.
  - VISIT THE SITE PRIOR TO SUBMISSION OF THE BIDS TO BECOME FAMILIAR WITH THE ACTUAL CONDITIONS AND EXTENT OF THE WORK.
  - TRACE AND LABEL ALL EXISTING SYSTEMS WITHIN THE DEMOLITION AREA AND BEYOND PRIOR TO DISCONNECTION AND REMOVAL TO ENSURE THAT NO AREA OUTSIDE THE DEMOLITION AREA IS AFFECTED. REVIEW IN DETAIL WITH THE GENERAL CONTRACTOR AND OWNER WHAT IS TO BE REMOVED AND REMAIN PRIOR TO WORK COMMENCING THE DEMOLITION. THERE SHALL BE NO INTERRUPTION OF SERVICES OUTSIDE THE DEMOLITION AREA WITHOUT APPROVAL FROM THE OWNER'S REPRESENTATIVE.
  - NOTIFY THE OWNER'S REPRESENTATIVE IMMEDIATELY OF ANY UNANTICIPATED HIDDEN CONDITIONS ENCOUNTERED DURING THE DEMOLITION.
  - ALL ITEMS REMOVED SHALL BE OFFERED TO THE OWNER FOR SALVAGE. IF THE OWNER DOES NOT TAKE POSSESSION, DISPOSE OF THE ITEMS IN A SAFE AND LEGAL MANNER. ALL ITEMS CLASSIFIED AS HAZARDOUS SHALL BE DISPOSED AS HAZARDOUS WASTES AND A UNIFORM HAZARDOUS WASTE MANIFEST SHALL BE PROVIDED TO THE OWNER.
  - NOTIFY UTILITY COMPANIES IN ACCORDANCE WITH THEIR REQUIREMENTS PRIOR TO DEMOLITION. VERIFY THAT THE UTILITIES HAVE BEEN DISCONNECTED, VALVED, CAPPED AND MADE SAFE PRIOR TO DEMOLITION.
  - ENSURE THE SAFE PASSAGE OF PERSONS IN AND AROUND THE BUILDING DURING DEMOLITION. PREVENT INJURY TO PERSONS AND DAMAGE TO PROPERTY. PROVIDE ADEQUATE SHORING AND BRACING TO PREVENT COLLAPSE. IMMEDIATELY REPAIR DAMAGED PROPERTY TO THE CONDITION BEFORE BEING DAMAGED. TAKE EFFECTIVE MEASURES TO PREVENT WINDBLOWN DUST.
  - DO NOT USE CUTTING TORCHES UNTIL WORK AREA IS CLEARED OF FLAMMABLE MATERIALS. AT CONCEALED SPACES, SUCH AS PIPE INTERIORS, VERIFY CONDITION AND CONTENTS OF HIDDEN SPACE BEFORE STARTING FLAME-CUTTING OPERATIONS. MAINTAIN FIRE WATCH AND PORTABLE FIRE-SUPPRESSION DEVICES DURING FLAME-CUTTING OPERATIONS. MAINTAIN ADEQUATE VENTILATION WHEN USING CUTTING TORCHES.
  - THE EXISTING FIRE PROTECTION SYSTEM SHALL REMAIN FULLY FUNCTIONAL DURING THE ENTIRE DEMOLITION AND CONSTRUCTION PERIOD. ALL REQUIRED SYSTEM SHUTDOWNS SHALL BE COORDINATED WITH AND APPROVED BY THE OWNER'S REPRESENTATIVE AND THE AUTHORITY HAVING JURISDICTION.
  - CREATE AND SUBMIT IMPAIRMENT PLANS TO THE AHJ IF ANY PORTION OF THE EXISTING FIRE PROTECTION SYSTEM IS TAKEN OUT OF SERVICE DURING THE EXECUTION OF THE PROJECT. COORDINATE IMPAIRMENT PLANS WITH THE OWNER.
  - REMOVE ABANDONED AND/OR SCHEDULED TO BE DEMOLISHED FIRE PROTECTION SPRINKLERS, PIPE, FITTINGS, HANGERS, AND SUPPORTS BACK TO THE LAST ACTIVE MAIN OR BRANCHLINE. CAP OR PLUG ALL OPEN OR UNUSED OUTLETS.

### ABBREVIATIONS

ACT	ACoustICAL TILE
AFF	ABOVE FINISH FLOOR
AHJ	AUTHORITY HAVING JURISDICTION
AP	ACCESS PANEL
BLDG	BUILDING
CLG	CEILING
CTE	CONNECT TO EXISTING
CONT	CONTINUATION
DIA	DIAMETER
DN	DOWN
DWG	DRAWING
EAB	ELECTRIC ALARM BELL
EL/ELEV	ELEVATION
ETBR	EXISTING TO BE REMOVED
ETR	EXISTING TO REMAIN
EX	EXISTING
F	FIRE SERVICE/MAIN/BUILDING WET PIPING
FDV	FIRE DEPARTMENT VALVE
FFE	FINISH FLOOR ELEVATION
FLR	FLOOR
FP	FIRE PROTECTION
FS	FLOW SWITCH
GC	GENERAL CONTRACTOR
GPM	GALLONS PER MINUTE
INV	INVERT
LPS	LOW PRESSURE SWITCH
MECH	MECHANICAL
NC	NORMALLY CLOSED
NO	NORMALLY OPEN
NTS	NOT TO SCALE
NIC	NOT IN CONTRACT
PRV	PRESSURE REDUCING/REGULATING VALVE
PS	PRESSURE SWITCH
PSI	POUNDS PER SQUARE INCH
SPEC	SPECIFICATION
SPD	SPRINKLER DRAIN
SPR	WET SPRINKLER SYSTEM
STP	STANDPIPE SYSTEM
TS	TAMPER SWITCH
TYP	TYPICAL
WACV	WET ALARM CHECK VALVE
ZCA	ZONE CONTROL ASSEMBLY

### PIPING LINETYPES

—SPR—	WET PIPE SPRINKLER SYSTEM
----	EXISTING TO REMAIN
+++++	EXISTING TO BE REMOVED

### EQUIPMENT & VALVES

FDV	FIRE DEPARTMENT HOSE VALVE
ZCA	SPRINKLER ZONE CONTROL ASSEMBLY

### ANNOTATIONS

1	DETAIL DESIGNATION NUMBER
FP-1	DETAIL DESIGNATION DRAWING

### PIPING SYMBOLS

↗	DIRECTION OF SLOPE
⊙	ELBOW UP OR RISE
⊘	ELBOW DOWN OR DROP
⊖	TEE LOOKING DOWN
⊕	TEE LOOKING UP
→	FLOW IN DIRECTION OF ARROW
⊔	CAP OR END OF PIPE
⊗	CONNECT TO EXISTING
	UNION



Dyer Brown Architects One Winthrop Square  
dyerbrown.com Boston, MA 02110-1209

T 617 426 1680  
F 617 426 2187



### REVISIONS

### BANK OF AMERICA - HOME LOANS

BANK OF AMERICA  
1 MONUMENT SQUARE, PORTLAND ME

### TITLE FIRE PROTECTION LEGEND, NOTES & ABBREVIATIONS

DATE: 06/29/17 JOB NO.: 20170237

DRAWING NO.: FP-0

ISSUED FOR CONSTRUCTION