

- ### GENERAL NOTES
1. THE HEIGHT OF WATER CLOSETS SHALL BE 17" TO 19" MEASURED TO THE TOP OF THE TOILET SEAT.
  2. THE FLUSH CONTROL OF THE WATER CLOSET TANK MUST BE MOUNTED ON THE WIDE SIDE OF THE ROOM.
  3. LAVATORIES SHALL BE MOUNTED WITH RIM OR COUNTER SURFACE NO HIGHER THAN 34 IN. ABOVE THE FINISH FLOOR. PROVIDE A CLEARANCE OF AT LEAST 25 IN. ABOVE THE FINISH FLOOR TO THE BOTTOM OF THE APRON.
  4. EXPOSED HOT WATER AND DRAIN PIPES UNDER LAVATORIES SHALL BE INSULATED WITH A BOOT OR SLEEVE MANUFACTURED FOR THIS PURPOSE.
  5. MIRRORS SHALL BE MOUNTED WITH THE BOTTOM EDGE OF THE REFLECTING SURFACE NO HIGHER THAN 40 IN. ABOVE THE FINISH FLOOR AND THE TOP/MOST EDGE OF THE MIRROR SHALL BE AT LEAST 7'4" ABOVE THE FINISH FLOOR.
  6. WHERE MEDICINE CABINETS ARE PROVIDED, AT LEAST ONE SHALL BE LOCATED WITH A USABLE SHELF NO HIGHER THAN 44 IN. ABOVE THE FLOOR.
  7. HANDRAILS AND GRAB BARS NOMINAL DIAMETER OR WIDTH OR THE GRIPPING SURFACES SHALL BE 1-1/4" TO 1-1/2". THE SPACE BETWEEN THE WALL AND THE GRAB BAR SHALL BE 1-1/2". GRAB BARS SHALL NOT ROTATE WITHIN THEIR FITTINGS. INSTALL FIRE-TREATED WOOD BLOCKING IN WALLS AT NEW GRAB BAR LOCATIONS.
  8. ALL GRAB BARS AND LAVATORIES SHALL BE ABLE TO WITHSTAND 250 LBF.

- ### ENLARGED RESTROOM PLAN NOTES
1. SEE SHEET A120 FOR FINISH SCHEDULE AND TYPICAL WALL FINISH DETAIL.
  2. SEE SHEET A110 FOR WALL DIMENSIONS. USE MOISTURE RESISTANT GYPSUM BOARD AT WALLS BEHIND PLUMBING FIXTURES.
  3. PROVIDE BATT INSULATION IN WALLS WHERE SCHEDULED ON SHEET A110.
  4. ADD MATCHING BOBRICK 1 8" VERTICAL BAR WHERE REQUIRED.
  5. SINKS, TOILETS, AND URINAL ARE TO BE REPLACE WITH NEW FIXTURES; AT THE EXISTING LOCATIONS.
  6. DOOR/WINDOW TAG - SEE SCHEDULE SHEET A500
  7. FINISH TAG - SEE FINISH SCHEDULE ON SHEET A120

### FIXTURE & ACCESSORY SCHEDULE

KEY	DESCRIPTION	MANUFACTURER	MODEL	COLOR	SUPPLIED	INSTALLED CONNECTION	REMARKS
					GC LL GC	LL GC MFG. KEC	
A	WALL MOUNTED SOAP DISPENSER	BOBRICK	B-2111	STAINLESS STEEL	●	●	DISPENSER - 48" A.F.F. MAX.
B	COAT HOOK	BOBRICK	B-212	STAINLESS STEEL	●	●	BACK OF REST ROOM DOOR, HOOK - 15" TO 48" A.F.F.
C	PAPER TOWEL	GEORGIA-PACIFIC	ENMOTION 59462	TRANSLUCENT SMOKE	●	●	DISPENSER - 15" - 48" A.F.F.
D	MIRROR	BOBRICK	B-293	STAINLESS STEEL	●	●	40" MAX TO BOTTOM OF REFLECTIVE SURFACE
E	BABY CHANGING TABLE	BOBRICK KONA BEAR KARE	VERTICAL KB101-00	CREAM	●	●	SHELF @ 34" A.F.F.
F	TOILET TISSUE DISPENSER	GEORGIA-PACIFIC	COMPACT 56784	TRANSLUCENT SMOKE	●	●	OUTLET - 15" A.F.F., CENTERLINE 7'-9" FROM FRONT OF WATER CLOSET
G	42" HORIZONTAL GRAB BAR	BOBRICK	B-6806.99	STAINLESS STEEL	●	●	(1) 2X6'S 4'-0" LONG CENTER MOUNTED @ 33" A.F.F. TO CENTER OF SUPPORT GRAB BAR.
G.1	18" VERTICAL GRAB BAR	BOBRICK	B-6806.99	STAINLESS STEEL	●	●	2X6 WOOD BLOCKING FOR 18" VERTICAL GRAB BAR
G.1	36" HORIZONTAL GRAB BAR	BOBRICK	B-6806.99	STAINLESS STEEL	●	●	(1) 2X6'S 4'-0" LONG CENTER MOUNTED @ 33" A.F.F. TO CENTER OF SUPPORT GRAB BAR.
H	SANITARY NAPKIN DISPENSER	SOUTHERN STAINLESS	FG-016	STAINLESS STEEL	●	●	
I	WATER CLOSET	ZURN	25665.214.00.00.00	WHITE	●	●	SEAT - 25955 58-EL, SEAT - 17" TO 19" A.F.F.
J	ALT 1-WATER CLOSET (TANK)	AMERICAN STANDARD	CADET 3 FLOWISE, KT HEIGHT ELONGATED (2835.128)	WHITE	●	●	SEAT - 5321.110-EL, SEAT - 17" TO 19" A.F.F.
K	LAVATORY	ZURN	25344	WHITE	●	●	WALL MOUNTED, FAUCET - Z6915-F (CHROME PLATED), RIM 34" MAX A.F.F.
L	URINAL	ZURN	25750	WHITE	●	●	FLUSH VALVE - Z6003AV-ENS, RIM 17" A.F.F.
M	URINAL SCREEN (NOT USED)	BRADLEY	MODEL #2 WALL HUNG WITH WING BRACKET	STAINLESS STEEL			INSTALL PER MFR RECOMMENDATIONS 42" X 18" SCREEN
N	TOILET PARTITION	BRADLEY	SENTINEL OVERHEAD BRACED SERIES 400	STAINLESS STEEL	●	●	CONTR TO COORDINATE REQ'D SIZES INSTALL PER MFR RECOMMENDATIONS

NOTE: ALL FIXTURES & ACCESSORIES MUST MEET ALL NATIONAL AND LOCAL CODES AND ADA REQUIREMENTS. PROVIDE SOLID BLOCKING AT ALL WALL MOUNTED FIXTURES FOR SECURE ANCHORING. VERIFY LOCATION WITH MANUFACTURERS SPECIFICATIONS. CLEAR SILICONE CAULK ALL FIXTURES TO PARTITION.

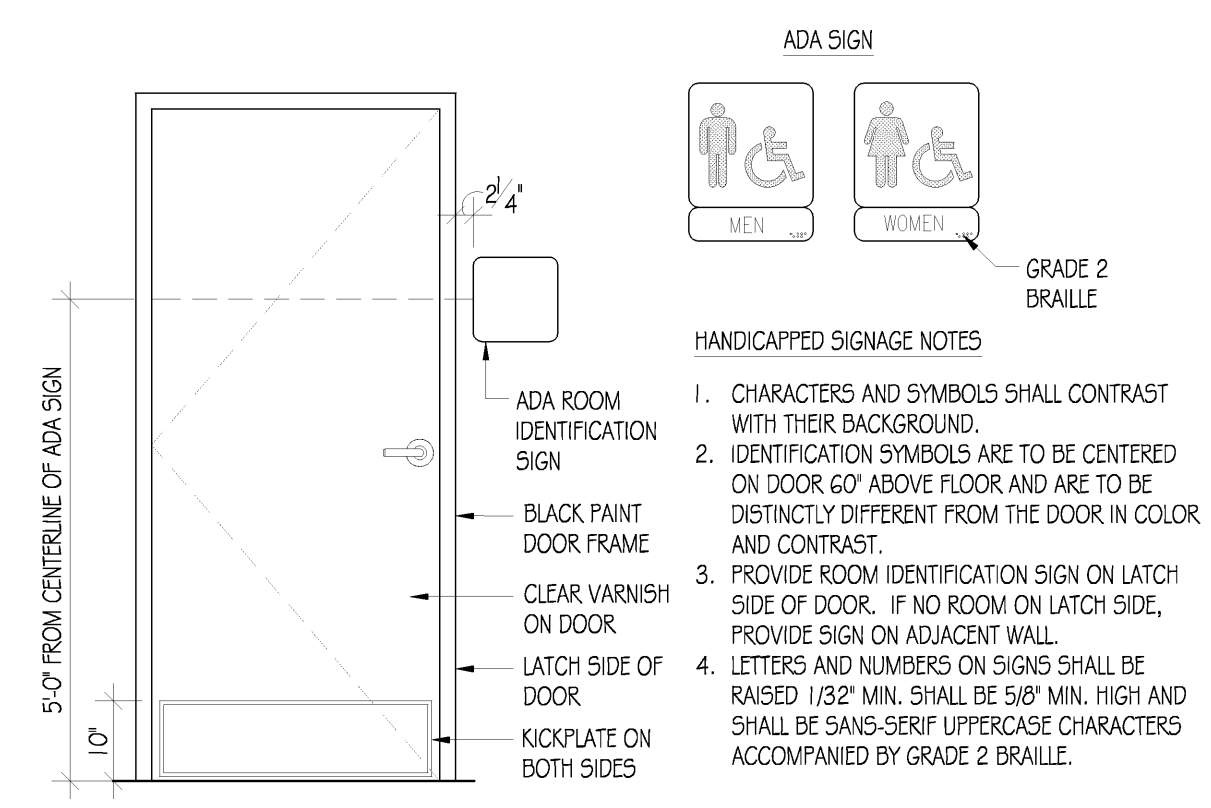

C1 ENLARGED RESTROOM PLAN

C2 ACCESSIBLE RESTROOM SIGNAGE DETAIL

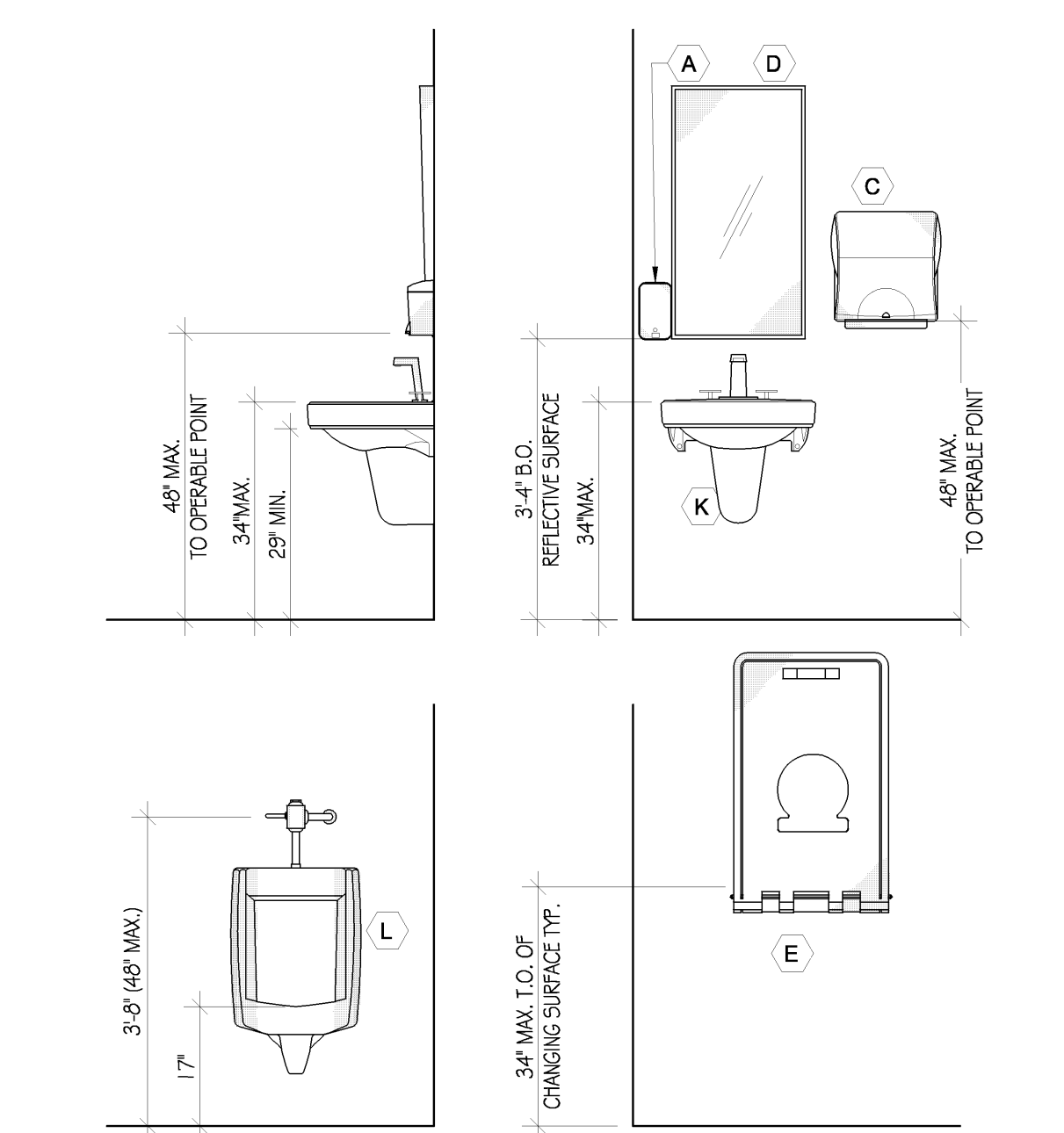
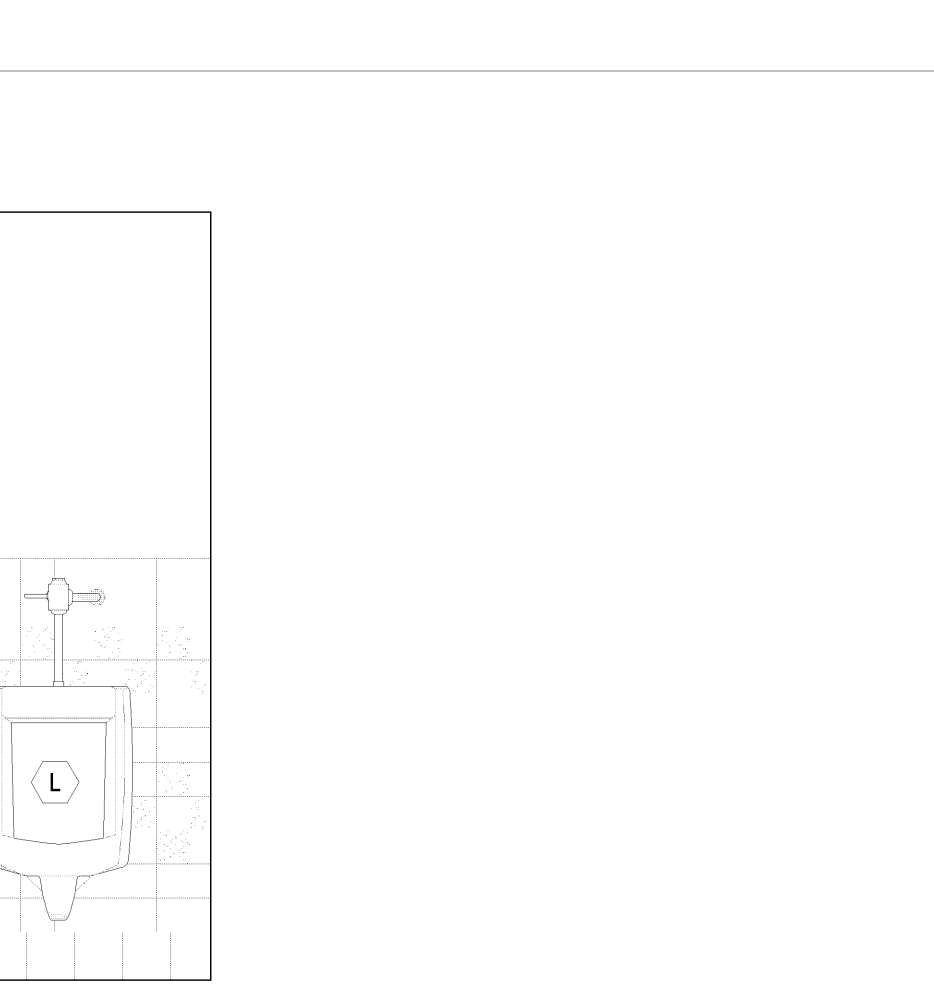
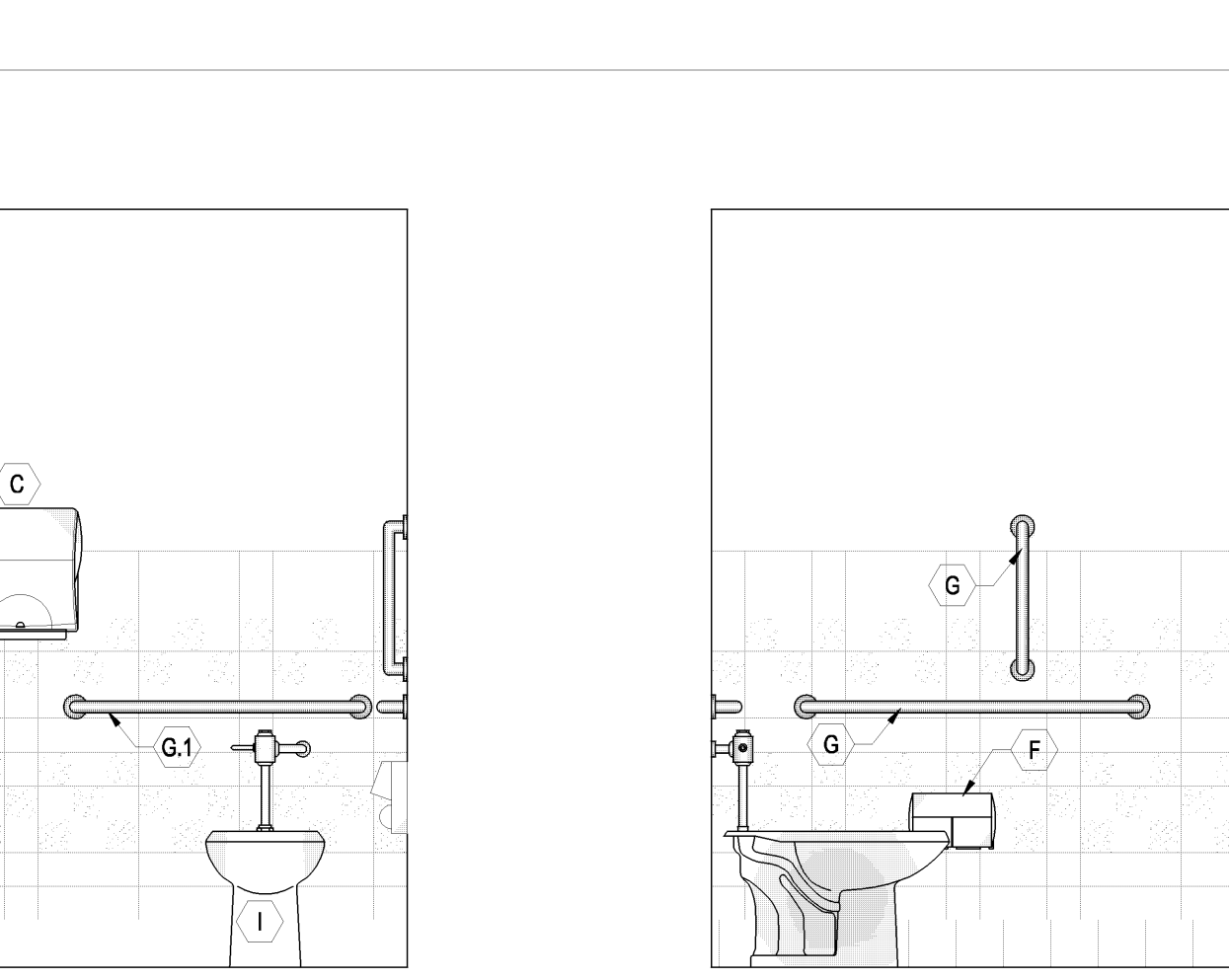
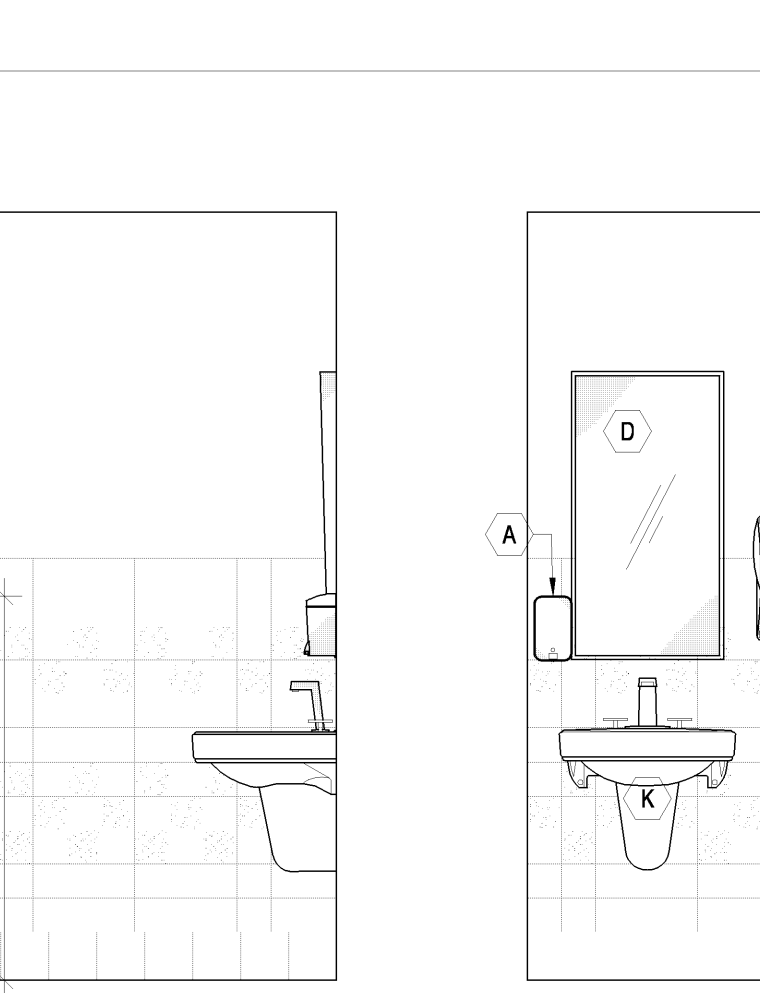
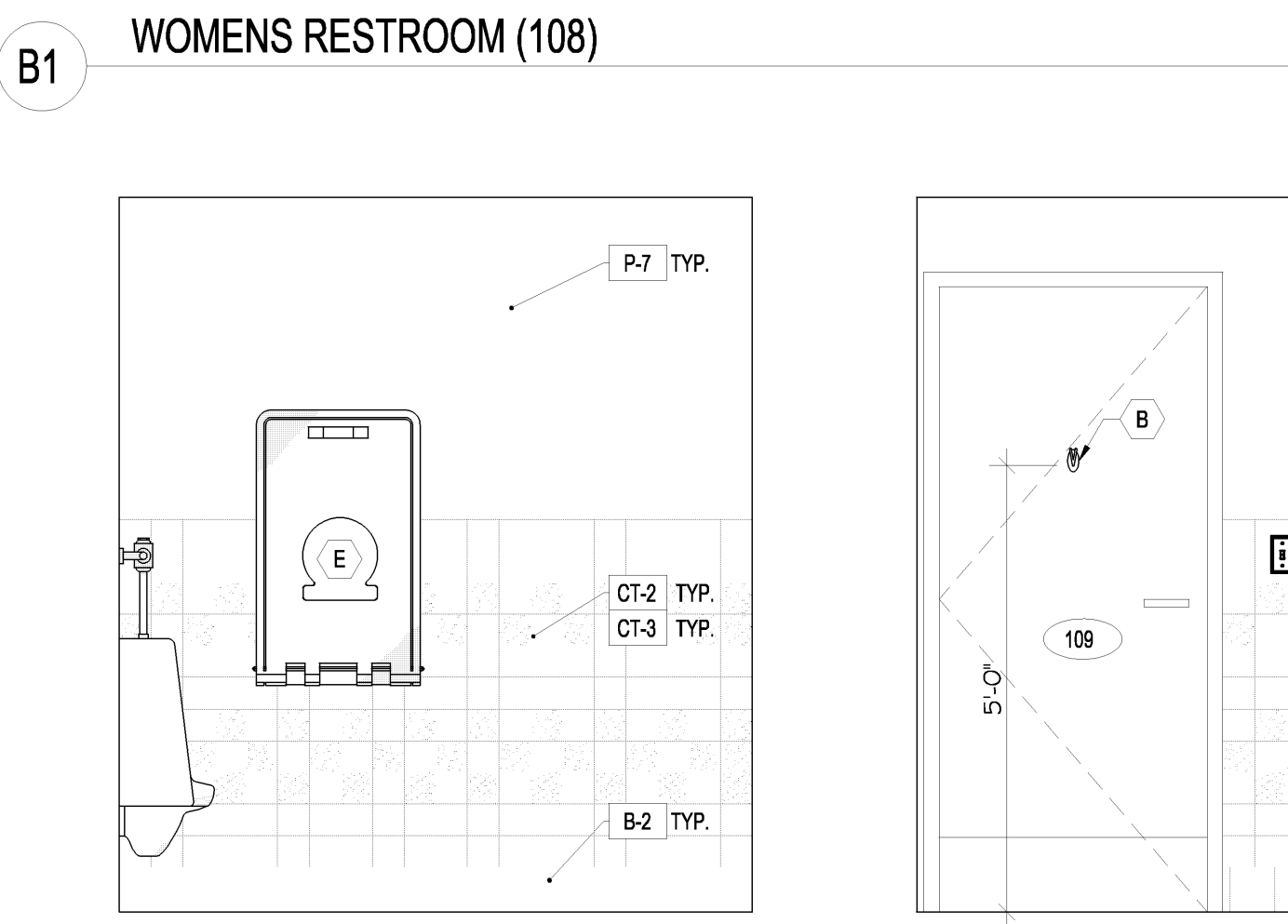
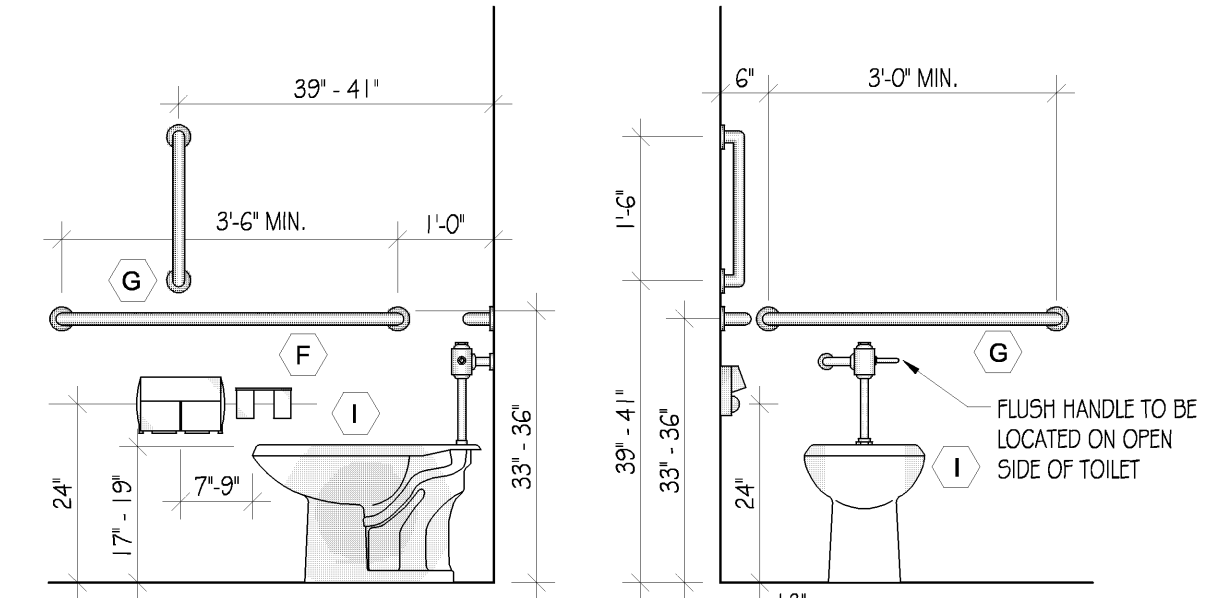
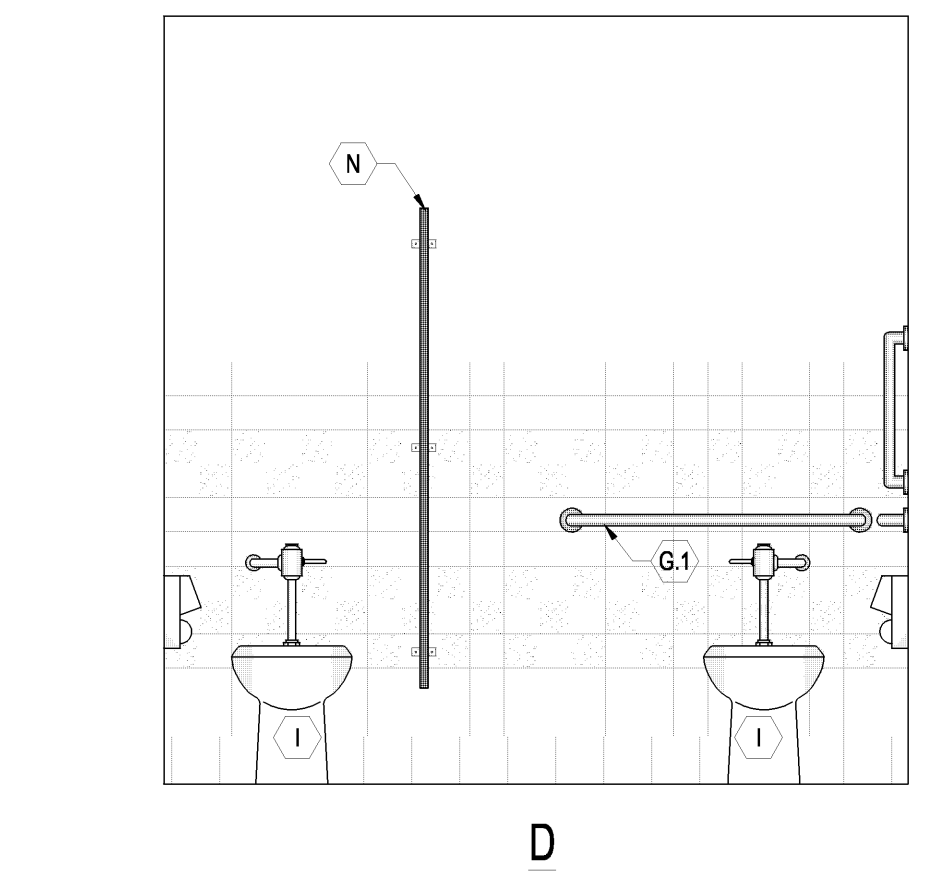
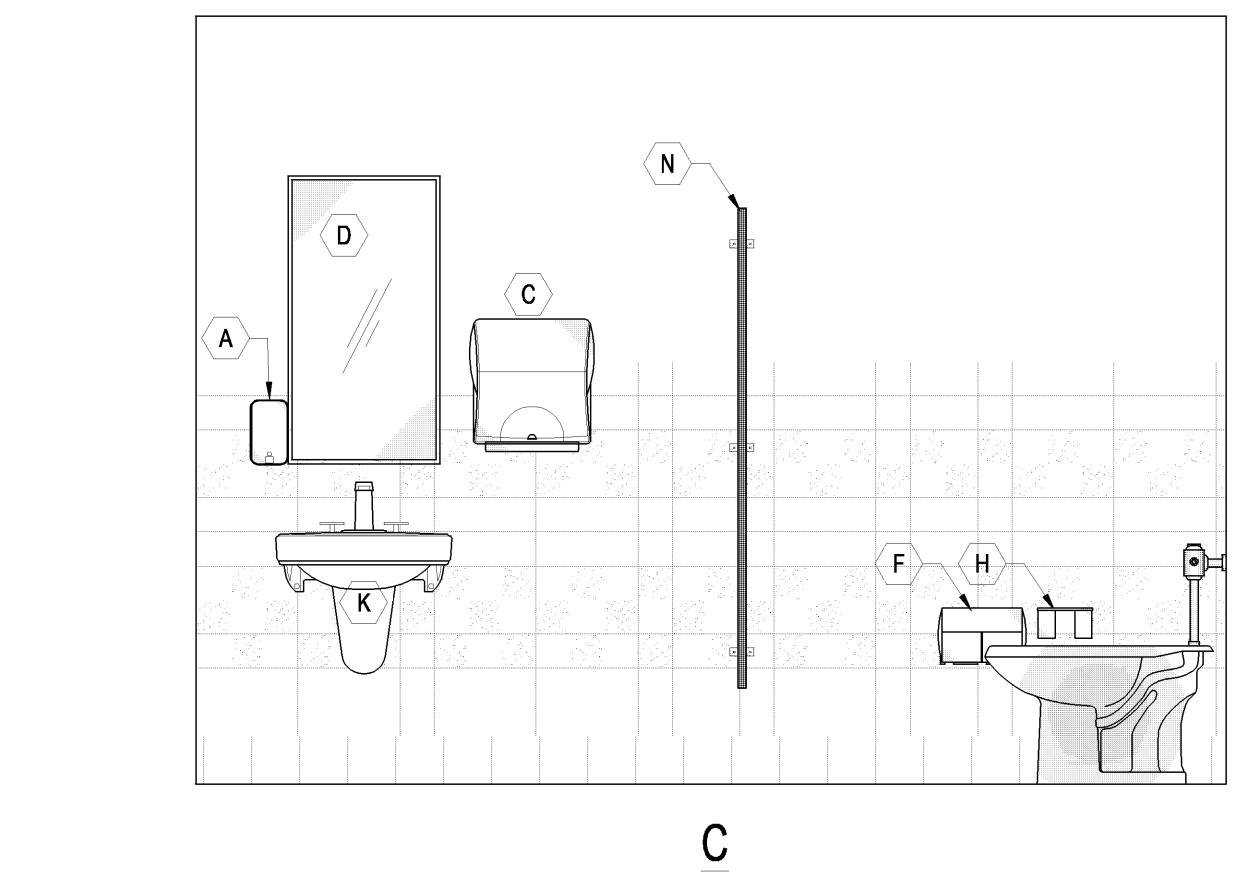
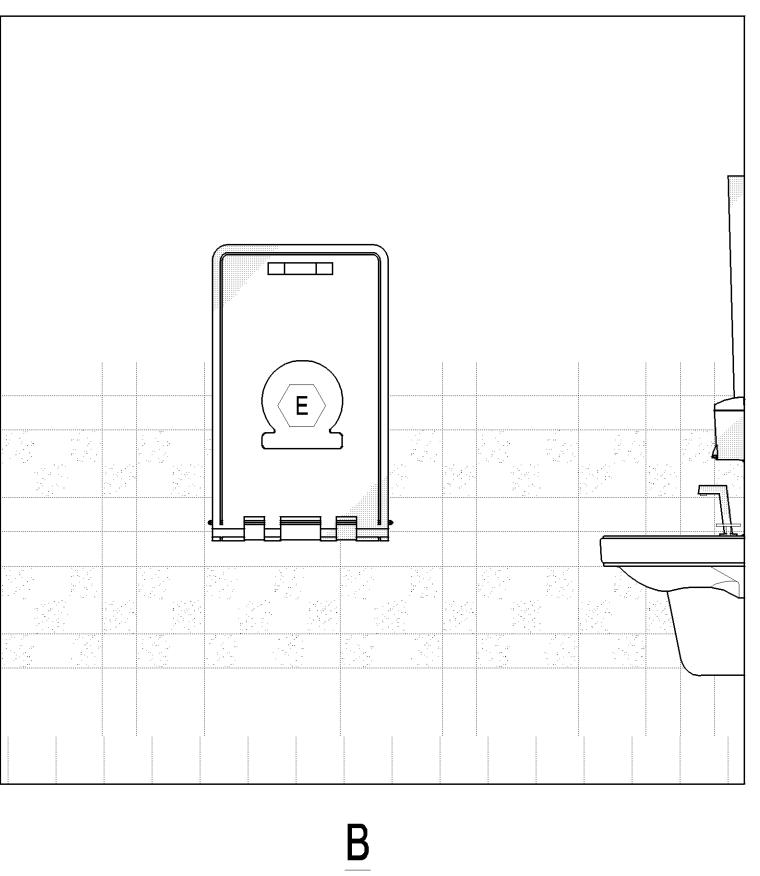
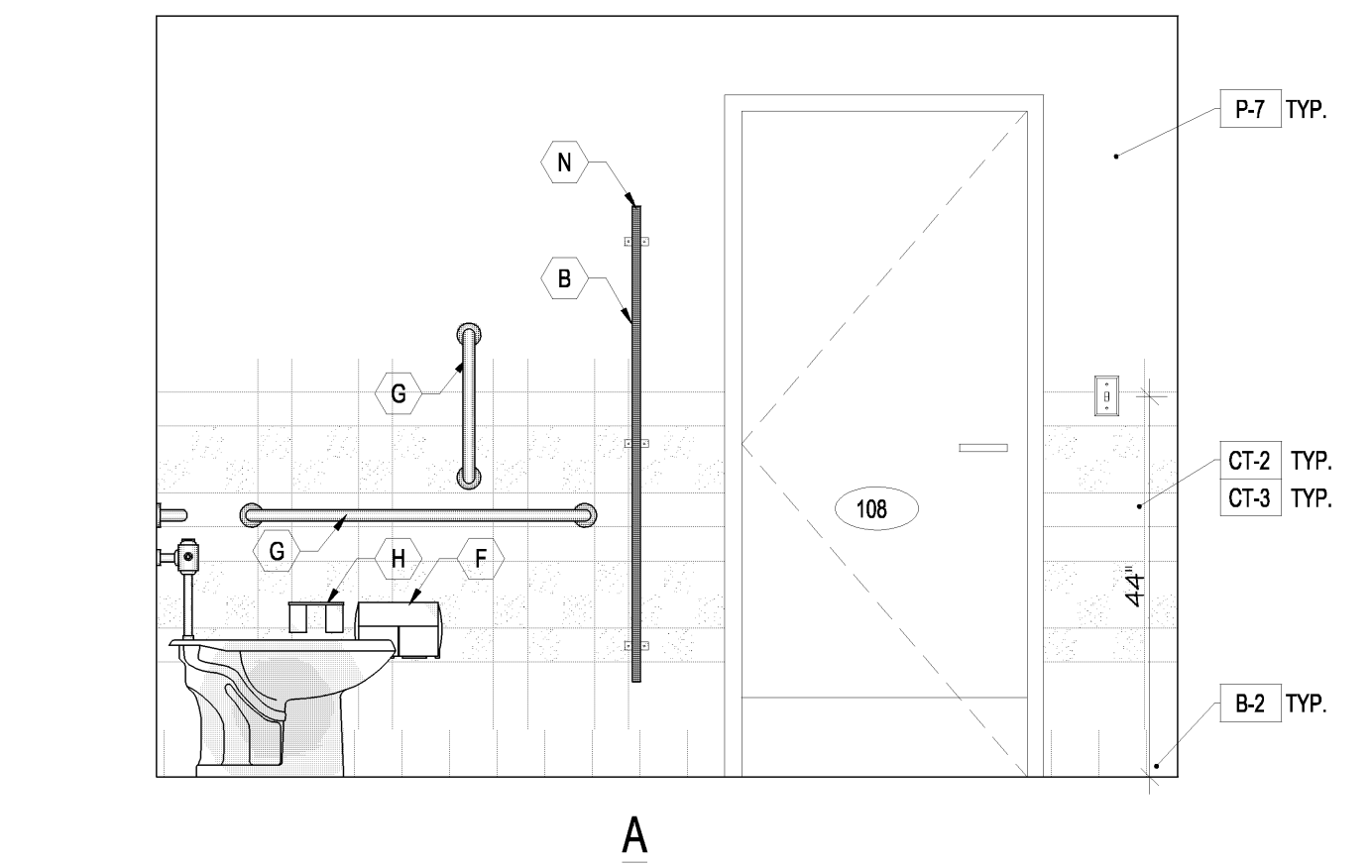

A1 MENS RESTROOM (109)

A4 REQUIRED ACCESSIBLE FIXTURE CLEARANCES

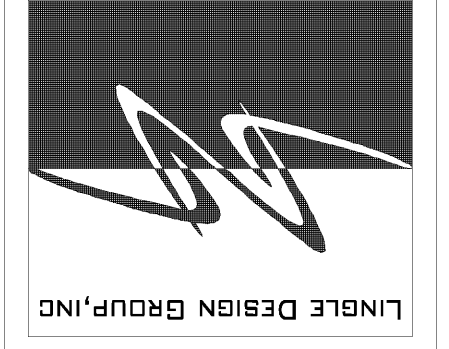

© ALL DRAWINGS AND WRITTEN MATERIAL CONTAINED HEREIN ARE THE PROPERTY OF THE LINGLEDISIGN GROUP, INC. THEY MAY NOT BE REPRODUCED, COPIED, REUSED, OR DISCLOSED IN ANY MANNER WITHOUT WRITTEN AUTHORIZATION FROM THE ARCHITECT.

REVISIONS:	DATE:	DESCRIPTION:
#	12/15/2010	ISSUED FOR PERMIT
PROJECT NUMBER:	10-1033	
DRAWN BY:	SRM	
CHECKED BY:	BVE	

SHEET TITLE:  
**ENLARGED RESTROOM PLAN**

SHEET NUMBER:  
**A400**